

No. 762,664.

PATENTED JUNE 14, 1904.

C. W. SPONSEL.
HYDROCARBON BURNER.

APPLICATION FILED OCT. 30, 1902. RENEWED NOV. 21, 1903.

NO MODEL.

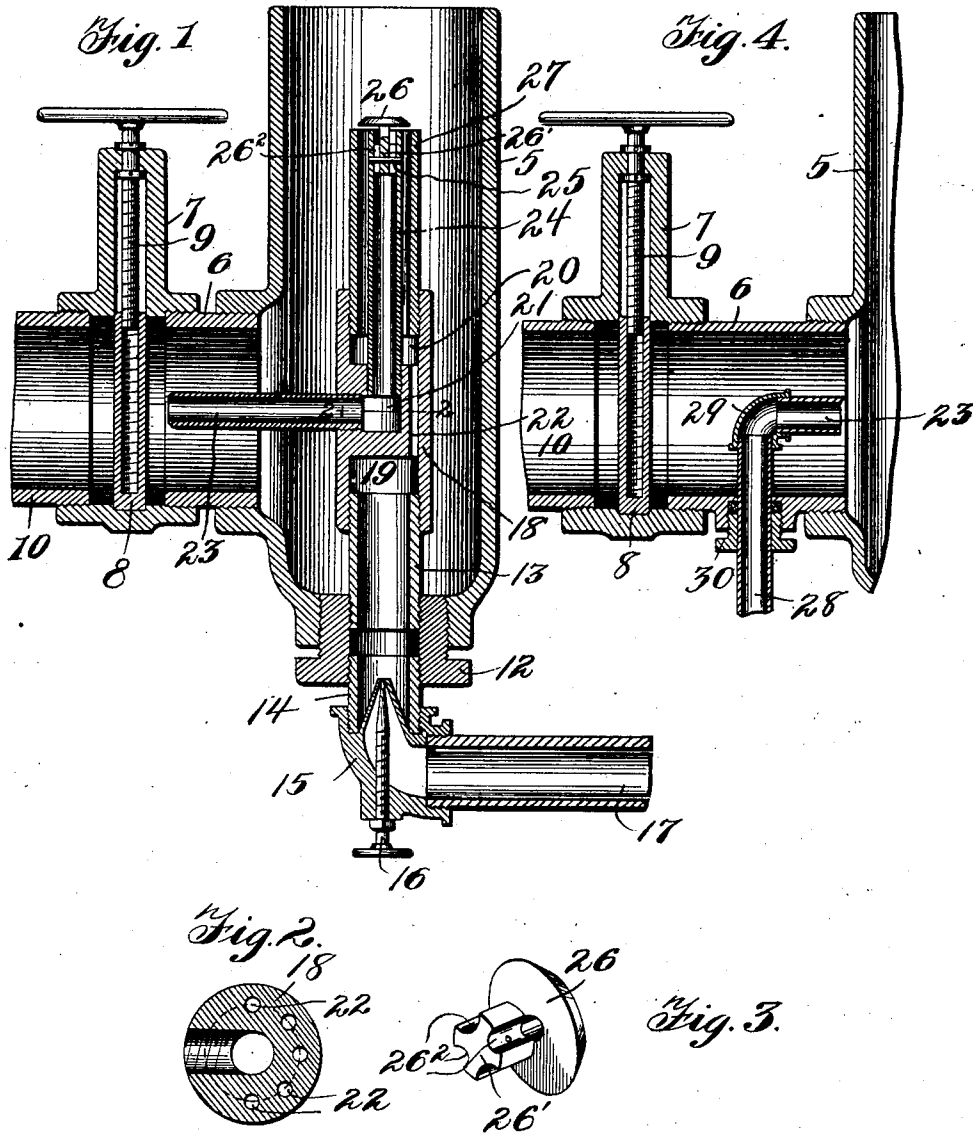

Witnesses:

G. G. Campbell.

Francis E. Blodgett.

Inventor:

Charles W. Sponsel.

By His Attorneys:

Blodgett & Peck

UNITED STATES PATENT OFFICE.

CHARLES W. SPONSEL, OF HARTFORD, CONNECTICUT.

HYDROCARBON-BURNER.

SPECIFICATION forming part of Letters Patent No. 762,664, dated June 14, 1904.

Application filed October 30, 1902. Renewed November 21, 1903. Serial No. 182,198. (No model.)

To all whom it may concern:

Be it known that I, CHARLES W. SPONSEL, a citizen of the United States, residing at Hartford, in the county of Hartford and State of Connecticut, have invented certain new and useful Improvements in Hydrocarbon-Burners, of which the following is a specification.

My invention relates to hydrocarbon-burners; and it has for its object the provision of an improved burner of this character by means of which thorough combustion takes place and intense heat is generated.

A further object of the invention is the provision of a device of the character mentioned in which air or steam at the desired pressure may be supplied to the burner, the air entering a casing surrounding the burner and a part thereof being admitted, preferably at about the center of the air-conduit, to the interior of said burner.

A further object of the invention is the provision of a burner of peculiar construction located approximately at the center of a surrounding casing or chamber, as will be hereinafter described.

Other objects of the invention will be set forth in the detailed construction, which now follows.

In the accompanying drawings, Figure 1 is a longitudinal vertical section of my improved burner. Fig. 2 is a transverse section of one of the fittings of the burner, taken on line 2 2 of Fig. 1. Fig. 3 is a perspective view of the spreader; and Fig. 4 is a partial section, similar to Fig. 1, showing a modified construction.

Like numerals designate similar parts throughout the several views.

Referring to the drawings, the numeral 5 designates a casing in which is threaded a nipple 6, and to this nipple is connected a valve-chamber 7, in which may be fitted a gate or other valve 8, capable of adjustment by means of a screw 9. An air-supply-pipe 10 is connected to this valve-chamber, and through it air at the pressure desired is introduced to the same.

Threaded into one end of the casing 5 is a

gland 12, in which is fitted a nipple 13, and also projecting from said gland is a nipple 14 for the reception of a fitting 15, containing what is shown as a needle-valve 16, although other suitable valves may be substituted therefor, if desired. Communicating with this fitting or valve-chamber 15 is a conduit 17, through which oil under pressure is supplied to the burner, the quantity of said oil admitted to the burner being regulated by the valve 16 in an obvious manner.

Secured to and projecting from the nipple 13 is a fitting 18 of peculiar construction, said fitting being provided with chambers 19 and 20, respectively, in its ends, with a central chamber 21 and with a series of passages 22, connecting said chambers 19 and 20. Inserted in said fitting 18 and communicating with the central chamber 21 is an air-pipe 23, which is shown located contrally of the nipple 6, and hence in a place for receiving air at its greatest pressure as it is supplied thereto from the pipe 10 or otherwise.

Communicating with the chamber 21 at right angles to the pipe 23 is a conduit 24, and in the opposite end of this conduit is secured by a pin 25 or otherwise the stem 26' of a disk 26, said stem being grooved, as at 26², to permit the free passage of air or steam. Surrounding the pipe 24 is a pipe 27, one end of which is threaded into the fitting 18 and communicates with the chamber 20 thereof, the other end of said pipe being flush with the end of the air-conduit 24.

In the modification represented in Fig. 4 the construction is the same as that just described, with the exception that air or steam is supplied under pressure directly to the pipe 23 by a pipe 28 and elbow 29, said pipe 28 passing through a packed gland 30 of the nipple 6.

It will be seen that the casing 5 and pipes 24 and 27, located below the top thereof, are concentrically disposed and that said casing 5 is of much larger diameter than the pipes, so that the air as it enters the casing expands to fill the same and is consequently reduced in pressure, while air or steam at high pressure may be admitted to the pipe 23.

My invention operates as follows: Valves 8 and 16 having been opened, air or steam under high pressure and oil also under pressure are supplied to the fitting 18 and air at low pressure to the casing 5. As the oil from pipe 17 is admitted to the burner, the quantity being regulated by the valve 16, it is thrown in a jet into chamber 19, passes from thence through passages 22 to chamber 20, and from said chamber to the pipe 27. Air or steam at high pressure enters pipe 23 and chamber 21 of fitting 18, and passing through pipe 24 and the grooves 26² in the stem of spreader 26 impinges against said spreader and is deflected thereby at right angles to said pipe 24, thereby atomizing the oil and carrying it into the moving column of air at low pressure in the casing 5. This mixture of air or steam and atomized oil is projected a short distance ahead of the end of casing 5, and being ignited thorough combustion takes place with the generation of intense heat suitable for smelting or other purposes.

It will be noticed that the free ends of pipes 26 and 27 are in the same plane below the spreader and that the oil is atomized and thrown off at exactly right angles to said ends into the casing 5, where it is again projected at right angles by the incoming column of air from pipe 10, and that consequently the oil does not come in contact with the wall of said casing, being prevented from doing so by such incoming air, and no film is therefore deposited thereon.

My improved burner is preferably disposed vertically, as shown, to accomplish the best results, although the invention is not limited to this disposition.

My invention is not limited to the exact construction shown and described, for changes may be made without departure therefrom, nor is it limited to any particular kinds of valves for regulating the admission of air or steam and oil thereto.

By the improved construction described the atomized oil is thoroughly diffused and commingled with air or steam and is thereby furnished with so much oxygen that all particles are thoroughly consumed without smell or smoke.

Having thus described my invention, what I claim is—

1. The combination, with a casing, of means for supplying air thereto; a fitting in said casing having end and intermediate chambers and means for connecting said end chambers; a pipe communicating with the intermediate chamber; conduits, one communicating with an end chamber of the fitting, and the other with the intermediate chamber thereof; and means for supplying fluid to the other end chamber.

2. In a hydrocarbon-burner, the combina-

tion, with a fitting having a pair of chambers, a chamber intermediate said pair of chambers, and means for connecting the pair of chambers, of inlet and outlet pipes communicating with the intermediate chamber; a pipe surrounding the outlet-pipe and communicating with one of the pair of chambers; a pipe communicating with the other of said pair of chambers; and means for supplying fluid to said pipe.

3. In a hydrocarbon-burner, the combination, with a casing, and with means for supplying air thereto, of a fitting having a pair of chambers, an intermediate chamber, and passages connecting the pair of chambers; an air or steam pipe communicating with the intermediate chamber; concentric conduits, one communicating with the intermediate chamber and the other with one of the pair of chambers; and means for supplying the fluid to be consumed to the other of said pair of chambers.

4. In a hydrocarbon-burner, the combination, with a fitting having end chambers and an intermediate chamber and passages connecting said end chambers, of pipes communicating with all of said chambers; means for supplying oil to one of said pipes and chambers; means for supplying air or steam to the intermediate chamber and to the other of said pipes; and means for causing said air or steam to commingle with the oil.

5. In a hydrocarbon-burner, the combination, with a fitting having a chamber at each end and passages connecting said chambers, of pipes communicating with said chambers; means for supplying air or steam to one of said pipes; means for projecting atomized oil at an angle to the end of the pipe to which air or steam is supplied; a casing surrounding the pipe; and means for supplying air to said casing.

6. The combination, with a fitting having end and intermediate chambers and passages connecting said end chambers, of means for supplying oil to one of the end chambers; a pipe for conveying air or steam to the intermediate chamber; a conduit for conveying air or steam from said intermediate chamber; and a pipe surrounding said conduit and communicating with the other end chamber.

7. The combination, with a fitting having a chamber in each of its ends and passages connecting them, of pipes fitted in said chambers; means for projecting oil into one of said pipes; a conduit concentric with the other of said pipes and having an end flush with the extremity thereof; a spreader; and means for conveying air or steam to said conduit.

8. The combination, with a fitting having end and intermediate chambers, and passages connecting the end chambers, of pipes fitted in said end chambers; a conduit concentric

with one of said pipes and communicating
with the intermediate chamber; means for
supplying air or steam to the intermediate
chamber; means for supplying oil to one of
5 the pipes in the end chambers; a spreader; a
casing surrounding the fitting and its pipes;
and means for supplying air to said casing.

In testimony whereof I affix my signature in
presence of two witnesses.

CHARLES W. SPONSEL.

Witnesses:

A. F. WOODS,
JESSIE B. WOODS.