

W. H. STANLEY.
 COMBINATION TOOL.
 APPLICATION FILED AUG. 15, 1910.

999,899.

Patented Aug. 8, 1911.

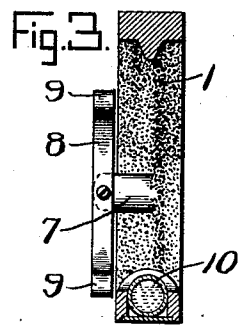
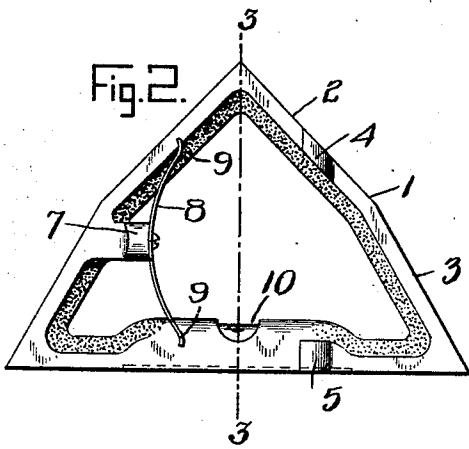
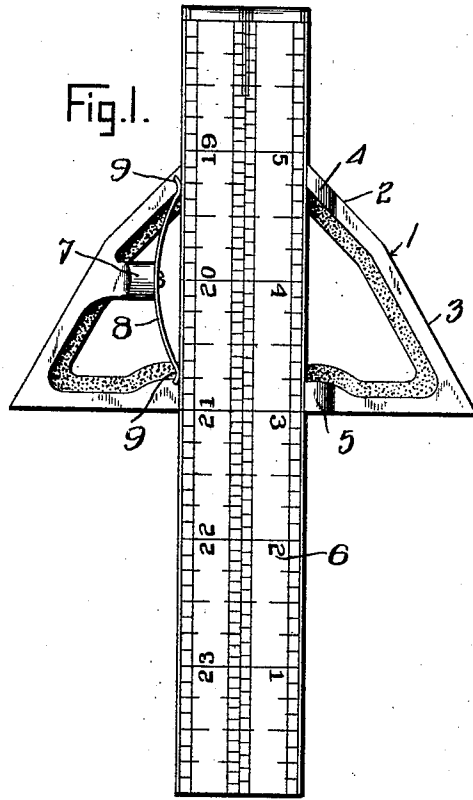

Witnesses

C. K. Reichenbach.
L. B. Marmaduke.

By

Inventor
William H. Stanley,
Edw. S. Newall, Jr.
 his Attorney

UNITED STATES PATENT OFFICE.

WILLIAM H. STANLEY, OF ALAMEDA, CALIFORNIA.

COMBINATION-TOOL.

999,899.

Specification of Letters Patent.

Patented Aug. 8, 1911.

Application filed August 15, 1910. Serial No. 577,290.

To all whom it may concern:

Be it known that I, WILLIAM H. STANLEY, a citizen of the United States, residing at Alameda, in the county of Alameda and State of California, have invented certain new and useful Improvements in Combination-Tools, of which the following is a specification.

This invention has reference, generally, to improvements in that class of instruments designed for use as squares, miters, marking-gages, and the like; and the present invention has for its principal object to provide a novel and simply constructed contrivance whereby it may be readily carried in the pocket or stored in the tool-chest and is capable of ready attachment to the ordinary foot-rule or the usual straight-edge for use in ascertaining or finding various degree angles and for use as a marking-gage, a depth-gage, a T-square, a try-square, a miter, and similar uses.

A further object of the invention is to provide for its use also as a spirit level.

The invention consists of certain instrumentalities or features substantially as hereinafter fully disclosed and defined by the claim.

In the accompanying drawings, illustrating the preferred embodiment of my invention and wherein the various details may be changed or modified as circumstances may require,

Figure 1 is a plan or top view of the instrument as applied to a foot-rule for use; and Fig. 2 is a similar view of the same detached from the rule. Fig. 3 is a vertical section taken on line 3—3 of Fig. 2.

Similar characters of reference are employed in the several views to indicate corresponding parts.

In carrying out my invention, I make the number 1 of substantially right-angled triangular outline, except that its inclined or diagonal sides are each adapted to extend partly at an angle of forty five degrees (45°) and partly at an angle of thirty degrees (30°) as at 2 and 3, respectively, the utility and convenience of which are apparent. For lightness and economy of construction the number 1, which is preferably a casting, is produced in skeleton form as shown. The member 1 has projecting therefrom, laterally of a line passing through its vertical center and a short distance away from such line, two alining lugs 4, 5 adapt-

ed to conform with nicety of adjustment to one of the smooth lateral edges of a foot-rule 6, as disclosed.

The member 1 is provided upon its opposite lateral portion with an outstanding stud or projection 7, at a point about equidistant from the lugs 4, 5, and to this stud is centrally secured, in any suitable way, as by means of a screw, or otherwise, a substantially semi-elliptic spring or clasp 8, with its terminals adapted to engage and deliver pressure upon the opposite lateral edge of the foot-rule. By this arrangement, it will be noted, that, with the foot-rule, in its folded position, inserted or interposed between the lugs 4 and 5 and the spring or clasp 8, which may be more readily effected by presenting the triangle or member 1 and rule 6 laterally toward each other, said triangle or member is effectively or forcibly clasped or held to the rule and yet adapted to be slid thereon in effecting the relative adjustment thereof as circumstances may suggest, all without the manual manipulation of the clasp or spring, or the holding means for the triangle, permitting the ready and expeditious application and adjustment of the triangle, together with the rule, simply by holding one and moving the other, the clasp yielding and regaining its grip automatically. The terminals of the spring or clasp 8 are reversely curved as at 9 thus providing for presenting smooth or non-mutilating surface of contact or engagement therebetween and the rule, as desirable.

The instrument may be readily used with the arms of the ordinary foot-rule, or with an ordinary straight-edge by placing the rule or straight-edge between the vertical faces of the lugs 4 and 5 and the terminal of the spring or clasp 8, as clearly evident. In this manner the tool and the foot-rule or straight-edge are securely connected against displacement from each other, the said tool being secured in any adjusted position along the graduation upon the face of the rule, that may be desired. It is also obvious from an inspection of Fig. 1 of the drawings, that when the device 1 has been secured in its position upon the rule, the entire contrivance may be used as a marking-gage, a depth-gage, a T-square, a try-square, or as a 45 or 30 degree miter for producing these various angles. By suitably applying lateral pressure to the triangle or member 1, it may be readily detached from the rule or

straight-edge as indicated in Fig. 2, and may be used as an ordinary inside square.

From an inspection of Fig. 1 of the drawings, it will be clearly seen that by holding the foot-rule in the one hand and suitably moving the triangle it may be slipped along the longitudinal edges of the rule or straight-edge, and upon bringing the triangle to rest the same will be instantly retained in position at its point of adjustment. If desired, the body may be provided upon any one of its inner faces with a spirit level preferably embedded in position therein as clearly illustrated in Fig. 2, the device also being adapted as a thumb-square, as suggested by Fig. 2.

The use of the device shown in the accompanying drawings is clearly apparent and need not be further described, suffice it to say, that when the device 1 is secured in position upon the rule in the manner indicated in Fig. 1, by placing the edge 11 against a board or the like, the parts may be used as an ordinary T-square for drawing or marking lines at right angles to the edge of the board; but when placing either of the edges 2 or 3 of the device against an edge of the board or the like, any one of the two longitudinal edges of the rule extending beyond the said edges 4 and 5 may be used for drawing lines at 45 or 30 degrees to the edge of the board as will be clearly evident; and, furthermore, when detached from the

rule, the device may be variously used as a square.

From the foregoing description of my invention, and an inspection of the accompanying drawings, it will be clearly seen that I have produced a device which may be quickly and easily attached to the rule or straight-edge for its various uses, and may be just as quickly detached therefrom, so as to be stored in the tool-chest, or that may be carried without discomfort in the pocket.

I claim:

A device of the character described, including a member, triangular in general outline, said member having lateral alining lugs arranged at one side of its center, the opposite arm of said member having an outstanding stud arranged at a point about equidistant between said lugs, said outstanding stud having a semi-elliptical spring secured about centrally thereto, the concavity of said spring being presented toward the center of said triangular member, the outer ends of said spring being adapted to engage an object interposed therebetween and said stud for the retention of said object in position upon said triangular member.

In testimony whereof I affix my signature in presence of two witnesses.

WILLIAM H. STANLEY.

Witnesses:

B. B. MCCARTHY,
JOHN M. GEARIN.