

(19) World Intellectual Property Organization
International Bureau



(43) International Publication Date
9 January 2003 (09.01.2003)

PCT

(10) International Publication Number
WO 03/002021 A2

- (51) International Patent Classification⁷: A61F
- (21) International Application Number: PCT/US02/16483
- (22) International Filing Date: 24 May 2002 (24.05.2002)
- (25) Filing Language: English
- (26) Publication Language: English
- (30) Priority Data:
60/301,882 29 June 2001 (29.06.2001) US
- (71) Applicant: THE REGENTS OF THE UNIVERSITY OF CALIFORNIA [US/US]; Office of the President, 1111 Franklin Street, 12th Floor, Oakland, CA 94607-5200 (US).

- (81) Designated States (*national*): AE, AG, AL, AM, AT, AU, AZ, BA, BB, BG, BR, BY, BZ, CA, CH, CN, CO, CR, CU, CZ, DE, DK, DM, DZ, EC, EE, ES, FI, GB, GD, GE, GH, GM, HR, HU, ID, IL, IN, IS, JP, KE, KG, KP, KR, KZ, LC, LK, LR, LS, LT, LU, LV, MA, MD, MG, MK, MN, MW, MX, MZ, NO, NZ, OM, PH, PL, PT, RO, RU, SD, SE, SG, SI, SK, SL, TJ, TM, TN, TR, TT, TZ, UA, UG, UZ, VN, YU, ZA, ZM, ZW.
- (84) Designated States (*regional*): ARIPO patent (GH, GM, KE, LS, MW, MZ, SD, SL, SZ, TZ, UG, ZM, ZW), Eurasian patent (AM, AZ, BY, KG, KZ, MD, RU, TJ, TM), European patent (AT, BE, CH, CY, DE, DK, ES, FI, FR, GB, GR, IE, IT, LU, MC, NL, PT, SE, TR), OAPI patent (BF, BJ, CF, CG, CI, CM, GA, GN, GQ, GW, ML, MR, NE, SN, TD, TG).

- (72) Inventors: LOTZ, Jeffrey, C.; 129 Castilian Way, Sausalito, CA 94965 (US). COLLIOU, Olivier, K.; 311 De Soto Drive, Los Gatos, CA 95032 (US). BRADFORD, David, S.; 9 Cloudview Road, Sausalito, CA 94965 (US).
- (74) Agent: O'BANION, John, P.; O'Banion & Ritchey LLP, Suite 1550, 400 Capitol Mall, Sacramento, CA 95814 (US).

Published:
— without international search report and to be republished upon receipt of that report

For two-letter codes and other abbreviations, refer to the "Guidance Notes on Codes and Abbreviations" appearing at the beginning of each regular issue of the PCT Gazette.

(54) Title: BIODEGRADABLE/BIOACTIVE NUCLEUS PULPOSUS IMPLANT AND METHOD FOR TREATING DEGENERATED INTERVERTEBRAL DISCS

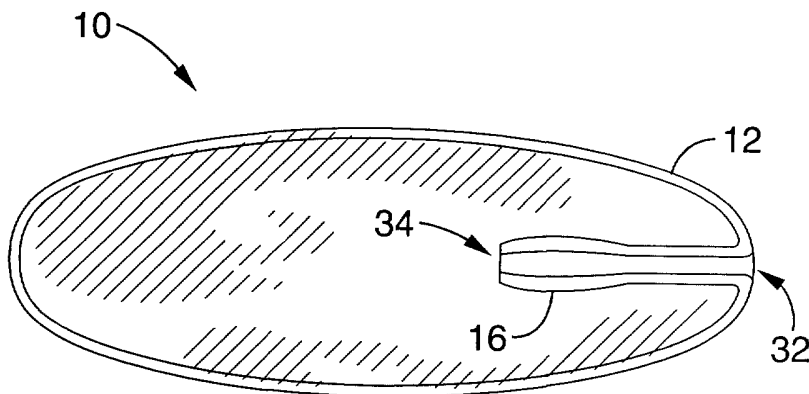

(57) Abstract: A bioactive/biodegradable nucleus implant for repairing degenerated intervertebral discs that is inflated inside the nucleus space after the degenerated nucleus has been removed to re-pressurize the nuclear space within the intervertebral disc. The implant is inflated with a high molecular weight fluid, gel or combination of fluid and elastomer, preferably an under-hydrated HA hydrogel/growth factor mixture with or without host cells. The implant includes an internal, integral, self-sealing valve that allows one-way filling of the implant after it is placed

within the disc, and is made from a material that allows fibrous in growth thereby stabilizing the implant. A variety of substances can be incorporated into the implant to promote healing, prevent infection, or arrest pain.



WO 03/002021 A2

BIODEGRADABLE/BIOACTIVE NUCLEUS PULPOSUS IMPLANT AND METHOD FOR TREATING DEGENERATED INTERVERTEBRAL DISCS

BACKGROUND OF THE INVENTION

5 1. Field of the Invention

The present invention pertains generally to repairing intervertebral disc disorders, and more particularly to an implant and surgical procedure for repairing a degenerated intervertebral disc.

2. Description of the Background Art

10 An estimated 4.1 million Americans annually report intervertebral disc disorders, with a significant portion of them adding to the nearly 5.2 million low-back disabled. Though the origin of low-back pain is varied, the intervertebral disc is thought to be a primary source in many cases, and is an initiating factor in others where a degenerated disc has led to altered spinal mechanics and non-physiologic
15 stress in surrounding tissues.

The intervertebral disc is a complex structure consisting of three distinct parts: the nucleus pulposus; the annulus fibrosus; and the cartilaginous end-plates. The nucleus pulposus is a viscous, mucoprotein gel that is approximately centrally located within the disc. It consists of abundant sulfated glycosaminoglycans in a
20 loose network of type II collagen, with a water content that is highest at birth (approximately 80%) and decreases with age. The annulus fibrosus is that portion of the disc which becomes differentiated from the periphery of the nucleus and forms the outer boundary of the disc. The transition between the nucleus and the annulus is progressively more indefinite with age. The annulus is made up of coarse type I
25 collagen fibers oriented obliquely and arranged in lamellae which attach the adjacent vertebral bodies. The fibers run the same direction within a given lamella but opposite to those in adjacent lamellae.* The collagen content of the disc steadily increases from the center of the nucleus to the outer layers of the annulus, where collagen reaches 70% or more of the dry weight. Type I and II collagen are
30 distributed radially in opposing concentration gradients. The cartilaginous end-plates cover the end surfaces of the vertebral bodies and serve as the cranial and caudal surfaces of the intervertebral disc. They are composed predominately of hyaline cartilage.

The disc derives its structural properties largely through its ability to attract and retain water. The proteoglycans of the nucleus attract water osmotically, exerting a swelling pressure that enables the disc to support spinal compressive loads. The pressurized nucleus also creates tensile pre-stress within the annulus and ligamentous structures surrounding the disc. In other words, although the disc principally supports compressive loads, the fibers of the annulus experience significant tension. As a result, the annular architecture is consistent with current remodeling theories, where the $\pm 60^\circ$ orientation of the collagen fibers, relative to the longitudinal axis of the spine, is optimally arranged to support the tensile stresses developed within a pressurized cylinder. This tissue pre-stress contributes significantly to the normal kinematics and mechanical response of the spine.

When the physical stress placed on the spine exceeds the nuclear swelling pressure, water is expressed from the disc, principally through the semipermeable cartilaginous end-plates. Consequently, significant disc water loss can occur over the course of a day due to activities of daily living. For example, the average diurnal variation in human stature is about 19 mm, which is mostly attributable to changes in disc height. This change in stature corresponds to a change of about 1.5 mm in the height of each lumbar disc. Using cadaveric spines, researchers have demonstrated that under sustained loading, intervertebral discs lose height, bulge more, and become stiffer in compression and more flexible in bending. Loss of nuclear water also dramatically affects the load distribution internal to the disc. In a healthy disc under compressive loading, compressive stress is created mainly within the nucleus pulposus, with the annulus acting primarily in tension. Studies show that, after three hours of compressive loading, there is a significant change in the pressure distribution, with the highest compressive stress occurring in the posterior annulus. Similar pressure distributions have been noted in degenerated and denucleated discs as well. This reversal in the state of annular stress, from physiologic tension due to circumferential hoop stress, to non-physiologic axial compression, is also noted in other experimental, analytic and anatomic studies, and clearly demonstrates that nuclear dehydration significantly alters stress distributions within the disc as well as its biomechanical response to loading.

The most consistent chemical change observed with degeneration is loss of proteoglycan and concomitant loss of water. This dehydration of the disc leads to loss of disc height. In addition, in humans there is an increase in the ratio of keratan

5 sulphate to chondroitin sulphate, an increase in proteoglycan extractability, and a decrease in proteoglycan aggregation through interaction with hyaluronic acid (although the hyaluronic acid content is typically in excess of that needed for maximum aggregation). Structural studies suggest that the non-aggregable
10 proteoglycans lack a hyaluronate binding site, presumably because of enzymatic scission of the core protein by stromelysin, an enzyme which is thought to play a major role in extracellular matrix degeneration. These proteoglycan changes are thought to precede the morphological reorganization usually attributed to degeneration. Secondary changes in the annulus include fibrocartilage production
15 with disorganization of the lamellar architecture and increases in type II collagen.

Currently, there are few clinical options to offer to patients suffering from these conditions. These clinical options are all empirically based and include (1) conservative therapy with physical rehabilitation and (2) surgical intervention with possible disc removal and spinal fusion. In contrast to other joints, such as the hip
20 and knee, very few methods of repair with restoration of function are not available for the spine.

Therefore, there is a need for a minimally invasive treatment for degenerated discs which can repair and regenerate the disc. The present invention satisfies that need, as well as others, and overcomes the deficiencies associated with
25 conventional implants and treatment methods.

BRIEF SUMMARY OF THE INVENTION

The present invention comprises an implant and minimally invasive method of treating degenerated discs which can repair and regenerate the disc. More particularly, the present invention comprises a bioactive/biodegradable nucleus
30 implant and method of use. The implant is inflated inside the nucleus space after the degenerated nucleus has been removed to re-pressurize the nuclear space within the intervertebral disc. Nuclear pressure produces tension in the annular ligament that increases biomechanical stability and diminishes hydrostatic tissue pressure that can stimulate fibro-chondrocytes to produce inflammatory factors. The device will
also increase disc height, separate the vertebral bodies and open the spinal foramina.

By way of example, and not of limitation, an implant according to the invention comprises a collapsible, textured or smooth membrane that forms an inflatable balloon or sack. To inflate the implant, the implant is filled with a high molecular

weight fluid, gel or combination of fluid and elastomer, preferably an under-hydrated HA hydrogel/growth factor mixture with or without host cells. Integral to the membrane is a self-sealing valve that allows one-way filling of the implant after it is placed within the disc. The implant membrane is made from a material that allows
5 fibrous in-growth thereby stabilizing the implant. A variety of substances can be incorporated into the device to promote healing, prevent infection, or arrest pain. The implant is inserted utilizing known microinvasive technology. Following partial or total nucleotomy with a small incision, typically annular, the deflated implant is inserted into the nuclear space through a cannula. The implant is then filled through
10 a stem attached to the self-sealing valve. Once the implant is filled to the proper size and pressure, the cannula is removed and the annular defect is sealed.

One of the main difficulties in repairing the degenerated disc is increasing the disc height. The disc and surrounding tissues such as ligaments provide a great deal of resistance to disc heightening. For this reason it is unlikely that placing a
15 hydrogel alone into the nuclear space will be able to generate enough swelling pressure to regain significant disc height. The present invention, however, addresses this problem by allowing initial high pressures to be generated when the implant is inflated in the nuclear space. The initial high pressure is sufficient to initiate the restoration of the original disc height. This initial boost in disc height
20 facilitates the later regeneration stages of this treatment.

In the long term, having a permanent pressurized implant is not likely to be ideal because it may not be able to mimic the essential biomechanical properties of the normal disc. However, the invention also addresses this issue by using a
25 biodegradable sack. The initially impermeable membrane permits high pressurization. When the membrane biodegrades, it allows the hydrogel mixture to take action in playing the role of the normal nucleus pulposus with its inherent swelling pressure and similar mechanical properties.

A variety of growth factors or other bioactive agents can be attached to the surface of the implant or included in the hydrogel mixture that is injected inside the
30 implant. The membrane could be reinforced or not reinforced with a variety of fiber meshes if necessary. Furthermore, a variety of materials could be used for the membrane; the only requirement is that they be biodegradable such that the membrane is impermeable when initially implanted and until it biodegrades. A variety of materials could be injected into the sack such as cartilage cells, alginate

gel, and growth factors.

An advantage of the invention is to provide for minimally invasive disk repair.

Another advantage of the invention is to provide a biodegradable implant.

Another advantage of the invention is to provide for restoration of disc height
5 and normal disc biomechanics.

Another advantage of the invention is to provide for disk repair with no loss of mobility.

Another advantage of the invention is to provide for strong integration of an implant with surrounding tissue.

10 Another advantage of the invention is to provide for disk repair through the use of a very small incision in the annulus.

Another advantage of the invention is to provide an implant that has a bioactive surface.

Another advantage of the invention is to provide for disk repair with very low
15 risk of re-herniation.

Another advantage of the invention is to provide a minimally invasive treatment for degenerated discs which can repair and regenerate the disc.

Another advantage of the invention is to provide a bioactive/biodegradable nucleus implant which can be inflated inside the nucleus space, such as after the
20 degenerated nucleus has been removed.

Further advantages of the invention will be brought out in the following portions of the specification, wherein the detailed description is for the purpose of fully disclosing preferred embodiments of the invention without placing limitations
thereon.

25 BRIEF DESCRIPTION OF THE DRAWINGS

The invention will be more fully understood by reference to the following drawings which are for illustrative purposes only:

FIG. 1 is a side view of an implant according to the present invention, shown in a collapsed state.

30 FIG. 2 is a side view of the implant of FIG. 1, shown in an inflated state, with a portion of the membrane cut away to show the internal filler material.

FIG. 3 is cross-sectional side view of the implant of FIG. 1, shown in the inflated state and showing the integral, internal fill valve.

FIG. 4 is a side view of a mandrel for molding an implant according to the present invention.

FIG. 5 is a side view of an implant membrane according to the present invention as it would be seen after being dip molded on the mandrel shown in FIG. 4
5 but before removal from the mandrel.

FIG. 6 is an end view of the implant shown in FIG. 5 prior to heat-sealing the open end.

FIG. 7 is an end view of the implant shown in FIG. 5 after heat-sealing the open end.

10 FIG. 8 is an exploded view of a delivery system for placement of an implant according to the invention shown in relation to the implant.

FIG. 9 is an assembled view of the delivery stem shown in FIG. 8 with the implant attached.

15 FIG. 10 is a side schematic view of a degenerated intervertebral disc prior to repair using an implant according to the present invention.

FIG. 11A through FIG. 11G is a flow diagram showing a surgical procedure for placement of an implant according to the present invention.

20 FIG. 12 is a perspective view of an introducer sheath according to the invention with a trocar inserted and positioned in the nuclear space of an intervertebral disc so as to create an annular opening in the disc.

FIG. 13 is a perspective view of a Crawford needle and Spine Wand inserted in the introducer sheath shown in FIG. 12 and positioned for ablation of the nuclear pulposus in an intervertebral disc.

FIG. 14 is a detail view of the implant end portion of the assembly of FIG. 13.

25 FIG. 15 is a perspective view of an implant launcher and fill assembly according to the present invention shown with an introducer sheath, launcher sheath, fill tube positioned prior to deployment of an implant in the nuclear space of an intervertebral disc and with the proximal end portions of the introducer sheath and launcher sheath partially cut away to expose the implant and buttress.

30 FIG. 16 is a detail view of the implant end portion of the assembly of FIG. 15.

FIG. 17 is a perspective view of the assembly of FIG. 15 after insertion of the implant in the nuclear space of the intervertebral disc.

FIG. 18 is a detail view of the implant end portion of the assembly of FIG. 17.

FIG. 19 a perspective view of the assembly of FIG. 15 after deployment of the implant in the nuclear space and prior to retraction of the implant and inner annular buttress.

FIG. 20 is a detail view of the implant end portion of the assembly of FIG. 19.

5 FIG. 21 is a perspective view of the assembly of FIG. 15 after partial retraction of the implant and inner annular buttress with the inner annular buttress shown engaging and plugging the annular opening in the intervertebral disc.

FIG. 22 is a detail view of the implant end portion of the assembly of FIG. 21.

10 FIG. 23 is a perspective view of the assembly of FIG. 15 after the implant is inflated.

FIG. 24 is a detail view of the implant end portion of the assembly of FIG. 23.

DETAILED DESCRIPTION OF THE INVENTION

For illustrative purposes, the present invention is embodied in the method and apparatus described herein and generally shown in FIG. 1 through FIG. 24. It will be
15 appreciated that the apparatus may vary as to configuration and as to details of the structure, and that the method may vary as to the specific steps and sequence, without departing from the basic concepts as disclosed herein.

Referring first to FIG. 1 through FIG. 3, an implant 10 according to the present invention comprises a collapsible membrane 12 that is formed into a inflatable
20 balloon or sack that will conform to the shape of the nucleus pulposus when inflated.

Membrane 12 preferably comprises an inert material such as silicone or a similar elastomer, or a biodegradable and biocompatible material such as poly (DL-lactic-co-glycolic acid; PLGA). Since the implant will serve as an artificial inner annulus, and its internal chamber will contain a pressurized nuclear filler material 14 used for
25 inflation, the membrane material should be relatively impermeable while possessing the necessary compliance and strength. In addition, the membrane material should be sufficiently flexible so that the implant can easily be passed through a surgical catheter or cannula for insertion.

Table 1 compares certain characteristics of the inner annulus to a number of
30 commercially-available elastomers that were considered for the membrane material.

Key design requirements were biocompatibility, stiffness, and elongation-to-failure. While any of these materials, as well as other materials, can be used, our preferred material was aliphatic polycarbonate polyurethane (HT-4) which has a stiffness that closely approximates that of the inner annulus, can be fabricated into complex

shapes using dip molding, possess significant failure properties, and has a track-record for in vivo use.

The peripheral surface of the implant is preferably coated with one or more bioactive substances that will promote healing of the inner annulus and integration of the implant with the surrounding annular tissue. Also, the top and bottom surfaces of the implant are preferably coated with one or more bioactive substances that will promote healing of the cartilaginous endplates and integration of the implant with the endplates.

To limit the amount of lateral bulging when the implant is axially compressed, the peripheral surface of the implant can be reinforced with a fiber matrix if desired. In that event, the angle of the fibers relative to the vertical axis of placement should be approximately $\pm 60^\circ$ to closely approximate that of the native collagen fibers in the inner annulus.

Implant 10 includes an integral, internal, self-sealing, one-way valve 16 that will allow the implant to be inserted in a deflated state and then be inflated in situ without risk of deflation. Valve 16 functions as a flapper valve to prevent leakage and maintain pressurization of the implant when pressurized with the nuclear filler material. Because valve 16 is internal to the implant, compression of implant 10 will place internal pressure on valve 16 to keep it in a closed position. Due to the self-sealing nature of valve 16, the same pressure that might be sufficient to allow the nuclear filler material to escape will cause valve 16 to remain closed so as to create a barrier to extrusion.

To better understand the operation and configuration of valve 16, reference is now made to FIG. 4 which shows the preferred embodiment of a mandrel 18 for fabricating the implant. Mandrel 18 preferably comprises a planar stem portion 20, a first cylindrical base portion 22, a mold portion 24, a second cylindrical base portion 26, and a shank 28. To fabricate an implant, distal end 30 of the mandrel is dipped in a bath of membrane material to a defined depth which is generally at a point along second base portion 26 and molded to a thickness between approximately 5 mils and 7 mils.

FIG. 5 generally depicts the configuration of the implant after it has dried on the mandrel. However, the mandrel is not shown in FIG. 5 so that the implant can be more clearly seen. After the membrane material dries on the mandrel, it is drawn off of the mandrel by rolling it toward distal end 30. As a result, the membrane is turned

inside-out. By inverting the membrane in this manner, the portion of membrane material that coated stem portion 20 becomes valve 16 which is now located inside the implant as shown in FIG. 3. The portion of membrane material that coated first base portion 22 becomes an entrance port 32 into valve 16. Note that the distal end 5 34 of valve 16 was sealed during molding, while the distal end 36 of the implant is still open as shown in FIG. 5 and FIG. 6. Accordingly, to finish the fabrication process, distal end 36 of the implant is heat-sealed to close it off as shown in FIG. 7.

To inflate the implant, a needle-like fill stem is inserted through entrance port 32 so as to puncture the distal end 34 of valve 16 and extend into the interior 10 chamber of the implant. The implant is then filled with a fluid material, such as a high molecular weight fluid, gel or combination of fluid and elastomer which has a viscosity that will permit its introduction into the implant through, for example, an 18-gauge needle. The specific properties of filler material 14 should allow the material to achieve and maintain the desired osmotic pressure. The filling takes place after 15 the implant is placed within the disc. Preferably filler material is a cross-linkable polyethylene glycol (PEG) hydrogel with chondroitin sulfate (CS) and hyaluronic acid (HA) with or without host cells as will now be described.

Table 2 shows the characteristics of a number of commercially-available hydrogels that were considered for filler material 14. While any of these materials, 20 as well as other materials, can be used, we selected an in situ cross-linkable polyethylene glycol (PEG) gel because of its bio-compatibility and physical properties. The PEG gel is a two component formulation that becomes a low-viscosity fluid when first mixed and which cross-links to a firm gel after insertion. The cross-link time depends on the formulation. A key feature of the gel is its osmotic 25 pressure. We sought to formulate a gel that would possess an osmotic pressure of near 0.2 MPa which is that of the native nucleus pulposus.

The preferred PEG gel comprises a nucleophilic "8-arm" octomer (PEG-NH₂, MW 20 kDa) and a "2-arm" amine-specific electrophilic dimer (SPA-PEG-SPA, MW 3.4 kDa), and is available from Shearwater Corporation, Huntsville, Alabama. The 30 addition-elimination polymerization reaction culminates in a nitrogen-carbon peptide-like linkage, resulting in a stable polymer whose rate of polymerization increases with pH and gel concentration. The range of pH (approximately 10 for the unmodified gel) and concentration (approximately 0.036 g/mL to 0.100 g/mL) investigated resulted in a polymerization time of approximately 10 minutes to 20 minutes. To fortify the.

hydrogel's inherent swelling due to hydrogen bonding, high molecular weight additives chondroitin sulfate (CS) and hyaluronic acid (HA) with established fixed charged densities were incorporated into the gel matrix.

The swelling pressures of the hydrogel filler (cross-linked polyethylene glycol (PEG) hydrogels and derivatives incorporating HA and CS) were measured by equilibrium dialysis as a function of gel and additive concentration. Polyethylene glycol (Molecular Weight 20 kDa available from Sigma-Aldrich Corporation) was also used as the osmotic stressing agent, while molecularporous membrane tubing was used to separate sample gels from the dialysate. Gels were formed over a broad concentration range (0.036 to 0.100 g/mL), weighed, placed in dialysis tubing (Spectra/Por Membrane, Molecular Weight Cut Off of 3.5 kDa available from Spectrum Medical Industries), and allowed to equilibrate for 40 to 50 hours in the osmotic stressing solution, weighed again to determine hydration, then oven dried (at 60 degrees Celsius) and weighed once again. Hydration values taken at various osmotic pressures allowed the construction of osmotic pressure curves. By adjusting the concentrations of CS or HA we were able to meet our design criteria, successfully achieving swelling pressures above 0.2 MPa. A potential deleterious interaction between the elastomer and hydrogel was noted. One PEG-CS specimen aged in saline demonstrated breakdown of the elastomer shell. This may have been due to the relatively low-molecular weight CS penetrating into the membrane material (polyurethane) leading to an increased rate of hydrolysis.

Referring now to FIG. 8 and FIG. 9, the invention includes an implant delivery system comprising a hollow implant fill stem 38, a hollow buttress positioner 40, and an inner annular buttress 42. Implant fill stem 38 is configured for inflating implant 10 after insertion, and inner annular buttress 42 is configured to extend into and block a hole 66 (see FIG. 11A) that is made in the annulus for insertion of implant 10. Once inserted, inner annular buttress 42 prevents extrusion of the implant during spinal loading. Inner annular buttress 42 preferably comprises a polymer head portion 44 of suitable diameter for plugging hole 66, a smaller diameter polymer body portion 46 extending from head portion 44, and metal barbs or pins 48 having ends 50 that extend outward in relation to body portion 46 such that they will engage the annulus to prevent expulsion of inner annular buttress 42 (and implant 10) during spinal loading. Pins 48, which can be formed of stainless steel, Nitinol®, or the like, can be molded or otherwise inserted into head portion 44 for retention therein.

An inner passage 52 extends through inner annular buttress 42 for attachment to buttress positioner 40 and insertion of fill stem 38 through inner annular buttress 42 into implant 10. Inner passage 52, head portion 44 and body portion 46 are preferably coaxial. Buttress positioner 40 and inner annular buttress 42 are coupled together using mating threads 54a, 54b or another form of detachable coupling that allows buttress positioner 40 to be easily removed from inner annular buttress 42 after placement. Note that inner annular buttress 42 can be attached to implant 10 using adhesives, ultrasonic welding or the like, or can be separate and unattached from implant 10.

Fill stem 38 includes a collar 56 for attachment to a syringe 58 or other device to be used for inflating the implant with the filler material. Fill stem 38 and syringe 58 are coupled together using threads (not shown) or another form of detachable coupling. Preferably, syringe 58 includes a pressure gauge (not shown) for determining the proper inflation pressure. The implant and delivery system would be deployed into the nucleus pulposus space by being inserted into a conventional catheter, cannula or the like (not shown) having a retractable cover (not shown) that protects the implant during insertion.

FIG. 10 depicts the vertebral bodies 60, cartilage endplates 62, degenerated nucleus 64, and degenerated annulus 66 in the spine. The indications for use of the implant are a patient with back pain or radiating pain down the leg where the cause of the pain has been determined to be a herniated disc which is impinging on the surrounding spinal nerves. Deployment of the implant is preferably according to the following surgical procedure shown in FIG. 11A through FIG. 11G which is minimally invasive.

As shown in FIG. 11A, the first step in the surgical procedure is to perform a minimally invasive postero-lateral percutaneous discectomy. This is executed by making a small hole 68 through the annulus fibrosus of the intervertebral disc and removing the nucleus pulposus tissue through that hole. Several technologies were considered to facilitate removing degenerated nuclear material through a small opening made through the annulus fibrosus. The most promising technology is the ArthroCare Coblation probe (ArthroCare Spine, Sunnyvale, California). This device vaporizes the nucleus in situ. Because of density differences that exist between the nucleus and annulus, the Coblation probe removes the less-dense nuclear material more easily than the annulus. This allows the surgeon to remove the nuclear

material while minimizing damage to the remaining annulus or adjacent vertebral body.

The referred protocol for creating a nuclear space for the implant comprises making a small puncture within the annulus with a pointed, 3 mm diameter probe.

5 This pointed probe serves to separate annular fibers and minimize damage to the annulus. Next, a portion of the nucleus is removed using standard surgical instruments. The Coblation probe is then inserted. Suction and saline delivery are available with the probe, although we have found that suction through another portal using, for example, a 16-gage needle, may be required. A critical feature of device
10 success is the method of creating a nuclear space while minimizing trauma to the outer annulus fibrosus. The outer annulus should be preserved, as it is responsible for supporting the implant when pressurized.

Next, as shown in FIG. 11B, the deflated implant 10 is inserted into the empty nuclear space 70. This is accomplished by inserting the implant through a
15 conventional insertion catheter (cannula) 72. Note that fill stem 38, buttress positioner 40 and inner annular buttress 42 are also inserted through catheter 72, which also results in compression of pins 48. The cover 74 on the insertion catheter 72 is then retracted to expose the implant as shown in FIG. 11C. Next, as shown in FIG. 11D, the implant is inflated with the filler material 14, until it completely fills the
20 nuclear space 70. FIG. 11E shows the implant fully inflated. Note the resultant increase in disc height and restoration of tensile stresses in the annulus. The pressurized implant initiates the restoration of the original biomechanics of the healthy disc by increasing the disc height, relieving the annulus of the compressive load, and restoring the normal tensile stress environment to the annulus. The
25 restoration of the normal tensile stress environment in the annulus will promote the annular cells to regenerate the normal annulus matrix.

The catheter and delivery system (e.g., fill stem 38 and buttress positioner 40) are then removed, leaving inner annular buttress 42 in place and implant 10 sealed in position as shown in FIG. 11F. Note that inner annular buttress 42 not only serves
30 to align and place the implant, but prevents extrusion during spinal loading. In addition, the one-way valve 16 in the implant prevents the hydrogel/ growth factor mixture from leaking back out of the nucleus implant. Therapeutic agents on the peripheral and top/bottom surfaces of the implant stimulate healing of the inner annulus and cartilage endplates. In addition the surface growth factors will also

promote integration of the implant with the surrounding tissue.

Finally, FIG. 11G depicts the implant biodegrading after a predetermined time so as to allow the hydrogel/ growth factor mixture to play its bioactive role. The hydrogel is hydrophilic and thereby attracts water into the disc. Much like the healthy
5 nucleus pulposus, the hydrogel creates a swelling pressure which is essential in normal disc biomechanics. The growth factor which is included in the hydrogel stimulates cell migration, and proliferation. We expect the environment provided for these cells to stimulate the synthesis of healthy nucleus pulposus extracellular matrix components (ECM). These cells will thereby complete the regeneration of the
10 nucleus pulposus.

It will be appreciated that the implant can be inserted using other procedures as well. For example, instead of performing a discectomy (posterolateral or otherwise), the implant could be inserted into a preexisting void within the annulus that arises from atrophy or other form of non-device-induced evacuation of the
15 nucleus pulposus, such as for, example, by leakage or dehydration over time.

Example 1

Prototype implant shells were fabricated by Apex Biomedical (San Diego, CA). The fabrication process included dip molding using a custom-fabricated mandrel. The mandrel was dipped so that the elastomer thickness was between 5 and 7 mils
20 (0.13-0.17 mm). After dipping, the implant was removed from the mandrel, inverted (so that the stem was inside the implant) and heat-sealed at the open end. This process resulted in a prototype that could be filled with the PEG gel, which when cross-linked could not exit through the implant stem. The stem effectively sealed the implant by functioning as a "flapper valve". This means that by being placed within
25 the implant, internal pressures (that might serve to extrude the gel) compress and seal the stem, creating a barrier to extrusion. This sealing mechanism was verified by in vitro testing.

Example 2

Elastomer bags filled with PEG were compressed to failure between two
30 parallel platens. The implants failed at the heat seal at approximately 250 Newtons force. These experiments demonstrated that under hyper-pressurization, the failure mechanism was rupture at the sealed edge, rather than extrusion of gel through the insertion stem. When the device is placed within the intervertebral disc, support by the annulus and vertebral body results in a significantly increased failure load and

altered construct failure mechanism.

Example 3

Ex vivo mechanical testing were performed with human cadaveric spines to characterize the performance of the device under expected extreme in vivo
5 conditions. We conducted a series of experiments that consisted of placing the device in human cadaveric discs using the developed surgical protocols and then testing the construct to failure under compressive loading. The objective of these experiments was to characterize the failure load and failure mechanism. The target failure load was to exceed five times body weight (anticipated extremes of in vivo
10 loading). Importantly, the failure mode was to be endplate fracture and extrusion of the implant into the adjacent vertebra. This is the mode of disc injury in healthy spines. We did not want the construct to fail by extrusion through the annulus, particularly through the insertion hole, since this would place the hydrogel in close proximity to sensitive neural structures.

15 Load-to-failure experiments demonstrated that the implant may sustain in excess of 5000 N (approximately seven times body weight) before failure, and that the failure mode was endplate fracture. These preliminary experiments demonstrate that the implant can sustain extremes in spinal compression acutely.

Referring now to FIG. 12, the nuclear space can be prepared for receiving the
20 implant by removing degenerated nuclear material using a coblation probe or the like as described above. Upon exposing the targeted disc 100, the nuclear space 102 can be accessed via a trocar 104, such as a stainless steel, 7 Fr. OD, trocar with a small Ultem handle 106. Preferably, a corresponding 7 Fr introducer sheath 108 also having a small Ultem handle 110, is used for insertion of the trocar. An example
25 of a suitable introducer sheath is a 7 Fr plastic sheath with 0.003 inch walls and a 1.5 inch working length, such as a modified Cook or equivalent. The trocar is then removed upon access leaving a patient access point. Use of an introducer tends to minimize wear and tear on the hole, thus maximizing engagement of inner annular buttress 42. In the embodiment shown, inner annular buttress 42 would typically
30 have a 0.071 OD and a length of 0.070 inches, and carry three pins 48 having a diameter of approximately 0.008 inches and a length of approximately 0.065 inches.

Referring to FIG. 13 and FIG. 14, a Crawford needle 112 (e.g., 17 gage x 6 inch, included with the ArthroCare Convenience Pack Catalog No. K7913-010) and ArthroCare Perc-DLE Spine Wand 114 (ArthroCare catalog number K7813-01) are

introduced into the nucleus through the introducer sheath 108 and the nucleus pulposus is ablated. By moving the Wand in and out of the needle, the degree of articulation of the distal tip can be controlled. The Crawford needle also provides added rigidity for improved manipulation of the device.

5 Referring now to FIG. 15 and FIG. 16, an alternative embodiment of the delivery system shown in FIG. 8 and FIG. 9 is illustrated. In this embodiment, introducer sheath 108 is used as a port into the nuclear space 102. In FIG. 15, the end portion of introducer sheath 18 has been cutaway for clarity. A plastic launcher sheath 116 (e.g., 0.084 inch x 0.090 inch x 3 inch) is slidably insertable into the
10 introducer sheath is provided. Note that the end portion of launch sheath 116 has also been cutaway for clarity. Preferably, launcher sheath 116 includes a small plastic handle 118, and all or a portion of the launcher sheath is preferably flexible to assist with deployment of the implant as described below. A fill tube 120 (e.g., 14 XT x 3.9 inch long) is provided that is slidably insertable into launcher sheath 116. Fill
15 tube 120 also preferably includes a small plastic handle 122. The fill tube preferably terminates at its proximal end with a female leur lock 124 having a 0-80 UNF thread to which the assembly of buttress 42 (carrying implant 10) is threadably attached. It will be appreciated that buttress 42 can be attached to leur lock 124 after fill tube 120 has been inserted into launcher sheath 116 and extended therethrough such that
20 leur lock 124 extends through the end of launcher sheath 116. At this point pins 48 can be manually depressed and the un-deployed implant/buttress assembly pulled into the launcher sheath. Alternatively, buttress 42 can be attached to leur lock 124 and fill tube 120 then inserted into launcher sheath 116. With either approach, the assembly of implant 10, buttress 42, launcher sheath 116 and fill tube 120 can then
25 be inserted into introducer sheath 108 and pushed into the nuclear space 102. A small c-clip style spacer or the like (not shown) can be used to maintain separation between handles 118 and 122 to prevent premature deployment of the implant as will be more fully appreciated from the discussion below.

As can be seen from FIG. 17 and FIG. 18, implant 10 can then be advanced
30 into the nuclear space 102 by pushing launcher sheath 116 through introducer sheath 108 until handle 118 contacts handle 110. Note that the flexibility of launcher sheath 106 allows it to deflect if necessary to fit the contour of the nuclear space. FIG. 19 and FIG. 20 then show the implant being deployed by retracting both the introducer sheath 108 and the launcher sheath 116 by pulling handles 110 and 118

back toward handle 122 on fill tube 120 until they are in contact with handle 122. From FIG. 20 it can be seen that pins 48 will then spring outward into the nuclear space and into a position that is ready for engagement with the annulus. Then, as can be seen in FIG. 21 and FIG. 22, pulling back on fill tube 120 will cause the pins
5 48 on buttress 42 to engage the annulus 68. With inner annular buttress 42 secured in place, implant 10 can then be filled as shown in FIG. 23 and FIG. 24. Once
implant 10 is filled, fill tube 120 can be unscrewed from buttress 42 and removed.

Although the description above contains many specificities, these should not be construed as limiting the scope of the invention but as merely providing
10 illustrations of some of the presently preferred embodiments of this invention. Those skilled in the art will appreciate that other materials, structures, components, and configurations can be employed without departing from the invention. For example, collagen could be used instead of polymer, and polylysine or type 2 collagen with a cross-linking agent could be used instead of hydrogel. Therefore, it
15 will be appreciated that the scope of the present invention fully encompasses other embodiments which may become obvious to those skilled in the art, and that the scope of the present invention is accordingly to be limited by nothing other than the appended claims, in which reference to an element in the singular is not intended to mean "one and only one" unless explicitly so stated, but rather "one or more." All
20 structural, chemical, and functional equivalents to the elements of the above-described preferred embodiment that are known to those of ordinary skill in the art are expressly incorporated herein by reference and are intended to be encompassed by the present claims. Moreover, it is not necessary for a device or method to address each and every problem sought to be solved by the present invention, for it
25 to be encompassed by the present claims. Furthermore, no element, component, or method step in the present disclosure is intended to be dedicated to the public regardless of whether the element, component, or method step is explicitly recited in the claims. No claim element herein is to be construed under the provisions of 35
U.S.C. 112, sixth paragraph, unless the element is expressly recited using the
30 phrase "means for."

Table 1
Elastomer Properties

Material	Description	Supplier	Modulus (psi)	Modulus (MPa)	Tensile strength (psi)	Tensile Strength (MPa)	Elongation (%)
Inner Annulus				5 to 10		1 to 3	10 to 20
HT-3	aliphatic polycarbonate polyurethane	Apex Medical	295.00	2.03	5300.00	36.54	470.00
HT-4	aliphatic polycarbonate polyurethane	Apex Medical	990.00	6.83	7100.00	48.95	375.00
HT-6	polycarpralactone copolyester polyurethane	Apex Medical	290.00	2.00	5800.00	39.99	850.00
HT-7	aromatic polyester polyurethane	Apex Medical	340.00	2.34	9000.00	62.06	550.00
HT-8	aliphatic polyether polyurethane	Apex Medical	290.00	2.00	5500.00	37.92	710.00
HT-9	aromatic polyester polyurethane	Apex Medical	550.00	3.79	7000.00	48.27	550.00

Table 2
Osmotic Pressure as a Function of Gel Formulation

Gel Formulation	[PEG]	[HA]	[CS]	Π (MPa)
1	3.6%	0.11%	-	0.011
2	5.0%	-	-	0.025
3	5.0%	-	0.68%	0.028
4	6.0%	-	-	0.033
5	7.5%	-	-	0.052
6	7.5%	2%	-	0.080
7	7.5%	-	6%	0.130
8	7.5%	3%	-	0.155
9	7.5%	-	11%	0.220
10	9%	-	13%	0.310
11	10%	-	15%	0.332

- 5 The additives in formulation #8 consisted of a pre-swollen HA-PEG gel that was dried then finely cut and incorporated into a new PEG gel.

CLAIMS

What is claimed is:

1. An implant for repairing an intervertebral disc, comprising:
an inflatable membrane;
5 said membrane having an internal chamber;
said membrane having an integral, internal self-sealing fill valve.
2. An implant as recited in claim 1, wherein said membrane comprises an
elastomer.
- 10 3. An implant as recited in claim 2, wherein said elastomer is
biodegradable.
4. An implant as recited in claim 2, wherein said elastomer comprises
15 polyurethane.
5. An implant as recited in claim 4, wherein said polyurethane comprises
aliphatic polycarbonate polyurethane.
- 20 6. An implant as recited in claim 1, wherein said chamber is filled with a
hydrogel.
7. An implant as recited in claim 6, wherein said hydrogel comprises
cross-linkable polyethylene glycol.
- 25 8. An implant as recited in claim 6, wherein said hydrogel is mixed with an
additive selected from the group consisting essentially of chondroitin sulfate and
hyaluronic acid.
- 30 9. An implant as recited in claim 6, wherein said hydrogel comprises:
a nucleophilic "8-arm" octomer (PEG-NH₂, MW 20 kDa); and
a "2-arm" amine-specific electrophilic dimer.

10. An implant as recited in claim 9, wherein said hydrogel is mixed with an additive selected from the group consisting essentially of chondroitin sulfate and hyaluronic acid.
- 5 11. An implant for repairing an intervertebral disc, comprising:
an inflatable membrane;
said membrane having an internal chamber; and
means for sealing a fill material within said chamber.
- 10 12. An implant as recited in claim 11, wherein said means comprises an internal, self-sealing, fill-valve integral to said membrane.
13. An implant as recited in claim 11, wherein said membrane comprises an elastomer.
- 15 14. An implant as recited in claim 13, wherein said elastomer is biodegradable.
- 15 15. An implant as recited in claim 13, wherein said elastomer comprises
20 polyurethane.
16. An implant as recited in claim 15, wherein said polyurethane comprises aliphatic polycarbonate polyurethane.
- 25 17. An implant as recited in claim 11, wherein said chamber is filled with a hydrogel.
18. An implant as recited in claim 17, wherein said hydrogel comprises cross-linkable polyethylene glycol.
- 30 19. An implant as recited in claim 17, wherein said hydrogel is mixed with an additive selected from the group consisting essentially of chondroitin sulfate and hyaluronic acid.

20. An implant as recited in claim 17, wherein said hydrogel comprises:
a nucleophilic "8-arm" octomer (PEG-NH₂, MW 20 kDa); and
a "2-arm" amine-specific electrophilic dimer.
- 5 21. An implant as recited in claim 20, wherein said hydrogel is mixed with
an additive selected from the group consisting essentially of chondroitin sulfate and
hyaluronic acid.
- 10 22. An implant for repairing an intervertebral disc, comprising:
an inflatable, elastic membrane;
said membrane having an internal chamber;
said membrane having an integral, internal self-sealing fill valve.
- 15 23. An implant as recited in claim 22, wherein said membrane is
biodegradable.
- 25 25. An implant as recited in claim 22, wherein said membrane comprises
polyurethane.
- 20 26. An implant as recited in claim 25, wherein said polyurethane comprises
aliphatic polycarbonate polyurethane.
- 25 27. An implant as recited in claim 22, wherein said chamber is filled with a
hydrogel.
28. An implant as recited in claim 27, wherein said hydrogel comprises
cross-linkable polyethylene glycol.
- 30 29. An implant as recited in claim 27, wherein said hydrogel is mixed with
an additive selected from the group consisting essentially of chondroitin sulfate and
hyaluronic acid.
30. An implant as recited in claim 27, wherein said hydrogel comprises:
a nucleophilic "8-arm" octomer (PEG-NH₂, MW 20 kDa); and

a "2-arm" amine-specific electrophilic dimer.

31. An implant as recited in claim 30, wherein said hydrogel is mixed with an additive selected from the group consisting essentially of chondroitin sulfate and
5 hyaluronic acid.

32. An implant for repairing an intervertebral disc, comprising:
an inflatable, biodegradable, aliphatic polycarbonate polyurethane membrane;
said membrane having an internal chamber;
10 said membrane having an integral, internal self-sealing fill valve.

33. An implant as recited in claim 32, wherein said chamber is filled with a hydrogel.

15 34. An implant as recited in claim 33, wherein said hydrogel comprises cross-linkable polyethylene glycol.

35. An implant as recited in claim 33, wherein said hydrogel is mixed with an additive selected from the group consisting essentially of chondroitin sulfate and
20 hyaluronic acid.

36. An implant as recited in claim 33, wherein said hydrogel comprises:
a nucleophilic "8-arm" octomer (PEG-NH₂, MW 20 kDa); and
a "2-arm" amine-specific electrophilic dimer.
25

37. An implant as recited in claim 36, wherein said hydrogel is mixed with an additive selected from the group consisting essentially of chondroitin sulfate and hyaluronic acid.

30 38. An implant for repairing an intervertebral disc, comprising:
an inflatable, biodegradable, aliphatic polycarbonate polyurethane membrane;
said membrane having an internal chamber filled with a hydrogel;
said membrane having an integral, internal self-sealing fill valve.

39. An implant as recited in claim 38, wherein said hydrogel comprises:
a nucleophilic "8-arm" octomer (PEG-NH₂, MW 20 kDa); and
a "2-arm" amine-specific electrophilic dimer.

5 40. An implant as recited in claim 39, wherein said hydrogel is mixed with
an additive selected from the group consisting essentially of chondroitin sulfate and
hyaluronic acid.

10 41. An implant for repairing an intervertebral disc, comprising:
an inflatable, biodegradable, aliphatic polycarbonate polyurethane membrane;
said membrane having an internal chamber filled with a nucleophilic "8-arm"
octomer (PEG-NH₂, MW 20 kDa) and a "2-arm" amine-specific electrophilic dimer;
said membrane having an integral, internal self-sealing fill valve.

15 42. An implant as recited in claim 41, wherein said material in said
chamber is mixed with an additive selected from the group consisting essentially of
chondroitin sulfate and hyaluronic acid.

20 43. A method for repairing an intervertebral disc, comprising:
inserting an inflatable implant into a nuclear space within an intervertebral
disk; and
inflating said implant with a hydrogel.

25 44. A method as recited in claim 43, wherein said implant comprises:
an inflatable membrane;
said membrane having an internal chamber;
said membrane having an integral, internal self-sealing fill valve.

30 45. A method as recited in claim 44, wherein said membrane comprises an
elastomer.

 46. A method as recited in claim 45, wherein said elastomer is
biodegradable.

47. A method as recited in claim 45, wherein said elastomer comprises polyurethane.

48. A method as recited in claim 47, wherein said polyurethane comprises
5 aliphatic polycarbonate polyurethane.

49. A method as recited in claim 43, wherein said hydrogel comprises cross-linkable polyethylene glycol.

10 50. A method as recited in claim 43, wherein said hydrogel is mixed with an additive selected from the group consisting essentially of chondroitin sulfate and hyaluronic acid.

51. A method as recited in claim 43, wherein said hydrogel comprises:
15 a nucleophilic "8-arm" octomer (PEG-NH₂, MW 20 kDa); and
a "2-arm" amine-specific electrophilic dimer.

52. A method as recited in claim 51, wherein said hydrogel is mixed with an additive selected from the group consisting essentially of chondroitin sulfate and
20 hyaluronic acid.

53. A method as recited in claim 43, further comprising removing nucleus pulposus tissue to form said nuclear space.

25 54. A method as recited in claim 53, further comprising removing said nucleus pulposus tissue by performing a postero-lateral percutaneous discectomy.

55. A method for repairing an intervertebral disc, comprising:
inserting an inflatable implant into a nuclear space within an intervertebral

30 disk;

wherein said inflatable implant comprises,

an inflatable membrane,

said membrane having an internal chamber,

said membrane having an integral, internal self-sealing fill valve; and

inflating said implant with a hydrogel.

56. A method as recited in claim 55, wherein said membrane comprises an elastomer.

5

57. A method as recited in claim 56, wherein said elastomer is biodegradable.

58. A method as recited in claim 56, wherein said elastomer comprises polyurethane.

10

59. A method as recited in claim 58, wherein said polyurethane comprises aliphatic polycarbonate polyurethane.

60. A method as recited in claim 55, wherein said hydrogel comprises cross-linkable polyethylene glycol.

15

61. A method as recited in claim 55, wherein said hydrogel is mixed with an additive selected from the group consisting essentially of chondroitin sulfate and hyaluronic acid.

20

62. A method as recited in claim 55, wherein said hydrogel comprises: a nucleophilic "8-arm" octomer (PEG-NH₂, MW 20 kDa); and a "2-arm" amine-specific electrophilic dimer.

25

63. A method as recited in claim 62, wherein said hydrogel is mixed with an additive selected from the group consisting essentially of chondroitin sulfate and hyaluronic acid.

64. A method as recited in claim 55, further comprising removing nucleus pulposus tissue to form said nuclear space.

30

65. A method as recited in claim 64, further comprising removing said nucleus pulposus tissue by performing a postero-lateral percutaneous discectomy.

66. A method for repairing an intervertebral disc, comprising:
inserting an inflatable implant into a nuclear space within an intervertebral
disc; and
5 inflating said implant with cross-linkable polyethylene glycol.

67. A method as recited in claim 66, wherein said cross-linkable
polyethylene glycol is mixed with an additive selected from the group consisting
essentially of chondroitin sulfate and hyaluronic acid.

68. A method as recited in claim 66, wherein said cross-linkable
polyethylene glycol comprises:
a nucleophilic "8-arm" octomer (PEG-NH₂, MW 20 kDa); and
a "2-arm" amine-specific electrophilic dimer.

69. A method as recited in claim 66, wherein said implant comprises:
an inflatable membrane;
said membrane having an internal chamber;
said membrane having an integral, internal self-sealing fill valve.

70. A method as recited in claim 69, wherein said membrane comprises an
elastomer.

71. A method as recited in claim 70, wherein said elastomer is
25 biodegradable.

72. A method as recited in claim 70, wherein said elastomer comprises
polyurethane.

73. A method as recited in claim 72, wherein said polyurethane comprises
30 aliphatic polycarbonate polyurethane.

74. A method as recited in claim 66, further comprising removing nucleus
pulposus tissue to form said nuclear space.

75. A method as recited in claim 74, further comprising removing said nucleus pulposus tissue by performing a postero-lateral percutaneous discectomy.

5 76. A method for repairing an intervertebral disc, comprising:
inserting an inflatable implant into a nuclear space within an intervertebral
disc;
wherein said inflatable implant comprises,
an inflatable membrane,
10 said membrane having an internal chamber,
said membrane having an integral, internal self-sealing fill valve; and
inflating said implant with cross-linkable polyethylene glycol.

77. A method as recited in claim 76, wherein said cross-linkable
15 polyethylene glycol is mixed with an additive selected from the group consisting
essentially of chondroitin sulfate and hyaluronic acid.

78. A method as recited in claim 76, wherein said cross-linkable
polyethylene glycol comprises:
20 a nucleophilic "8-arm" octomer (PEG-NH₂, MW 20 kDa); and
a "2-arm" amine-specific electrophilic dimer.

79. A method as recited in claim 76, wherein said membrane comprises an
elastomer.

25 80. A method as recited in claim 79, wherein said elastomer is
biodegradable.

81. A method as recited in claim 79, wherein said elastomer comprises
30 polyurethane.

82. A method as recited in claim 81, wherein said polyurethane comprises
aliphatic polycarbonate polyurethane.

83. A method as recited in claim 76, further comprising removing nucleus pulposus tissue to form said nuclear space.

84. A method as recited in claim 83, further comprising removing said
5 nucleus pulposus tissue by performing a postero-lateral percutaneous discectomy.

85. A method for repairing an intervertebral disc, comprising:
inserting an inflatable implant into a nuclear space within an intervertebral
disc;
10 wherein said inflatable implant comprises,
an inflatable, aliphatic polycarbonate polyurethane membrane,
said membrane having an internal chamber,
said membrane having an integral, internal self-sealing fill valve; and
inflating said implant with a mixture of cross-linkable polyethylene glycol and
15 an additive selected from the group consisting essentially of chondroitin sulfate and
hyaluronic acid.

86. A method as recited in claim 85, wherein said cross-linkable
polyethylene glycol comprises:
20 a nucleophilic "8-arm" octomer (PEG-NH₂, MW 20 kDa); and
a "2-arm" amine-specific electrophilic dimer.

87. A method as recited in claim 85, further comprising removing nucleus
pulposus tissue to form said nuclear space.

25 88. A method as recited in claim 87, further comprising removing said
nucleus pulposus tissue by performing a postero-lateral percutaneous discectomy.

89. An implant system for repairing an intervertebral disc, comprising:
30 an inflatable membrane;
said membrane having an internal chamber;
said membrane having an integral, internal self-sealing fill valve;
said membrane configured for insertion into a nuclear space created by
removing nucleus pulposus tissue in an intervertebral disc; and

an annular buttress configured for placement in the annulus fibrosus of said intervertebral disc and retention of said membrane in said nuclear space.

90. An implant system as recited in claim 89, wherein said buttress
5 includes a plurality of pins configured for engaging said annulus fibrosus.

91. An implant system as recited in claim 89, wherein said membrane
comprises an elastomer.

10 92. An implant system as recited in claim 91, wherein said elastomer is
biodegradable.

93. An implant system as recited in claim 91, wherein said elastomer
comprises polyurethane.

15

94. An implant system as recited in claim 93, wherein said polyurethane
comprises aliphatic polycarbonate polyurethane.

95. An implant system as recited in claim 89, wherein said chamber is filled
20 with a hydrogel.

96. An implant system as recited in claim 95, wherein said hydrogel
comprises cross-linkable polyethylene glycol.

25 97. An implant system as recited in claim 95, wherein said hydrogel is
mixed with an additive selected from the group consisting essentially of chondroitin
sulfate and hyaluronic acid.

98. An implant system as recited in claim 95, wherein said hydrogel
30 comprises:

a nucleophilic "8-arm" octomer (PEG-NH₂, MW 20 kDa); and
a "2-arm" amine-specific electrophilic dimer.

99. An implant system as recited in claim 98, wherein said hydrogel is mixed with an additive selected from the group consisting essentially of chondroitin sulfate and hyaluronic acid.

5 100. An implant system for repairing an intervertebral disc, comprising:
an inflatable membrane;
said membrane having an internal chamber;
means for sealing a fill material within said chamber;
said membrane configured for insertion into a nuclear space created by
10 removing nucleus pulposus tissue in an intervertebral disc; and
an annular buttress configured for placement in the annulus fibrosus of said intervertebral disc and retention of said membrane in said nuclear space.

101. An implant system as recited in claim 100, wherein said buttress
15 includes a plurality of pins configured for engaging said annulus fibrosus.

102. An implant system as recited in claim 100, wherein said means comprises an internal, self-sealing, fill-valve integral to said membrane.

20 103. An implant system as recited in claim 100, wherein said membrane comprises an elastomer.

104. An implant system as recited in claim 103, wherein said elastomer is biodegradable.
25

105. An implant system as recited in claim 103, wherein said elastomer comprises polyurethane.

106. An implant system as recited in claim 105, wherein said polyurethane
30 comprises aliphatic polycarbonate polyurethane.

107. An implant system as recited in claim 100, wherein said chamber is filled with a hydrogel.

108. An implant system as recited in claim 107, wherein said hydrogel comprises cross-linkable polyethylene glycol.

5 109. An implant system as recited in claim 107, wherein said hydrogel is mixed with an additive selected from the group consisting essentially of chondroitin sulfate and hyaluronic acid.

110. An implant system as recited in claim 107, wherein said hydrogel comprises:
10 a nucleophilic "8-arm" octomer (PEG-NH₂, MW 20 kDa); and
a "2-arm" amine-specific electrophilic dimer.

111. An implant system as recited in claim 110, wherein said hydrogel is mixed with an additive selected from the group consisting essentially of chondroitin
15 sulfate and hyaluronic acid.

112. An implant system for repairing an intervertebral disc, comprising:
an inflatable, elastic membrane;
said membrane having an internal chamber;
20 said membrane having an integral, internal self-sealing fill valve;
said membrane configured for insertion into a nuclear space created by removing nucleus pulposus tissue in an intervertebral disc; and
an annular buttress configured for placement in the annulus fibrosus of said
intervertebral disc and retention of said membrane in said nuclear space.

25 113. An implant system as recited in claim 112, wherein said buttress includes a plurality of pins configured for engaging said annulus fibrosus.

114. An implant system as recited in claim 112, wherein said membrane is
30 biodegradable.

115. An implant system as recited in claim 112, wherein said membrane comprises polyurethane.

116. An implant system as recited in claim 115, wherein said polyurethane comprises aliphatic polycarbonate polyurethane.

117. An implant system as recited in claim 112, wherein said chamber is
5 filled with a hydrogel.

118. An implant system as recited in claim 117, wherein said hydrogel comprises cross-linkable polyethylene glycol.

10 119. An implant system as recited in claim 117, wherein said hydrogel is mixed with an additive selected from the group consisting essentially of chondroitin sulfate and hyaluronic acid.

120. An implant system as recited in claim 117, wherein said hydrogel
15 comprises:

a nucleophilic "8-arm" octomer (PEG-NH₂, MW 20 kDa); and
a "2-arm" amine-specific electrophilic dimer.

121. An implant system as recited in claim 120, wherein said hydrogel is
20 mixed with an additive selected from the group consisting essentially of chondroitin sulfate and hyaluronic acid.

122. An implant system for repairing an intervertebral disc, comprising:
an inflatable, biodegradable, aliphatic polycarbonate polyurethane membrane;
25 said membrane having an internal chamber;
said membrane having an integral, internal self-sealing fill valve;
said membrane configured for insertion into a nuclear space created by removing nucleus pulposus tissue in an intervertebral disc; and
an annular buttress configured for placement in the annulus fibrosus of said
30 intervertebral disc and retention of said membrane in said nuclear space.

123. An implant system as recited in claim 122, wherein said buttress includes a plurality of pins configured for engaging said annulus fibrosus.

124. An implant system as recited in claim 122, wherein said chamber is filled with a hydrogel.

125. An implant system as recited in claim 124, wherein said hydrogel
5 comprises cross-linkable polyethylene glycol.

126. An implant system as recited in claim 124, wherein said hydrogel is mixed with an additive selected from the group consisting essentially of chondroitin sulfate and hyaluronic acid.
10

127. An implant system as recited in claim 124, wherein said hydrogel comprises:

a nucleophilic "8-arm" octomer (PEG-NH₂, MW 20 kDa); and
a "2-arm" amine-specific electrophilic dimer.

15

128. An implant system as recited in claim 127, wherein said hydrogel is mixed with an additive selected from the group consisting essentially of chondroitin sulfate and hyaluronic acid.

129. An implant system for repairing an intervertebral disc, comprising:
an inflatable, biodegradable, aliphatic polycarbonate polyurethane membrane;
said membrane having an internal chamber filled with a hydrogel;
said membrane having an integral, internal self-sealing fill valve;
said membrane configured for insertion into a nuclear space created by
20 removing nucleus pulposus tissue in an intervertebral disc; and
an annular buttress configured for placement in the annulus fibrosus of said intervertebral disc and retention of said membrane in said nuclear space.

130. An implant system as recited in claim 129, wherein said buttress
30 includes a plurality of pins configured for engaging said annulus fibrosus.

131. An implant system as recited in claim 129, wherein said hydrogel comprises:

a nucleophilic "8-arm" octomer (PEG-NH₂, MW 20 kDa); and

a "2-arm" amine-specific electrophilic dimer.

132. An implant system as recited in claim 131, wherein said hydrogel is mixed with an additive selected from the group consisting essentially of chondroitin sulfate and hyaluronic acid.

133. An implant system for repairing an intervertebral disc, comprising:
an inflatable, biodegradable, aliphatic polycarbonate polyurethane membrane;
said membrane having an internal chamber filled with a nucleophilic "8-arm"
octomer (PEG-NH₂, MW 20 kDa) and a "2-arm" amine-specific electrophilic dimer;
said membrane having an integral, internal self-sealing fill valve;
said membrane configured for insertion into a nuclear space created by removing nucleus pulposus tissue in an intervertebral disc; and
an annular buttress configured for placement in the annulus fibrosus of said intervertebral disc and retention of said membrane in said nuclear space..

134. An implant system as recited in claim 133, wherein said buttress includes a plurality of pins configured for engaging said annulus fibrosus.

135. An implant system as recited in claim 133, wherein said material in said chamber is mixed with an additive selected from the group consisting essentially of chondroitin sulfate and hyaluronic acid.

136. An apparatus for sealing a nuclear space after removal of nucleus pulposus tissue in a intervertebral disc, comprising:
an annular buttress;
said buttress configured for placement in the annulus fibrosus of said intervertebral disc;
said buttress including a plurality of pins configured for engaging said annulus fibrosus.

137. An apparatus as recited in claim 136, wherein said buttress comprises:
an annular head portion; and
a body portion extending from said head portion;

said pins extending from said head portion and along said body portion.

138. An apparatus as recited in claim 137, further comprising an opening extending through said head portion and said body portion.

5

139. An apparatus as recited in claim 138, further comprising threads in at least a portion of said opening.

140. An apparatus as recited in claim 137, wherein said pins have ends
10 extending outward in relation to said body portion.

141. An apparatus as recited in claim 140, wherein said body portion has a diameter smaller than the diameter of said head portion.

15 142. An apparatus for sealing a nuclear space after removal of nucleus pulposus tissue in a intervertebral disc, comprising:

an annular buttress;

said buttress configured for placement in the annulus fibrosus of said intervertebral disc; and

20 means for engaging coupling said buttress to said annulus fibrosus.

143. An apparatus as recited in claim 142, wherein said means comprises a plurality of pins attached to said buttress.

25 144. An apparatus as recited in claim 143, wherein said buttress comprises:

an annular head portion; and

a body portion extending from said head portion;

said pins extending from said head portion and along said body portion.

30 145. An apparatus as recited in claim 144, further comprising an opening extending through said head portion and said body portion.

146. An apparatus as recited in claim 145, further comprising threads in at least a portion of said opening.

147. An apparatus as recited in claim 144, wherein said pins having ends extending outward in relation to said body portion.

5 148. An apparatus as recited in claim 147, wherein said body portion has a diameter smaller than the diameter of said head portion.

149. An apparatus for sealing a nuclear space after removal of nucleus pulposus tissue in a intervertebral disc, comprising:
10 an annular buttress;
said buttress having a head portion;
said buttress having a body portion extending from said head portion; and
a plurality of pins extending from said head portion and along said body portion.

15 150. An apparatus as recited in claim 149, further comprising an opening extending through said head portion and said body portion.

20 151. An apparatus as recited in claim 150, further comprising threads in at least a portion of said opening.

152. An apparatus as recited in claim 149, wherein said pins have ends extending outward in relation to said body portion.

25 153. An apparatus as recited in claim 152, wherein said body portion has a diameter smaller than the diameter of said head portion.

154. An apparatus for sealing a nuclear space after removal of nucleus pulposus tissue in a intervertebral disc, comprising:
30 an annular buttress;
said buttress having a head portion;
said buttress having a body portion extending from said head portion;
said body portion having a diameter smaller than the diameter of said head portion; and

a plurality of pins extending from said head portion and along said body portion;

said pins having ends extending outward in relation to said body portion.

5 155. An apparatus as recited in claim 154, further comprising an opening extending through said head portion and said body portion.

156. An apparatus as recited in claim 155, further comprising threads in at least a portion of said opening.

10

157. A method of fabricating an implant for repairing an intervertebral disc, comprising:

coating a mandrel with a membrane material;

drying said membrane material;

15 drawing said membrane material off of said mandrel by rolling said membrane material toward an end of said mandrel; and

sealing an end of said membrane material.

20 158. A method as recited in claim 157, wherein said mandrel comprises: a stem portion;

a first cylindrical base portion extending from said stem portion;

a mold portion extending from said first cylindrical base portion;

a second cylindrical base portion extending from said mold portion; and

a shank extending from said second cylindrical base portion.

25

159. A method as recited in claim 158, further comprising:

dipping said stem portion, said first cylindrical based portion, and said mold portion in a bath of said membrane material to a defined depth.

30 160. A method as recited in claim 159, wherein said defined depth is generally at a point along said second base portion.

161. A method as recited in claim 157, further comprising molding said membrane to a thickness between approximately 5 mils and 7 mils.

162. A method as recited in claim 158, wherein rolling said membrane off said mandrel turns said membrane inside-out.

163. A method as recited in claim 162, wherein the portion of membrane material that coated said stem portion become a self-sealing valve interior to said implant.

164. A method as recited in claim 162, wherein the portion of said membrane material that coated said first base portion becomes an entrance port into said self-sealing valve.

165. A method of fabricating an implant for repairing an intervertebral disc, comprising:
coating a mandrel with a membrane material to a thickness between approximately 5 mils and approximately 7 mils;
drying said membrane material;
drawing said membrane material off of said mandrel by rolling said membrane material toward an end of said mandrel; and
sealing an end of said membrane material.

166. A method as recited in claim 165, wherein said mandrel comprises:
a stem portion;
a first cylindrical base portion extending from said stem portion;
a mold portion extending from said first cylindrical base portion;
a second cylindrical base portion extending from said mold portion; and
a shank extending from said second cylindrical base portion.

167. A method as recited in claim 166, further comprising:
dipping said stem portion, said first cylindrical based portion, and said mold portion in a bath of said membrane material to a defined depth.

168. A method as recited in claim 167, wherein said defined depth is generally at a point along said second base portion.

169. A method as recited in claim 166, wherein rolling said membrane off said mandrel turns said membrane inside-out.

170. A method as recited in claim 169, wherein the portion of membrane material that coated said stem portion become a self-sealing valve interior to said implant.

171. A method as recited in claim 169, wherein the portion of said membrane material that coated said first base portion becomes an entrance port into said self-sealing valve.

172. A method of fabricating an implant for repairing an intervertebral disc, comprising:

coating a mandrel with a membrane material to a thickness between approximately 5 mils and approximately 7 mils;
drying said membrane material;
drawing said membrane material off of said mandrel by rolling said membrane material toward an end of said mandrel; and
sealing an end of said membrane material;
wherein said mandrel comprises,
a stem portion,
a first cylindrical base portion extending from said stem portion,
a mold portion extending from said first cylindrical base portion,
a second cylindrical base portion extending from said mold portion, and
a shank extending from said second cylindrical base portion.

173. A method as recited in claim 172, further comprising:
dipping said stem portion, said first cylindrical based portion, and said mold portion in a bath of said membrane material to a defined depth.

174. A method as recited in claim 173, wherein said defined depth is generally at a point along said second base portion.

175. A method as recited in claim 172, wherein rolling said membrane off said mandrel turns said membrane inside-out.

176. A method as recited in claim 175, wherein the portion of membrane
5 material that coated said stem portion become a self-sealing valve interior to said implant.

177. A method as recited in claim 175, wherein the portion of said
membrane material that coated said first base portion becomes an entrance port into
10 said self-sealing valve.

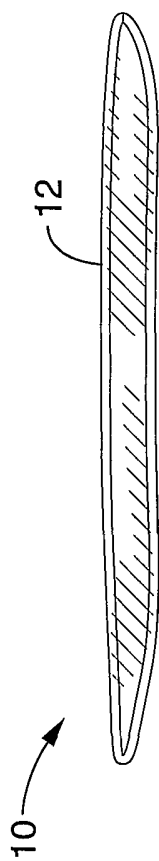

FIG. 1

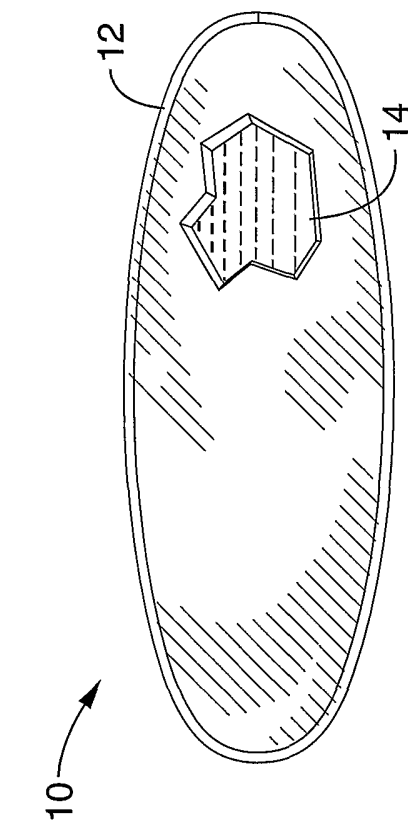

FIG. 2

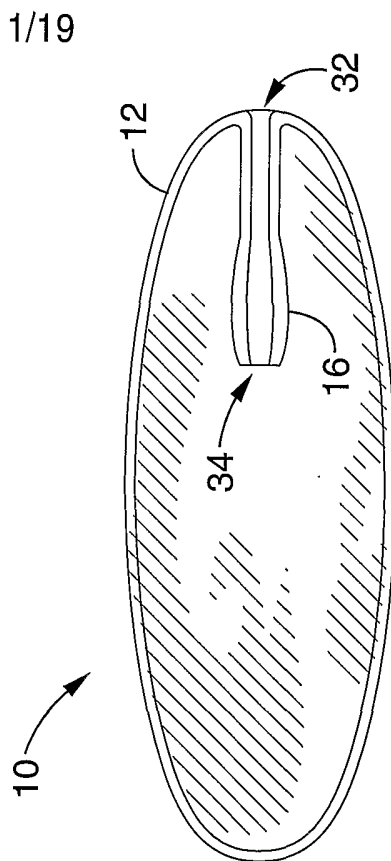

FIG. 3

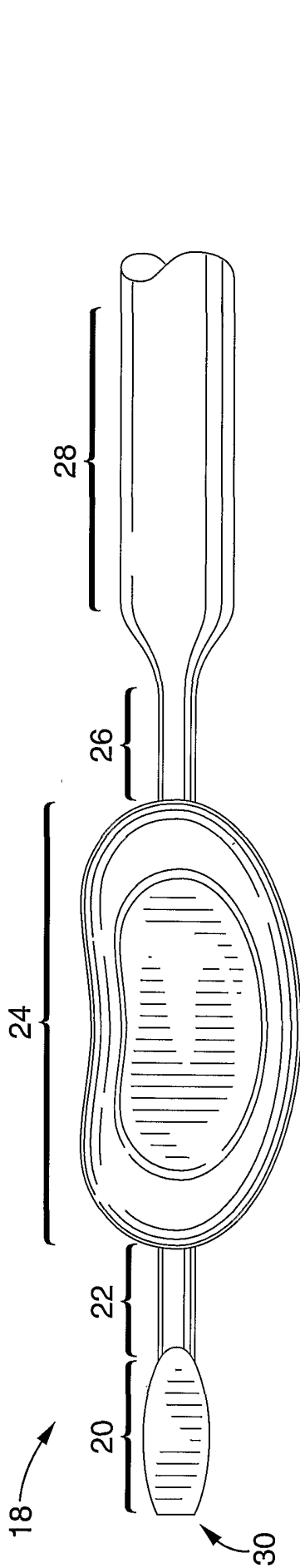

FIG. 4

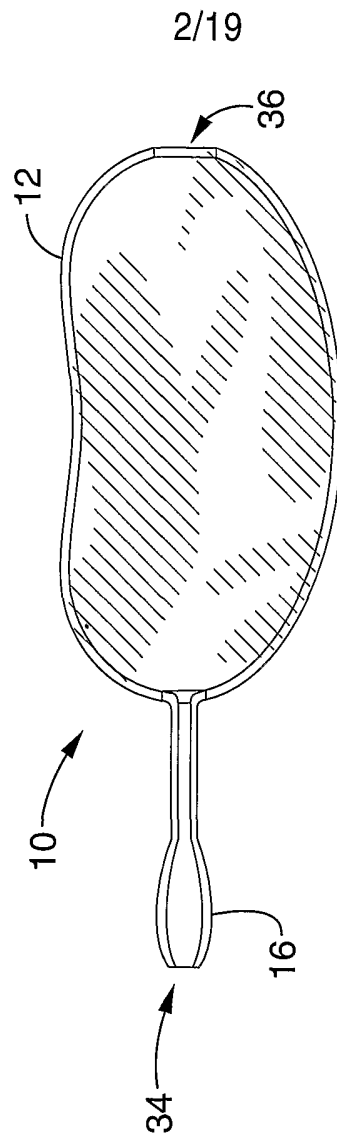

FIG. 5

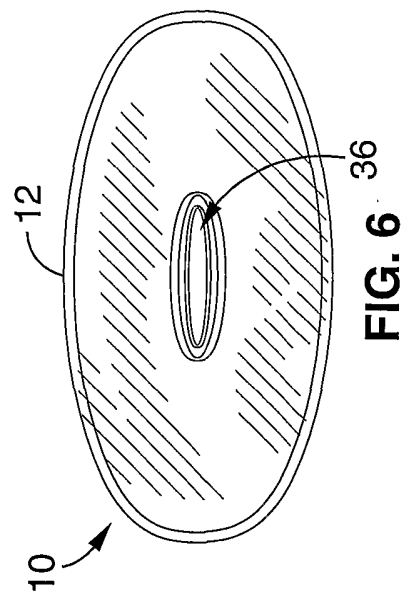

FIG. 6

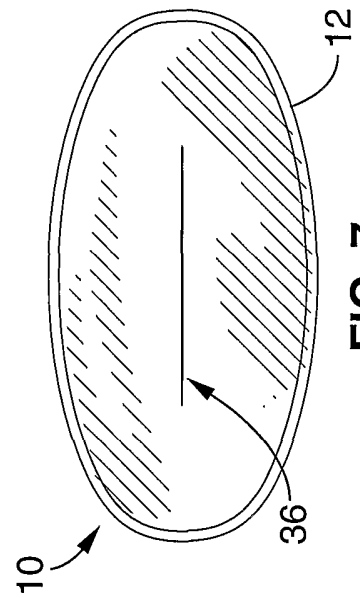

FIG. 7

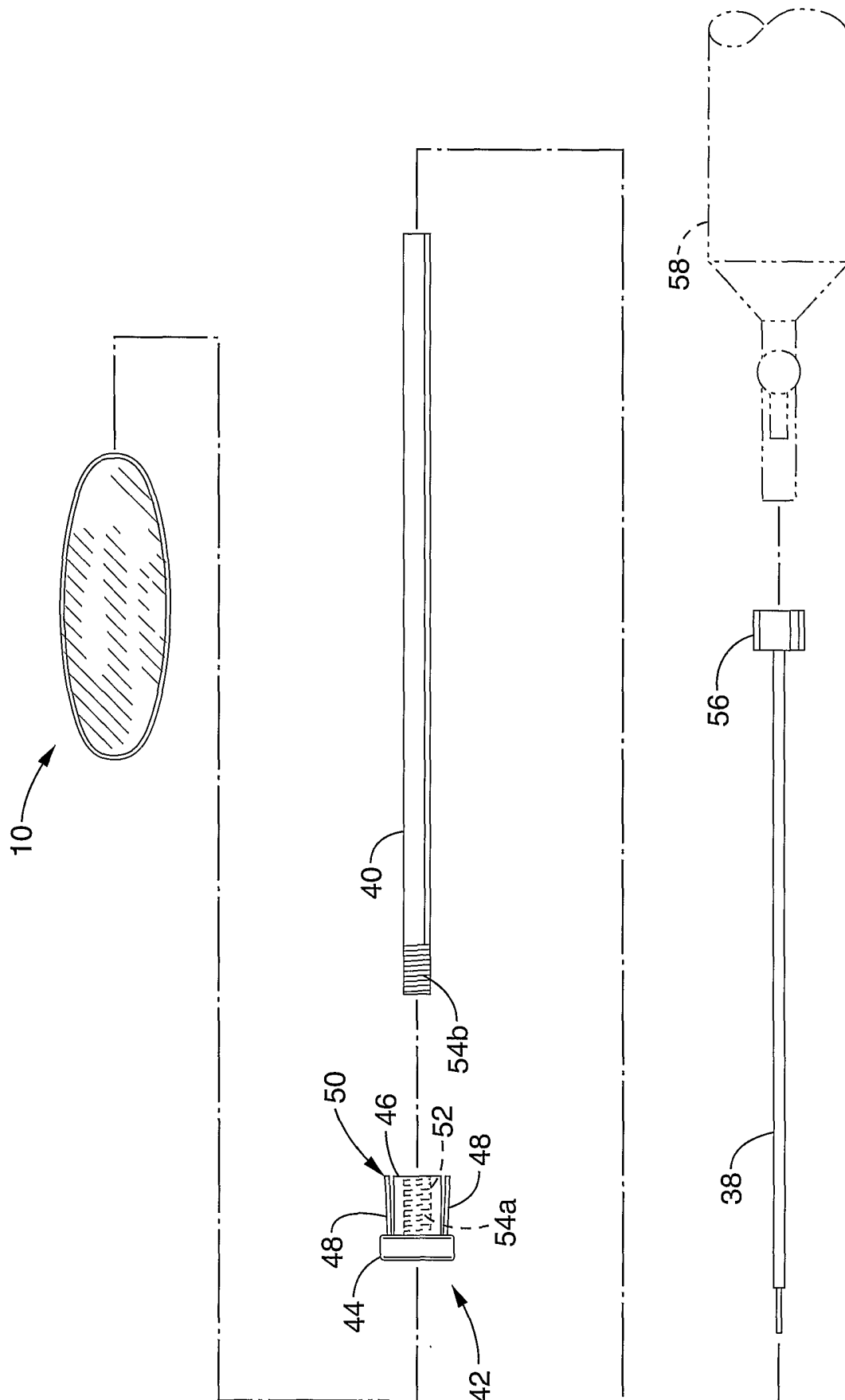

FIG. 8

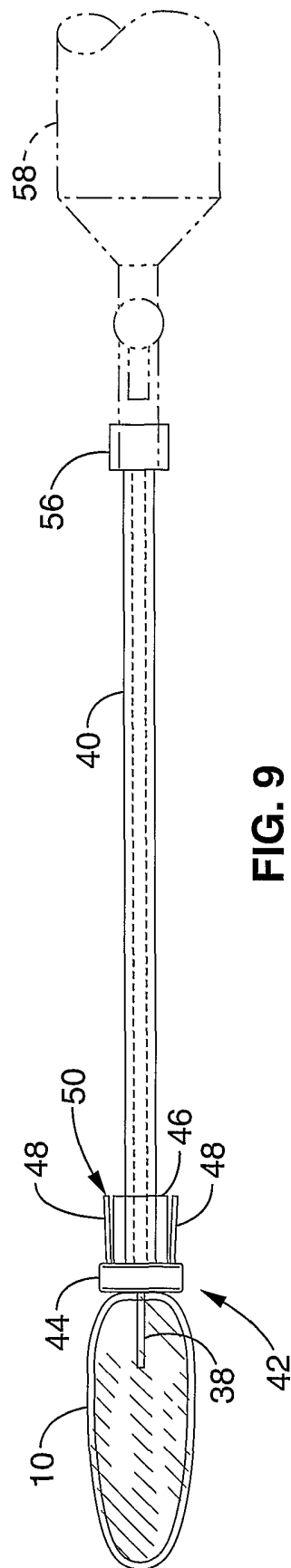

FIG. 9

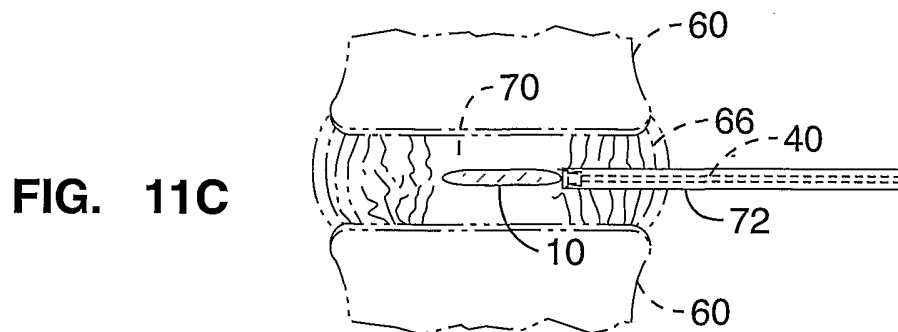
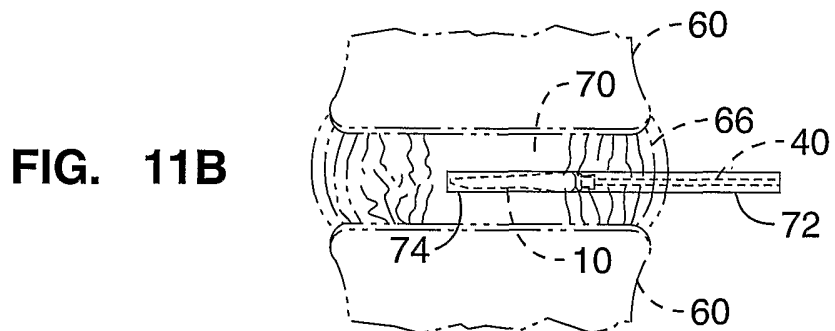
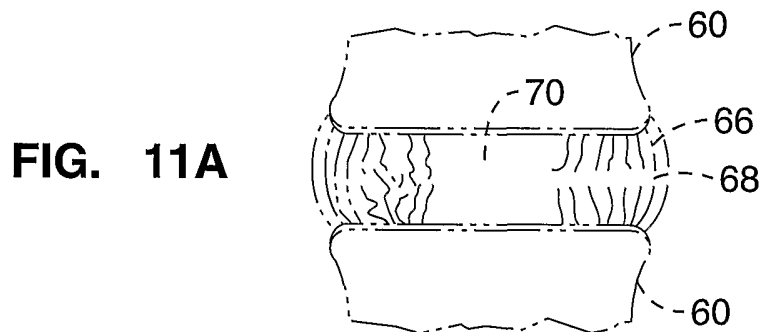
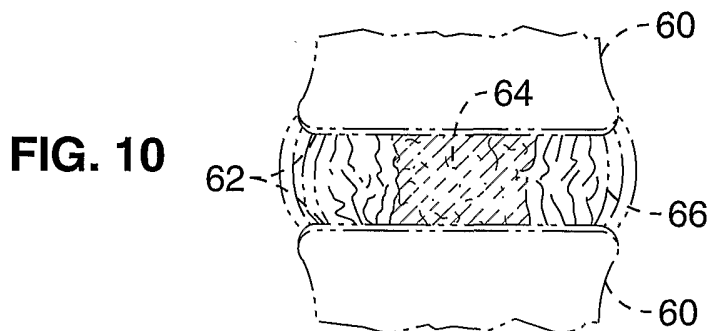

FIG. 11D

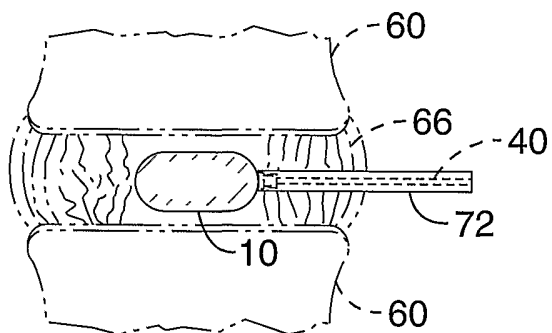

FIG. 11E

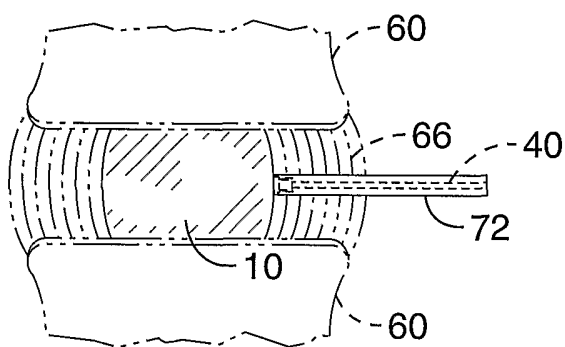

FIG. 11F

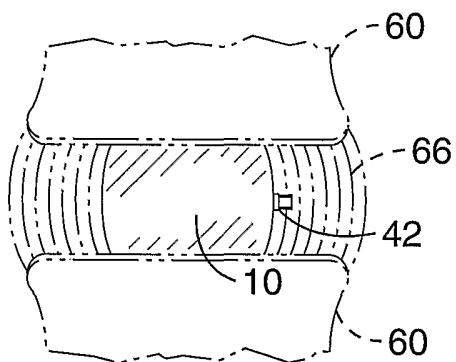
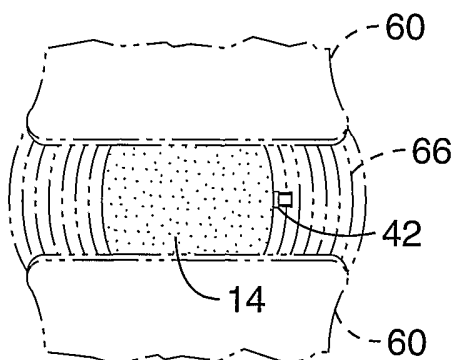

FIG. 11G



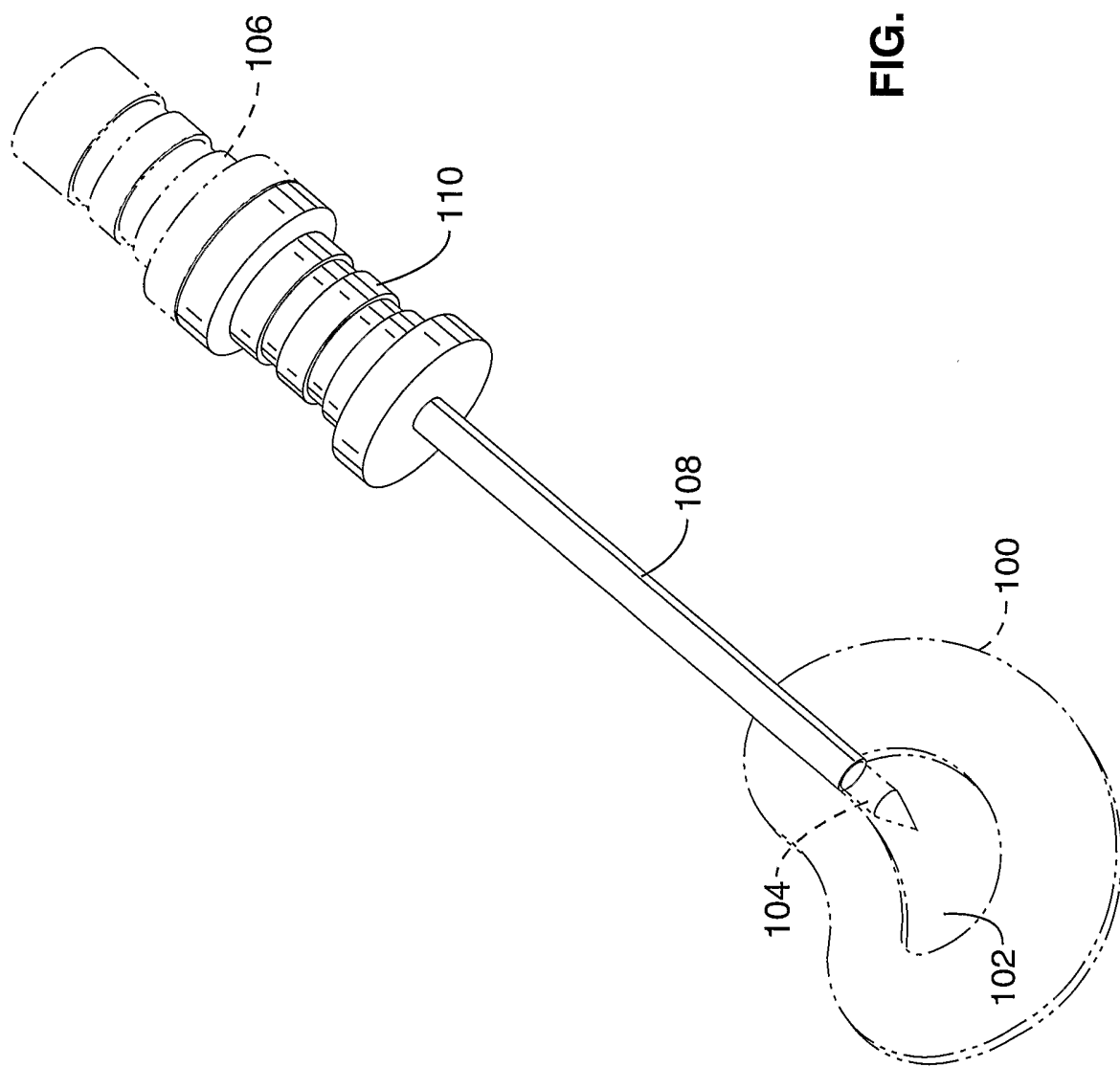
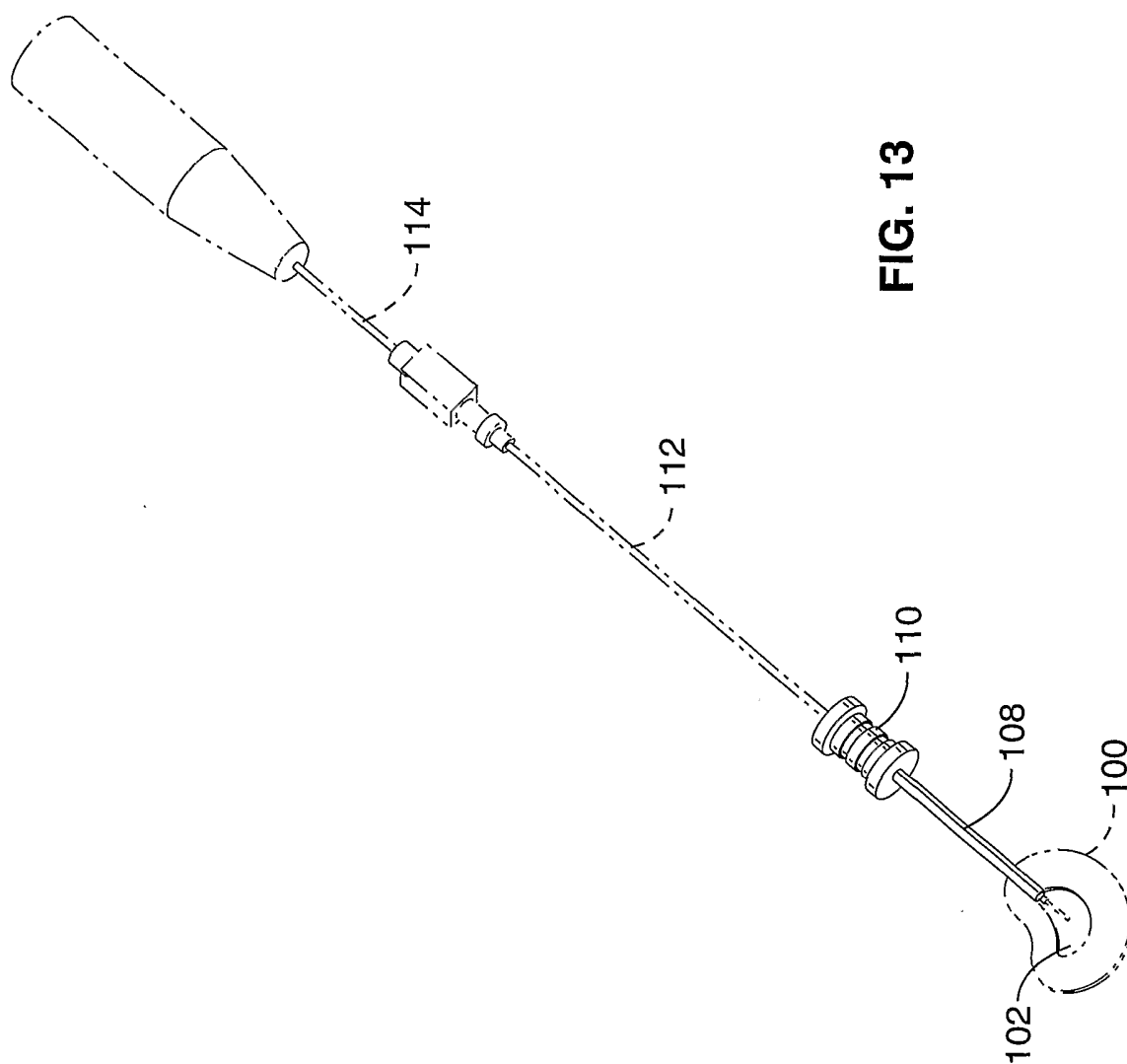

FIG. 12



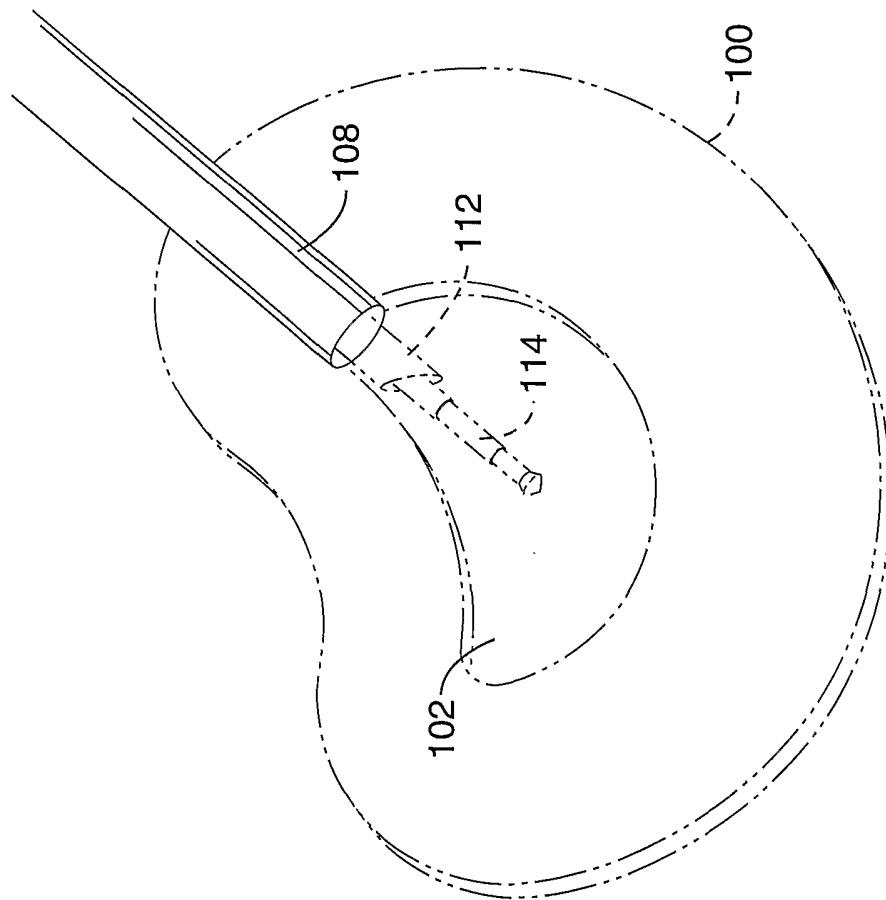

FIG. 14

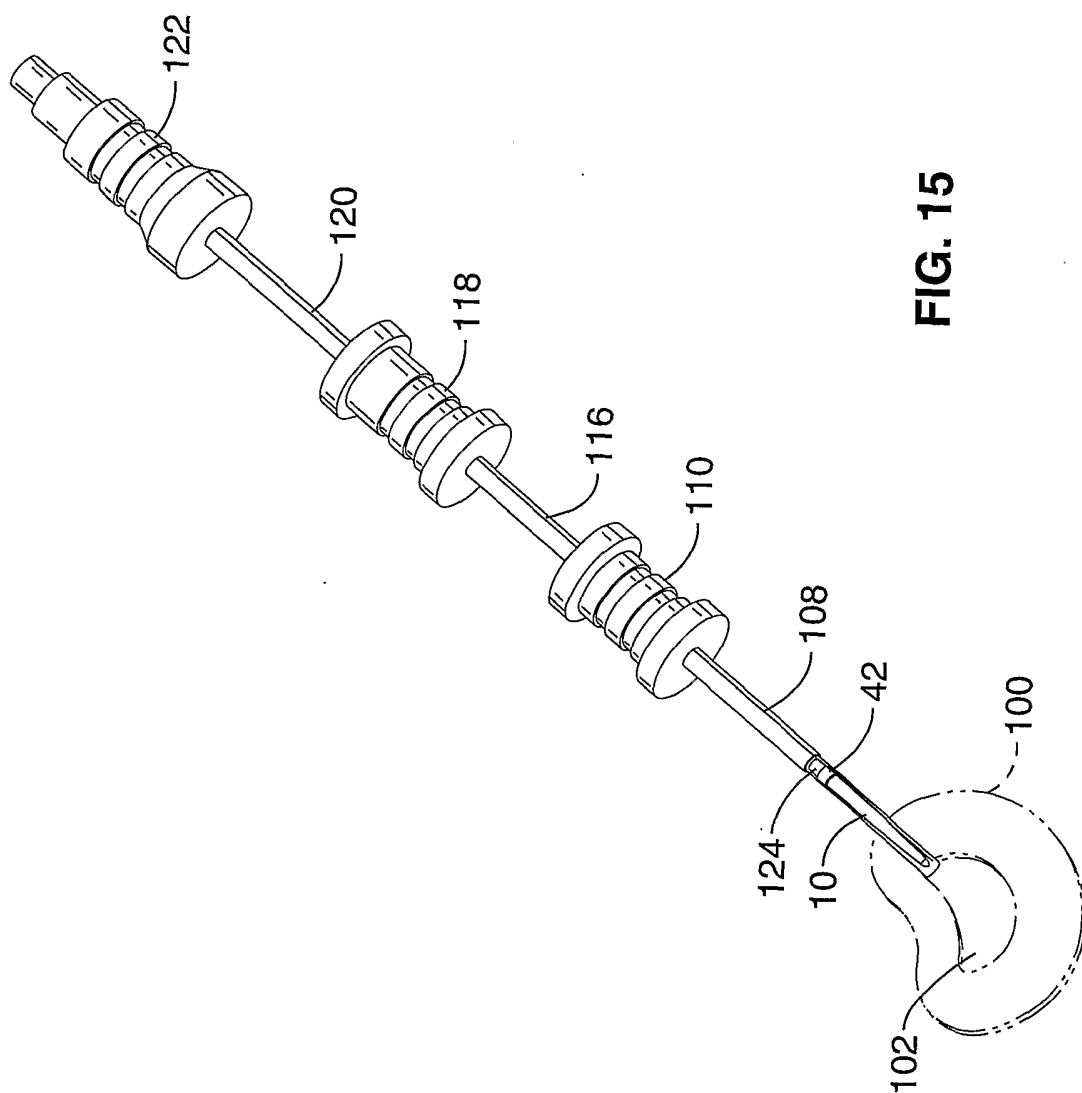

FIG. 15

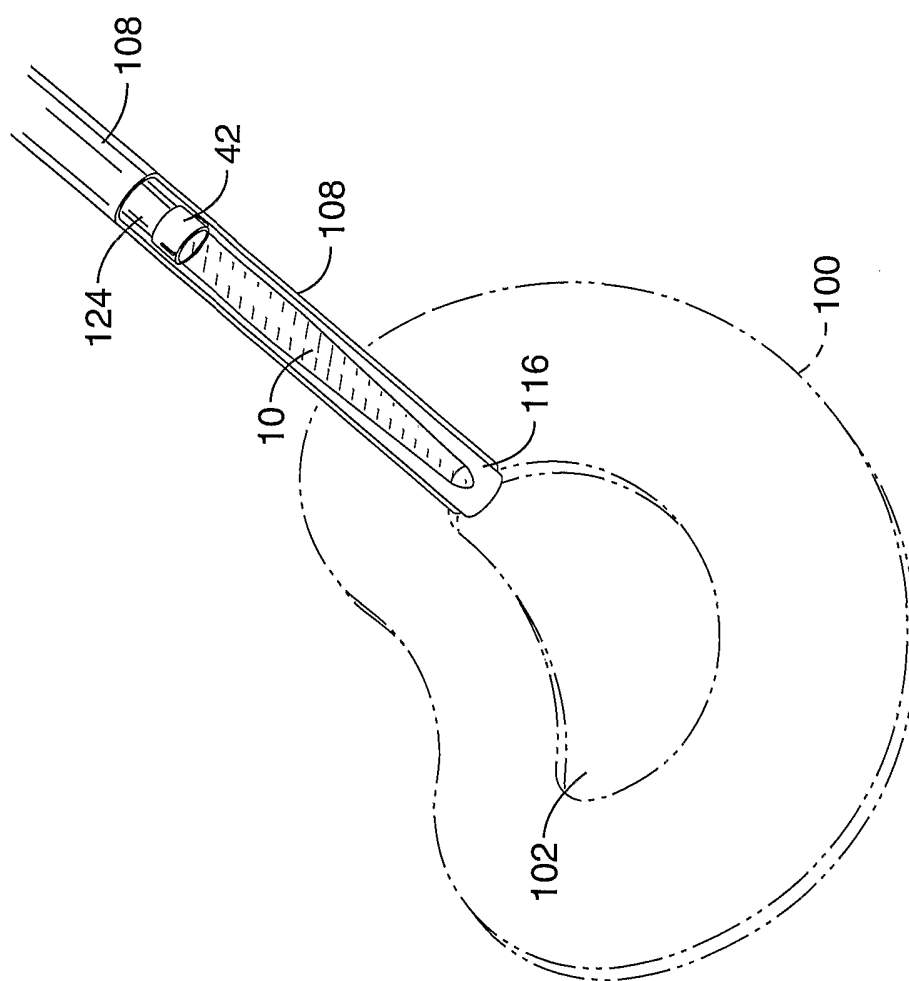

FIG. 16

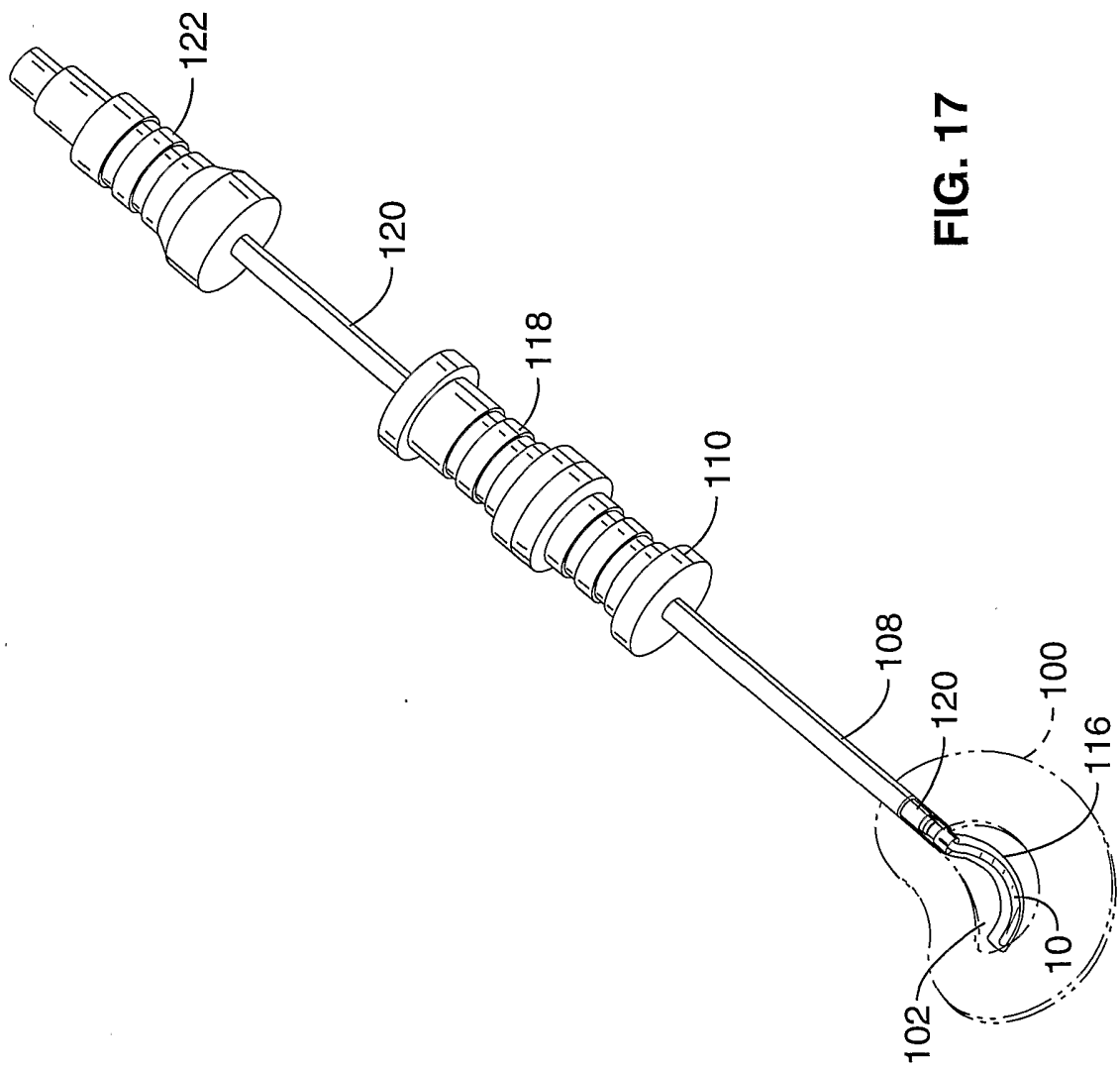

FIG. 17

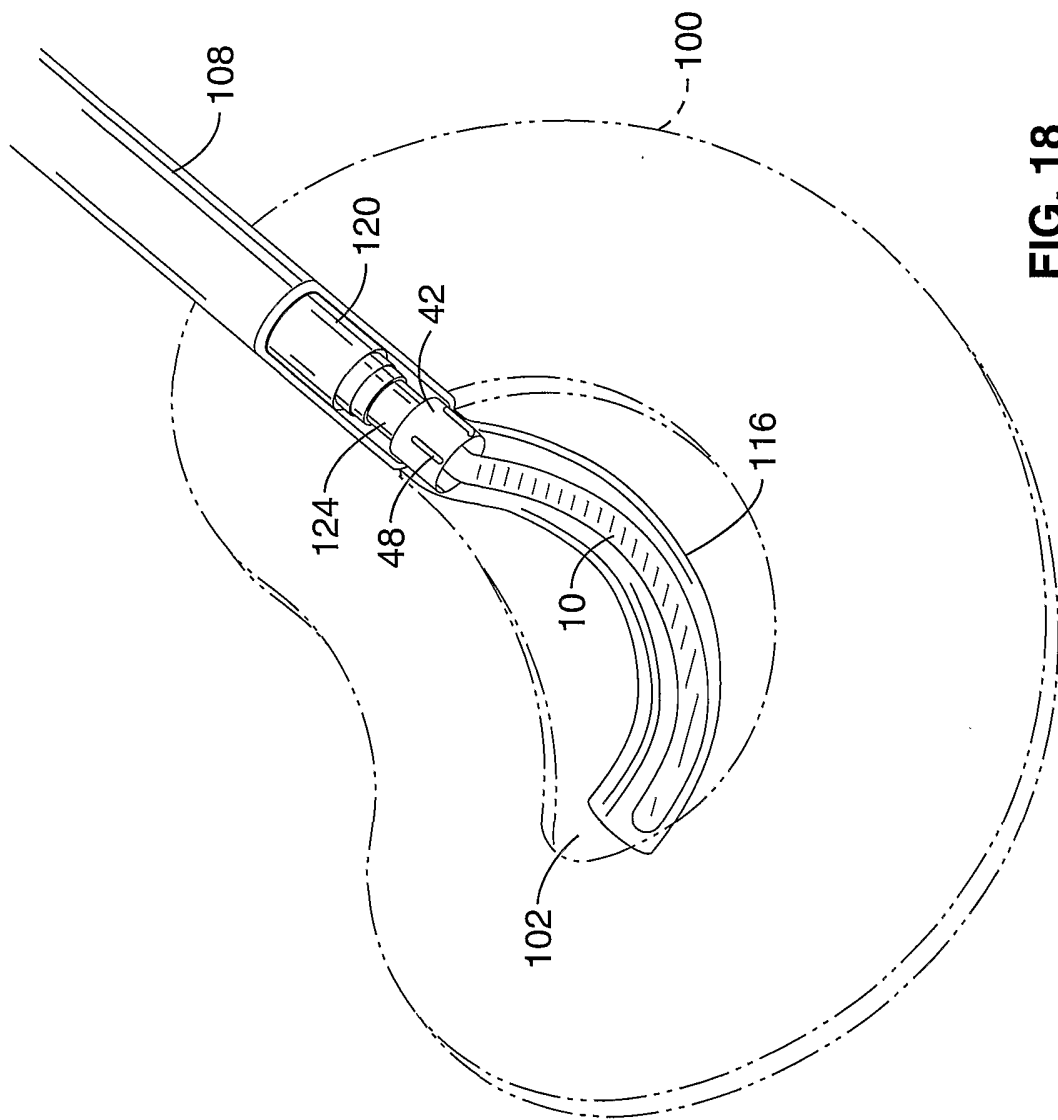

FIG. 18

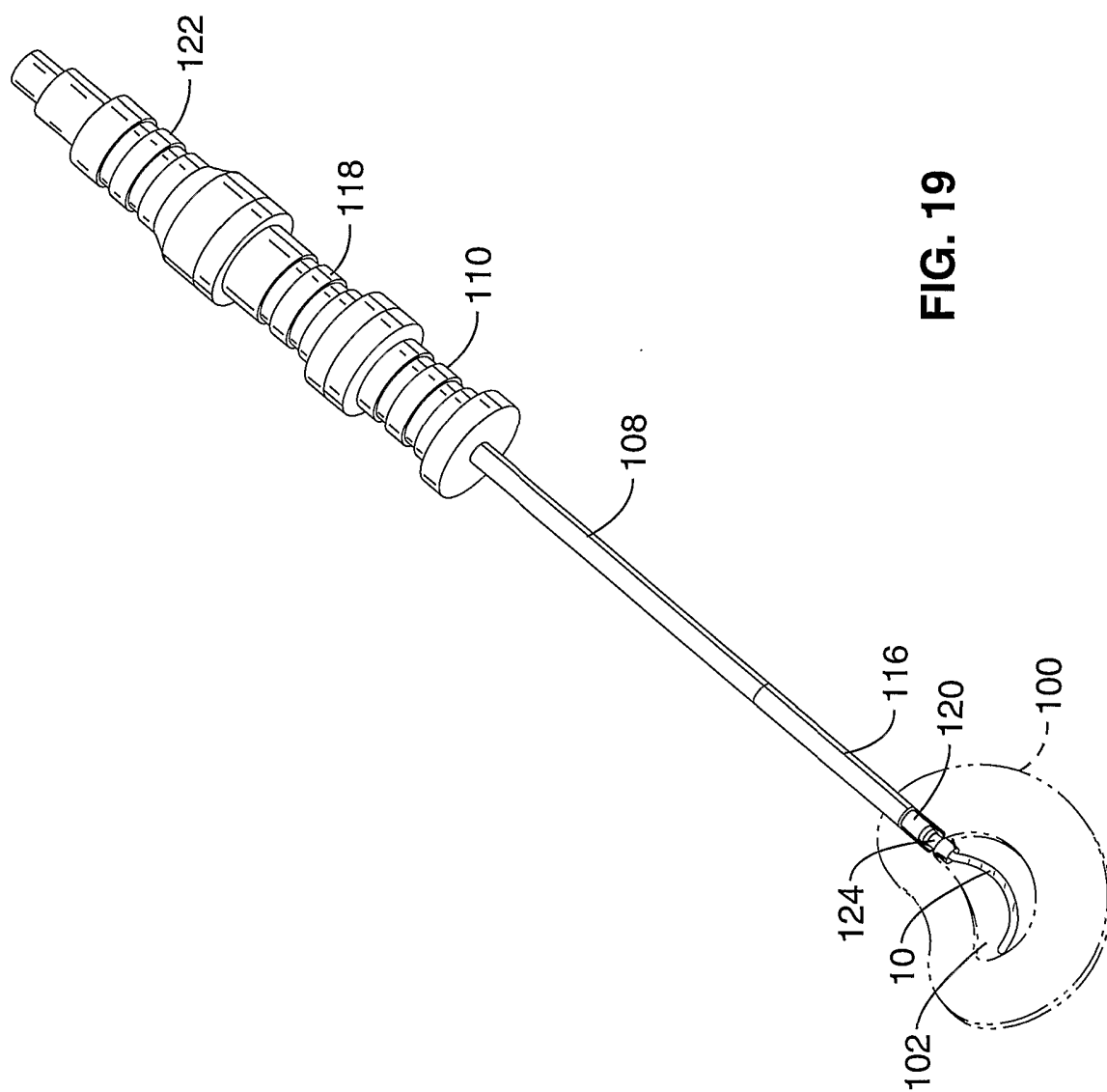

FIG. 19

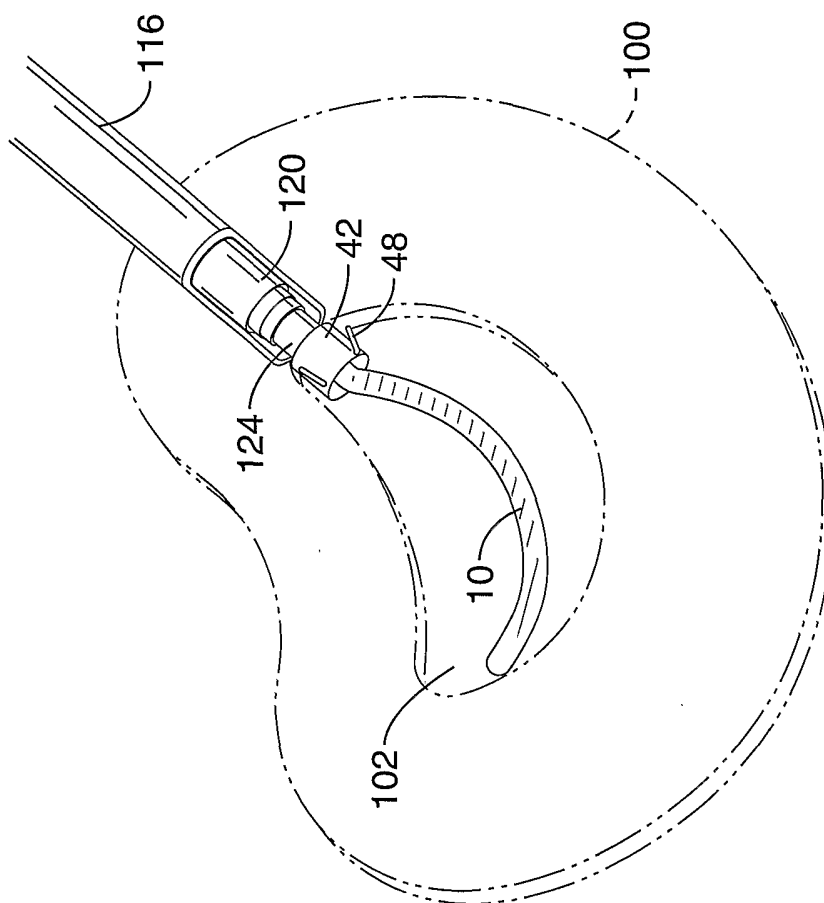
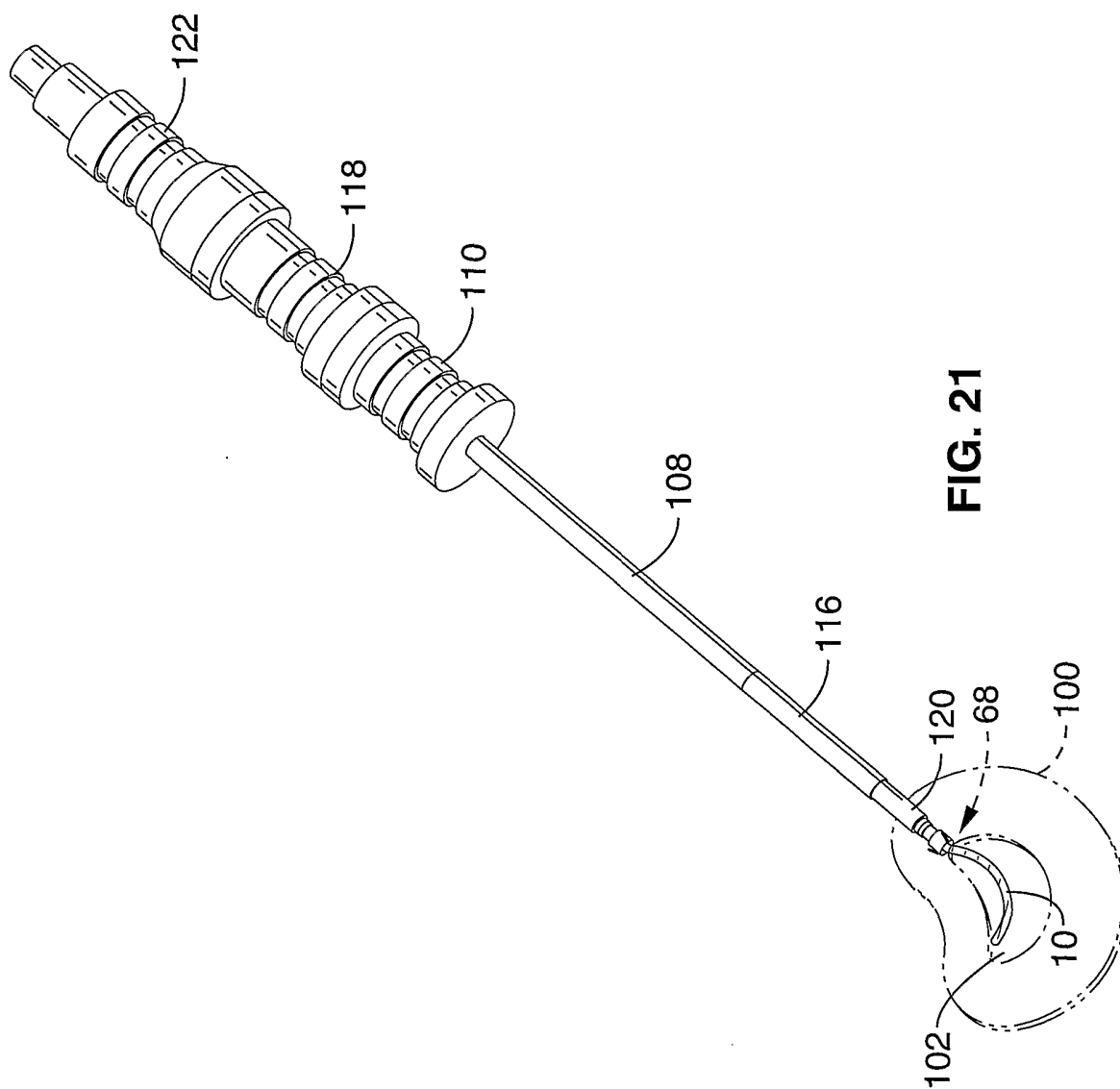

FIG. 20



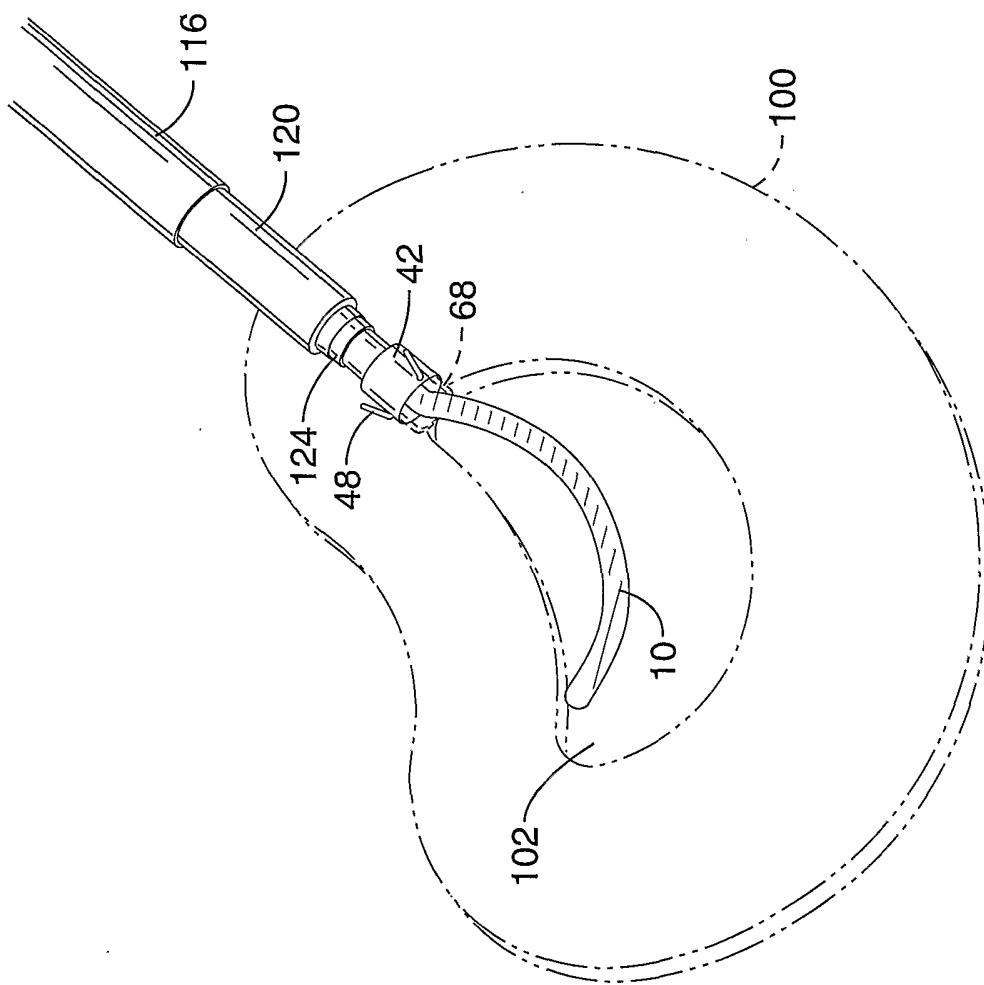

FIG. 22

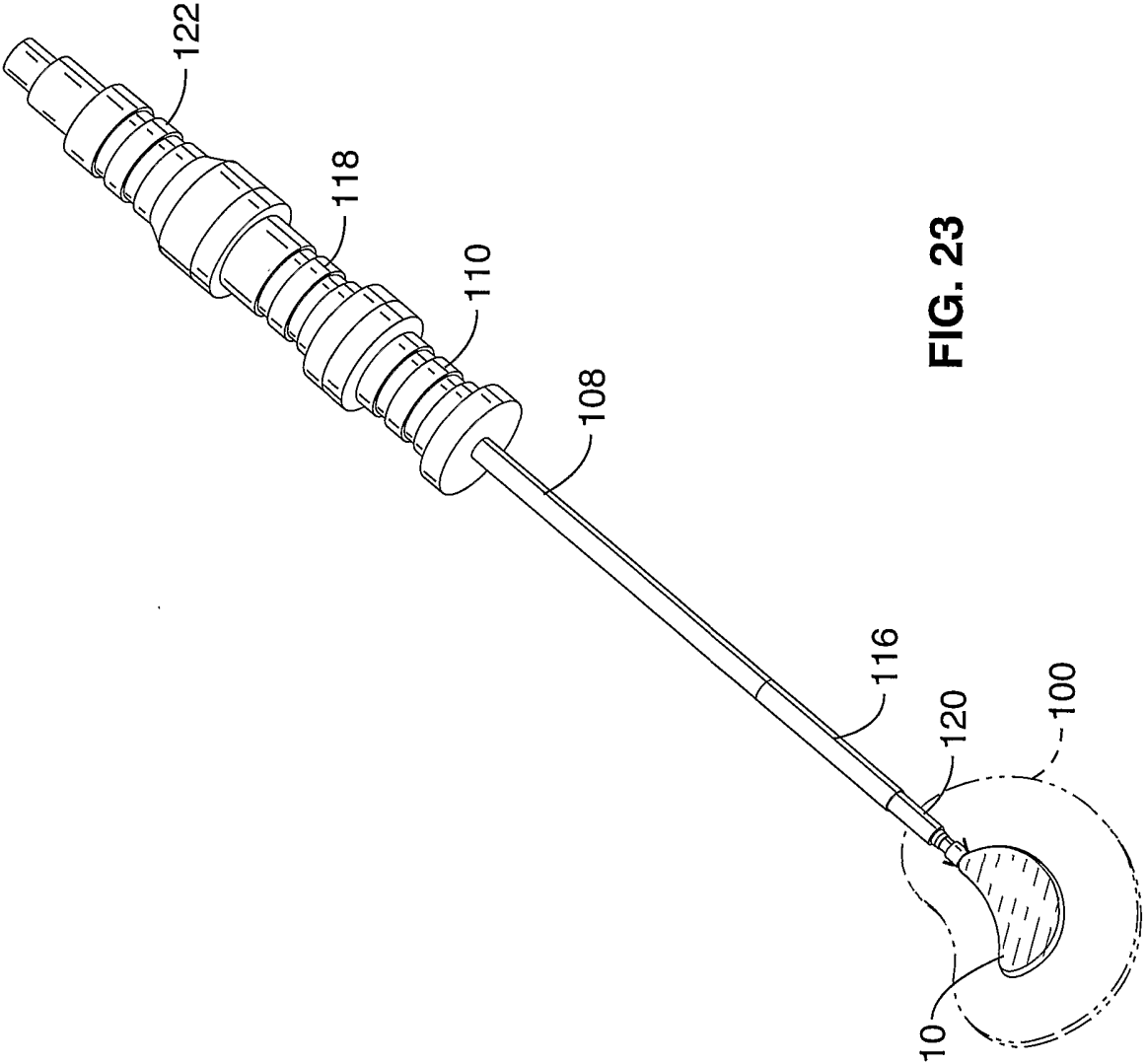

FIG. 23

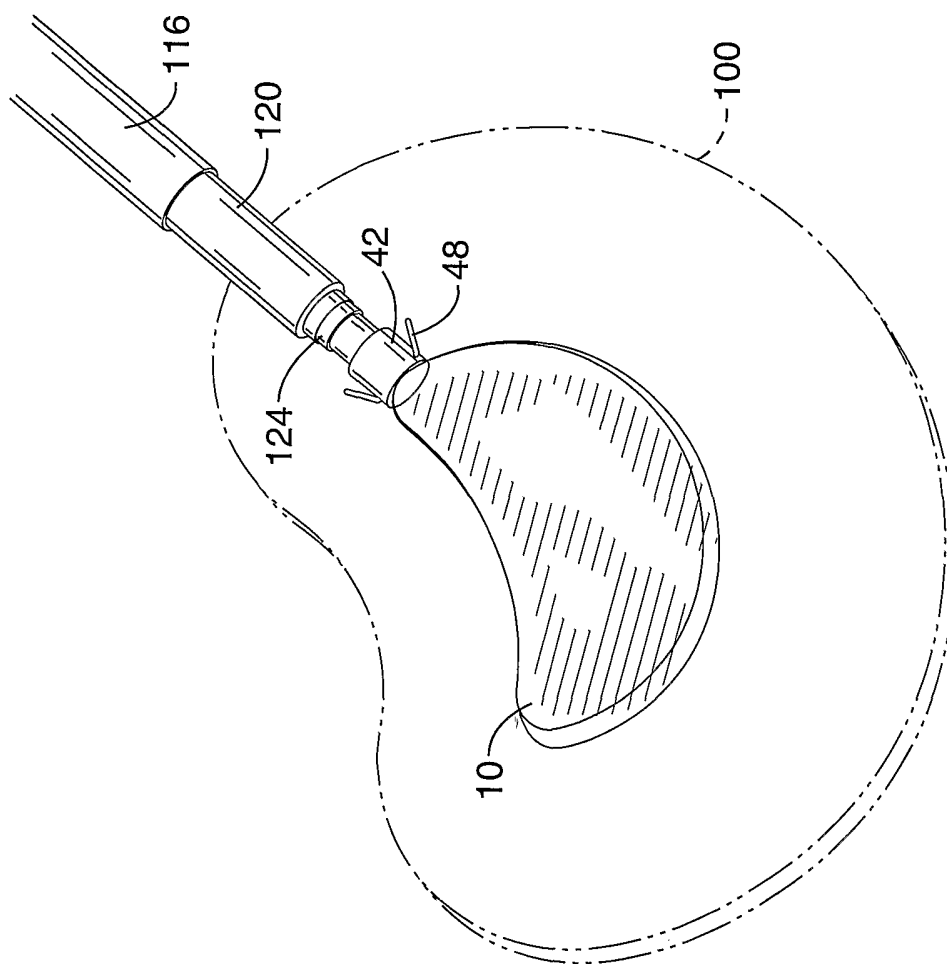

FIG. 24