



- (51) International Patent Classification:
G01N 21/78 (2006.01) G01N 33/53 (2006.01)
G01N 33/50 (2006.01)
- (21) International Application Number:
PCT/US2017/057041
- (22) International Filing Date:
17 October 2017 (17.10.2017)
- (25) Filing Language: English
- (26) Publication Language: English
- (30) Priority Data:
15/295,398 17 October 2016 (17.10.2016) US
62/409,077 17 October 2016 (17.10.2016) US
15/295,353 17 October 2016 (17.10.2016) US
62/409,089 17 October 2016 (17.10.2016) US
- (71) Applicant: RELIANT IMMUNE DIAGNOSTICS, LLC [US/US]; 6500 River Place Blvd, Building 4 Suite 102, Austin, TX 78730 (US).
- (72) Inventors: PULTIZER, Jovan Hutton; 9328 Wichita Trail, Frisco, TX 75034 (US). LEGERE, Henry Joseph III; 5925 Standing Rock Drive, Austin, TX 78730 (US).
- (74) Agent: HARDEN, Keith D.; Munck Wilson Mandala, LLP, P.O. Drawer 800889, Dallas, TX 75380 (US).
- (81) Designated States (unless otherwise indicated, for every kind of national protection available): AE, AG, AL, AM, AO, AT, AU, AZ, BA, BB, BG, BH, BN, BR, BW, BY, BZ, CA, CH, CL, CN, CO, CR, CU, CZ, DE, DJ, DK, DM, DO, DZ, EC, EE, EG, ES, FI, GB, GD, GE, GH, GM, GT, HN, HR, HU, ID, IL, IN, IR, IS, JO, JP, KE, KG, KH, KN, KP, KR, KW, KZ, LA, LC, LK, LR, LS, LU, LY, MA, MD, ME, MG, MK, MN, MW, MX, MY, MZ, NA, NG, NI, NO, NZ, OM, PA, PE, PG, PH, PL, PT, QA, RO, RS, RU, RW, SA,

(54) Title: SYSTEM AND METHOD FOR IMMEDIATE HEALTH ASSESSMENT RESPONSE SYSTEM

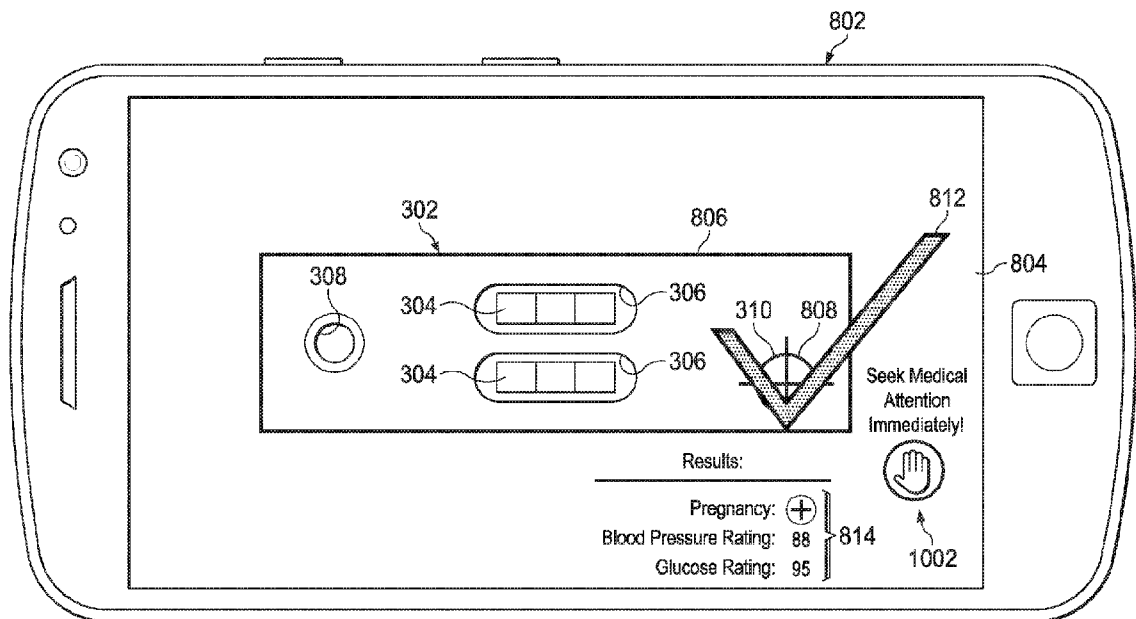

FIG. 10

(57) Abstract: An immediate health assessment response system, comprising a testing device having thereon an alignment target and having a plurality of immunoassay test strips, the plurality of immunoassay test strips each including a sample pad capable of receiving a biologic sample, and a server configured to receive information from a mobile device regarding test results from a test performed using the testing device, receive an image from a mobile device, process the image to determine results based on pixel count and line intensity of the test line of each of the plurality of immunoassay test strips, compare the results of processing the image to a control for each test line of each of the plurality of immunoassay test strips, and provide a risk indicator, wherein the risk indicator alerts a user to seek medical attention immediately.



WO 2018/075557 A1

SC, SD, SE, SG, SK, SL, SM, ST, SV, SY, TH, TJ, TM, TN,
TR, TT, TZ, UA, UG, US, UZ, VC, VN, ZA, ZM, ZW.

- (84) Designated States** (*unless otherwise indicated, for every kind of regional protection available*): ARIPO (BW, GH, GM, KE, LR, LS, MW, MZ, NA, RW, SD, SL, ST, SZ, TZ, UG, ZM, ZW), Eurasian (AM, AZ, BY, KG, KZ, RU, TJ, TM), European (AL, AT, BE, BG, CH, CY, CZ, DE, DK, EE, ES, FI, FR, GB, GR, HR, HU, IE, IS, IT, LT, LU, LV, MC, MK, MT, NL, NO, PL, PT, RO, RS, SE, SI, SK, SM, TR), OAPI (BF, BJ, CF, CG, CI, CM, GA, GN, GQ, GW, KM, ML, MR, NE, SN, TD, TG).

Declarations under Rule 4.17:

- *as to applicant's entitlement to apply for and be granted a patent (Rule 4.17(ii))*

Published:

- *with international search report (Art. 21(3))*

BACKGROUND

[0004] Home health test devices may only show that an individual has a particular health condition, but not alert the individual that medical attention should be sought. Therefore, what is needed is a system and method for home medical testing that also provides details on
5 other health conditions at a high rate of accuracy and to prompt test subject to seek medical attention when test results warrant such.

SUMMARY

[0005] In one aspect thereof, an immediate health assessment response system is provided. The system comprises a testing device having thereon an alignment target and having a plurality of immunoassay test strips, the plurality of immunoassay test strips each including a sample pad capable of receiving a biologic sample, a conjugate pad containing particles for conjugating with antibodies or antigens present in the biologic sample, and a membrane strip having a test line and a control line, wherein the test line and the control line are viewable, and a server configured to receive information from a mobile device regarding test results from a test performed using the testing device, receive an image from a mobile device, process the image to determine results based on pixel count and line intensity of the test line of each of the plurality of immunoassay test strips, compare the results of processing the image to a control for each test line of each of the plurality of immunoassay test strips, and provide a risk indicator, wherein the risk indicator alerts a user to seek medical attention immediately.

[0006] In another aspect thereof, a method for providing an immediate health assessment response is provided. The method comprises receiving at a server information from a mobile device regarding test results from a test performed using a testing device, a testing device having thereon an alignment target and having a plurality of immunoassay test strips, receiving at the server an image from the mobile device, processing at the server the image, determining results based on pixel count and line intensity of a test line of each of the plurality of immunoassay test strips, comparing the results of processing the image to a control for each test line of each of the plurality of immunoassay test strips, and providing a risk indicator, wherein the risk indicator alerts a user to seek medical attention immediately.

BRIEF DESCRIPTION OF THE DRAWINGS

[0007] For a more complete understanding, reference is now made to the following description taken in conjunction with the accompanying Drawings in which:

[0008] FIG. 1 illustrates a diagrammatic representation of one embodiment of a
5 immunoassay test strip;

[0009] FIG. 2 illustrates a diagrammatic representation of one embodiment of an immunoassay test wherein an analyte is tested across a plurality of test strips;

[0010] FIG. 3 illustrates a diagrammatic representation of one embodiment of a testing device;

10 [0011] FIG. 4 illustrates a top view of the testing device of FIG. 3;

[0012] FIG. 5 illustrates a top view of one embodiment of a testing device;

[0013] FIG. 6 illustrates a top view of another embodiment of a testing device;

[0014] FIG 7 illustrates a flowchart of one embodiment of a testing device use method;

15 [0015] FIG. 8A illustrates a diagrammatic representation of one embodiment of a process for a mobile device application for testing device image capture and image processing, wherein an image alignment indicator is not aligned with the subject of the image;

[0016] FIG. 8B illustrates a diagrammatic representation of one embodiment of a process for a mobile device application for testing device image capture and image processing, wherein an image alignment indicator is aligned with the subject of the image;

20 [0017] FIG. 9 illustrates a flowchart of one embodiment of an image analysis process using a mobile device;

[0018] FIG. 10 illustrates a diagrammatic representation of another embodiment of a process for a mobile device application for testing device image capture and image processing, wherein an image alignment indicator is aligned with the subject of the image;

[0019] FIG. 11 illustrates one embodiment of a consumer driven biologic and disease data collection system;

[0020] FIG. 12 illustrates one embodiment of a consumer driven biologic and disease data collection system;

[0021] FIG. 13 illustrates an example of a unique biologic ID database table;

[0022] FIG. 14 illustrates a flowchart of one embodiment of a biologic data collection and dissemination process;

[0023] FIG. 15 illustrates a perspective view of a system for scanning test strips;

[0024] FIG. 16 illustrates a cross-sectional view of the system of FIG. 15;

[0025] FIG. 17 illustrates one embodiment of a vertical flow immunoassay device; and

[0026] FIG. 18 illustrates a cross-sectional view of one embodiment of the vertical immunoassay device of FIG. 17.

DETAILED DESCRIPTION

[0027] Referring now to the drawings, wherein like reference numbers are used herein to designate like elements throughout, the various views and embodiments of an arbovirus indicative birth defect risk test are illustrated and described, and other possible embodiments are described. The figures are not necessarily drawn to scale, and in some instances the drawings have been exaggerated and/or simplified in places for illustrative purposes only. One of ordinary skill in the art will appreciate the many possible applications and variations based on the following examples of possible embodiments.

[0028] Referring now to FIG. 1, there is illustrated one embodiment of an immunoassay test strip 100. The test strip 100 is typically housed in a testing device configured to collect a biologic analyte 106 from a user and to direct to the biologic analyte 106 onto the testing strip 100. However, it will be understood that the biologic may be applied onto a strip 100 without the strip 100 needing to be within a testing device. The test strip 100 includes a backing 102. The test strip 100 is made up of multiple sections disposed on the backing 102. A sample pad 104 is disposed on one end of the strip 100, for collecting the biologic analyte 106. The biologic analyte 106 may be any biologic needed for use in the immunoassay, such as urine, blood, saliva, stool, sweat, or other biologics to be used as an analyte. Various methods may be used to acquire the needed biologic, and such may be provided to the user packaged with the test, such as swabs, vials, containers, dilutants and other solutions, or any other equipment required. In the case of a blood analyte, a few drops of blood may be obtained from a finger stick using a finger prick device. Such a blood analyte may be blood mixed with an adequate amount of buffered solution to create the sample analyte 106 or a blood sample that is not diluted or otherwise manipulated, in which case the blood only is the analyte 106.

[0029] The biologic analyte 106, after coming into contact with the sample pad 104, begins to migrate across the strip 100 by capillary action, coming into contact with other sections of the strip 100. A particle conjugate pad 108 is disposed between the sample pad 104 and a test line 110. The conjugate pad 108 may contain various reagents associated with a particular antigen, such as a virus, allergen, or bacteria, the reagents being items such as antibodies, enzymes, or other reagents needed to diagnose the particular condition. The reagent in the conjugate pad 108 may be conjugated with particles of materials such as colloid gold or colored latex beads. As the analyte 106 migrates through the conjugate pad

108, antibodies present in the sample analyte 106 complex with the reagents in the conjugate pad 108, thereby creating an immune complex that will migrate to the test zone or test line 110.

[0030] The test line 110 (T) may be precoated with the relevant antigen in question, i.e., a virus, allergen, or bacteria, for the detection of antibodies associated with the particular antigen. The immune complex created when the analyte 106 passes through the conjugate pad 108 is captured onto the antigen contained on the test line 110. This may create a qualitative response on the strip where the test line 110 is located, such as a colored response. In some embodiments, the test line 110 may not be a line, but may be other shapes or symbols, such as a plus sign. If no antigen-anti-antigen complexes are present in the analyte, no reaction occurs in the test line 110 and a qualitative response will not occur.

[0031] After passing through the test line 110, the analyte migrates further along the strip to reach a control line 112, where excess anti-antibody-colloidal gold or latex conjugates get bound. A qualitative response may be shown at the control line 112, indicating that the sample has adequately migrated across the testing membrane or substrate as intended. It will be understood that the control line 112 is not necessarily needed to perform the test, and may be eliminated entirely, but the control line 112 does provide a comparative example for a user reading the test. For example, the control line 112, in embodiments where a colored qualitative response is provided, may appear as an overly saturated color, such as a dark or bright saturated red, once the sample reaches the control line 112. This saturated color may be used as a comparison against the qualitative response shown on the test line 110. For example, if the qualitative response shown on the test line 110 is a much lighter red than that on the test line 110, it may be that very little reaction occurred at the test line. Of course, if no response is shown at all at the test line 110, no reaction has occurred. If the qualitative response at the test line 110 is of a similar saturation to the control line 112, a strong reaction is indicated.

[0032] The strip 100 may not be a continuous substrate. Rather, the various sections of the strip 100 may be separate from each other, but all adhered to the backing 102. As shown in FIG. 1, the sample pad 104 and the conjugate pad 108 are separate structures from each other. The test line 100 or zone and the control line 112 or zone are both disposed as part of a nitrocellulose membrane strip 114. The nitrocellulose membrane strip 114 is also adhered to

the backing 102, but separate from the sample pad 104 and the conjugate pad 106. As shown in FIG. 1, the end of the sample pad 104 adjacent to the conjugate pad 106 may overlap the conjugate pad 106, with that end of the sample pad 106 lying over the adjacent end of the conjugate pad 106. Similarly, the end of the conjugate pad adjacent to the nitrocellulose membrane strip 114 may lie over the end of the nitrocellulose membrane adjacent to the conjugate pad. This allows for the analyte 106 to be more easily deposited onto each section of the strip 100 as it migrates across the strip 100. After the analyte 106 migrates across the nitrocellulose membrane strip 114, and thus across the test line 110 and the control line 112, the analyte 106 comes into contact with a wick 116 for absorption and collection of the analyte 106. The end of the wick 116 adjacent to the nitrocellulose membrane strip 114 may lie over that adjacent end of the nitrocellulose membrane strip 114, as shown in FIG. 1.

[0033] Several Flow Immune Assays have been directed toward identifying proteins, molecules of interest, and even immunoglobulins IgG, IgA, and IgM. IgE is an antibody (immunoglobulin E) that is normally present in the blood freely circulating until it moves into the tissue where it is bound to mast cells through the receptor FcERI (F-C-epsilon-R-one) otherwise known as the high affinity IgE receptor. There is a small amount of IgE bound to IgE receptors (high and low affinity receptors) on basophils, eosinophils, and other cells in the blood and tissues.

[0034] Many assay systems are geared toward the detection of infectious proteins. All of the aforementioned tests use a non-human antibody – usually IgG type – e.g., goat IgG antibody directed against a protein of interest to detect the protein of interest from the sample (blood, urine, saliva, sweat, etc.). This antibody complexes with protein of interest and forms a complex that travels across the membrane until it reaches the test zone. In the test zone there is an IgG type antibody directed against IgG from that species of animal. As further described herein, the present detecting apparatus and method use human (patient/consumer-derived) antibodies from the sample and the test zone that contains a humanized antibody directed against the protein of interest that is pre-conjugated to a detecting substance that results in a visual change.

[0035] Summary of Target Antigen:

The target antigens may be proteins, glycoproteins, lipoproteins or other molecular substances capable of eliciting an immune reaction and/or being bound by human specific IgE (sIgE).

[0036] Immune assay to detect specific IgE:

5 In the detecting apparatus and method of using the same, the antigens are proteins conjugated to a noble metal, for example, gold, or latex conjugated to antigen in the test zone, for the purpose of detecting the presence of specific IgE (e.g., anti-peanut IgE in a blood sample from a finger prick). For example, an IgG class antibody (IgG1, IgG2, IgG3, or IgG4) or fragments of those classes of antibodies (fab
10 fragments) whose origin may be any animal species (goat, rat, human, etc.) capable of detecting human IgE (anti-IgE IgG) – a suitable commercially available humanized antibody, such as omalizumab may be used – may be used to form immune complexes of IgG-anti-IgE-sIgE that will migrate to the test zone having selected specific IgE that can bind to the conjugated antigen.

15 **[0037]** Immune assay to detect total IgE (not concerned about specific IgE):

Another embodiment includes using an IgG class antibody (IgG1, IgG2, IgG3, or IgG4) or fragments of those classes of antibodies (fab fragments) whose origin may be any animal species (goat, rat, human, etc.) capable of detecting human IgE (anti-IgE IgG) – a suitable commercially available humanized antibody that is
20 preconjugated to a detecting molecule that results in a color change when bound to IgE as the target antigen in the test zone.

[0038] Referring now to FIG. 2, there is illustrated one embodiment of an immunoassay test 200 wherein an analyte 202 is tested across a plurality of test strips 204. The plurality of test strips 204 may each be configured for testing for a particular antigen. For instance, one
25 strip may be for testing for the presence of streptococcal bacteria (strep throat), one strip may be for testing for a peanut allergy, one strip may be for testing for the Zika virus, etc. Additionally, each strip may also test for multiple antigens. For example, as shown in FIG. 2, multiple testing panels or lines maybe be incorporated. Each line may be for a particular antigen. As shown in FIG. 2, multiple test lines 206, 208, and 208 may be disposed along the

plurality of strips 204. A strip testing for allergens may have a panel for testing for peanut allergies shown at test line 206 (CH1), for cat allergies shown at test line 208 (CH2), or grass allergies shown at test line 210 (CH3).

[0039] Other examples of configurations for the testing panels can be, but are not limited to: 1) Food 5: Peanut, milk, soy, wheat, egg; 2) Nut and seed panel: almond, cashew, hazelnut, peanut, pecan, walnut, sesame seed, sunflower seed; 3) seafood: crab, lobster, shrimp, salmon, tuna; 4) Pets: cat, dog; 5) Indoor allergens: dust mites, mold mix (alternaria, aspergillus, penicillium, cladosporium), cat, dog; and 6) seasonal allergens: grass (Bermuda, bahia, Johnson, rye, timothy), trees (oak, elm, cedar, mesquite, pine, etc.), weeds (pigweed, ragweed, sage, Russian thistle).

[0040] With respect to other non-allergen antigens, the panels may be for testing for strep, Zika, flu, anthrax, cold viruses, cancer, HPV, Lyme disease, mononucleosis (mono), and other illnesses, and/or other conditions such as pregnancy (hCG detection) and disease risks. Some embodiments may allow for the testing of various arboviruses (arthropod-borne viruses). Arboviruses are viruses that are transmitted by arthropods, with mosquitos being a common vector for the virus. Vectors are organisms that transfer the virus from a host that carries the virus. Thus, in the case of mosquitos, a mosquito that feeds on a host that is infected with a virus may infect others when that mosquito again feeds on an uninfected host. Well-known arboviruses include Dengue virus, Japanese encephalitis virus, Rift Valley fever virus, West Nile virus, yellow fever virus, chikungunya, and Zika virus. Urine, blood, and saliva and other biologics may be used for arboviruses testing.

[0041] Certain antigens or medical conditions may be logically paired together. For instance, a testing device may include both a strip for detection of pregnancy and a strip for the detection of the zika virus, as the Zika virus has been known to cause birth defects in infants born to pregnant women that are infected with Zika. Thus, combining these two tests into a single testing device or kit would alert a woman to a potential Zika infection proximate in time to the time she also discovers she is pregnant, allowing the woman to seek medical attention immediately. This is a substantial improvement over past Zika testing, where a woman may be required to wait weeks before results are returned from a lab after having the biologic collected by her physician. In many cases, this may lead to a woman having passed a state-mandated cutoff point for abortions, such as 24 weeks in some states. Combining a

Zika test with a pregnancy test and physically linking the two tests, and thus allowing for a woman to determine a Zika risk at the time of taking a pregnancy test, in which a pregnancy test may be taken as soon as six days after conception, allows for that woman to take action much sooner than the state mandated cutoff and waiting for lab results would allow.

5 [0042] Various testing devices that include the test strip 100 or strips may be used, such as a slide that supports the test strip 100, a cassette based diagnostic test, a dipstick, or combinations thereof. The test results in various embodiments may be in the form of a visual qualitative reading test, a visual semiquantitative format, a reader quantitative assay format, and/or combinations thereof. Additionally, an electronic implementation may be used where
10 the result is displayed digitally on a screen disposed within the apparatus, and visible to the user.

[0043] The apparatus and method of detection may be a “one-step” approach from sample to reading without sample dilution or other sample manipulation. The sample may be diluted or endure other sample manipulation, for example the blood sample is diluted with a
15 buffer.

[0044] Referring now to FIG. 3, there is illustrated a diagrammatic representation of one embodiment of a testing device 300. The testing device 300 includes a housing 302 that forms the body of the testing device. The housing 302 may be made of plastic, metal, or any material durable enough for shipping and subsequent handling by a user. The housing 302
20 may be hollow so that a plurality of test strips 304 may be housed within and so that a biologic may be deposited within the housing 302. The testing device 300 may further have a plurality of windows 306, each window being associated with one of the plurality of test strips 304, and allowing for a user to view at least the section of the nitrocellulose membrane strip 114 where the test line 110 and control line 112 are located. The plurality of windows
25 306 may be open, or covered with plastic, glass, or other materials that allow for viewing the plurality of strips 304. A sample well 308 may be disposed on a surface of the housing 302 to allow a user to deposit a biologic into the housing 302. The sample well 308 would be disposed over or near the sample pad 104 of the test strip or strips 100. In the embodiment shown in FIG. 3, a single sample well 308 is included for collection of a single type of
30 biologic for testing, with each of the plurality of strips 304 being suited for testing for antigens using that particular biologic sample type. For example, if the testing device 300 is

a combined pregnancy and Zika test, having both a pregnancy strip and a Zika strip, a urine sample may be deposited into the sample well 308, causing the urine sample to come into contact with the sample pad 104 on both the pregnancy strip and the Zika strip. It will be understood that both of these tests may also be performed with a blood sample.

5 [0045] The testing device 300 may also have disposed on the surface of the housing a crosshair symbol 310, used as an alignment target. This symbol may be a graphic printed or adhered to the testing device 300. The crosshair symbol 310 is used to align the testing device 300 for the taking of an image of the testing device 300 using a camera on a mobile device, for use in a mobile device application described herein. In other embodiments, the
10 crosshair symbol 310 may be other types of symbols, such as a simple shape (circle, square, etc.), other images (such as a medical cross symbol, an arrow, etc.), or any other type of image.

[0046] Referring now to FIG. 4, there is illustrated a top view of the testing device 300. There is again shown the housing 302, the plurality of test strips 304, the plurality of
15 windows 306, the sample well 308, and the crosshair symbol 310.

[0047] Referring now to FIG. 5, there is illustrated a top view of one embodiment of a testing device 500. The testing device 500 includes a housing 502 having a plurality of test strips 504 within the housing 502 and a plurality of windows 506 for display of the plurality of strips 504. The housing 502 also includes a plurality of sample wells 508 disposed on one
20 side of the testing device 500. Each of the plurality of sample wells 508 is associated with one of the plurality of test strips 504 and each of the plurality of sample wells 508 may be disposed over one of the sample pads 104 on the associated one of the plurality of test strips 504. This allows for a biologic to be deposited into each of the plurality of sample wells 508, with each well 508 serving to transfer the biologic to the test strip underneath the sample
25 well. The testing device 500 further includes a crosshair 510. The crosshair symbol 510 is used to align the testing device 500 for the taking of an image of the testing device 500 using a camera on a mobile device, for use in a mobile device application described herein.

[0048] Referring now to FIG. 6, there is illustrated a top view of another embodiment of a testing device 600. The testing device 600 includes a housing 602 having a plurality of test strips 604 within the housing 602 and a plurality of windows 606 for display of the plurality
30

of strips 604. The housing 602 also includes a plurality of sample wells 608. In this embodiment, the sample wells are located on different ends of the housing 602. In the case of a two test strip device, the sample wells 608 are disposed on opposite ends of the testing device 600. The strips 604 would be arranged within the housing in such a way as to allow the sample pad 104 on each of the strip to be disposed underneath one of the sample wells 608. This is useful for testing devices that require different biological samples. For example, if the testing device 600 required a urine sample for one strip and a blood sample for the other strip, having the wells 608 disposed on opposite sides of the testing device would reduce the likelihood that a urine sample, for instance, might be inadvertently deposited into the well designated for the blood sample. In embodiments where there are more than two strips, and more than two wells, the well positions may alternate between the two sides of the testing device. For instance, a first well for a first strip might be disposed on the left side of the testing device, a second well for a second strip might be disposed on the right side of the testing device, a third well for a third strip might be disposed on the left side of the testing device, a fourth well for a fourth strip might be disposed on the right side of the testing device, and so on. The testing device 600 further includes a crosshair 610. The crosshair symbol 610 is used to align the testing device 600 for the taking of an image of the testing device 600 using a camera on a mobile device, for use in a mobile device application described herein.

20 **[0049]** The diagnostic test can, for example, be produced in a various formats for different users, such as, but not limited to, consumer/in-home use where the test is purchased through retail channels which will allow individuals to get an immediate, cost-effective test result that can lead to specific avoidance and treatment through follow-up with a medical professional.

25 **[0050]** The diagnostic test can be provided to and used by hospitals and clinics to provide rapid, on-site test results that are required to prescribe certain medications, such as omalizumab, by their FDA labels.

[0051] This diagnostic assay can be modified to detect the presence of specific IgE in pets.

[0052] It is also noted that housing 602 is designed such that both strips 604 are disposed in physical proximity thereto and in the same actual housing. In this manner, both sets are linked physically to each other such that they cannot be separated and can be associated with a single individual and the actual test cannot be separated. As such, when a patient applies the specimens to the two areas 608 and the test results are exhibited, there is a high probability that two tests were performed at the same time associated with the same patient. Additionally, an electronic chip (not shown) can be embedded within the housing 602 such that the housing 602 can be registered to a specific patient and associated with the medical records of that patient.

10 [0053] Referring now to FIG. 7, there is illustrated a flowchart of one embodiment of a testing device use method 700. The method 700 begins at step 702 where a biologic is collected in a sample well or wells of a testing device. The biologic collected may be a non-diluted or non-manipulated biologic, such as blood, urine, or saliva from the user of the test. Diluted or manipulated biologics may be used instead, as required by the specific test. For example, if a viral test requires the biologic to be added to a solution, the biologic could be added to a solution that has previously been placed in a sterilized vial provided with the testing device. After the required amount of time has passed, the solution containing the biologic could be deposited into the well or wells. At step 704, the biologic contacts a sample pad disposed on a strip or strips within the testing device. At step 706, the biologic migrates along the strip or strips to come into contact with a conjugate pad containing antibodies. Antibodies present in the biologic will complex with the antibodies in the conjugate pad to create an immune complex. At step 708, the biologic migrates into a test zone of the strip or strips, coming into contact with an antigen. The antibodies in the conjugate pad serve to provide a means of detection, such as a colored response, if the immune complex binds with the antigen present in the test zone of the strip. At decision block 710, binding of the antibodies with the antigen may or may not occur depending on if antibodies associated with the antigen are present in the biologic or not. If a binding between the antibodies and the antigen does not occur the process moves to step 712 where no qualitative response is produced on the test line. If a binding does occur, at step 714 a qualitative response is produced on the test line. Whether a binding occurs or not, and whether a qualitative response is produced or not, the process moves to step 716 where the biologic migrates into a control zone of the strip or strips where excess conjugates get bound

and produces a qualitative control zone reaction indicating that the sample has adequately migrated across the testing zone.

[0054] It will be understood by one skilled in the art that the antibodies and antigens applied to the testing strip may be altered depending on the type of condition being tested.

5 For example, in the case of testing for medical conditions that do not involve an illness or infection, like pregnancy, and thus the sample biologic does not contain antibodies associated with the condition, antibodies that react to markers being tested for may be applied to the testing strip instead of an antigen. For instance, pregnancy test requires testing for the presence of hCG. Since hCG is a hormone and not an antibody produced in response to an
10 infection, the testing strip may have antibodies that will react to the presence of hCG applied to the testing zone or line of the testing strip, as well as to the conjugate pad. Similarly, some tests might require antibodies be applied to the testing strip to detect antigens present in the sample, rather than antibodies.

[0055] Referring now to FIGS. 8A and 8B, there is illustrated a diagrammatic view of
15 one embodiment of a process 800 for a mobile device application for testing device image capture and image processing. The mobile device application allows for an image of a testing device, such as testing device 300, to be captured using a camera installed on a mobile device 802 having a screen 804. While the mobile device 802 displays on the screen 804 the scene captured by the camera, the mobile device application also displays a graphic on the screen
20 804 in the form of a boxed outline 806, the size of the outline 806 corresponding to the size of the testing device 300. Also displayed on the screen of the mobile device 802 within or near the outline is a crosshair graphic 808. A user of the mobile device 802 attempts to align the outline 806 with the borders of the testing device 300 and also attempts to align the crosshair graphic 808 with the crosshair 310 on the testing device 300. While alignment has
25 not yet been achieved, a misalignment warning 810 may appear on the screen of the mobile device 802, indicating to the user that alignment has not yet been achieved. Such is shown in FIG. 8A.

[0056] In FIG. 8B, there is shown the result of a successful alignment of the outline 806 with the testing device 300 and successful alignment of the crosshair graphic 808 with the
30 crosshair 310 on the testing device 300. As shown in FIG. 8B, once aligned, a success indicator 812 may appear, such as a check mark or other positive status symbol, on the

aligned image. Successful alignment causes the camera on the mobile device 802 to capture the current image of the testing device 300. Other checks may occur, including ensuring that the image is focused before the image is saved. This image is then processed to determine a result based on the severity of the reaction occurring on the test strip. The mobile device application performs an analysis of the test line captured in the image, counting the number of colored pixels, as well as determining the intensity of the color. The mobile device may then compare this number and color intensity to that in the control line, providing a mathematical evaluation of the test line. Utilizing unique wavelengths of light for illumination in conjunction with either CMOS or CCD detection technology, a signal rich image is produced of the test lines to detect the colloid gold or latex particles. This provides an advantage because a user simply looking at the two lines may not know what the test line indicates, such as when the colored line does appear on the strip, but it is a faded line, rather than a dark line. Based on this analysis, the mobile device application may provide a results indicator 814.

[0057] The results indicator 814 may be a qualitative result or a quantitative result. For example, and as shown in FIG. 8B, a qualitative result for the results indicator 814 may indicate, in the case of a testing device for testing pregnancy as well as an infection, a plus sign next to a line reading “pregnant.” and a plus sign next to a line reading “infection.” to indicate that the user is both pregnant and infected with the bacteria or virus being tested, such as the Zika virus. For a quantitative result, the results might provide a numeric rating. For instance, a rating system between 1-100 may be used. If the results provide a low rating to the user, such as a rating of 10, this indicates a low risk of infection, although medical attention may be sought by the user anyway. For example, if the user is pregnant, and also receives a 10 rating for Zika, this may indicate that Zika was detected in low amounts. However, the user may still seek medical attention or further testing from her doctor because Zika has been known to cause birth defects. If the rating is a high rating, such as 95, this indicates that an infection has most likely occurred and medical attention should be sought immediately.

[0058] This same quantitative rating system may be applied to any test (viral infections, bacterial infections, pregnancy, and other health conditions), as the quantitative test can be performed using the software described herein to accurately test bound antibody concentrations on the test strip. In some embodiments, a combined qualitative and

quantitative result may be presented, such as both a rating and a plus or minus sign being presented, or other types of quantitative and qualitative indications. Additionally, various combinations of tests may be provided for in the testing device, such as pregnancy/Zika, pregnancy/flu, pregnancy/strep/Zika, etc.

5 **[0059]** Referring now to FIG. 9, there is illustrated a flowchart of one embodiment of an image analysis process 900 using a mobile device. At step 902 a mobile device application is launched. At step 904 a camera on the mobile device is activated and a crosshair indicator and a testing device outline appear on the mobile device screen. At step 906 the crosshair indicator presented on the screen of the mobile device is aligned with a crosshair icon on the
10 testing device and the device outline presented on the screen of the mobile device is aligned with the borders of a testing device. At step 908, an indicator of successful alignment is presented on the screen and an image of the testing device is taken by the mobile device camera. At step 910, the mobile device application processes the image of the testing device to determine test line strength by counting the number of colored pixels contained in the test
15 line. At step 912, the mobile device application correlates line intensity with analyte concentrations to further determine test line strength. At step 914, the mobile device application presents the test results based on pixel count and line intensity, providing either a qualitative or quantitative result.

[0060] In some embodiments, the number of pixels indicating bound antibodies on the
20 strip may be measured against that in the control line to compare line intensity between the two lines, with the control line acting as an example of a strong reaction, indicating a strong infection, and determining how close the test line intensity is to the control line. This would lead to a logical quantitative result. For instance, if the test line is determined to have a pixel count and line intensity that is 25% of the pixel count and line intensity of the control line, a
25 rating of 25 may be given. If a qualitative result is to be provided, a rating of 25 may give a qualitative result that is negative, or it could be positive depending on the type of condition being tested and known actual infection results where a rating of 25 occurred for that condition.

[0061] In some embodiments, the test line may not be compared with the control line to
30 determine a result. Rather, the mobile device application may have access to a database having data on numerous past tests for the same condition. This data may instead be used as

the control. This allows the application on the mobile device to retrieve data on past tests and compare the test line data of the current test to past tests. Overall data for past tests may be provided and compared against, such as providing an average or a curve of past tests, or individual tests rated as having accurate results may be compared against.

5 **[0062]** In addition to a status result of an infection or other medical condition being provided to the user, other indicators of health may also be tested and results thereon provided. This provides for potential early identification of pregnancy and risk of morbidity, allowing for medical attention to be sought much more quickly. Indicators of health may be detected from biologics, such as urine and blood. Urine, for example, allows for the
10 detection of glucose levels, proteins, bacteria, and infectious markers. In the case of glucose, glucose is usually not found in urine, but, if it is, that is an indicator of extremely high levels of glucose in the body, where the kidneys release excess glucose into urine. This is often a sign of diabetes. Protein in the urine may indicate a malfunctioning of the kidneys, which could be the result of high blood pressure. Similarly, if blood is detected in urine, it could be
15 a sign of a problem with the kidneys or the bladder. Blood, for example, allows for the detection of glucose, inflammation, hormones, genetic defect risks, and metabolic endocrine disorders.

[0063] Referring now to FIG. 10, there is illustrated another embodiment of a successful alignment of the outline 806 with the testing device 300 and successful alignment of the
20 crosshair graphic 808 with the crosshair 310 on the testing device 300, wherein quantitative results for health risk indicators are provided. In this embodiment, the results indicator 814 provides a qualitative result for pregnancy, and quantitative results for other health risk indicators. In the embodiment shown in FIG. 10, the health risk indicators being tested are markers for blood pressure and for glucose levels. For blood pressure, this is a test for
25 markers in the blood that can be associated with high blood pressure. These could be test for such things as low levels of vitamin D and the such. Studies have shown that patients suffering from essential hypertension will be under oxidative stress and Malondialdehyde (MDA) is the principal and most studied product of polyunsaturated fatty acid pre-oxidation. This can show an indirect correlation with anti-oxidants, particularly with superoxide
30 dismutases (SODs) ($r=0.573$) and catalase ($r=0.633$) representative anti-oxidant are involved in reducing the stress of a patient's biological system during hypertension. Another marker for hypertension is buildup of uric acid, where in uric acid is a marker for xanthine oxidase-

associated oxidants and that the latter could be driving the hypertensive response. Additional markers are cortisol, a hormone. The test strips 604 can test for the different biological markers.

5 [0064] The results indicator 814 provides numeric ratings, in this case, 1-100, with the blood pressure rating being 88 and the glucose rating being 95. This indicates that both blood pressure and glucose are extremely high. Due to this, an additional alert indicator 1002 is presented to the user on the screen of the mobile device, alerting the user to seek medical attention immediately. This is to ensure that the health of both the pregnant woman and the fetus can be checked as close to the time of pregnancy detection as possible and medical
10 attention received if needed.

[0065] Referring now to FIG. 11, there is provided a flowchart of one embodiment of a pregnancy disease risk assessment process 1100. The process 1100 begins at step 1102 where a biologic is collected and deposited in a testing device for testing of the biologic. At step 1104, the biologic is processed by the testing device for detection of pregnancy and
15 various other medical conditions. These medical conditions may be high blood pressure, diabetes, bacterial or viral infections, inflammation, an increase in hormone levels, genetic disease markers, and/or metabolic disorders. At step 1106, a mobile device is used to capture an image of the testing device after testing is complete. In some embodiments, test results may be immediate. In other embodiments, and depending on the medical conditions being
20 tested, the test may take a certain amount of time to complete. In this case, the user of the test would be alerted to this fact in instructions provided with the testing device. Additionally, a visual indicator on the testing device may alert the user that a test is now complete. At step 1108, the mobile device provides a rating for each medical condition being tested, such as that described with respect to FIG. 10 herein.

25 [0066] At decision block 1110, it is determined whether the ratings for each condition exceed a certain threshold for that condition. If not, the process 1100 moves to step 1112, where an indication is presented to the user via the mobile device screen that medical attention is not currently advised or necessary. If at step 1110 it is determined that at least one of the medical conditions being tested rises above a certain threshold, the process 1100
30 moves to step 1114 where a warning is presented to the user via the mobile device screen that medical attention is advised. The thresholds for medical conditions may not trigger a

warning even if a rating exceeds a threshold, if, in the event of multiple tests being performed, the combined test results do not warrant immediate medical attention. For example, if a user is testing for a cold virus, blood pressure, and glucose, and only the cold virus rating is above the threshold, there may not be a warning provided to the user.

5 Additionally, ratings may be weighted or aggregated based on the medical conditions being tested. For example, if blood pressure, inflammation, and glucose are being tested for, and they all are given only moderate ratings that do not rise above the threshold for any condition individually, an warning to seek medical attention may still be provided due to the combination of conditions taken together.

10 **[0067]** Referring now to FIG. 12, there is illustrated one embodiment of a consumer driven biologic and disease data collection system 1200. Data collected from users performing the tests disclosed herein effectively can provide a wealth of information. As tests are performed data may be passed by a plurality of mobile devices 1202 being used by users performing tests to a database 1204, the database being at a remote server 1206, over a
15 network 1208. The user is sourcing a biologic from user's own body. This is done at home, not in a lab, hospital, or clinic. Each particular test would expect a certain type of biologic to be provided. For instance, for a pregnancy test, a urine sample is provided and tested for pregnancy markers. For a stool test, the stool might be dissolved in a vial with a solution provided with the testing device/kit, and tested for various disease or infectious markers.
20 Data and results from the tests may be stored on the database 1204 at the remote server 1206. As described herein, this data may be used as a control for testing analysis for users of the plurality of mobile devices 1202. This data may also be used to provide data sets for biologics to a medical organization 1210. The medical organization 1210 may be doctor's offices, researchers, hospitals, testing labs, and other individuals or organizations that have an
25 interest in the health and analysis of users taking the test and of their biologic samples. In this way, data can be gathered from a variety of biologics tested for a variety of different medical conditions and characteristics.

[0068] Referring now to FIG. 13, there is illustrated an example of a unique biologic ID database table 1300. The table 1300 is illustrative of the type of data stored in association
30 with data for a biologic transmitted by the plurality of mobile devices 1202 for storage on the database 1204. A biologic ID header 1302 is provided that shows that the biologic sample has been given a unique ID. All data concerning the biologic may be stored in association

with the unique biologic ID. The table 1300 also includes a biologic type entry 1304. This designates what type of biologic that the biologic associated with the unique ID is, such as blood, urine, stool, saliva, sweat, or other biologics. The table 1300 also provides a plurality of test ratings 1304, for various tests performed on the biologic. In the example shown in FIG. 13, a blood biologic is provided having an assigned ID of 2402, and having been testing for pregnancy markers, the Zika virus, and for glucose levels. The rating for pregnancy was a 99 rating, the rating for a Zika infection was a 75, and the rating for glucose levels was a 10. This would indicate that the test subject has an extremely high likelihood of both a pregnancy and a Zika infection, which would have resulted in a warning to seek medical attention at the conclusion of the tests. Other information may also be stored in the database in relation to the biologic, including other condition ratings, time and date each test was performed, user information such as ethnicity, gender, and age, and status indicators such as whether a test subject visited a physician as a result of the tests. The database 1204 thus provides the test subject with a growing collection of information that may be accessed by the test subject. This allows the test subject to present the test results to her physician for medical attention or additional testing, and allows for others who may access the database, such as disease researchers, to have access to data on various biologic samples and their markers.

[0069] Referring now to FIG. 14, there is illustrated a flowchart of one embodiment of a biologic data collection and dissemination process 1400. The process 1400 begins at step 1402 where a user of a testing device collects a biologic sample for use in a test or a series of tests. At step 1404, the test or series of tests are performed on the biologic sample. At step 1406, a mobile device application checks the biologic sample the testing device result to determine a quantitative result of the test to provide a correlative value for the condition being tested in the biologic sample. At step 1408, the test results and correlative values, or multiple values if multiple tests on the biologic sample were conducted, are transmitted to the remote server 1206. At step 1410, the biologic sample is given a unique identification number in the database 1204. At step 1412, the test results and correlative value or values are stored in the database 1204 in association with the unique identification number given to the biologic sample collected and in association with the particular tests performed. This way, the particular biologic sample may have various characteristics stored and retrieved in association with the biologic sample, and the test results may also be retrieved when data on a particular test is needed on a cross-section of users.

[0070] At step 1414, the results are provided to the user on the user's mobile device. At step 1416, the results are provided to the user's healthcare provider. The healthcare provider may receive the test results due to a visit from the user, the user bringing the results of the test with her on her mobile device, or the healthcare provider may receive the results from the database 1204 if the healthcare provider has permission to access the database 1204, or if access is granted in anticipation of the user's appointment with the healthcare provider. At step 1418, the test results are also provided to other healthcare industry individuals and organizations, including medical researchers, hospitals, and others.

[0071] Referring now to FIG. 15, there is illustrated a perspective view of a system for scanning test strips. The housing 604, as described hereinabove with respect to FIG. 6, is illustrated as being disposed within a slot 1502 in a test housing 1504. The test housing 1504 is connected through a line 1506 to a PC 1508. When the housing 604 containing the test strips 604 after being subjected to the biologics is inserted within the slot 1502, the test housing 1504 will scan the test strips 604 and analyze the results with the PC 1508. The PC 1508 will run some type of algorithm that can analyze the results of both of the test strips 604. There can be provided to indicators 1510 and 1512 on the surface of the test housing 1504, one being, for example, a ready LED and one being a green LED. The PC 1508, after analyzing results, can then provide a warning indicator such as lighting up the green LED for a positive indication of pregnancy and the red LED for indicating that there is some issue. As an example, suppose that the second test strip tested for the Zika virus. If so, a warning would be appropriate to output and activate the red LED. There could be any other type of indicator associated with the second test at 604 that, in a combination with the test results of the first test strip, i.e. for testing for the presence of a pregnancy state, testing for such things as diabetes, etc. Further, although only two test strips 604 are illustrated, there could be multiple test strips testing for many different biological issues that may be present in an individual. In this embodiment, by inserting the housing 602 into the test housing 1504 and allowing the PC 1508 to analyze the results, the indicators associated with the test strips can be analyzed with the assumption that all of the test return results were associated with an individual and in proximate time to each other. That means that the individual patient applied biological specimens, such as urine, blood, etc., to the appropriate test strips and, since these were all contained within the same test strip housing 602, this provides an indication that they are associated with a single patient. Further, the test performed will typically be a test that will provide a very short-term response. Thus, the specimens can be applied to the test strips

604 in the test strip housing 602 and then inserted within the slot 1502 for testing by the PC 1508.

[0072] Referring now to FIG. 16, there is illustrated a cross-section of the test housing 1504. It can be seen that the test strip housing 1602 is passed in slot 1502 past the camera 1602. The camera 1602 is operable to scan a small cross-section of the test strips 604 on the surface thereof as the test strip housing 602 passes thereby. Of course, there could also be a much larger camera provided for taking an entire image of the test strips 604 after being inserted within the test housing 1504. The camera 1602 is connected via a wire 1604 to an electronics package 1606 to process the information and send it to the PC 1508. The electronics package 1606 will also drive the indicators 1510 and 1512.

[0073] Referring now to FIG. 17, there is illustrated one embodiment of a vertical flow immunoassay device 1700. It will be understood that testing device 300 and other embodiments herein illustrate a lateral flow immunoassay device. However, other types of immunoassay devices may be used. For example, vertical flow immunoassay devices may be used, a two-sided flow through assay, or even a sandwich ELISA test may be run.

[0074] The testing device 1700 includes a housing 1702 that forms the body of the testing device. The housing 1702 may be made of plastic, metal, or any material durable enough for shipping and subsequent handling by a user. The housing 1702 may be hollow so that a plurality of immunoassay test pads 1704 may be housed within and so that a biologic may be deposited within the housing 1702. The testing device 1700 may further have a plurality of sample wells 1706, each sample well having one of the plurality of immunoassay test pads 1704 disposed within, and allowing for a user to view at least a section of a nitrocellulose membrane of each of the immunoassay test pads 1704, the membrane 1708 having a test line 1708 and control line 1710. The testing device 1700 may also have disposed on the surface of the housing a crosshair symbol 1712, used as an alignment target. This symbol may be a graphic printed or adhered to the testing device 1700. The crosshair symbol 1712 is used to align the testing device 1700 for the taking of an image of the testing device 1700 using a camera on a mobile device, for use in a mobile device application described herein. In other embodiments, the crosshair symbol 1712 may be other types of symbols, such as a simple shape (circle, square, etc.), other images (such as a medical cross symbol, an arrow, etc.), or any other type of image. In other embodiments, the device 1700 may be configured in such a

way as to allow a biologic sample to be deposited into a sample well, and to present the results of the test on the opposite side of the housing. Such a configuration would allow the biologic to flow through the testing pad within the housing, with the reaction occurring on a reactive membrane on the side of the device opposite the sample well, with the device having
5 a window for viewing the results.

[0075] Referring now to FIG. 18, there is illustrated a cross-sectional view of one embodiment of the vertical immunoassay device 1700. There is shown one of the plurality of immunoassay test pads 1704 residing within the housing 1702 below one of the plurality of sample wells 1706. The one of the plurality of immunoassay test pads 1704 includes a
10 immunoreactive membrane 1802, such as the nitrocellulose membranes disclosed herein. The immunoreactive membrane 1802 may have particle conjugates disposed thereon that binds when a biologic sample is received onto the immunoreactive membrane 1802 via the sample well 1706, if the biologic sample contains the antigens or antibodies, or other indicators, for which the test is configured. The one of the plurality of immunoassay test
15 pads 1704 also includes an absorbent pad 1804 for collection of excess biologic sample. It will be understood that the cross-sectional view illustrated in FIG. 18 shows one well of the plurality of sample wells 1704. The other wells included in the device 1700 would be configured in a similar manner as that shown in FIG. 18. There may also be included in the device 1700 an inner separating wall between each of the plurality of immunoassay test pads
20 1704, to ensure that excess biologic material that is not adequately absorbed by the absorbent pad 1804 does not contaminate neighboring immunoassay test pads.

[0076] One example embodiment can include a system for providing pregnancy testing in conjunction with disease risk testing, comprising a testing device having thereon an alignment target and having a plurality of immunoassay test strips, the plurality of
25 immunoassay test strips each including a sample pad capable of receiving a biologic sample, a conjugate pad containing particles for conjugating with antibodies or antigens present in the biologic sample, and a membrane strip having a test line and a control line, wherein the test line and the control line are viewable, and a mobile device having a camera, a viewing screen, and a software application stored thereon, wherein the software application provides
30 executable instructions to initiate operation of the camera of the mobile device, present on the viewing screen of the mobile device an alignment graphic to be aligned with the alignment target of the testing device, detect when an alignment of the alignment graphic and the

alignment target has taken place, capture an image of the testing device, process the image to determine pixel count and color intensity of the test line of each of the plurality of immunoassay test strips, compare the results of processing the image to a control for each test line of each of the plurality of immunoassay test strips, determine a risk value for each of at least one disease risk tested using the biologic sample, wherein the risk value is a rating 5 determined from the pixel count and color intensity of the test line associated with a particular disease risk tested, assess the risk value for each of the at least one disease risk tested to determine whether immediate medical action is required, present the risk value for each of the at least one disease risk tested on the viewing screen, and present, if immediate 10 medical action is required, a medical action indicator on the viewing screen.

[0077] Another example embodiment can include a method for providing pregnancy testing in conjunction with disease risk testing, comprising collecting at least one biologic by a testing device having thereon an alignment target and having a plurality of immunoassay test strips, wherein the at least one biologic contacts a sample pad on at least one of the 15 plurality of immunoassay test strips, conjugating the at least one biologic with particles on a conjugate pad on at least one of the plurality of immunoassay test strips to create an immune complex, receiving the immune complex at a test line on a membrane strip on at least one of the plurality of immunoassay strips, wherein the test line includes particular antigens or antibodies, binding, if the immune complex contains antigens or antibodies capable of 20 binding with the particular antigens or antibodies included on the test line, the antigens or antibodies of the immune complex to the antigens or antibodies of the test line, producing a qualitative response on the test line if the antigens or antibodies of the immune complex are bound to the antigens or antibodies on the test line, providing a software application to be stored on a mobile device, the mobile device having a camera and a viewing screen, initiating 25 operation of the camera, presenting on the viewing screen an alignment graphic to be aligned with the alignment target of the testing device, detecting when an alignment of the alignment graphic and the alignment target has taken place, capturing an image of the testing device, processing the image to determine pixel count and color intensity of any qualitative response on the test line of each of the plurality of immunoassay test strips, comparing the results of 30 processing the image to a control for each test line of each of the plurality of immunoassay test strips, determining a risk value for each of at least one disease risks tested using the biologic sample, wherein the risk value is a rating determined from the pixel count and color intensity of the test line associated with a particular disease risk tested, assessing the risk

value for each of the at least one disease risks tested to determine whether immediate medical action is required, presenting the risk value for each of the at least one disease risks tested on the viewing screen, and presenting, if immediate medical action is required, a medical action indicator on the viewing screen.

5 [0078] Another example embodiment can include a method for collection and dissemination of biologic data, comprising collecting at least one biologic sample by a testing device including thereon an alignment target and including a plurality of immunoassay test strips, wherein the at least one biologic sample contacts a sample pad on at least one of the plurality of immunoassay test strips, assigning correlative values as test results, wherein each
10 test performed on the biologic sample is assigned a different correlative value, receiving the test results at a server disposed on a network, wherein the server has configured thereon a database, assigning a unique identification to the biologic sample, storing the unique identification in the database, storing the test results in the database in association with the unique identification of the biologic sample, and providing access to the database to
15 healthcare organizations for analysis of the test results.

[0079] Another example embodiment can include a system for collection and dissemination of biologic data, comprising a testing device configured to collect at least one biologic sample, the testing device including thereon an alignment target and including a plurality of immunoassay test strips, wherein the at least one biologic sample contacts a
20 sample pad on at least one of the plurality of immunoassay test strips, a server remote from the testing device and disposed on a network, the server configured to assign correlative values as test results, wherein each test performed on the biologic sample is assigned a different correlative value, receive the test results, wherein the server has configured thereon a database, assigning a unique identification to the biologic sample, storing the unique
25 identification in a database associated with the server, storing in the database the test results in association with the unique identification of the biologic sample, and providing access to the database to healthcare organizations for analysis of the test results.

[0080] Another example embodiment can include an immediate health assessment response system, comprising a testing device having thereon an alignment target and having a
30 plurality of immunoassay test strips, the plurality of immunoassay test strips each including a sample pad capable of receiving a biologic sample, a conjugate pad containing particles for

conjugating with antibodies or antigens present in the biologic sample, and a membrane strip having a test line and a control line, wherein the test line and the control line are viewable, and a server configured to receive information from a mobile device regarding test results from a test performed using the testing device, receive an image from a mobile device,
5 process the image to determine results based on pixel count and line intensity of the test line of each of the plurality of immunoassay test strips, compare the results of processing the image to a control for each test line of each of the plurality of immunoassay test strips, and provide a risk indicator, wherein the risk indicator alerts a user to seek medical attention immediately.

10 **[0081]** Another example embodiment can include a method for providing an immediate health assessment response, comprising receiving at a server information from a mobile device regarding test results from a test performed using a testing device, a testing device having thereon an alignment target and having a plurality of immunoassay test strips, receiving at the server an image from the mobile device, processing at the server the image,
15 determining results based on pixel count and line intensity of a test line of each of the plurality of immunoassay test strips, comparing the results of processing the image to a control for each test line of each of the plurality of immunoassay test strips, and providing a risk indicator, wherein the risk indicator alerts a user to seek medical attention immediately.

[0082] One or more of the above examples includes binding antigens or antibodies of an
20 immune complex to antigens or antibodies included on a control line of a membrane strip.

[0083] In one or more of the above examples, the control line serves as a control.

[0084] In one or more of the above examples, the control is a dataset from previously conducted tests stored on a database and accessed by a software application.

[0085] In one or more of the above examples, the test results include a qualitative result.

25 **[0086]** In one or more of the above examples, the test results include a quantitative result.

[0087] In one or more of the above examples, the quantitative result is a reaction rating.

[0088] In one or more of the above examples, a test line of at least one of the plurality of immunoassay test strips includes an antibody suitable for binding with hCG.

[0089] In one or more of the above examples, a test line of at least one of the plurality of immunoassay test strips includes Zika virus antigen.

5 [0090] In one or more of the above examples, a test line of one of the plurality of immunoassay test strips includes Zika virus antigen and the test line of another one of the plurality of immunoassay test strips includes an antibody suitable for binding with hCG.

[0091] It should be understood that the drawings and detailed description herein are to be regarded in an illustrative rather than a restrictive manner, and are not intended to be limiting
10 to the particular forms and examples disclosed. On the contrary, included are any further modifications, changes, rearrangements, substitutions, alternatives, design choices, and embodiments apparent to those of ordinary skill in the art, without departing from the spirit and scope hereof, as defined by the following claims. Thus, it is intended that the following claims be interpreted to embrace all such further modifications, changes, rearrangements,
15 substitutions, alternatives, design choices, and embodiments.

[0092] It should be understood that the drawings and detailed description herein are to be regarded in an illustrative rather than a restrictive manner, and are not intended to be limiting
20 to the particular forms and examples disclosed. On the contrary, included are any further modifications, changes, rearrangements, substitutions, alternatives, design choices, and embodiments apparent to those of ordinary skill in the art, without departing from the spirit and scope hereof, as defined by the following claims. Thus, it is intended that the following claims be interpreted to embrace all such further modifications, changes, rearrangements, substitutions, alternatives, design choices, and embodiments.

WHAT IS CLAIMED IS:

1. An immediate health assessment response system, comprising:
 - a testing device having thereon an alignment target and having a plurality of immunoassay test strips, the plurality of immunoassay test strips each including:
 - 5 a sample pad capable of receiving a biologic sample;
 - a conjugate pad containing particles for conjugating with antibodies or antigens present in the biologic sample; and
 - a membrane strip having a test line and a control line, wherein the test line and the control line are viewable; and
 - 10 a server configured to:
 - receive information from a mobile device regarding test results from a test performed using the testing device;
 - receive an image from a mobile device;
 - process the image to determine results based on pixel count and line
 - 15 intensity of the test line of each of the plurality of immunoassay test strips;
 - compare the results of processing the image to a control for each test line of each of the plurality of immunoassay test strips; and
 - provide a risk indicator, wherein the risk indicator alerts a user to seek medical attention immediately.
- 20 2. The immediate health assessment response system of Claim 1, wherein the testing device is further configured to bind antigens or antibodies of an immune complex to antigens or antibodies included on a control line of a membrane strip of the testing device.
- 25 3. The immediate health assessment response system of Claim 2, wherein the control line serves as a control.
4. The immediate health assessment response system of Claim 3, wherein the control is a dataset from previously conducted tests stored on a database and accessed by a software
- 30 application.
5. The immediate health assessment response system of Claim 1, wherein the test results include a qualitative result.

6. The immediate health assessment response system of Claim 1, wherein the test results include a quantitative result.
- 5 7. The immediate health assessment response system of Claim 6, wherein the quantitative result is a reaction rating.
8. The immediate health assessment response system of Claim 1, wherein a test line of at least one of the plurality of immunoassay test strips includes an antibody suitable for binding
10 with hCG.
9. The immediate health assessment response system of Claim 1, wherein a test line of at least one of the plurality of immunoassay test strips includes Zika virus antigen.
- 15 10. The immediate health assessment response system of Claim 1, wherein a test line of one of the plurality of immunoassay test strips includes Zika virus antigen and the test line of another one of the plurality of immunoassay test strips includes an antibody suitable for binding with hCG.
- 20 11. A method for providing an immediate health assessment response, comprising:
receiving at a server information from a mobile device regarding test results from a test performed using a testing device, a testing device having thereon an alignment target and having a plurality of immunoassay test strips;
receiving at the server an image from the mobile device;
25 processing at the server the image;
determining results based on pixel count and line intensity of a test line of each of the plurality of immunoassay test strips;
comparing the results of processing the image to a control for each test line of each of the plurality of immunoassay test strips; and
30 providing a risk indicator, wherein the risk indicator alerts a user to seek medical attention immediately.
12. The method of Claim 11, further comprising binding antigens or antibodies of an immune complex to antigens or antibodies included on a control line of a membrane strip.

13. The method of Claim 12, wherein the control line serves as a control.
14. The method of Claim 13, wherein the control is a dataset from previously conducted
5 tests stored on a database and accessed by a software application.
15. The method of Claim 11, wherein the test results include a qualitative result.
16. The method of Claim 11, wherein the test results include a quantitative result.
10
17. The method of Claim 16, wherein the quantitative result is a reaction rating.
18. The method of Claim 11, wherein a test line of at least one of the plurality of
immunoassay test strips includes an antibody suitable for binding with hCG.
15
19. The method of Claim 11, wherein a test line of at least one of the plurality of
immunoassay test strips includes Zika virus antigen.
20. The method of Claim 11, wherein a test line of one of the plurality of immunoassay
20 test strips includes Zika virus antigen and the test line of another one of the plurality of
immunoassay test strips includes an antibody suitable for binding with hCG.

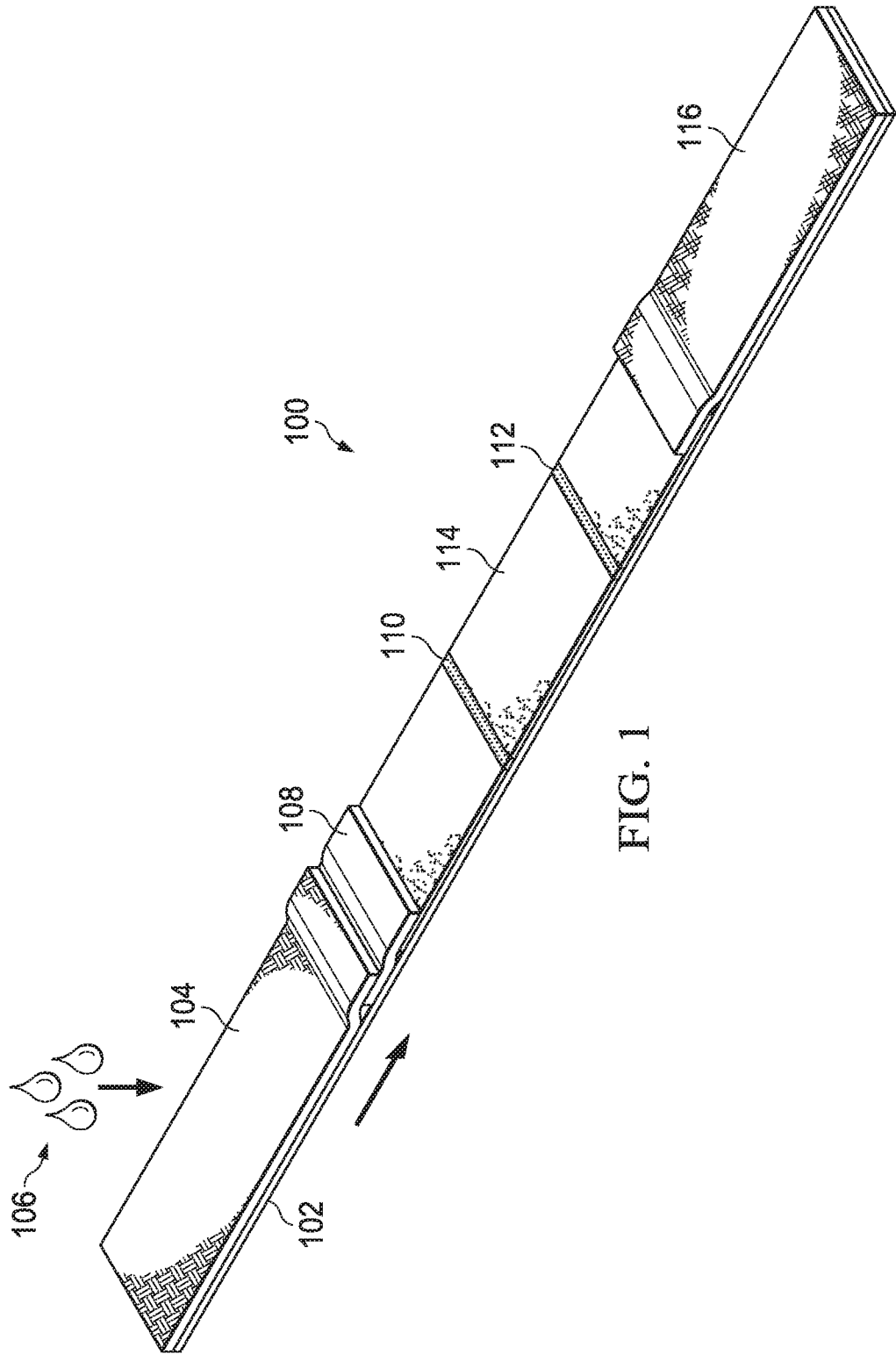

FIG. 1

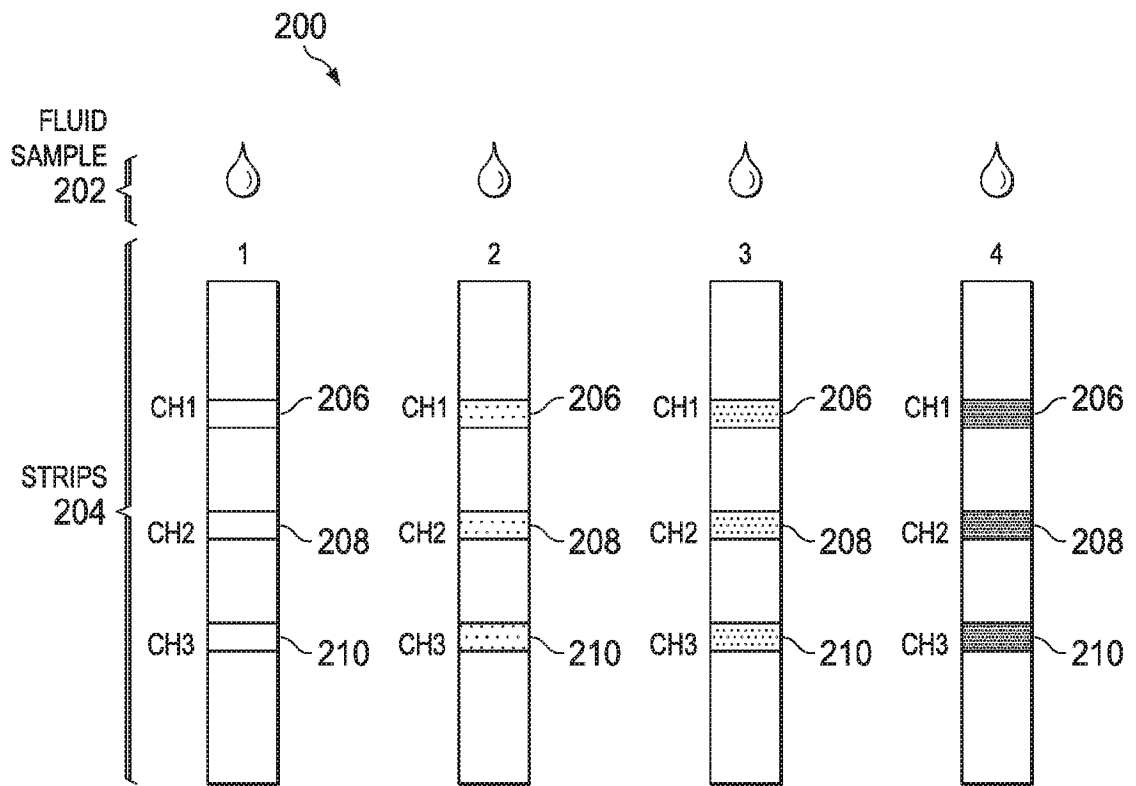

FIG. 2

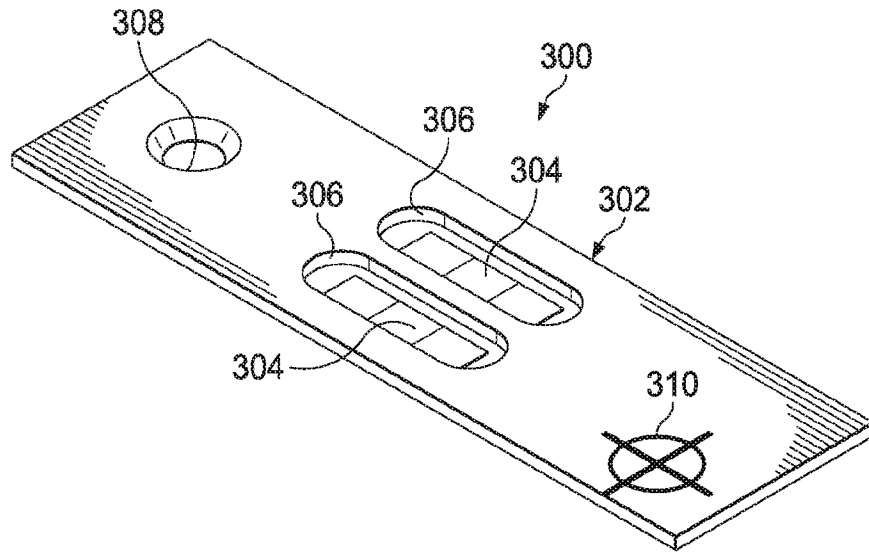

FIG. 3

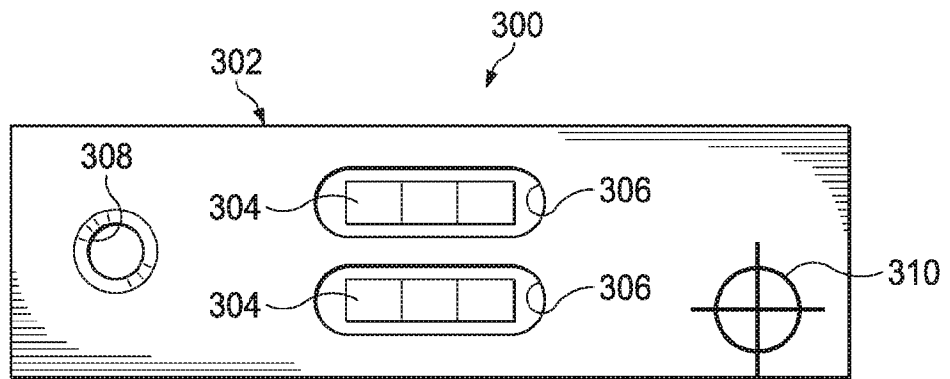

FIG. 4

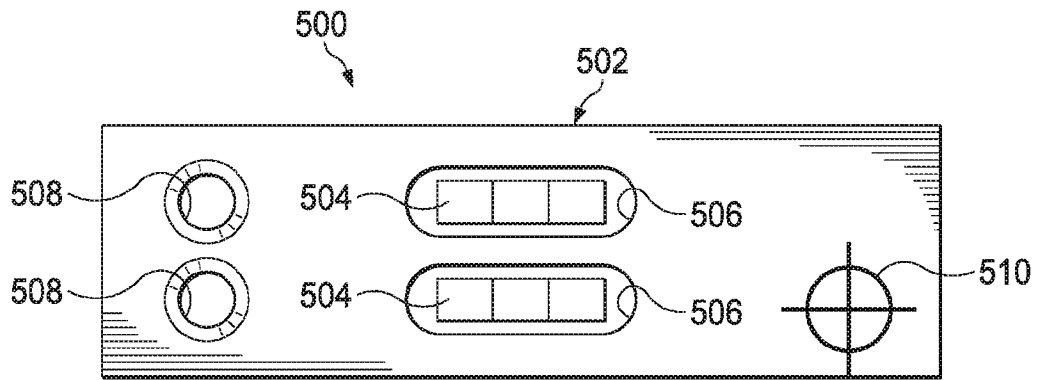

FIG. 5

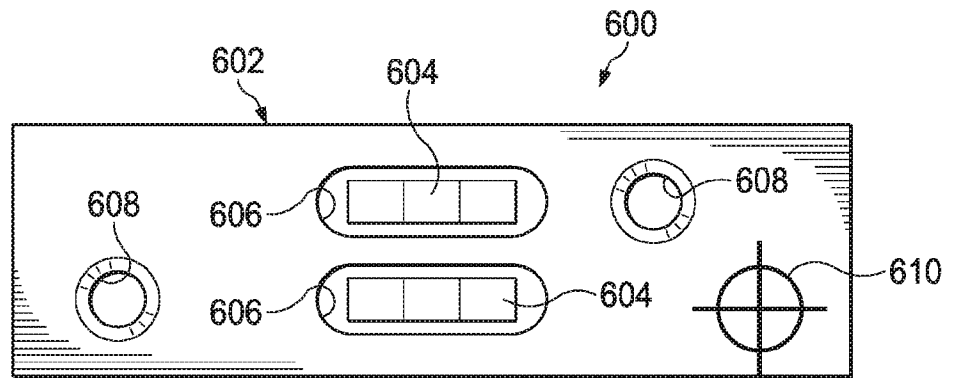

FIG. 6

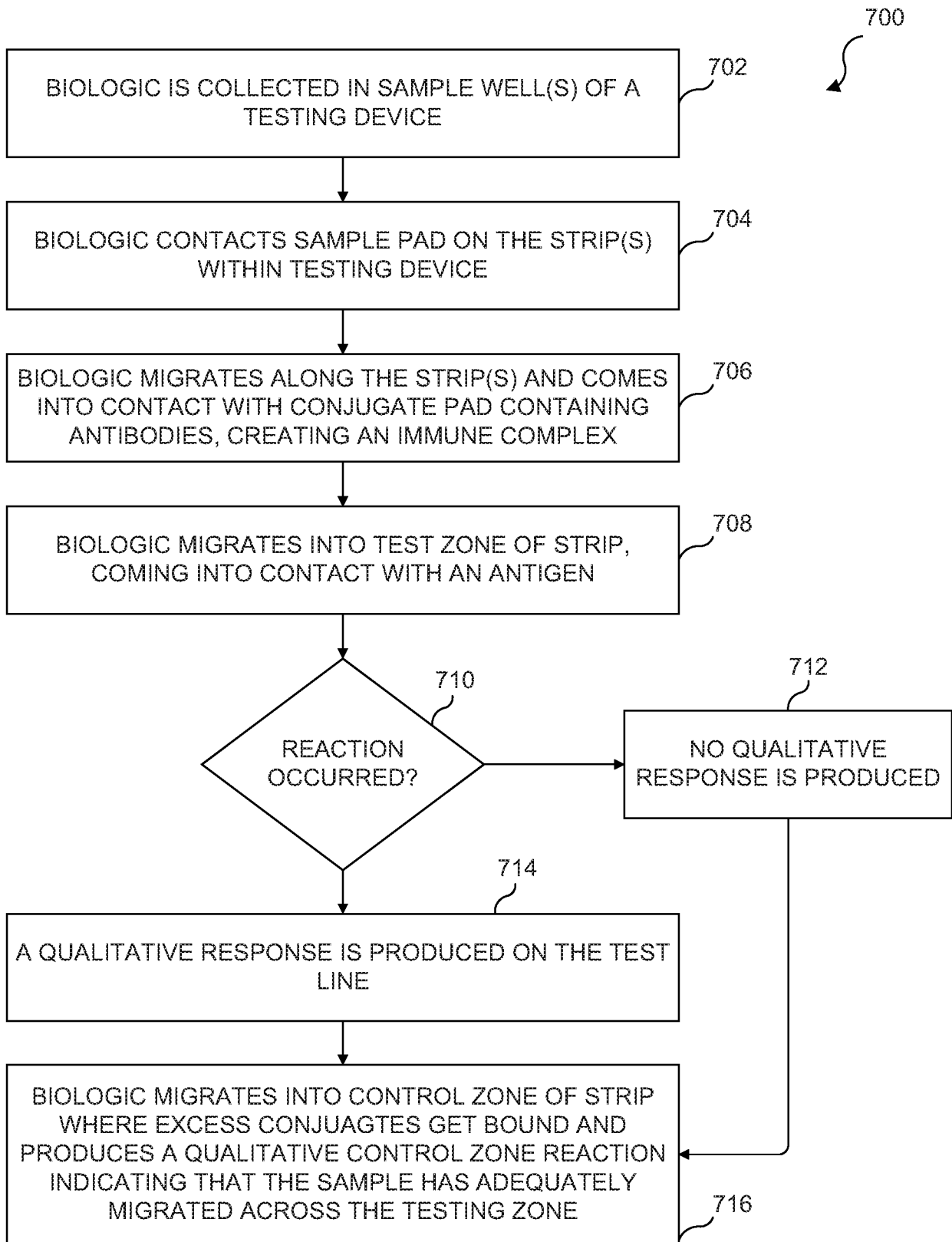

FIG. 7

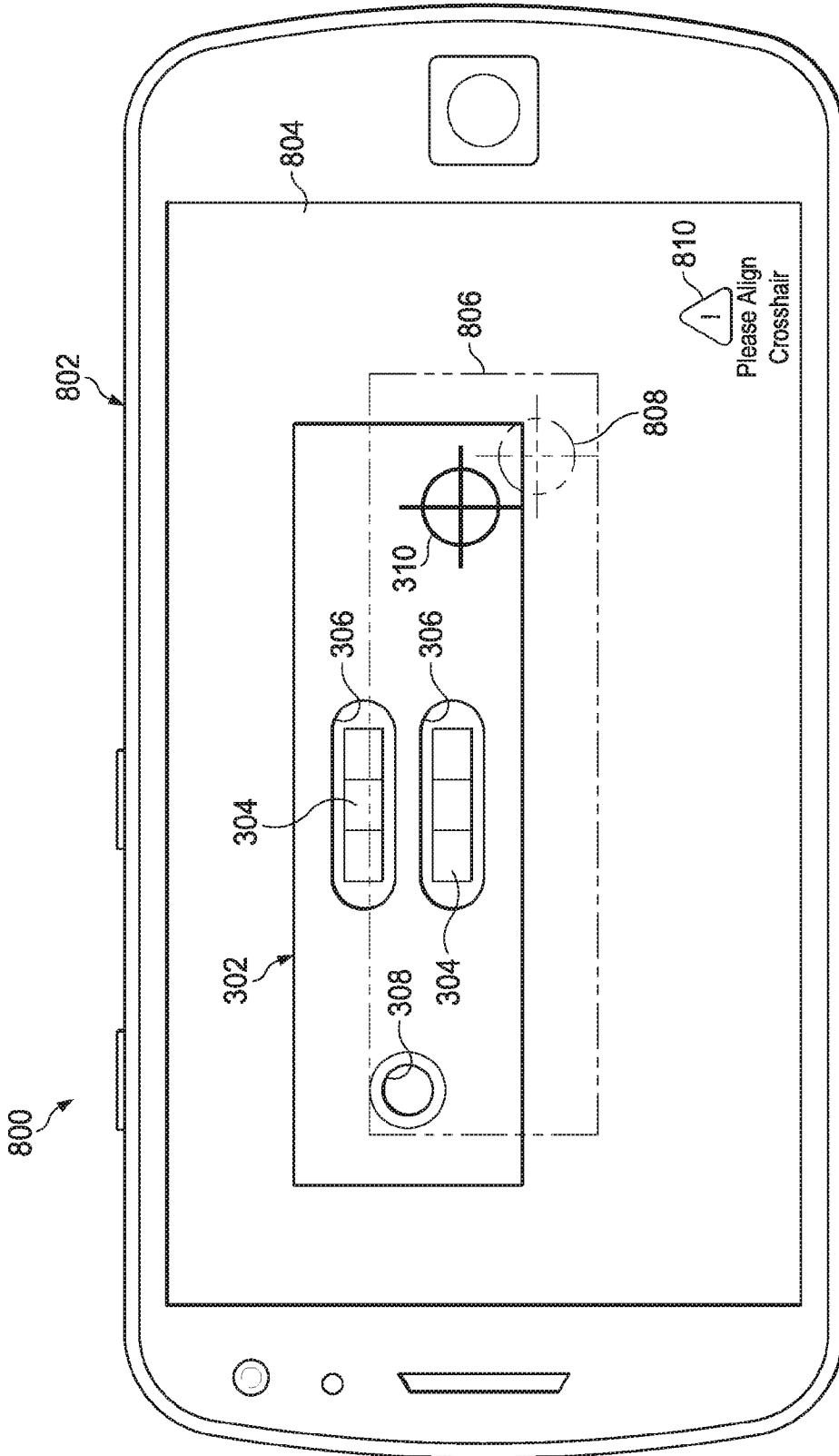

FIG. 8A

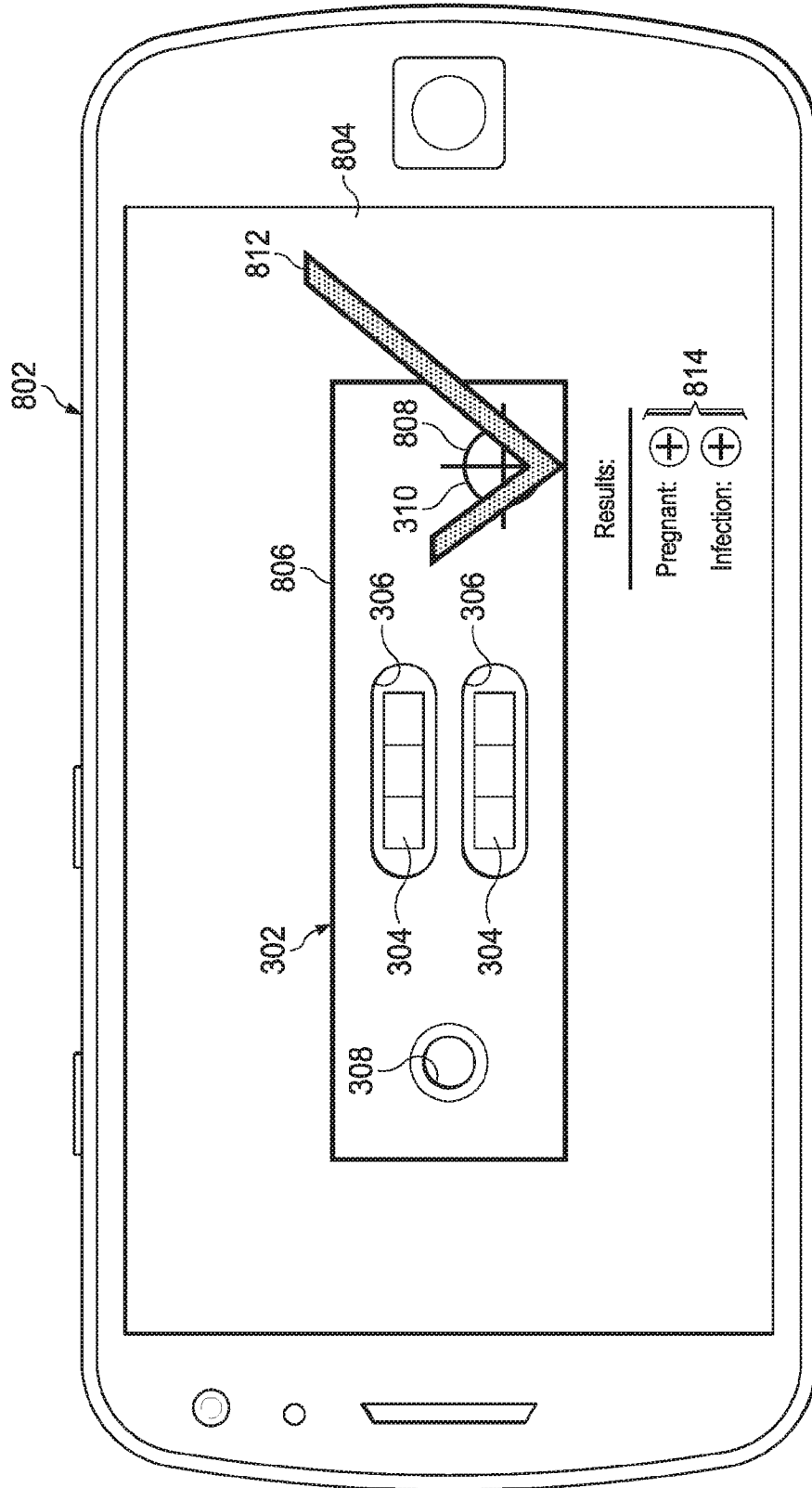

FIG. 8B

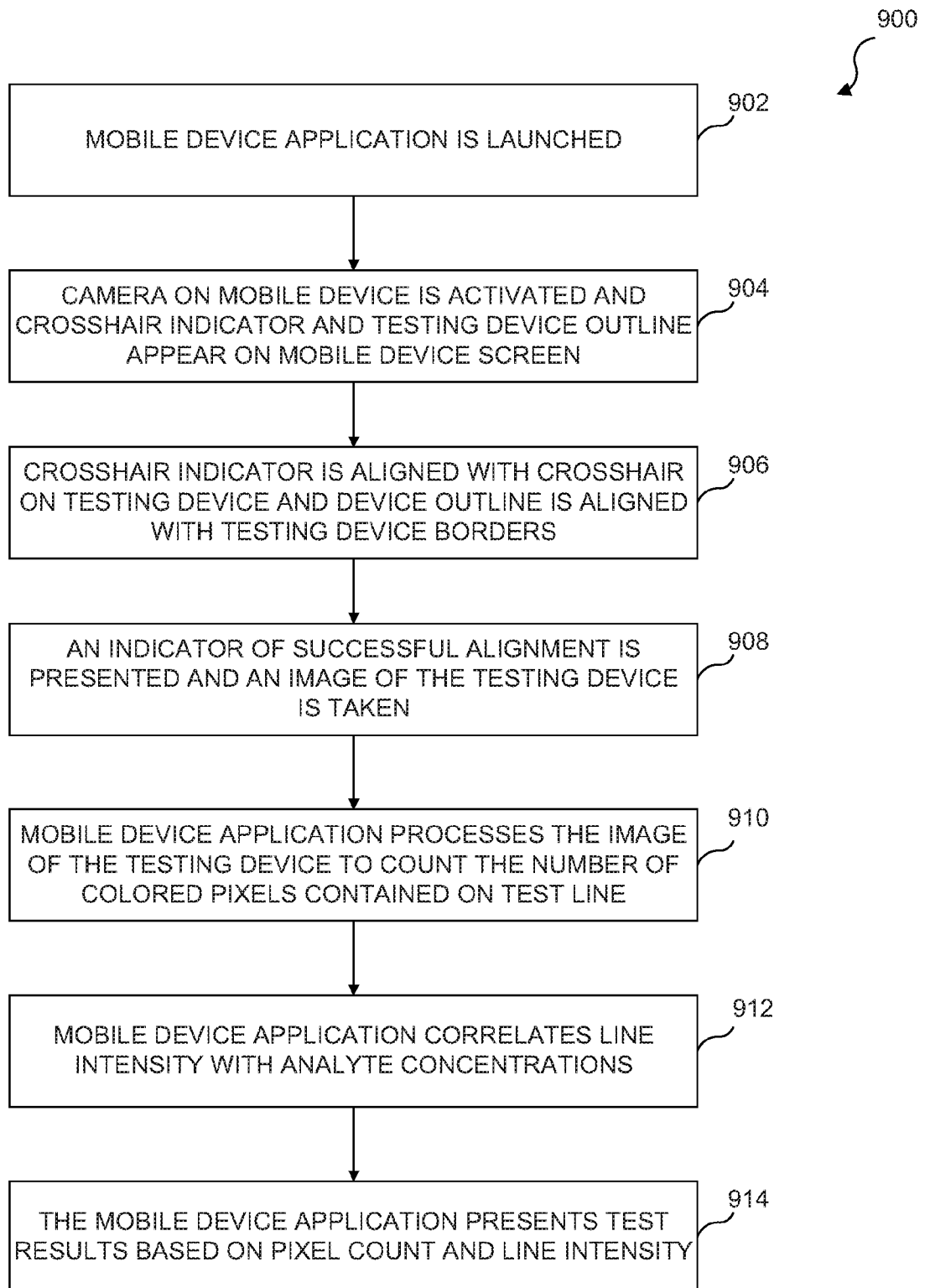

FIG. 9

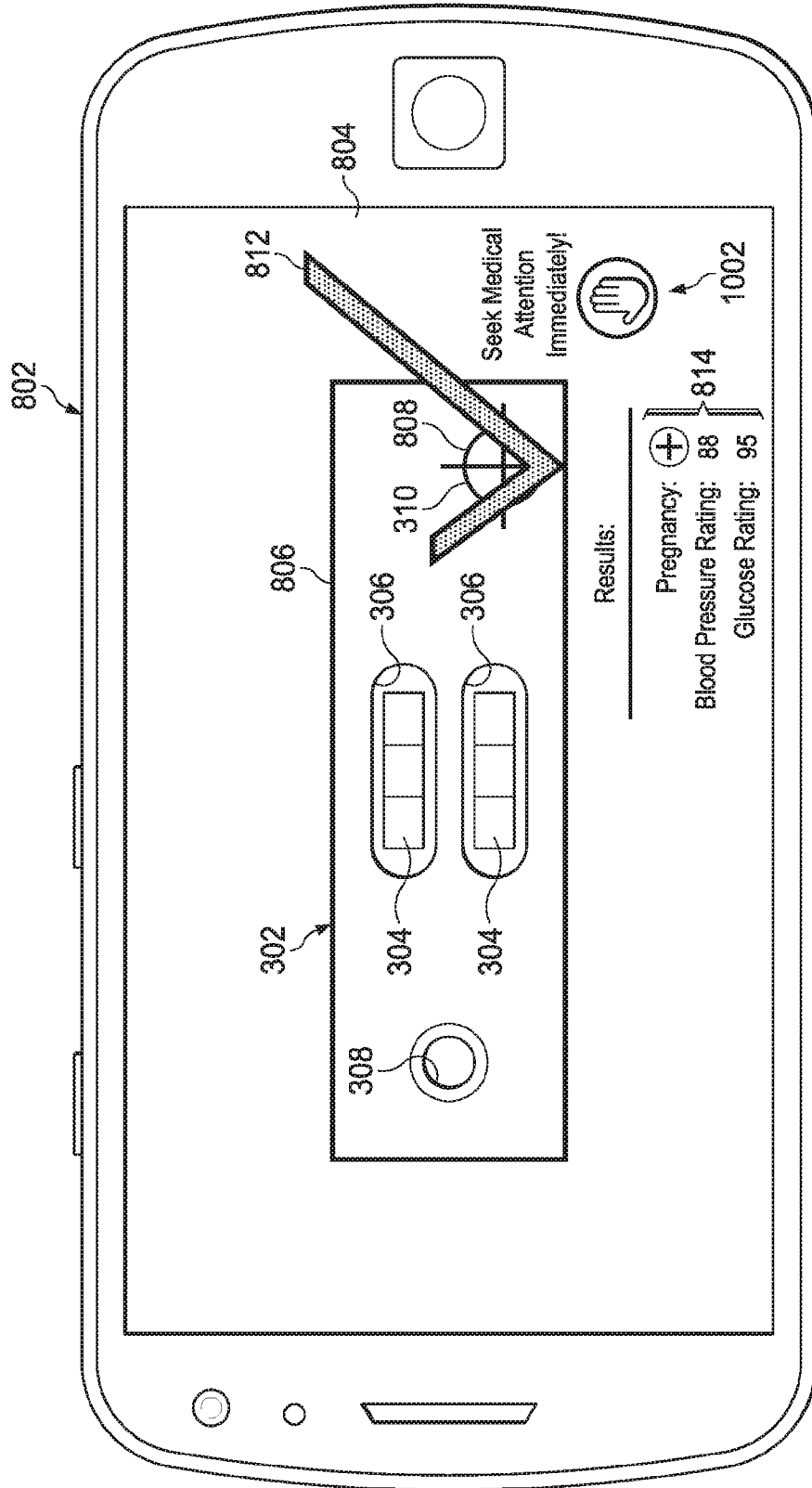

FIG. 10

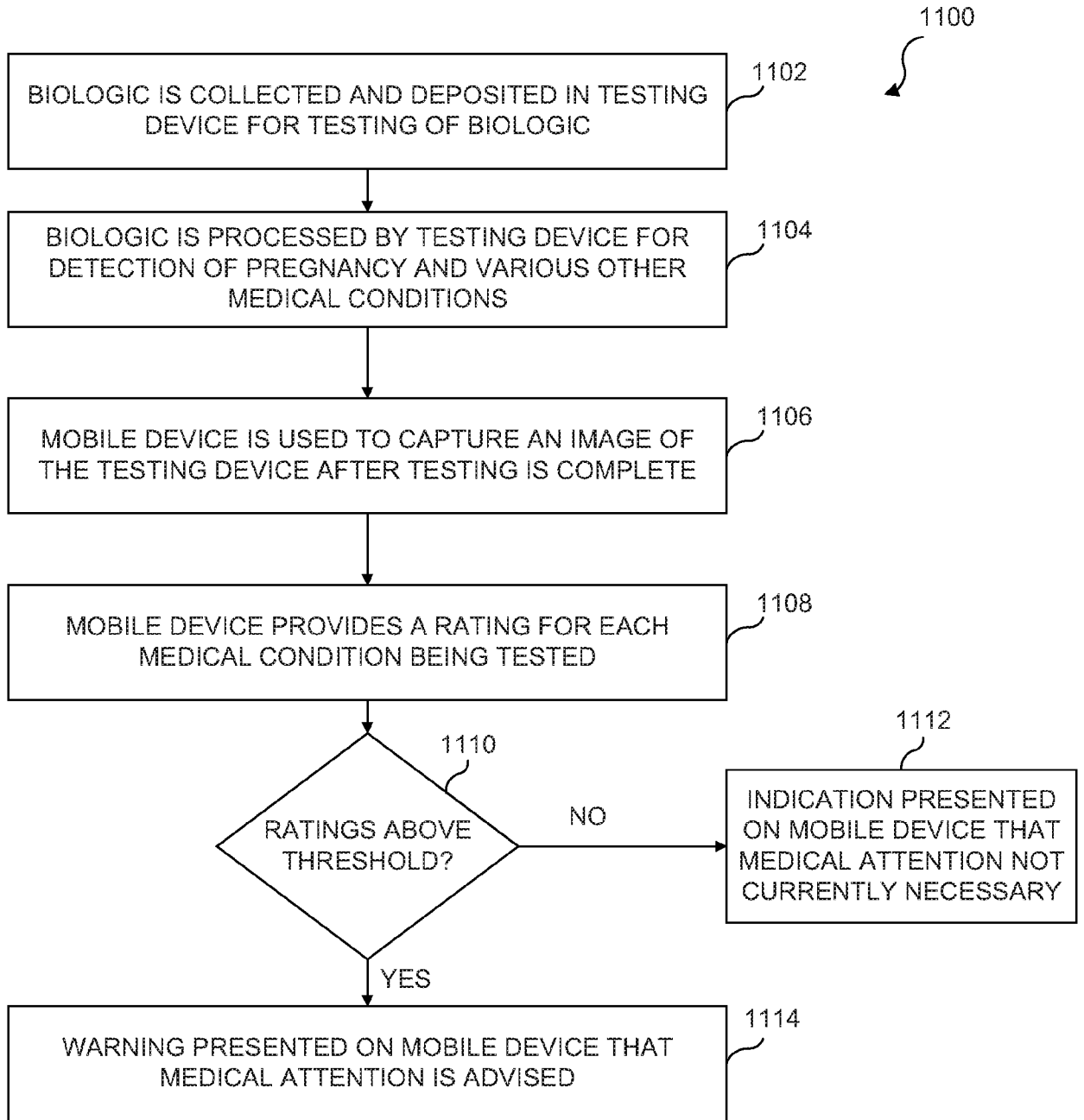

FIG. 11

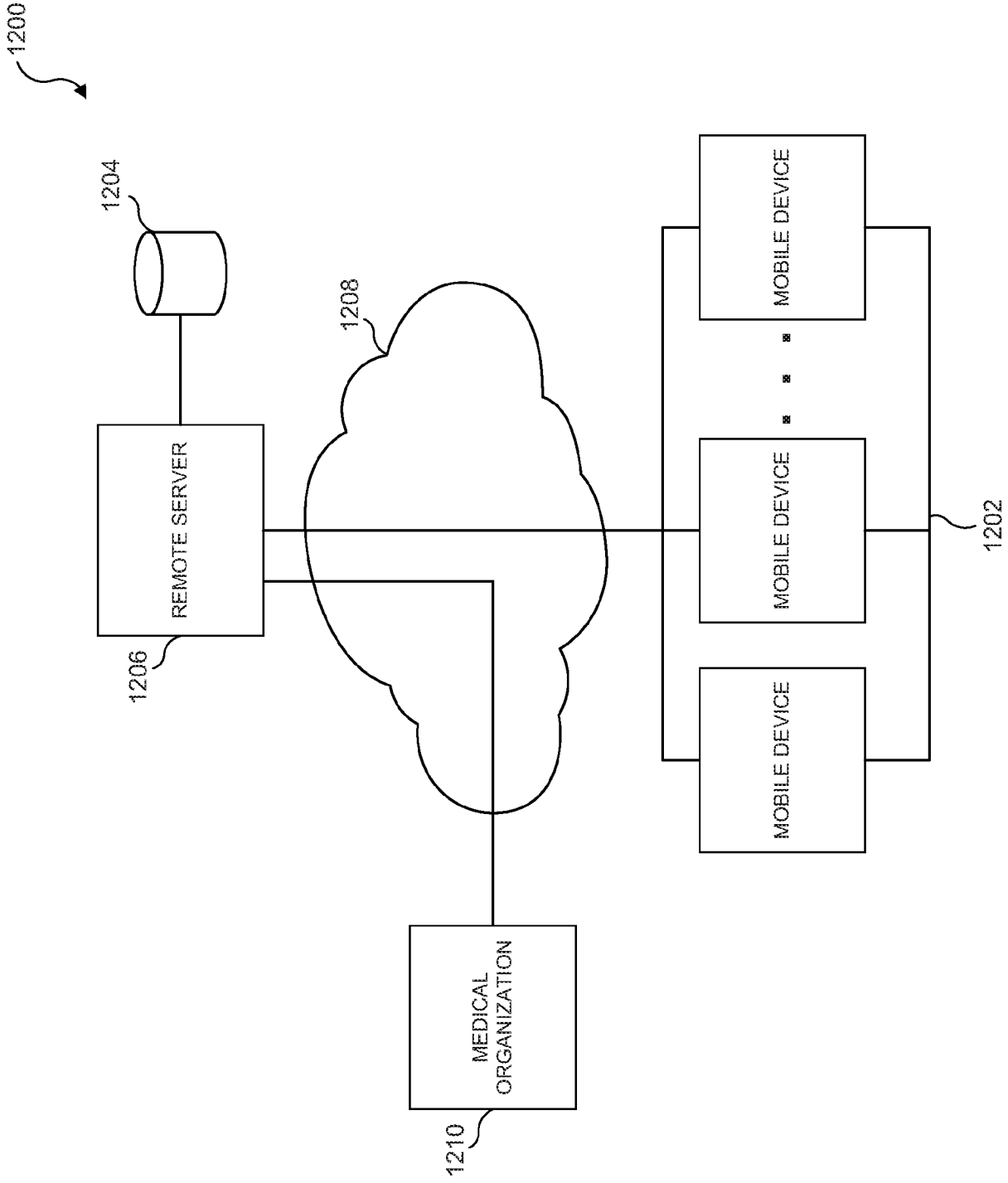

FIG. 12

1300

BIOLOGIC ID # 2402	
BIOLOGIC TYPE	BLOOD
PREGNANCY RATING	99
ZIKA INFECTION RATING	75
GLUCOSE RATING	10

1302

1304

1304

FIG. 13

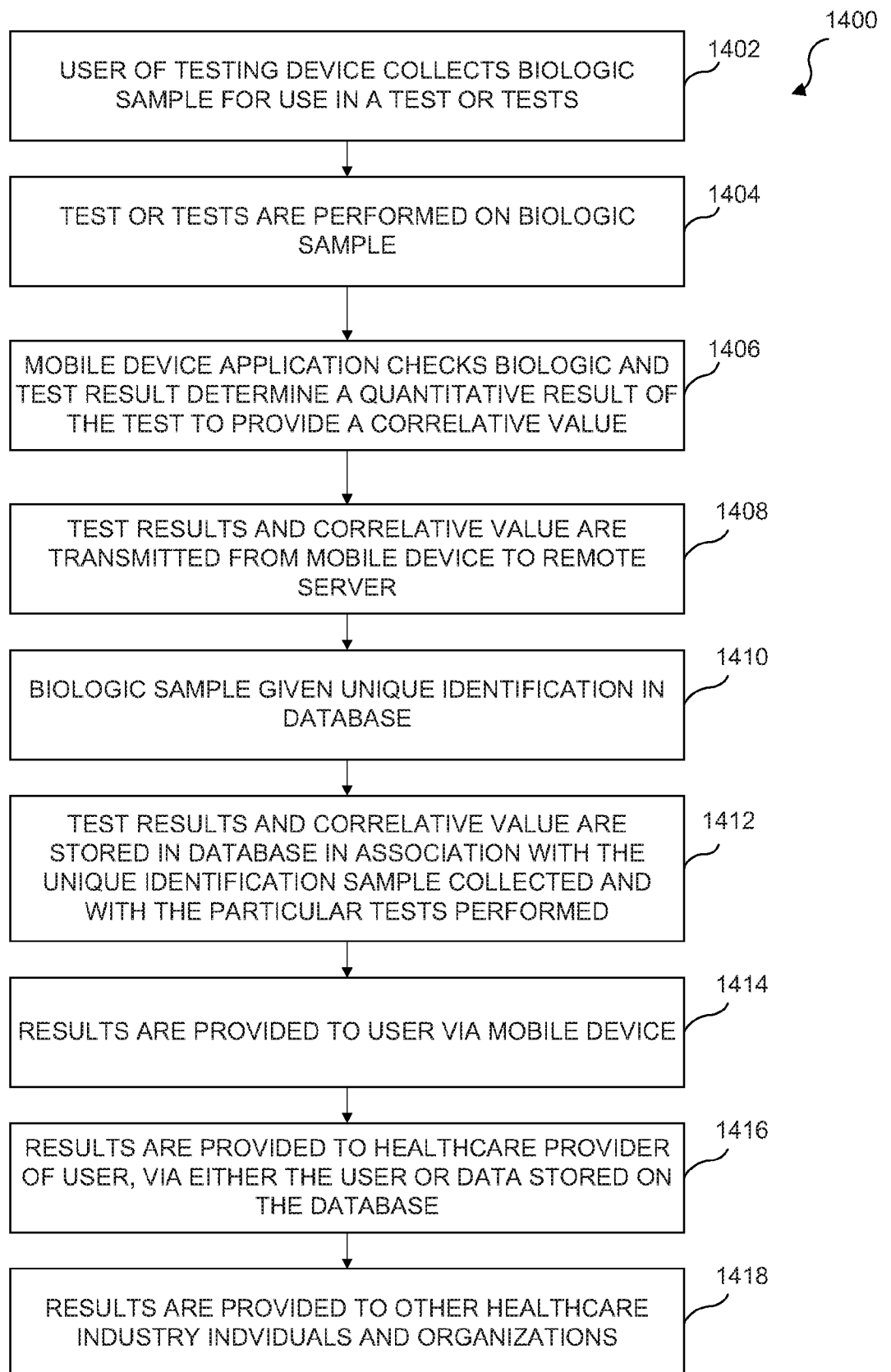
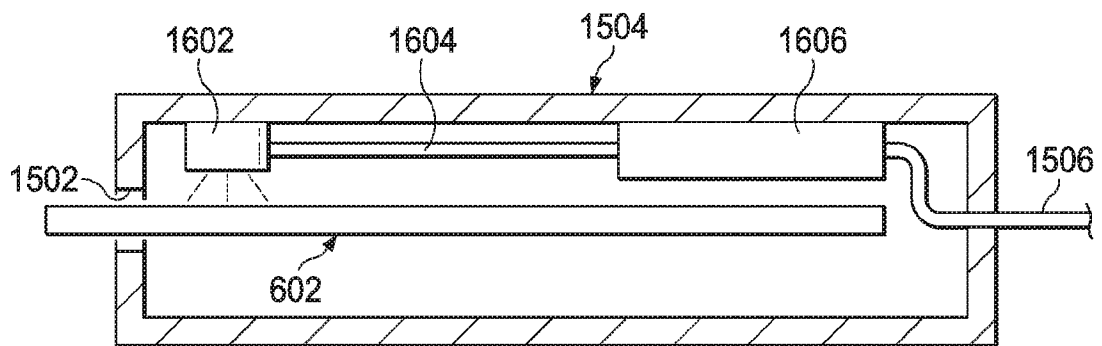
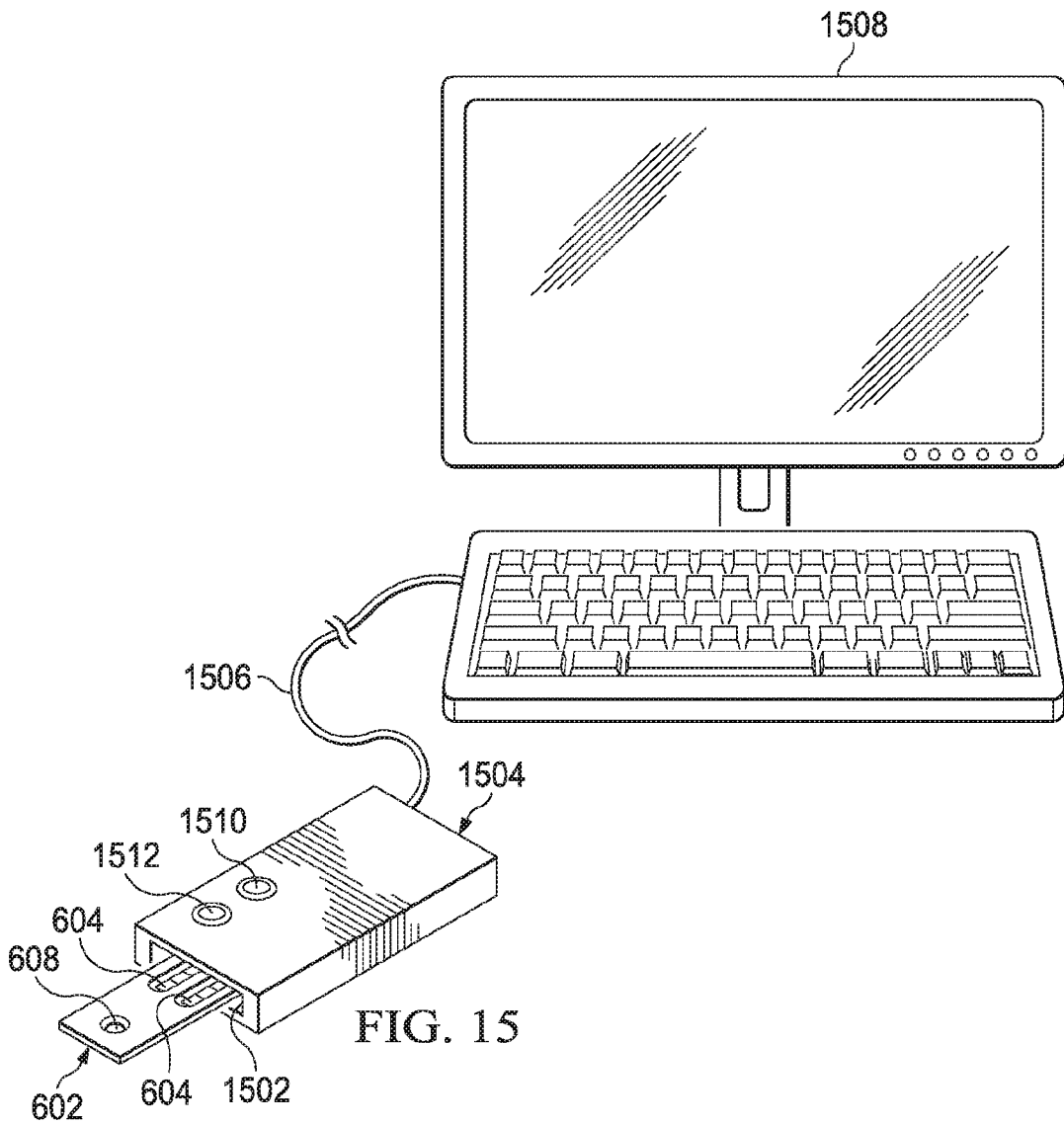

FIG. 14



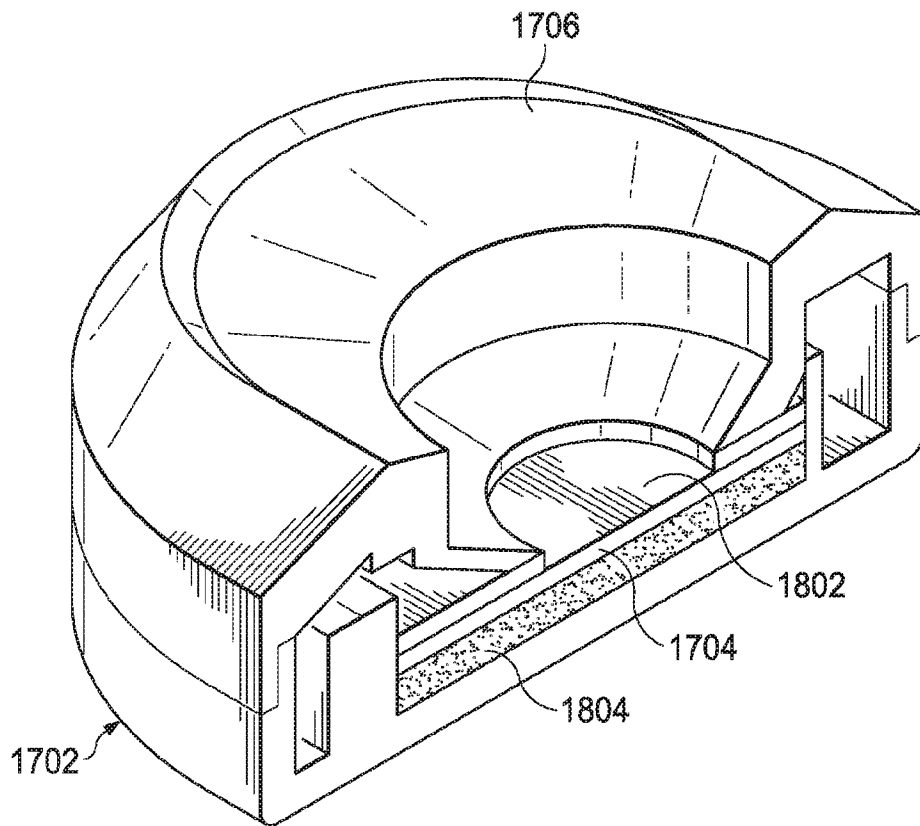
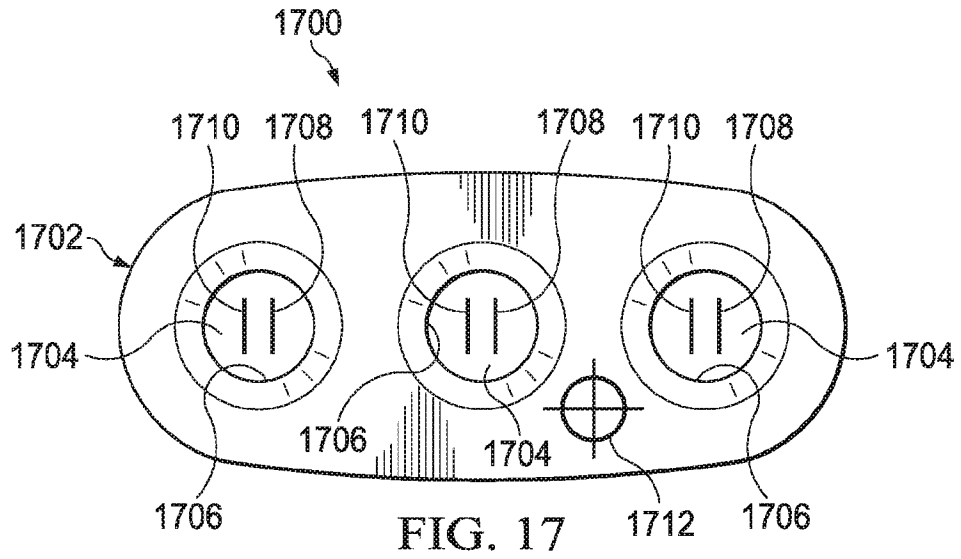

FIG. 18

INTERNATIONAL SEARCH REPORT

International application No.

PCT/US17/57041

A. CLASSIFICATION OF SUBJECT MATTER
 IPC - G01N 21/78; G01N 33/50, 33/53 (2017.01)
 CPC - G01N 21/78; G01N 33/53; G01N 35/00009

According to International Patent Classification (IPC) or to both national classification and IPC

B. FIELDS SEARCHED

Minimum documentation searched (classification system followed by classification symbols)
 See Search History document

Documentation searched other than minimum documentation to the extent that such documents are included in the fields searched
 See Search History document

Electronic data base consulted during the international search (name of data base and, where practicable, search terms used)
 See Search History document

C. DOCUMENTS CONSIDERED TO BE RELEVANT

Category*	Citation of document, with indication, where appropriate, of the relevant passages	Relevant to claim No.
X	WO 2013/158504 A1 (EHRENKRANZ, JRL) 24 October 2013; paragraphs [0006], [0033]-[0037], [0041]-[0043], [0054]-[0056], [0068], [0077], [0082]-[0091]; figures 1, 2A, 3A, 6	1-7, 11-17 ----- 8-10, 18-20
Y	US 2013/0161190 A1 (ABBOTT POINT OF CARE INC.) 27 June 2013; paragraph [0016]	8, 10, 18, 20
Y	ACHARYA, D et al. "An ultrasensitive electrogenerated chemiluminescence-based immunoassay for specific detection of Zika virus" Scientific Reports 6, Article number: 32227 (2016); doi:10.1038/srep32227 from https://www.nature.com/articles/srep32227 downloaded 23 November 2017; published on-line August 2016; abstract; page 2, paragraph 2	9-10, 19-20
A	US 2014/0072189 A1 (JENA, S et al.) 13 March 2014; entire document	1-20

Further documents are listed in the continuation of Box C.

See patent family annex.

* Special categories of cited documents:

"A" document defining the general state of the art which is not considered to be of particular relevance

"E" earlier application or patent but published on or after the international filing date

"L" document which may throw doubts on priority claim(s) or which is cited to establish the publication date of another citation or other special reason (as specified)

"O" document referring to an oral disclosure, use, exhibition or other means

"P" document published prior to the international filing date but later than the priority date claimed

"T" later document published after the international filing date or priority date and not in conflict with the application but cited to understand the principle or theory underlying the invention

"X" document of particular relevance; the claimed invention cannot be considered novel or cannot be considered to involve an inventive step when the document is taken alone

"Y" document of particular relevance; the claimed invention cannot be considered to involve an inventive step when the document is combined with one or more other such documents, such combination being obvious to a person skilled in the art

"&" document member of the same patent family

Date of the actual completion of the international search

27 November 2017 (27.11.2017)

Date of mailing of the international search report

14 DEC 2017

Name and mailing address of the ISA/

Mail Stop PCT, Attn: ISA/US, Commissioner for Patents
 P.O. Box 1450, Alexandria, Virginia 22313-1450
 Facsimile No. 571-273-8300

Authorized officer

Shane Thomas

PCT Helpdesk: 571-272-4300
 PCT OSP: 571-272-7774