

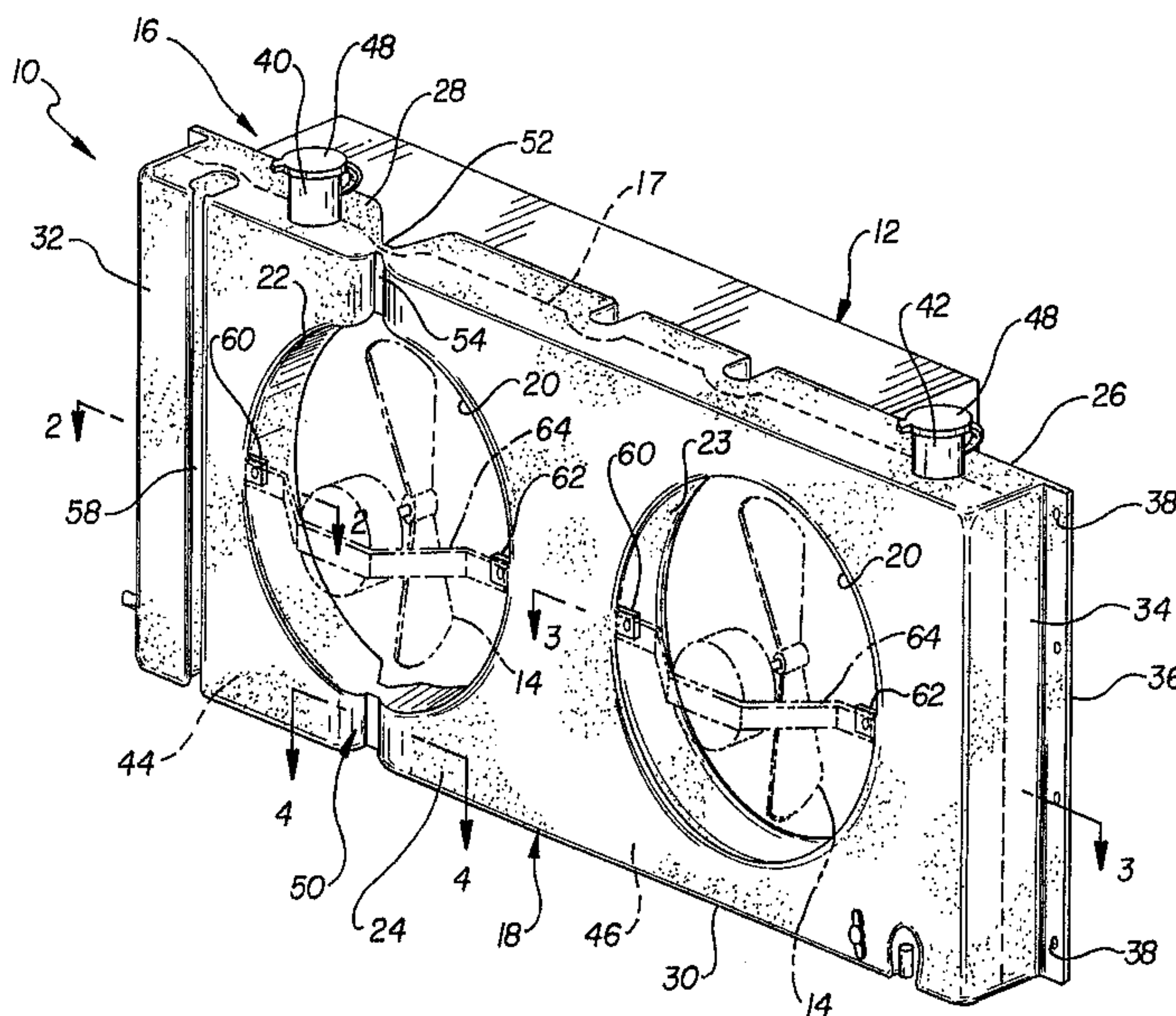

(86) Date de dépôt PCT/PCT Filing Date: 1997/01/29
 (87) Date publication PCT/PCT Publication Date: 1997/08/28
 (45) Date de délivrance/Issue Date: 2005/05/10
 (85) Entrée phase nationale/National Entry: 1998/08/21
 (86) N° demande PCT/PCT Application No.: US 1997/001390
 (87) N° publication PCT/PCT Publication No.: 1997/031182
 (30) Priorité/Priority: 1996/02/23 (605,981) US

(51) Cl.Int.⁶/Int.Cl.⁶ F04D 29/60, F04D 29/40, F01P 3/00
 (72) Inventeur/Inventor:
 PLANT, WILLIAM D., US
 (73) Propriétaire/Owner:
 MCCORD WINN TEXTRON INC., US
 (74) Agent: MACRAE & CO.

(54) Titre : AMENAGEMENT DE LA BUSE ET DU RECEPTACLE DU VENTILATEUR
 (54) Title: FAN SHROUD AND RECEPTACLE ARRANGEMENT



(57) **Abrégé/Abstract:**

A fan shroud and receptacle arrangement for use adjacent a vehicle radiator (12) and around one or more engine cooling fans (14). The arrangement includes a shaped hollow body (18) of a predetermined depth and having a front face (24), a rear face (26), a top wall (28), a bottom wall (30), oppositely disposed side walls (32 and 34), at least one opening (20) formed through the body (18) with a cylindrical wall (22 or 23) therearound. Oppositely disposed recesses (50 and 52) are formed in the front and rear faces (24 and 26) to form a wall (54) for dividing the hollow body (18) into two or more internal chambers (44 and 46). Filler necks (40 and 42) and/or other openings are formed in the top wall (28) for communicating with the two or more internal chambers (44 and 46).



PCT

WORLD INTELLECTUAL PROPERTY ORGANIZATION
International Bureau

INTERNATIONAL APPLICATION PUBLISHED UNDER THE PATENT COOPERATION TREATY (PCT)

(51) International Patent Classification ⁶ : F01P 9/04	A1	(11) International Publication Number: WO 97/31182
		(43) International Publication Date: 28 August 1997 (28.08.97)

(21) International Application Number: PCT/US97/01390

(22) International Filing Date: 29 January 1997 (29.01.97)

(30) Priority Data:
08/605,981 23 February 1996 (23.02.96) US(71) Applicant: McCORD WINN TEXTRON INC. [US/US]; 645
Harvey Road, Manchester, NH 03103 (US).(72) Inventor: PLANT, William, D.; 103 Cane Brake Drive,
Anderson, SC 29621 (US).(74) Agent: EVANS, John, C.; Reising, Ethington, Barnard & Perry,
P.O. Box 4390, Troy, MI 48099-4390 (US).(81) Designated States: CA, JP, MX, European patent (AT, BE,
CH, DE, DK, ES, FI, FR, GB, GR, IE, IT, LU, MC, NL,
PT, SE).**Published***With international search report.
With amended claims.*

(54) Title: FAN SHROUD AND RECEPTACLE ARRANGEMENT

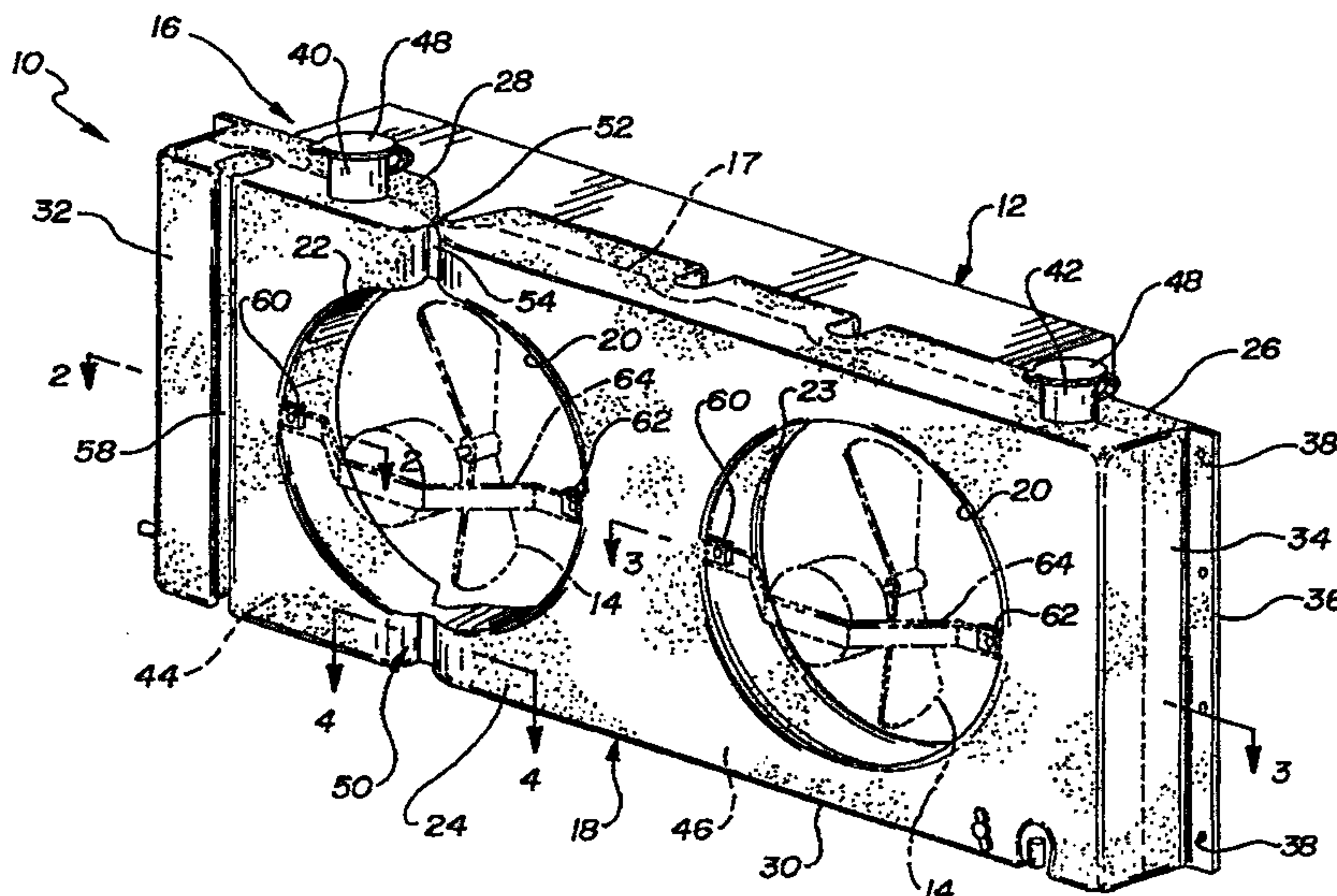
**(57) Abstract**

A fan shroud and receptacle arrangement for use adjacent a vehicle radiator (12) and around one or more engine cooling fans (14). The arrangement includes a shaped hollow body (18) of a predetermined depth and having a front face (24), a rear face (26), a top wall (28), a bottom wall (30), oppositely disposed side walls (32 and 34), at least one opening (20) formed through the body (18) with a cylindrical wall (22 or 23) therearound. Oppositely disposed recesses (50 and 52) are formed in the front and rear faces (24 and 26) to form a wall (54) for dividing the hollow body (18) into two or more internal chambers (44 and 46). Filler necks (40 and 42) and/or other openings are formed in the top wall (28) for communicating with the two or more internal chambers (44 and 46).

Another object of the invention is to provide a one-piece fan shroud arrangement wherein compartments, such as a radiator fluid overflow compartment, a windshield washer fluid compartment, and a headlamp washer fluid compartment, are integrally contained around side surfaces of at least one fan shroud formed as openings through a blow molded receptacle.

Another object of the invention is to provide a compact, one-piece fan shroud and dual fluid receptacle arrangement, resulting in: (1) the elimination of the need for space and fastening means for three separate components; (2) cost savings by virtue of having eliminated the need to manufacture three separate parts, while utilizing heretofore unused surrounding surface areas of the fan shroud; (3) the possible elimination of the need for retooling for different designs for specific vehicle models; (4) larger capacity windshield washer fluid and/or headlamp washer fluid compartments; (5) a radially and axially rigid structure; and (6) improved aerodynamic surface areas around the fan opening to allow higher, more efficient air flow through the fan shroud and receptacle assembly.

25

These and other objects and advantages of the invention will become apparent when reference is made to the following drawings and the accompanying description.

30

Brief Description Of The Drawings

Figure 1 illustrates a perspective view of a blow molded fan shroud embodying the invention;

Figures 2, 3 and 4 are cross-sectional views taken along the planes of the lines 2-2, 3-3, and 4-4, respectively, of Figure 1, and looking in the directions of the arrows; and

5 Figure 5 is a perspective view of an alternate embodiment of the invention.

Best Mode For Carrying The Invention

10 Referring now to the drawings in greater detail, Figure 1 illustrates an automotive engine cooling system 10, including a radiator 12, two engine cooling fans 14 shown in phantom, and a blow molded fan shroud arrangement 16. The latter arrangement 16 is
15 blow molded (the mold parting line 17 is shown in phantom) to include a rectangular hollow body 18 of predetermined height, width and depth, and having dual openings 20 with respective cylindrical walls 22 and 23 formed therethrough and adapted to surround the outer
20 peripheral paths of the two fans 14.

More specifically, the body 18 includes a front face 24, a rear face 26, a top wall 28, a bottom wall 30, and oppositely disposed side walls 32 and 34.

25 A flange or tab 36 is formed on an edge of each side wall 32 and 34. The flanges 36 include spaced mounting holes 38 adapted to accommodate fasteners 39 to mount the body 18 on the radiator 12 of the vehicle
30 involved, as shown in Figure 3.

A pair of filler necks 40 and 42 are formed at spaced-apart locations along the top wall 28, for communicating with respective chambers 44 and 46 formed

within the hollow body 18, adjacent and around the cylindrical walls 22, as will be explained. A pair of removable caps 48 are mounted on the filler necks 40 and 42.

5

Oppositely disposed vertically oriented recesses 50 and 52 are formed in the respective front and rear faces 24 and 26 to provide walls 54 (Figure 1) and 56 (Figure 4) adjacent upper and lower portions of the cylindrical wall 22, serving to separate the chambers 44 and 46.

Additional recesses, such as the vertical recess 58 (Figures 1 and 2), may be formed in the front face 24 to accommodate wire harnesses, hoses, or the like.

Perforated tabs 60 and 62 are formed on opposite edges of each opening 20 to accommodate the mounting of fan assembly support brackets 64, as shown in Figures 2 and 3. A U-nut clip 66 is mounted around each tab 60 and 62, and a fastener 68 is mounted through aligned holes 70 formed in the clip 66 and each tab 60 and 62.

25

As shown in Figure 3, a fan motor 72 is secured by suitable fasteners 74 to the inner surface of a U-shaped portion 76 of the support bracket 64.

30

The chamber 44 is enclosed by the front and rear faces 24 and 26, the top wall 28, the side wall 32, the bottom wall 30, the walls of the recesses 50 and 52 adjacent the lower recessed wall 56 (Figure 4), the cylindrical wall 22 (Figure 2), and the walls of the

recesses 50 and 52 adjacent the upper recessed wall 54 (Figure 1).

The chamber 46 encompasses a larger volume than the chamber 44, and is enclosed by the front and rear faces 24 and 26, top wall 28, the side wall 34, the bottom wall 30, the walls of the recesses 50 and 52 adjacent the lower separating recessed wall 56 (Figure 4), the cylindrical wall 22, and the walls of the recesses 50 and 52 adjacent the upper separating recessed wall 54, while completely surrounding the cylindrical wall 23.

As represented in phantom in Figure 4, the mold 80 design incorporates "tacks offs" to separate the chambers 44 and 46 in the molding process.

As shown in Figure 5, in lieu of the separately attached fan assembly mounting bracket 64 shown in Figure 3, an integral frame structure 82 may be compression molded during the blow molding process.

Industrial Applicability

It should be apparent that the invention provides a compact cooling system structure which eliminates the need for space and fastening means for three separate components in the already crowded engine compartment of today's automobile. It provides substantial cost savings by virtue of having eliminated the need to manufacture and assemble three separate parts, while utilizing heretofore unused surface areas of the fan shroud.

Additionally, the invention may provide a standard or uniform structure which is unaffected by many new vehicular designs. Specifically, the shape of the compartments 44 and 46 need not be redesigned each time the fender wells and other interior parts are changed on at least some new vehicle models. Also, the integrally molded windshield washer fluid or headlamp washer fluid compartments may have a larger capacity than the previously employed separate containers.

10

Furthermore, the resultant structure is extremely rigid, both radially and axially, and damped by fluid in the receptacles, reducing vibration or excitation of the fan shroud caused by the rotating fan surrounded thereby, hence diminishing a possible source of bothersome noise.

15

It should be further apparent that the inventive fan shroud and receptacle arrangement could be formed by one-piece gas assist injection molding, as well as by blow molding.

20

It should be still further apparent that, in lieu of the integral frame structure 82 of Figure 5, and the separately attached fan assembly mounting bracket 64 and tabs 60 and 62 of Figure 3, the openings 20 are adaptable to having fans mounted therein which are belt-driven and attached to the motor.

25

While but one embodiment of the invention has been shown and described, other modifications thereof are possible within the scope of the following claims.

30

AMENDED CLAIMS

[received by the International Bureau on 18 July 1997 (18.07.97);
original claims 1 and 2 amended; remaining claims unchanged (2 pages)]

5

1. A fan shroud and receptacle arrangement for use adjacent a vehicle radiator and around one or more engine cooling fans, the arrangement comprising a shaped hollow body of a predetermined depth and having
10 a front face, a rear face spaced from said front face, a top wall, a bottom wall, oppositely disposed side walls, at least one opening formed through the body of a size to accommodate air flow through the vehicle radiator and having a cylindrical wall therearound, at
15 least one set of oppositely disposed recesses formed in the front and rear faces to form a wall for dividing the hollow body into two or more internal chambers, and openings formed in the body for communicating with the two or more internal chambers.

20

2. The fan shroud and receptacle arrangement described in claim 1, wherein the wall for dividing the hollow body into two or more internal chambers is formed above and below the cylindrical wall.

25

3. The fan shroud and receptacle arrangement described in claim 2, including two openings having cylindrical walls therearound.

30

4. The fan shroud and receptacle arrangement described in claim 3, wherein one chamber completely surrounds one cylindrical wall.

5. The fan shroud and receptacle arrangement
35 described in claim 1, and mounting tabs integrally formed on oppositely disposed sides of said at least

one opening adapted to receive a fan assembly mounting bracket.

6. The fan shroud and receptacle arrangement described in claim 1, wherein the hollow body is formed by blow molding.

7. The fan shroud and receptacle arrangement described in claim 6, and a frame structure adapted to support a fan motor and integrally formed on the hollow body during the blow molding.

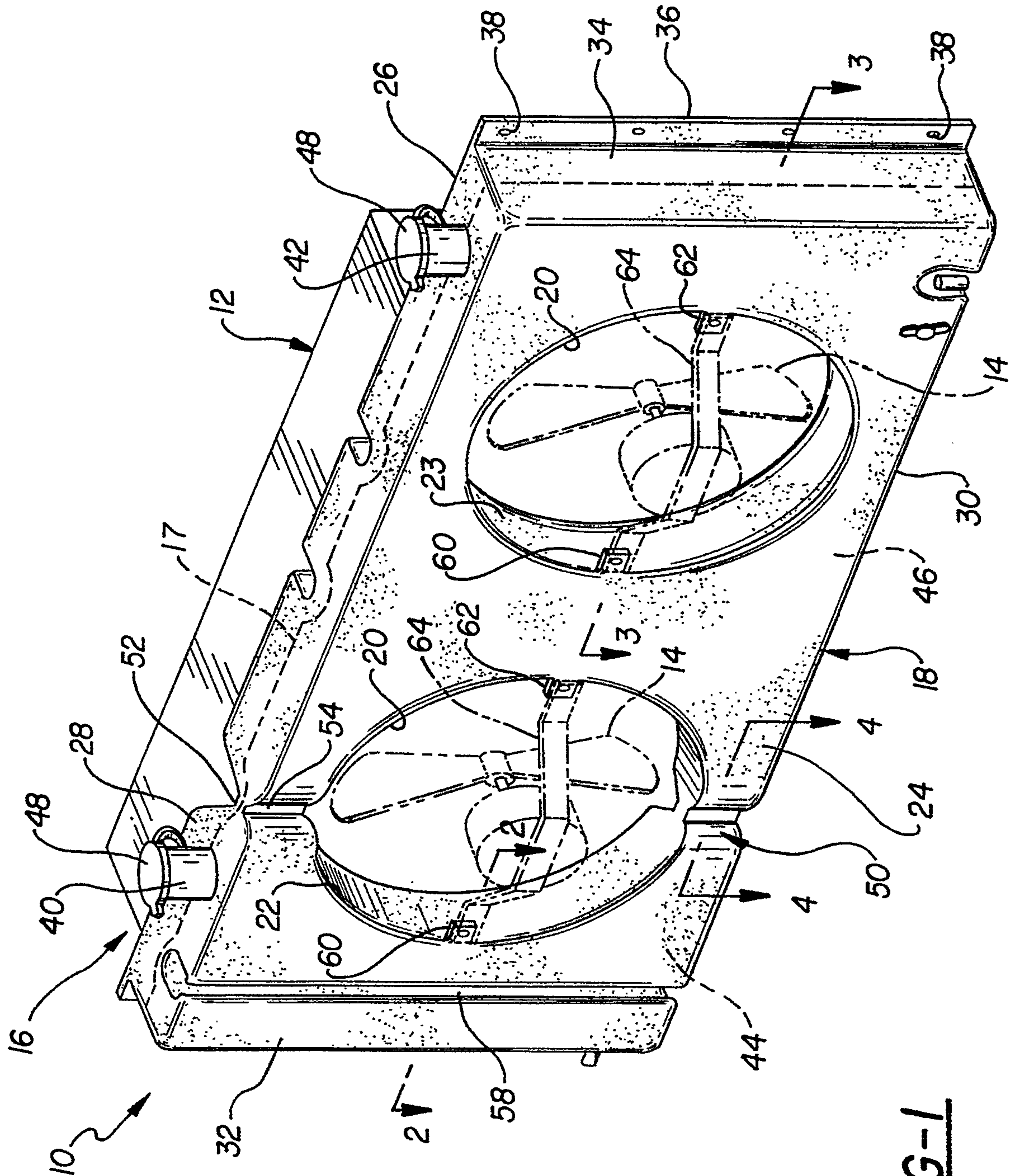

FIG-1

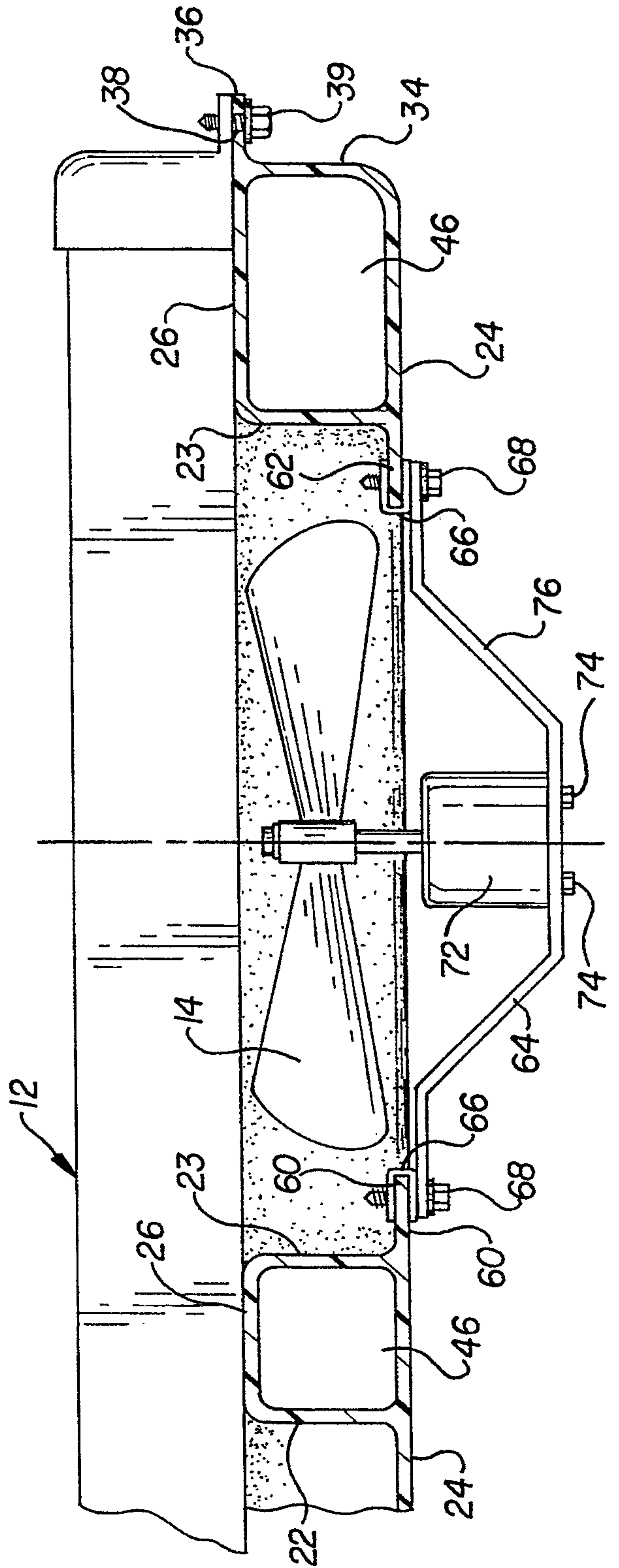
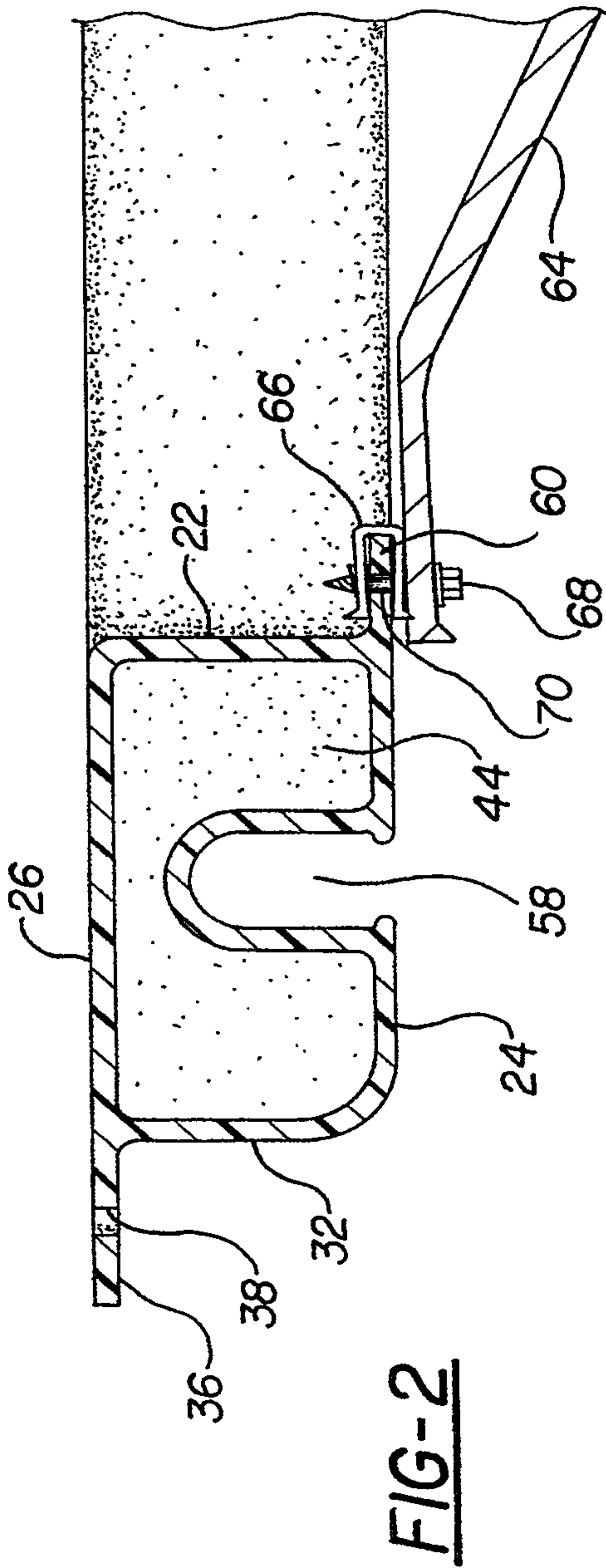

FIG-4

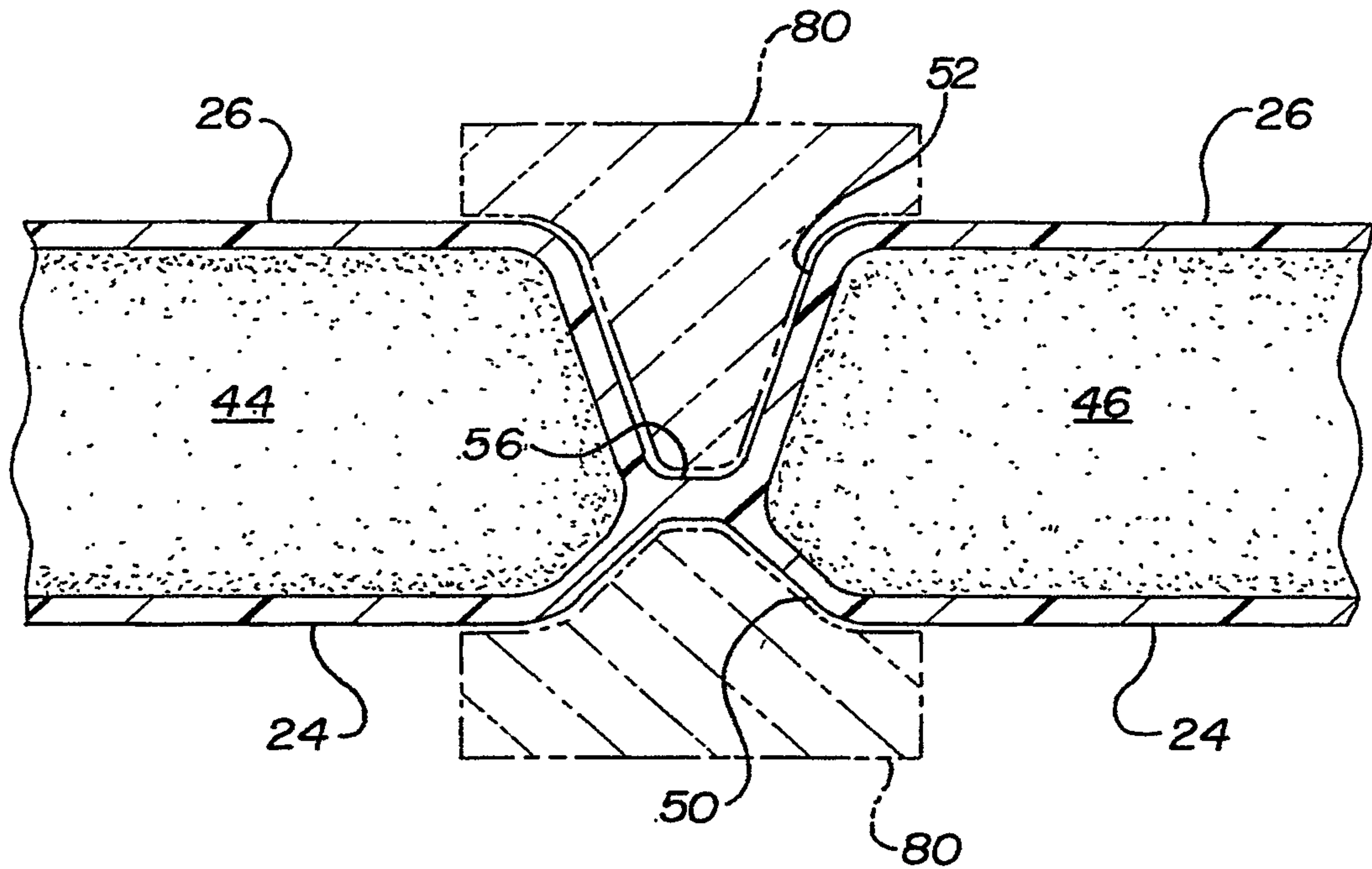

FIG-5

