

April 20, 1926.

1,582,010

H. A. HANSON

VALVE GRINDING CHUCK

Filed April 21, 1925

2 Sheets-Sheet 2

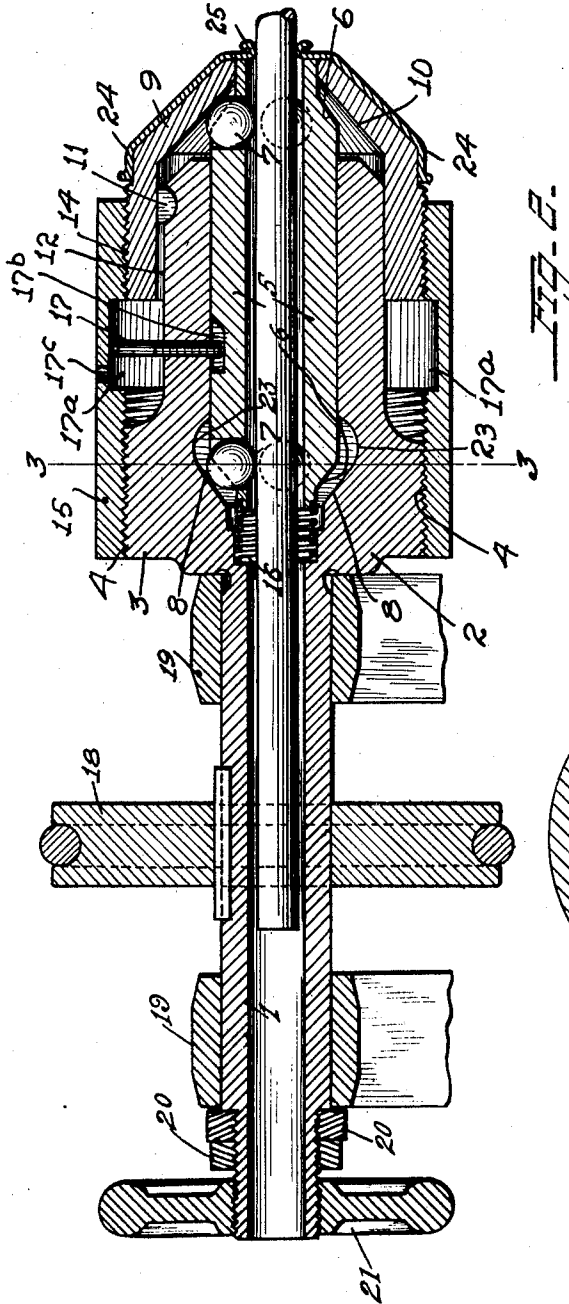

FIG. 2.

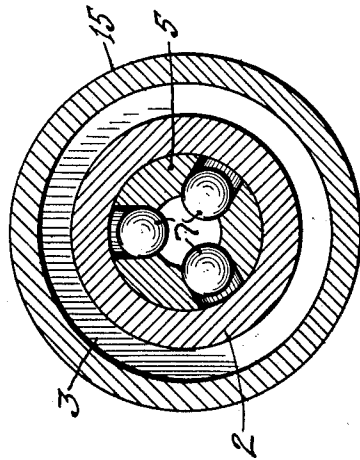

FIG. 3.

Inventor
H. A. Hanson

384 *Wm. Talbot*
Attorney

UNITED STATES PATENT OFFICE.

HANS A. HANSON, OF CEDAR RAPIDS, IOWA.

VALVE-GRINDING CHUCK.

Application filed April 21, 1925. Serial No. 24,815.

To all whom it may concern:

Be it known that HANS A. HANSON, a citizen of the United States of America, residing at Cedar Rapids, in the county of Linn and State of Iowa, has invented new and useful Improvements in Valve-Grinding Chucks, of which the following is a specification.

The purpose of the invention is to provide a device for use in connection with a rotary head and adapted to engage a valve stem for the purpose of rotating the valve in the grinding and truing operation of the latter; to provide a chuck construction in which the work gripping members are loosely mounted and so actuated in the clamping operation as to insure the holding of the stem or other work with which the device is used axially true with the rotary head; to provide a construction which is simple in form and therefore may be easily and cheaply produced; and to provide a flexible shield for the device to protect its working parts from the dust of the grinding wheel when the device is used for grinding purposes.

With this purpose in view, the invention consists in a construction and combination of parts, of which a preferred embodiment is illustrated in the accompanying drawings, wherein:

Figure 1 is a view in side elevation of the device, partly broken away.

Figure 2 is a central longitudinal sectional view on the plane indicated by the line 2—2 of Figure 1.

Figure 3 is a transverse sectional view on the plane indicated by the line 3—3 of Figure 2.

Figure 4 is a transverse sectional view on the plane indicated by the line 4—4 of Figure 1.

Formed as an integral part of the spindle 1, which is hollow to provide for the reception of a valve stem or long rod being rotated by the device, the head 2 is formed at the rear or heel portion with a flange 3 peripherally threaded, as at 4, the threads on this flange being preferably right handed. The head 2 is of tubular form for the reception of a jaw-holding arbor 5 which, at its remote ends, is beveled, as at 6, the beveled portions being slotted to provide pockets for the reception of balls 7 which constitute the jaws.

The pockets communicate with the interior bore of the arbor through openings which are of slightly less diameter than the diameters of the balls to preclude the latter dropping into the bore when there is no work mounted in the chuck. The head interiorly and at the inner or heel end is provided with beveled camming surfaces 8 with which the balls contact and as the arbor is moved rearwardly of the head, the balls are forced radially inward by these camming surfaces into contact with the peripheral surface of the valve stem or rod carried by the device.

Telescoping the head at the end remote from the flange 3 is a thimble 9 likewise provided with inclined interiorly disposed camming surfaces 10. These camming surfaces 10 engage the balls at the forward end of the arbor and when the thimble is moved inwardly, as it is in the operation of the device, the forward balls are forced into engagement with the work. The thimble is mounted for movement axially of the head but is precluded from relative angular movement thereon by means of a key 11, preferably of the Woodruff form, being seated in the head and engaging a key-way 12 formed on the interior surface of the thimble.

The thimble is exteriorly threaded, as at 14, but these threads are the reverse of the threads 4 and are, therefore, left handed. The reversely formed threads 4 and 14 are engaged with correspondingly formed interior threads in a sleeve 15 which surrounds the head and likewise surrounds the thimble and it is obvious that if the sleeve be rotated relative to the head, the sleeve will be moved axially of the latter and the thimble likewise so moved. The camming surfaces 10 and 8 will then function and the balls at the forward and rear ends of the arbor 5 will be forced radially inward into clamping engagement with the work which extends through the arbor 5 and into or through the bore of the spindle 1.

The arbor is yieldingly impelled toward the thimble by means of a spiral compression spring 16 of a diameter in excess of the bore of the arbor and spindle and thus tends to keep the balls at the forward end of the arbor projecting radially into the bore of the latter to their fullest extent but this does not preclude the mounting of the work since the forcing of the valve stem or rod into the

arbor will tend to force the arbor backwardly and thus free the balls so they will tend to move outwardly of the bore and permit the ready entrance of the work. At the same time the tendency of the spring is to keep the balls at the rear end of the arbor away from their camming surfaces so that they may be readily forced out of the way by the entering work.

The arbor 5 is precluded from angular or turning movement with respect to the head and the means for accomplishing this consists of a screw 17 threaded radially through the head, the inner end of the screw entering a slot 17^b in the arbor and the outer end being disposed in a peripheral recess 17^a on the interior of the sleeve 15. A hole 17^c in the sleeve 15 provides for access to the screw 17 in one position of the sleeve, to adjust the screw or to remove and replace it.

The head and whole mechanism is rotated by means of a pulley 18 mounted on the spindle 1 between the bearings 19 and end play of the spindle is taken up by adjusting nuts 20 threadingly engaged with the spindle and behind which the spindle carries a hand wheel 21 having an internally threaded eye engaging the threads at the rear end of the spindle and secured, when mounted, against turning movement relative to the spindle by means of a clamping screw 22 spanning a split formed in the hand wheel.

Interiorly, the head is provided with a peripheral clearance recess 23 to accommodate the jaw balls when the latter are moved radially outward to their fullest extent. The hand wheel functions as a means for holding the spindle and therefore the head against rotation when tightening or loosening the chuck as by rotating the sleeve 15 and thus makes unnecessary the holding of the spindle against rotation by grabbing the belt or introducing some obstruction to the rotation of the drive pulley.

When used in connection with grinding operations, it is essential that the interior parts be protected from the dust of the grinding element. Therefore, a shield 24 is provided and is made preferably of rubber and is closed at its end except where an eye

25 is provided to permit the work entering the arbor 5. The cylindrical portion of the shield is stretched over the thimble 9 and frictionally engages the latter and it is therefore unnecessary that it be removed in mounting or dismounting the work from the chuck.

The invention having been described, what is claimed as new and useful is:

1. A device for the purpose indicated comprising a head, an arbor axially movable in said head, spherical jaw members carried by said arbor, a thimble telescoping the head, the thimble and head having cam surfaces engaging said spherical jaw members, means for imparting relative axial movement to said thimble and head to effect radial inward movement of said spherical jaw members.

2. A device for the purpose indicated comprising a head, an arbor axially movable in said head, spherical jaw members carried by said arbor, a thimble telescoping the head, the thimble and head having cam surfaces engaging said spherical jaw members, means for imparting relative axial movement to said thimble and head to effect radial inward movement of said spherical jaw members, and consisting of a sleeve surrounding said head and thimble and threadingly engaged with the same, the one the reverse of the other, and a pin carried by the head and engaging a slot in the arbor.

3. A device for the purpose indicated comprising a head having an attached spindle, an arbor mounted in the head and axially movable of the latter and provided with spherical jaw elements at opposite ends, a thimble carried by the head, the thimble and head having camming surfaces engaging the said spherical jaw elements, an operating sleeve surrounding the head and the thimble and having reversely threaded connections with the two, and a hand wheel carried by the spindle at the remote end of the head to hold the head stationary during the operation of the sleeve.

In testimony whereof he affixes his signature.

HANS A. HANSON.