

REPUBLIC OF SOUTH AFRICA
PATENTS ACT, 1978

PUBLICATION PARTICULARS AND ABSTRACT

(Section 32(3)(a) – Regulation 22(1)(g) and 31)

OFFICIAL APPLICATION NO.

LODGING DATE

ACCEPTANCE DATE

21	01	2004/2016
----	----	-----------

22	19 SEP 2002
----	------------------------

43	14.3.05 S. P. 2004
----	-----------------------

INTERNATIONAL CLASSIFICATION

NOT FOR PUBLICATION

51	F03D
----	------

CLASSIFIED BY: WIPO

FULL NAMES OF APPLICANT

71	NIKOLAUS, THOMAS
----	------------------

FULL NAMES OF INVENTOR

72	NIKOLAUS, THOMAS
----	------------------

EARLIEST PRIORITY CLAIMED

COUNTRY

NUMBER

DATE

33	DE
----	----

31	101 47 013.4
----	--------------

32	25 SEP 2001
----	-------------

TITLE OF INVENTION

54	WIND POWER MACHINE
----	--------------------

57	ABSTRACT (NOT MORE THAT 150 WORDS)
----	------------------------------------

NUMBER OF SHEETS	41
------------------	----

If no classification is finished, Form P.9 should accompany this form.
The figure of the drawing to which the abstract refers is attached.

ABSTRACT

The invention relates to a wind power machine which is used to produce energy, comprising at least one rotor element (5) which can be driven by wind and a consumer (15), especially a generator (16); which is directly or indirectly connected thereto. According to the invention, one or a plurality of hydraulic pumps (7) are directly or indirectly driven by the rotor element (5).

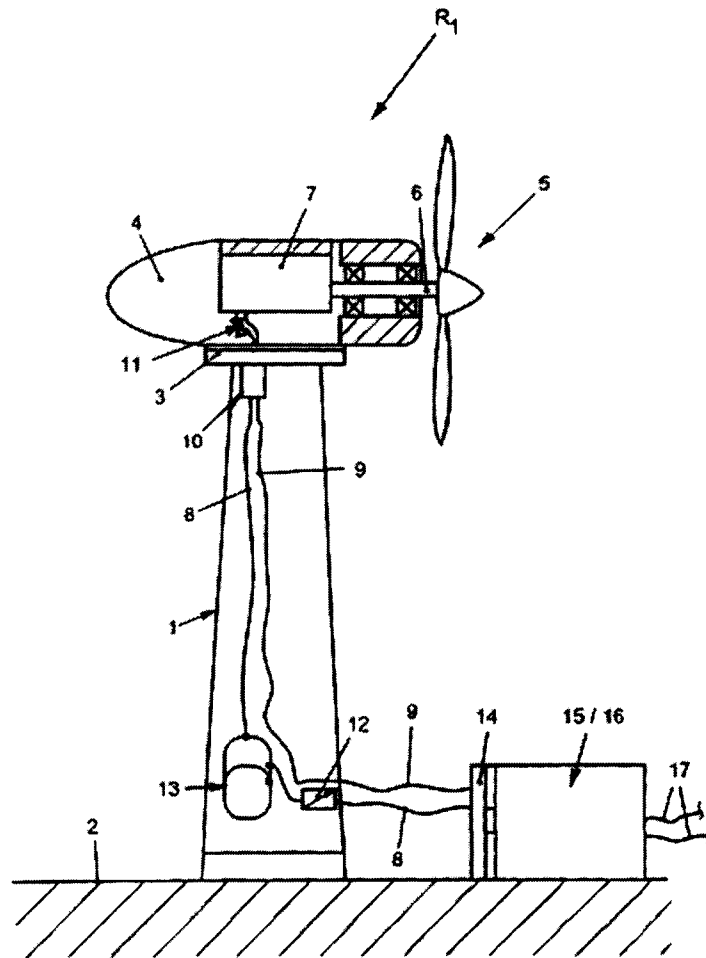

Wind power machine

The present invention relates to a wind power machine for production of energy, having at least one rotor element which can be driven by the wind, and an output load, in particular a generator, which is connected directly or indirectly to it.

Wind power machines such as these are commercially available in many different forms and embodiments and are used for the production of energy, in particular for electricity generation. Conventional wind power machines are generally formed from a pylon, to which a pylon attachment is fitted such that it can rotate. A generator, possibly a transmission and a rotor element connected to it are mounted in this pylon attachment.

The rotor element is driven by the wind and transmits a rotary movement, possibly via an intermediate transmission, directly to a generator.

This has the disadvantage that the weight of the generator, in particular of a very high-power generator, is at a very high level, and very severe oscillations often occur when the wind loads are high with very large wind power machines with tall pylons, so that the wind power machine must be switched off.

A further disadvantage is that the heavy weight of the generator, in particular, makes installation more difficult since costly cranes are required in order to fit the pylon attachment to the pylon.

A further disadvantage is that the maintenance work on the generator and, if appropriate, on the intermediate transmission element is carried out in the pylon attachment, and the maintenance personnel have to enter the pylon attachment, which is time-consuming. Spare parts must likewise also be transported up into the pylon attachment.

A further disadvantage with conventional wind power machines or wind parks is that, when the wind speeds are very high, they must be switched off owing to the very high rotation speeds of the rotor element, in order to prevent the wind power machines from oscillating in a correspondingly dangerous manner.

Furthermore, as is evident from the Weibull distribution, only quite specific wind spectra or ranges can be used and converted to a power output optimally, and this is disadvantageous. A further disadvantage is that only a quite specific proportion of the energy is utilized, by means of conventional technology. Furthermore, wind power machines such as these must be positively controlled in particular with respect to rotation of the pylon attachment, which likewise involves costs and control complexity.

The present invention is based on the object of providing a wind power machine of the type mentioned initially which overcomes the stated disadvantages, and by means of which the amount of energy which is taken from the wind by the wind power machine is increased significantly in

a cost-effective and effective manner, so that the overall efficiency of a wind power machine is improved. A further aim is to minimize the maintenance costs, production costs and installation costs, and to increase the power output and life of the wind power machine.

This object is achieved by the features of patent Claim 1 and by the features of the other independent patent Claims 2 and 3.

In the present invention, a rotor element is connected to a hydraulic pump either directly or by means of an intermediate transmission in each case. The rotary movement of the rotor element is converted in the hydraulic pump to hydraulic pressure, which is passed to an output load via lines which are preferably routed in the interior of the pylon of the wind power machine to its base area. The hydraulic pressure is preferably supplied to a converter, which converts pressure energy from the hydraulic pressure that has been built up to a rotary movement in order to drive any desired output load, preferably a generator. The hydraulic fluid is supplied back to the hydraulic pump in the pylon attachment via an appropriate return line.

Hydraulic pumps such as these are considerably smaller and more cost-effective, and are easier to produce and to operate than conventional wind power machines with generators in the pylon attachment. The hydraulic pumps can thus be inserted into a pylon attachment of a wind power

pump to hydraulic pressure, which is passed to an output load via lines which are preferably routed in the interior of the pylon of the wind power machine to its base area. The hydraulic pressure is preferably supplied to a converter, which converts pressure energy from the hydraulic pressure that has been built up to a rotary movement in order to drive any desired output load, preferably a generator. The hydraulic fluid is supplied back to the hydraulic pump in the pylon attachment via an appropriate return line.

Hydraulic pumps such as these are considerably smaller and more cost-effective, and are easier to produce and to operate than conventional wind power machines with generators in the pylon attachment. The hydraulic pumps can thus be inserted into a pylon attachment of a wind power

machine quite easily, and with virtually no maintenance, and can be connected to a rotor shaft of the rotor element.

One advantage of the present invention in this case is that the output load, which may be any desired output load, but is preferably a generator, can be arranged close to the ground or in the base area of the pylon, or in the ground area away from the pylon.

The output load can then easily be maintained and replaced, if necessary, in the event of wear.

A further significant advantage is that two or more wind power machines, possibly also of different types or in a wind park, can be connected to the single converter and to the single output load, in particular a generator, so that only one generator need be provided in order to convert the pressure energy that is produced from the hydraulic pumps to electrical energy.

This allows wind parks to be designed, operated and maintained at a considerably lower cost.

Furthermore, it has been found to be advantageous to insert a restriction element into the line for control purposes, in particular in order to limit the rotation speed of the rotor element for critical rotation speeds, which restriction element can be controlled such that a critical rotor element speed can be regulated via the flow rate through the restriction. This allows the rotor element to be

braked very easily, without wear and at low cost. There is therefore no need for costly, heavy, conventional brakes.

The insertion of controllable valves into the line as well as the return line, or possibly in the hydraulic pump itself, also allows the rotor element to be fixed such that it cannot rotate, and the wind power machine can be switched on in a simple and cost-effective manner, without any wear. This is likewise intended to be within the scope of the present invention.

The scope of the present invention is also intended to cover the fact that a pump, for example, may be connected as the output load. This pump can be used, for example, to pump water to a reservoir which is at a higher energy level in order, for example, to drive a turbine, which is at a lower level and is connected to a generator for electricity generation by means of this water that is at a higher level, for example at peak load times. By way of example, this allows energy to be provided very quickly at peak load times, if, for example, the wind power machines are emitting relatively low power outputs. Thus, overall, a wind power machine, in particular a wind park, can be designed which also makes it possible for the wind power machine or wind park to provide an influence in the event of different power levels, winds, lack of wind or at peak load times.

With the present invention, it has also been found to be particularly advantageous that two or more hydraulic pumps

can be associated with a single wind power machine, in which case, if required, the hydraulic pumps may be subdivided into different power groups. The individual hydraulic pumps can be driven or regulated on the basis of the rotation speed or as a function of the power output of the rotor element, so that the rotor element can be driven even by very high wind speeds or extremely low wind speeds and a rated rotation speed can be regulated, in particular controlled, on the basis of the pumps which can be connected. This allows the energy yield to be optimized with regard to the Weibull distribution, so that an optimum yield and conversion of the wind energy are possible over wide ranges.

Furthermore, it has been found to be advantageous for it to be possible to supply two or more output loads or generators from one or at least two or more wind power machines, so that the output loads or generators can be operated, if required, with upstream converters on a correspondingly power-output specific or pressure-specific basis. In this case, for example, generators can be provided in different power output levels and in different quantities, for example 100 kW, 250 kW, 350 kW, etc, in a wind park, and can be connected directly to a number of wind power machines, so that small generators with a relatively low power output can be operated optimally and with optimized efficiency for low power output ranges when there is little wind. This is

likewise intended to be within the scope of the present invention.

Furthermore, it has been found to be advantageous that the very light pylon attachment 4 means that there is no need to align it in a positively controlled manner by means of electric motors or the like with respect to the wind, but that it can be operated mechanically, possibly by means of rudder control. This is likewise a considerable advantage of the present invention.

Further advantages, features and details of the invention will become evident from the following description of preferred exemplary embodiments and from the drawing, in which:

Figure 1 shows a schematically illustrated side view of a wind power machine according to the invention;

Figure 2 shows a schematically illustrated side view of a number of wind power machines;

Figure 3 shows a schematically illustrated plan view of a number of wind power machines;

Figure 4 shows a schematically illustrated side view of a further exemplary embodiment of a wind power machine as shown in Figure 1;

Figure 5 shows a schematically illustrated side view of a wind power machine as shown in Figure 4, connected to a number of generators or output loads;

Figure 6 shows a schematically illustrated plan view of a further exemplary embodiment of a number of wind power machines as a further exemplary embodiment as shown in Figure 3.

As is shown in Figure 1, a wind power machine R_1 according to the invention has a pylon 1 which is installed on a base 2. The pylon 1 is seated on a pylon attachment 4 via a bearing element 3 such that it can rotate, and the pylon attachment 4 is fitted with at least one rotor element 5.

The rotor element 5 is driven by the wind such that it rotates about a rotor shaft 6.

According to the invention, the rotor shaft 6, and hence the rotor element 5, are connected to a hydraulic pump 7. The rotational movement of the rotor element 5 and of the rotor shaft 6 allows the hydraulic pump 7 to be driven and to produce a hydraulic pressure, which is passed on via a first line 8. A return line 9 is furthermore likewise connected to the hydraulic pump 7.

The line 8 and the return line 9 between the hydraulic pump 7 preferably open into a coupling 10, which compensates for and equalizes any rotational movement of the pylon attachment 4 with respect to the rigid pylon 1.

A restriction element 11, in particular a controllable restriction, is preferably inserted into the line 8 between the coupling 10 and the hydraulic pump 7,

although a controllable valve 12 may also be inserted into the line 8, additionally or alternatively, or, as is illustrated in Figure 1, close to the base 2.

It is also intended to be within the scope of the invention for a pressure equalization device 13, in particular a pressure equalization container, to be inserted in the line 8. The line 8 or the return line 9 are preferably connected to an externally mounted converter 14, which is connected to the output load 15 or generator 16, as illustrated in particular in Figure 1, with the converter 14 converting the pressure energy that is produced by the hydraulic pump 7 to a rotary movement in order to drive the output load 15, preferably the generator 16, in order to generate electricity. The generator 16 can pass on the energy that is produced via a network feeder 17. In this case, the present invention is also intended to include the aim of arranging the output load 15, in particular the generator 16, within the pylon 1, or to accommodate it there.

A further important feature of the present invention is that the output load 15 or generator 16 can be installed nearby in the area of the base 2 of the pylon 1, or externally away from the pylon 1. This considerably reduces the weight, in particular of the pylon attachment 4, since a hydraulic pump 7 is considerably lighter than a conventional generator.

A further advantage of the present invention is that the restriction 11 allows the flow rate in the line 8 to be controlled exactly. This makes it possible, for example, to regulate out or limit a critical speed of the rotor element 5. The restriction 11, which is connected to a controller that is not illustrated here, can thus brake the rotor element 5, in particular by limiting the flow through the hydraulic pump 7.

Switching off, for example for maintenance purposes, is also feasible easily, for example by closing the valve 12, which is not illustrated here, via a controller, with the rotor element 5, and hence the hydraulic pump 7 stopped in this way.

In this case, it is also intended to be within the scope of the present invention for the valve 12 to be inserted into the line 8 and/or return line 9, for example between the coupling 10 and the hydraulic pump 7. The invention is not restricted to this.

In order to compensate for pulsations in the line 8 and/or return line 9 and gusty wind loads on the rotor element 5, it has been found to be advantageous to preferably insert a pressure equalization container 13 into the line 8.

In the exemplary embodiment of the present invention shown in Figure 2, a number of wind power machines R_1 , R_2 are positioned on a base 2 in a wind park, in which case it is also intended to be within the scope of the present invention

for wind power machines R_1 , R_2 of different types to be operated in the manner described above. In this case, the wind power machine R_2 may have rotor elements 5 which revolve radially around the pylon 1 and drive the hydraulic pump 7 in the manner described above.

The corresponding lines 8 and return lines 9 may be used, for example, to connect two or more wind power machines R_1 , R_2 to at least one converter 14 for an output load 15, preferably a generator 16, so that the overall costs for a wind park can also be considerably reduced by using a small number of generators 16, or only a single generator 16, when using two or more wind power machines R_1 , R_2 .

The exemplary embodiment of the present invention as shown in Figure 3 illustrates how two or more wind power machines R_1 , R_2 can be connected in parallel via the lines 8, 9 to a common supply line 18 and common return lines 19, which are connected to the converter 14.

This also makes it possible, for example, to provide pressure equalization between individual wind power machines R_1 , R_2 , so that the converter 14 is provided with a continuous pressure and a continuous drive power level for driving the output load 15 or generator 16.

In this case, it is feasible to insert non-return valves into the individual lines 8.

It is also possible for two or more converters 14 with generators 16 connected to them to be connected to two

or more wind power machines, in order to produce a very high output power level.

It is also intended to be feasible to connect two or more output loads 15 or generators 16 to the converter 14. The invention is not restricted to this.

In a further preferred exemplary embodiment of the present invention as shown in Figure 4, a wind power machine R_3 is illustrated which, as shown in Figure 1, corresponds approximately to the wind power machine R_1 .

The difference is that the wind power machine R_3 has two or more associated hydraulic pumps 7 in the pylon attachment 4.

In this case, the individual hydraulic pumps are connected to the rotor shaft 6 of the rotor element 5, preferably via a common transmission element 22.

Toothed belts, epicyclic gears, gear wheels or the like may be used as the transmission element 22 in order to connect or couple the individual hydraulic pumps 7 to the rotary movement of the rotor shaft 6 of the rotor element 5 directly or with a step-up ratio which can be selected.

However, one important factor with regard to the present invention is that the individual hydraulic pumps 7 can be connected selectively, depending on the rotation speed of the rotor element 5 via a regulation device 20, which is likewise preferably provided in the pylon attachment 4.

A further important feature of the present invention is that the individual hydraulic pumps 7 are provided, for example, in different power levels in the wind power machine R_3 or in the pylon attachment 4.

This means that the rotor element 5 can always be operated at a rated rotation speed which can be selected, so that this also makes it possible to make optimum use of regions with high wind strengths. This makes it possible to avoid high rotation speeds of the rotor element 5, and the rotation speed of the rotor element 5 can be controlled or restricted optimally in all wind strength ranges, so that the power output yield is optimized in all wind strength ranges. From one to all of the hydraulic pumps may also be connected in a combined form for this purpose.

In the exemplary embodiment of the present invention shown in Figure 5, a similar exemplary embodiment is used to show that two or more output loads 15 or generators 16 can be connected to at least one wind power machine R_3 , with the individual output loads 15 or generators 16 being connected via control devices 21, which are indicated here, with a common line 8 or return line 9 of the wind power machine R_3 via a common supply line 18 and a common return line 19.

In this case as well, it is advantageous that different output loads 15 or generators 16, for example with different output power levels, can be connected selectively, in particular with the capability to be controlled via a

common monitoring unit 23, on a power-output specific basis depending on the power output of the at least one wind power machine R_3 , which power output is fed in the form of a pressurized medium into the supply line 18 and return line 19.

This ensures that, when the wind strengths are extremely low, only one output load 15 or generator 16 whose power output is low is fed, so that, even in this case, the power output, in particular the generator, is used in an optimized manner.

In this case, it is also intended to be within the scope of the present invention, as is illustrated in Figure 6, for two or more output loads 15 or generators 16 to each be connected separately via control devices 21 to two or more hydraulic pumps 7 and wind power machines R_1 to R_3 , in which case each individual wind power machine R_1 to R_3 can be controlled on a wind-specific basis via two or more hydraulic pumps in order to produce an optimized power output, in which case power-output specific output loads 15 and/or generators 16 can be connected individually, together, in particular controllable and selectively via control devices 21.

DR. PETER WEISS & DIPL.-ING. BRECHT

Patent Attorneys

European Patent Attorney

File reference: P 2710/PCT

Date: September 19, 2002 B/HU

List of item numbers

1	Pylon	34		67	
2	Base	35		68	
3	Bearing element	36		69	
4	Pylon attachment	37		70	
5	Rotor element	38		71	
6	Rotor shaft	39		72	
7	Hydraulic pump	40		73	
8	Line	41		74	
9	Return line	42		75	
10	Coupling	43		76	
11	Restriction element	44		77	
12	Valve	45		78	
13	Pressure equalization container	46		79	
14	Converter	47			
15	Output load	48		R ₁	Wind power machine

16	Generator	49		R ₂	Wind power machine
17	Network feeder	50		R ₃	Wind power machine
18	Supply line	51			
19	Return line	52			
20	Regulation device	53			
21	Control device	54			
22	Transmission element	55			
23	Monitoring unit	56			
24		57			
25		58			
26		59			
27		60			
28		61			
29		62			
30		63			
31		64			
32		65			
33		66			

Patent Claims

1. A wind power machine for production of energy, having at least one rotor element (5) which can be driven by the wind and having an output load (15), in particular a generator (16), which is connected directly or indirectly to the rotor element (5),
characterized
in that the rotor element (5) drives one or more hydraulic pumps (7) directly or indirectly.
2. A wind power machine for production of energy, having at least one rotor element (5) which can be driven by the wind and having an output load (15), in particular a generator (16), which is connected directly or indirectly to the rotor element (5), characterized in that two or more hydraulic pumps (7) can be connected via at least one regulation device (20) as a function of the power output level of the rotor element (5), in particular as a function of the torque or rotation speed of the rotor element (5).
3. A wind power machine for production of energy, having at least one rotor element (5), which can be driven by the wind and having an output load (15), in particular a generator (16), which is connected directly or indirectly to the rotor element (5), characterized in that one or more wind power machines or two or more hydraulic pumps (7) feed two or more generators (16) and/or output loads (15) in a manner

which can be controlled as a function of the power output level.

4. The wind power machine as claimed in Claim 3, characterized in that the at least one generator (16) and/or output load (15) is subdivided into different power levels, and can be distributed to the at least one generator (16) and/or output load (15) on a power-output specific basis via at least one control device (21) depending on the power which is emitted by the at least one wind power machine (R_1 to R_3).

5. The wind power machine as claimed in at least one of Claims 1 to 4, characterized in that two or more wind power machines have two or more hydraulic pumps (7) which can be connected and supply, on a power-specific basis, two or more generators (16) and/or output loads (15) which can be connected and can be controlled.

6. The wind power machine as claimed in at least one of Claims 2 to 5, characterized in that the two or more hydraulic pumps (7) can be connected selectively via controllable control devices (20) for power optimization, with the hydraulic pumps (7) being arranged in different power levels in the pylon attachment (4).

7. The wind power machine as claimed in at least one of Claims 1 to 6, characterized in that a transmission element (22) is connected between the rotor element (5) and the hydraulic pumps (7) in order to drive the two or more hydraulic pumps (7) in the pylon attachment (4).

8. The wind power machine as claimed in at least one of Claims 2 to 7, characterized in that two or more generators (16) and/or output loads (15) can be driven via a monitoring unit (23) in different power output level levels of at least one wind power machine (R_1 to R_3), in particular of at least one hydraulic pump (7), in each case individually controllable and at least partially as a function of the power output level and/or pressure.

9. The wind power machine as claimed in at least one of Claims 1 to 8, characterized in that the at least one hydraulic pump (7) is connected to an output load (15), in particular to a generator (16), and drives it.

10. The wind power machine as claimed in at least one of Claims 1 to 9, characterized in that the output load (15), in particular the generator (16), can be driven externally by the wind power machine, in particular by the rotor element (5) via the hydraulic pump (7).

11. The wind power machine as claimed in at least one of Claims 1 to 10, characterized in that two or more individual wind power machines (R_1 , R_2) can be connected by means of rotor elements (5) and connected hydraulic pumps (7) to a common output load (15), in particular to a common generator (16), and drive it.

12. The wind power machine as claimed in at least one of Claims 1 to 11, characterized in that the hydraulic pump (7) is connected directly to the rotor element (5) and is

connected via lines (8, 9) to a converter (14) for a generator (16), with the converter (14) driving the generator (16).

13. The wind power machine as claimed in at least one of Claims 1 to 12, characterized in that a controllable restriction element (11) and/or a controllable valve (12) is inserted in at least one line (8, 9) for open-loop and/or closed-loop control and/or for braking.

14. The wind power machine as claimed in at least one of Claims 1 to 13, characterized in that at least one pressure equalization device (13), in particular a pressure equalization container for pressure and/or pulsation equalization, is inserted between the hydraulic pump (7) and the output load (15), in particular the generator (16).

15. The wind power machine as claimed in at least one of Claims 1 to 14, characterized in that the rotor element (5) drives the hydraulic pump (7) via a rotor shaft (6).

16. The wind power machine as claimed in at least one of Claims 1 to 15, characterized in that this wind power machine has a pylon (1) and, at its end, a pylon attachment (4) which can rotate, with the rotor element (5) being mounted in the pylon attachment (4) such that it can rotate, and being connected to the hydraulic pump (7) there.

17. The wind power machine as claimed in Claim 16, characterized in that the lines (8, 9) are passed via a coupling (10), such that they are decoupled in terms of

rotation, through the pylon (1) to an output load (15), in particular a generator (16), which is arranged in the pylon (1), on the pylon (1) or externally from the pylon (1).

18. The wind power machine as claimed in Claim 16 or 17, characterized in that two or more hydraulic pumps (7) for different wind power machines (R_1 , R_2) can be connected to at least one generator (16).

19. The wind power machine as claimed in at least one of Claims 1 to 18, characterized in that two or more wind power machines (R_1 , R_2) can each be connected via a line (8) and a return line (9) to a common supply line (18) and to a common return line (19), to which at least one converter (14) is connected, and to which converter (14) at least one output load (15) and/or generator (16) is connected.

20. The wind power machine as claimed in at least one of Claims 1 to 19, characterized in that the output load (15) is in the form of a pump for feeding the water to a reservoir at a higher level.

21. The wind power machine as claimed in Claim 20, characterized in that the reservoir which is at a higher level is connected to a turbine, which is at the lower level, for driving a generator (16).