

(No Model.)

3 Sheets—Sheet 1

J. KELLER.
PRINTING MACHINE.

No. 544,763.

Patented Aug. 20, 1895.

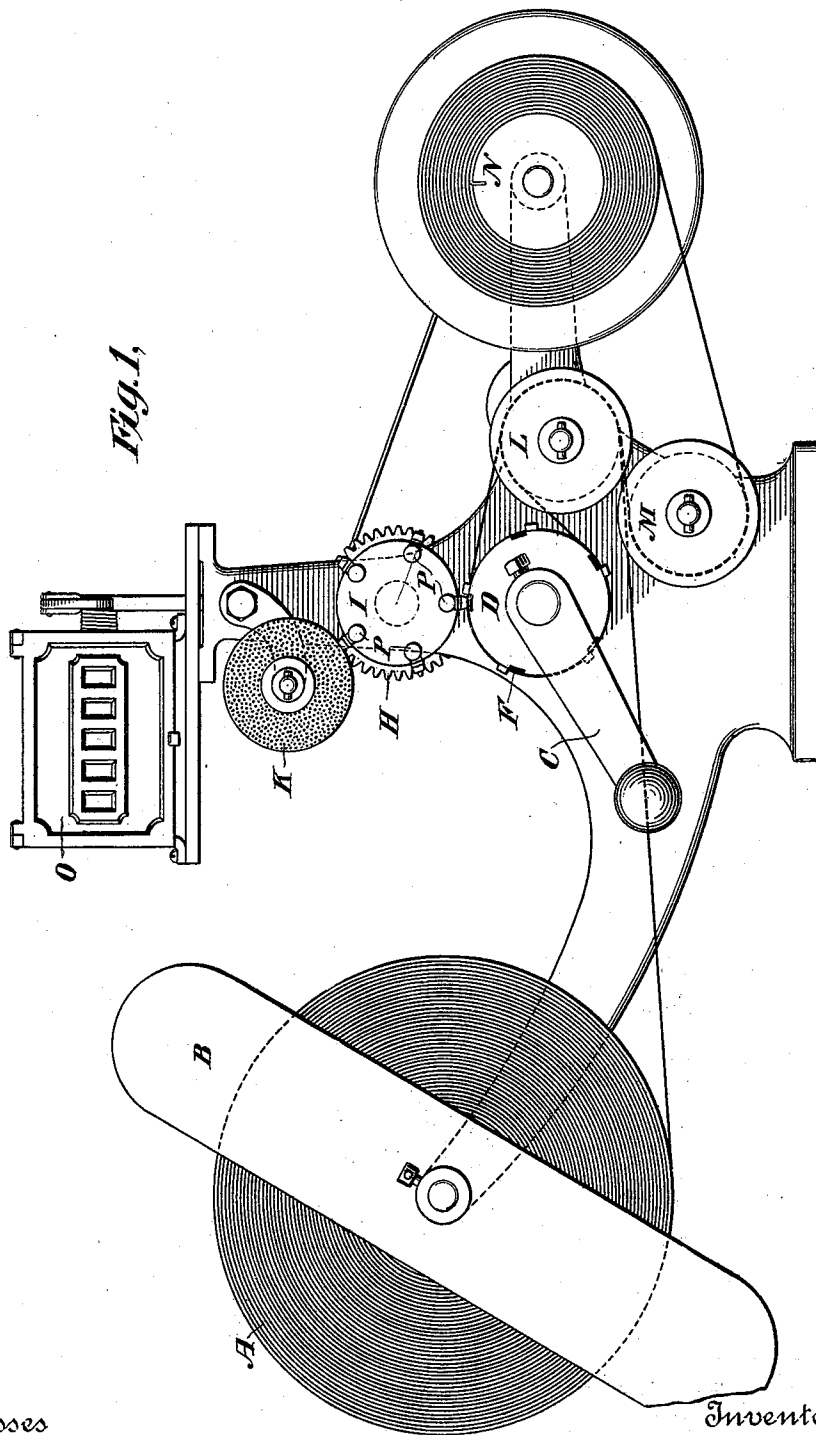

Witnesses

C. E. Ashley
H. W. Lloyd.

By his Attorneys

Inventor
John Keller
head & face

J. KELLER.
PRINTING MACHINE.

No. 544,763.

Patented Aug. 20, 1895.

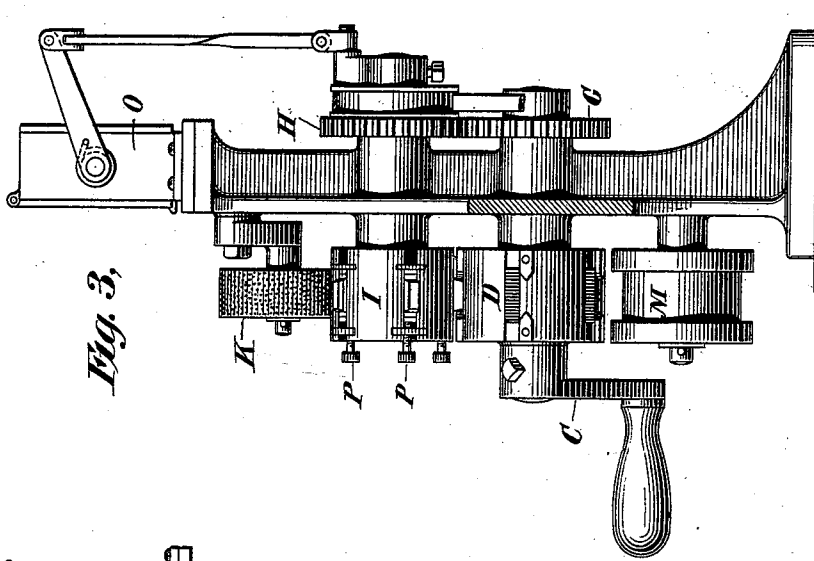

Fig. 3,

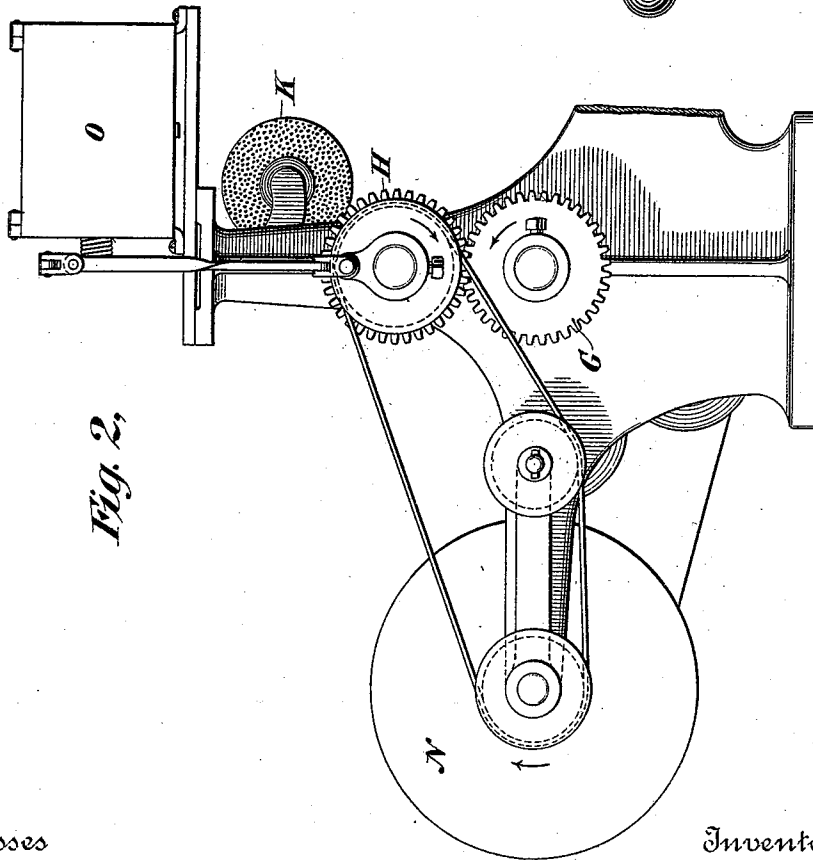

Fig. 2,

Witnesses

C. E. Ashley
H. W. Lloyd

Inventor

John Keller

By his Attorneys

Reed & Prich

(No Model.)

3 Sheets—Sheet 3.

J. KELLER.
PRINTING MACHINE.

No. 544,763.

Patented Aug. 20, 1895.

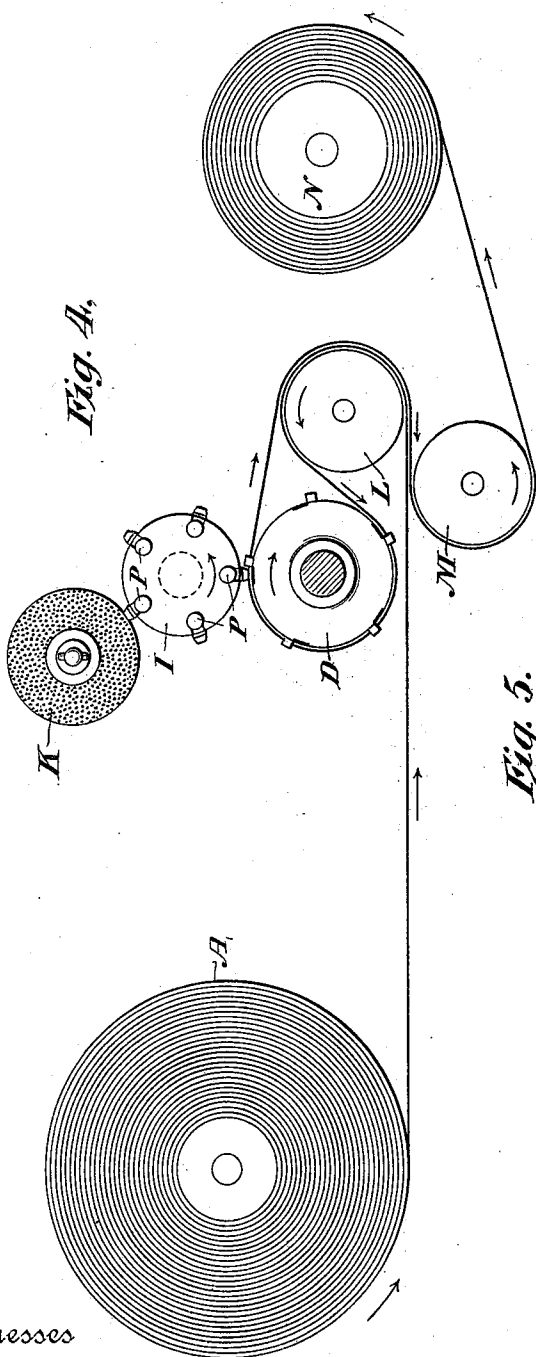
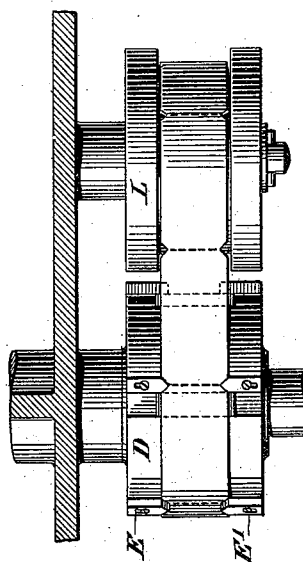

Fig. 4.

Fig. 5.



Witnesses
C. E. Ashley
W. W. Lloyd,

Inventor
John Keller
By his Attorneys
Read & Frei

UNITED STATES PATENT OFFICE.

JOHN KELLER, OF BROOKLYN, NEW YORK.

PRINTING-MACHINE.

SPECIFICATION forming part of Letters Patent No. 544,763, dated August 20, 1895.

Application filed December 21, 1892. Serial No. 455,930. (No model.)

To all whom it may concern:

Be it known that I, JOHN KELLER, a citizen of the United States, residing at Brooklyn, in the county of Kings and State of New York, have invented certain new and useful Improvements in Printing-Machines; and I do hereby declare the following to be a full, clear, and exact description of the invention, such as will enable others skilled in the art to which it appertains to make and use the same.

This invention relates to printing apparatus, and is especially intended for use in cases where it is designed to print a date or other matter upon a considerable number of tickets where such matter requires changing from time to time, and is therefore more conveniently conducted at the place where the tickets are to be used.

The object of the invention is to enable the printing to be accurately and rapidly done, so that the impression will properly register with the ticket or any desired portion thereof and a large number may be printed in a short time. With a view to this end I prepare a coil of cardboard ribbon of the width of the desired ticket and place it in the printing-machine I have designed, so that the operation of printing may be continuously carried on until the coil is exhausted. A difficulty experienced in practice in using a system of this kind arises from the fact that as the printing is conducted and the ribbon forming the tickets is unwound from one coil and wound upon another the varying diameters of the two coils produces an irregularity in the feed, or if the latter is mechanically arranged so as to prevent an irregularity in the feed the coils will be loosely and irregularly wound by reason of the slack upon the tape or coil and the part of the ribbon under the letter-press is not kept true by reason of such slack. In order to enable the several tickets to be conveniently separated from the main body of the coil or ribbon when the tickets are needed for use they are notched at the sides at intervals corresponding to the length of the ticket, so that they may be conveniently pulled apart or torn on a straight line. When a simple friction-feed is used upon such a ribbon, the strain being brought upon one point, it renders the ribbon liable to be torn, and the shifting by reason of the slack prevents the impression

being made at the same part of all the tickets. I avoid these difficulties by mechanism the several features of novelty of which will be hereinafter fully described, and definitely indicated in the claims appended to this specification.

In the accompanying drawings, which illustrate the invention, Figure 1 is a front elevation of an apparatus embodying my improvement. Fig. 2 is a rear elevation of the same with part broken away. Fig. 3 is a side elevation. Fig. 4 is a diagram of the feed and coiling arrangements, and Fig. 5 is a detached view of the feed-rolls.

I provide a coil of cardboard ribbon of a size sufficient to answer for a long term of service, the ribbon being notched at the sides, as indicated in Fig. 5, and this coil A is mounted upon an axis secured to or journaled in a bearing formed in an extension of the frame of the machine. A plate or disk B is provided at each side of the space to receive the coil, by which it is prevented from dishing, the outer plate being secured in place by a set-screw, so that it may be removed for insertion of a coil. The main shaft of the machine is provided with a crank or handle C, by which the feed and printing rolls are actuated. Upon this shaft is mounted a feed disk or roll D, provided at its sides with adjustable lugs E E', adapted to co-operate with the notches formed in the ribbon and pull upon the same when the crank-shaft is turned. A series of these lugs are provided at intervals corresponding to the length of the ticket and distributed at equal distances around the periphery of the disk D. The disk D also serves as the platen of the printing apparatus, having mounted in its periphery at intervals sections of soft or elastic material F, flush or approximately flush with the periphery. Mounted upon the same shaft as the disk D is a gear-wheel G, which co-operates with another gear-wheel H, mounted upon an adjoining shaft which carries on its front end a type-wheel I, provided at equal peripheral distances corresponding to the length of the ticket with a line or lines of type corresponding to the matter to be printed. The wheel is slotted in its periphery, the slots running parallel to the axis and the line or lines of type are placed in the slots, being adjusted

into tight engagement with the end walls of the slots by set-screws P P', &c. An inking-pad K is placed in co-operative relation to this type-wheel and continuously inks the type when the machine is in operation.

In order to prevent the ribbon from buckling or slipping and place the strain of feeding upon a number of the notched portions between consecutive tickets, I provide two idler-wheels L M, mounted upon suitable shafts secured to the frame, the former being of such a diameter or set in such relation to the disk D that the ribbon in passing through the machine will be forced to embrace a large portion of the circumference of the disk D, and thus bring a number of the lugs E E' into engagement with the notches in the ribbon. One convenient way of arranging the wheels L M is shown in the drawings, the former having its periphery close to the disk D and the latter being set below it. The ribbon is first passed around the wheel L and is then carried around the platen wheel or disk D, again passed over a portion of the periphery of L, and is then carried around the wheel M, after which it is carried to a winding-reel N. The reel N is operated by a belt driven by a pulley on one of the shafts carrying gear-wheel G or H. The ribbon is carried twice over the wheel L and arranged so that the side which delivers from the printing-wheels will slide upon the other side, the result of which is that irrespective of the feed of the ribbon to or from the reels it will always be taut on the disk D, the winding-reel being belted in such a way that it will take up sufficient slack in any condition of the coil. The coil A is arranged so as to move frictionally upon its axis. When the coil on reel N becomes of such a size that it would take up more slack ribbon than is fed by the apparatus its belt will slip, and by reason of the arrangement of the rolls

and the large amount of friction of the ribbon thereon the feed can be no greater than is required by the speed of the printing-wheels. It will thus be seen that the ribbon in passing over the disk D engages a considerable number of the lugs, and is held in true relation and cannot slip from the lugs, as would be the case if simply a single pair of the lugs established the feed. Moreover, any inequalities in delivery of the ribbon from the roll A cannot cause a buckling of the ribbon upon the feed-roll, as the latter is held down upon wheel L by the superincumbent discharge end passing around the wheel M to the coiling-reel. Upon the frame is mounted a suitable counter (indicated at O) actuated by a crank-shaft connected with one of the printing-wheels, which forms no part of the present invention and requires no further description.

Having thus described my invention, what I claim as new, and desire to secure by Letters Patent, is—

1. In a printing machine the combination of a crank-shaft, a feed disk operated thereby, said disk being provided with two peripheral rows of laterally adjustable lugs adapted to engage a notched ribbon at a plurality of points and rotary printing disk.

2. A ticket printing machine, comprising a driving shaft, printing wheels or rolls in gear therewith, guide rolls adjacent thereto, and frictionally operated supply and take-up reels so related to the printing and guide rolls that the material to be printed may be fed to and from the printing rolls over the periphery of the same guide roll, for the purpose set forth.

In testimony whereof I affix my signature in presence of two witnesses.

JOHN KELLER.

Witnesses:

ROBT. H. READ,
E. C. GRIGG.