

J. SOUTER.
Grain-Drier.

No. 167,797.

Patented Sept. 14, 1875.

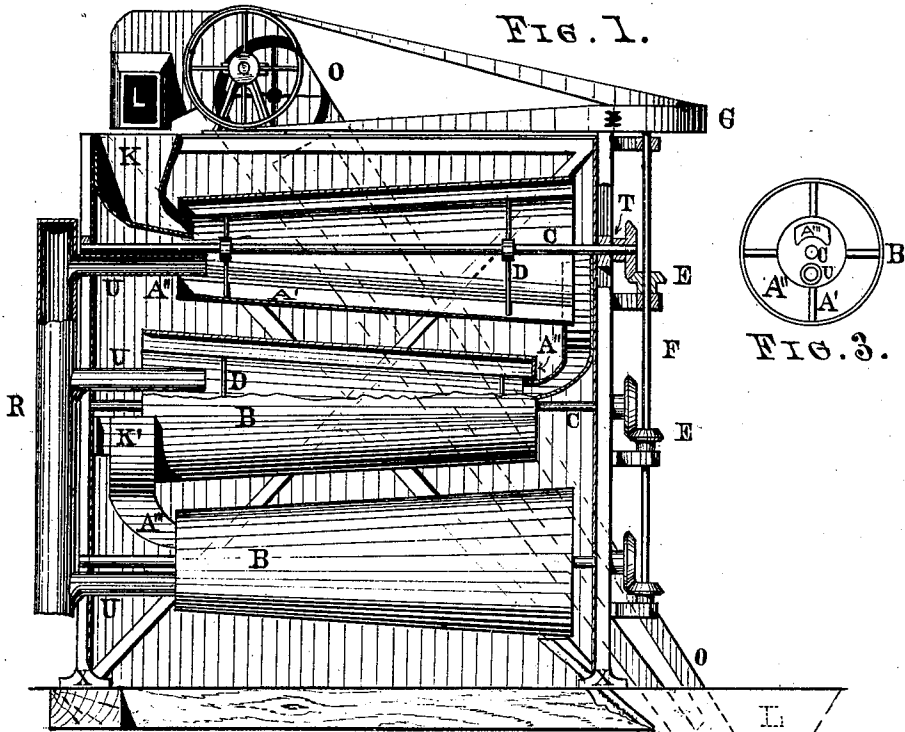
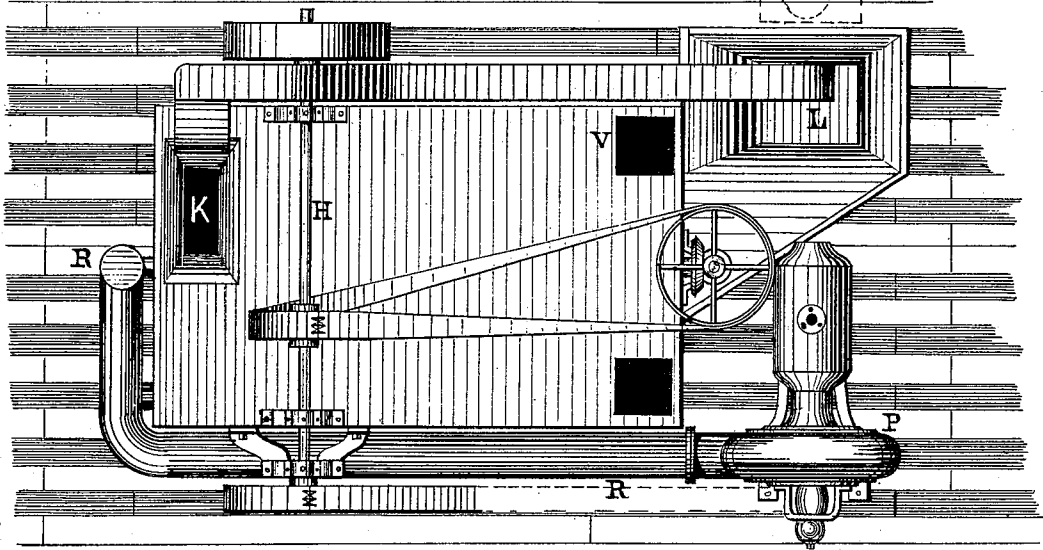

FIG. 2.



WITNESSES:

Frank Heirsch
John B. Edwards

INVENTOR:

Joseph Souter
by *Michael J. Stark*
his attorney.

UNITED STATES PATENT OFFICE.

JOSEPH SOUTER, OF BUFFALO, N. Y., ASSIGNOR OF TWO-THIRDS HIS RIGHT TO CHARLES LANKLER AND GEORGE A. PHILLIPS, OF SAME PLACE.

IMPROVEMENT IN GRAIN-DRIERS.

Specification forming part of Letters Patent No. 167,797, dated September 14, 1875; application filed August 2, 1875.

To all whom it may concern:

Be it known that I, JOSEPH SOUTER, of Buffalo, in the county of Erie and State of New York, have invented new and useful Improvements on Grain and Malt Driers; and I do hereby declare that the following description, taken in connection with the accompanying drawings, forms a full and exact specification, wherein are set forth the nature of my invention, and the mode in which it is best carried into effect.

The object of my present invention is the production of an apparatus whereupon wet grain, malt, and the like can be effectually dried, and the result obtained in a thorough and satisfactory manner. In order to perform these functions properly, I arrange within a suitably-constructed frame of metal or wood a number of revolving drums, having a conical or tapering shell, so that during the revolution thereof the grain shall feed itself automatically downward until it reaches the lower drum of the series, from whence it shall pass into a receiver to be elevated to the place of storage, or again over the drying apparatus, as circumstances shall demand. The said drums are arranged one above the other, in such a manner that the larger end of one shall be opposite the small end of the next drum below, and those ends connected by means of a conveyer or hopper surrounding the larger end, and entering the smaller end of the next lower drum. Within the said drums shall be arranged a series of longitudinal ribs projecting radially from the outer shell, which projections shall elevate the grain contained in the said drums while revolving, and drop it again, so as to spread it into small particles when subjected to a hot blast of air blown through the said drums, and thereby effectually dried and restored to a good and marketable condition.

To enable others skilled in the art to which my invention pertains to make and use the same, I shall proceed to describe its particulars, thereby referring to the hereinbefore-mentioned drawings, in which—

Figure 1 is a longitudinal sectional elevation of my improved drying apparatus. Fig. 2 is a plan of the same; and Fig. 3, an end view

of one of the revolving drums, similar parts being marked with corresponding letters in all the figures.

X is the frame for my drier. It is a rectangular skeleton of suitable material, properly connected and braced, and provided with a number of bearings arranged upon cross-ties T, to contain the shafts C of the revolving drums B. These drums B consist of conical shells of sheet metal, and they are connected with the shafts C by the spider-wheels D. Within the drums are arranged, radially projecting, a number of shelves or ribs, A', extending longitudinally the whole length of the said drums, while the smaller end of these drums are partially closed by a rim, A'', which rim serves to prevent the grain from escaping on that end of the drums B. The shafts C are arranged horizontally and parallel with each other, so as to revolve with but little friction. A series of the drums B are situated one above the other, with their larger end always opposite the smaller end of the next drum above, and they are revolved simultaneously by means of the bevel-gearing E, or other analogous contrivance, receiving its motion from the vertical shaft F through the pulley G, to which, in turn, motion is communicated from the main shaft H by means of a belt, as clearly shown in the drawings.

The grain to be dried enters the uppermost drum through the hopper K, and, passing through this drum, discharges into a conveyer, K', which conveyer surrounds the larger end of the drum B to within the center thereof, or higher, if necessary, to prevent the spattering of the grain on the discharge end of the drums, when the same is elevated by the radially-projecting ribs A', and dropping therefrom by gravitation, and influenced by the current of air passing out of the drum on that end, has a tendency to spatter. Thus the conveyer or hopper K' gathers the grain on the discharge end, and it delivers the same to the next drum below, &c., until it reaches the lowest drum, from whence it discharges into a receiver, L. An elevator, O, is stationed in this receiver L, to convey the grain either to the place of storage or again upon the drying apparatus if not properly dried. This elevator receives motion

from the main shaft H in the usual manner. The projections A' serve to elevate the grain within the drums B for a distance, and then to drop it again, thus separating the mass into the smallest number of particles, so that a blast of heated air, blown through the drums by means of a blowing-engine, P, ducts R, and branches U, will penetrate the grain, and effectually evaporate and absorb its moisture, so that when the said grain finally reaches the lowest drum it will be perfectly dry and in a condition suitable for market purposes.

The air is heated by means of a suitably-arranged furnace or a steam-heater before it enters the blower, and forwarded to the drums in such quantity and at such a temperature most suitable for the purpose; but if a hot-air furnace is connected with this apparatus the air should not be heated therein to such an extent as to scorch the grain.

In the drawing, Fig. 2, I have shown a blower provided with a steam-heater, consisting of a number of tubes arranged within a shell, the air passing through the tubes and superheated steam surrounding them, thus imparting to the air sufficient heat to accomplish the result to be obtained. This arrangement, however, is not an essential feature of my invention, and various other devices may be resorted to to heat the air.

The stationary branches U of the duct R enter the ends of the drums B, and extend therein for a distance to compel the air to take its course through the same, the branches being arranged as near the center of the said drums as is consistent with the other arrangements thereof.

The whole apparatus is provided with a jacket having outlets V to pass the products of evaporation, &c., and it serves the purpose of confining the heat within the drier.

It will be observed that the drums B consist of conical shells of non-perforated sheet metal, and that they revolve in a horizontal plane, their axial lines being horizontal and parallel with each other. By thus constructing the drums, the weight of the moving parts and the contents of the said drums are equally divided and distributed upon the bearings on each side of the shells, in direct opposition to

those grain-driers which have a cylindrical shell revolving in an inclined plane, and where the said weight and contents of the drums are thrown upon the lower bearing, thus causing undue strain and friction thereon, and otherwise impairing the proper action of the component parts.

Having thus fully described my invention, I desire to secure to me by Letters Patent of the United States the following:

1. In a drying apparatus, the combination, with a suitably-arranged frame, of the conical non-perforated drums arranged one above the other, and revolving with their axial lines in a horizontal plane, with the larger end of one drum opposite the smaller end of the next, substantially as described.

2. In a drying apparatus, the combination, with the non-perforated conical shell B, of the longitudinal radially-projecting ribs A', spiders D, and the shaft C, said shaft being arranged horizontally within a suitable frame, and rotated by mechanism, substantially as described, for the use and purpose set forth.

3. In a drying apparatus, the combination, with the drums B, arranged horizontally within a suitable frame, of the hopper K', hot-air duct R, and receiver L, said drums consisting of conical non-perforated shells, having spider-arms D and shafts C, and the inwardly-projecting rim A'', and revolving in a horizontal plane, substantially as described, for the purpose stated.

4. The combination, with the skeleton frame X, provided with the bearings for the shafts C, of the series of revolving drums B, having bevel-wheels E on their ends, connected with the upright shaft F, hoppers K K', and the duct R, provided with the branches U, extending within the said drums B, the whole constructed and arranged substantially in a manner and for the use and purpose set forth and described.

This specification subscribed by me this 26th day of July, 1875, in the presence of two subscribing witnesses.

JOSEPH SOUTER.

Witnesses:

MICHAEL J. STARK,
FRANK HIRSCH.