



US009009885B2

(12) **United States Patent**
Faasse et al.

(10) **Patent No.:** **US 9,009,885 B2**
(45) **Date of Patent:** **Apr. 21, 2015**

(54) **MODULAR WASTE DRAIN**

(75) Inventors: **Gene Earl Faasse**, Easley, SC (US);
Jeffrey H. Baldwin, Easley, SC (US);
Richard Aloysius Fahey, Jr., Greenville,
SC (US)

(73) Assignee: **T & S Brass and Bronze Works, Inc.**,
Travelers Rest, SC (US)

(*) Notice: Subject to any disclaimer, the term of this
patent is extended or adjusted under 35
U.S.C. 154(b) by 1346 days.

(21) Appl. No.: **12/428,849**

(22) Filed: **Apr. 23, 2009**

(65) **Prior Publication Data**

US 2010/0269253 A1 Oct. 28, 2010

(51) **Int. Cl.**
A01C 17/00 (2006.01)
E03C 1/22 (2006.01)

(52) **U.S. Cl.**
CPC **E03C 1/22** (2013.01)

(58) **Field of Classification Search**
CPC E03C 1/22
USPC 4/688–691, 650, 438, 441, 693, 695,
4/682, 679, 640; 251/213, 226, 318,
251/326–329; 241/30; 137/15.23, 315.29
See application file for complete search history.

(56) **References Cited**

U.S. PATENT DOCUMENTS

187,545 A * 2/1877 McEwan 4/434
1,413,858 A 5/1922 Leroi
2,597,399 A * 5/1952 Steele 4/287
4,377,274 A * 3/1983 Mayhew, Jr. 251/327

4,388,274 A * 6/1983 Rourke et al. 422/177
4,523,339 A * 6/1985 Lavoie 4/688
4,760,614 A * 8/1988 Harrison 4/255.06
5,082,247 A * 1/1992 Owens et al. 251/326
5,236,137 A * 8/1993 Coogan 241/30
5,678,802 A 10/1997 Lunder
6,058,526 A * 5/2000 Parisi et al. 4/688
6,145,136 A 11/2000 Parisi et al.
6,997,041 B1 * 2/2006 Metzger et al. 73/37

FOREIGN PATENT DOCUMENTS

CN 2304698 1/1999
WO WO 2004/079109 A1 9/2004

OTHER PUBLICATIONS

Chicago Faucets Parts List, Jul. 7, 2000.
Chicago Faucets Spec Sheet, Fitting No. 1367, May 12, 2002.
Chicago Faucets Spec Sheet, Fitting No. 1366, May 14, 2002.
Chicago Faucets web page, Commercial Drain—Commercial
Drains, 2007.
Fisher Manufacturing Company Spec Sheet, DrainKing Waste Valve
with Flat Strainer, 2007.
Fisher Manufacturing Company Spec Sheet, DrainKing Waste Valve
Rough Chrome with Flat Strainer, 2007.
Fisher Manufacturing Company Spec Sheet, DrainKing Waste Valve
with VR Flat Strainer & Knob, 2007.
Fisher Manufacturing Company Spec Sheet, DrainKing Waste Valve
Rough Chrome with VR Flat Strainer & Knob, 2007.

(Continued)

Primary Examiner — Joel Zhou
(74) *Attorney, Agent, or Firm* — Dority & Manning, P.A.

(57) **ABSTRACT**

A modular waste drain can includes at least two of the fol-
lowing separate modules that can be selectively attached and
detached from each other: an inlet assembly, an outlet assem-
bly and a knife gate valve. An additional module can be
provided by a valve guard assembly.

6 Claims, 6 Drawing Sheets

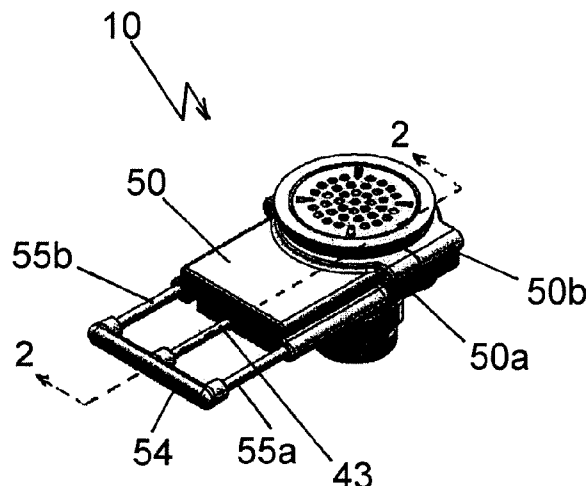

(56)

References Cited

OTHER PUBLICATIONS

Fisher Manufacturing Company Spec Sheet, DrainKing Waste Valve with Locking Basket Strainer & Overflow Body, 2007.

Fisher Manufacturing Company Spec Sheet, DrainKing Waste Valve Rough Chrome with Locking Basket Strainer & Overflow Body, 2007.

Fisher Manufacturing Company Spec Sheet, DrainKing Waste Valve with Locking Basket Strainer, 2007.

Fisher Manufacturing Company Spec Sheet, DrainKing Waste Valve Rough Chrome with Locking Basket Strainer, 2007.

Fisher Catalog (6 pages), Waste Valves, 2007.

www.plumbingsupply.com/images/fisher-drainking-components.jpg, Fisher DrainKing Components jpg webpage, 2007.

www.made-in-china.com/showroom/happyvalley/product-detail, Made-in-China.com webpage, Sink Strainer (RN-110102S), 2007.
Valterra Products, Inc. Brochure, 10" & 12" Gate Valves, Ball Valves, 2007.

Valterra Products, Inc. Brochure, RV Accessories, 2007.

CHG Component Hardware web page, Plumbing Products—Drains, 2007.

English translation of First Office Action issued by the State Intellectual Property Office of the People's Republic of China, dated May 27, 2011.

European Search Report, Sep. 1, 2010.

English translation of Decision of Rejection issued by the State Intellectual Property Office of the People's Republic of China, dated Mar. 31, 2012.

* cited by examiner

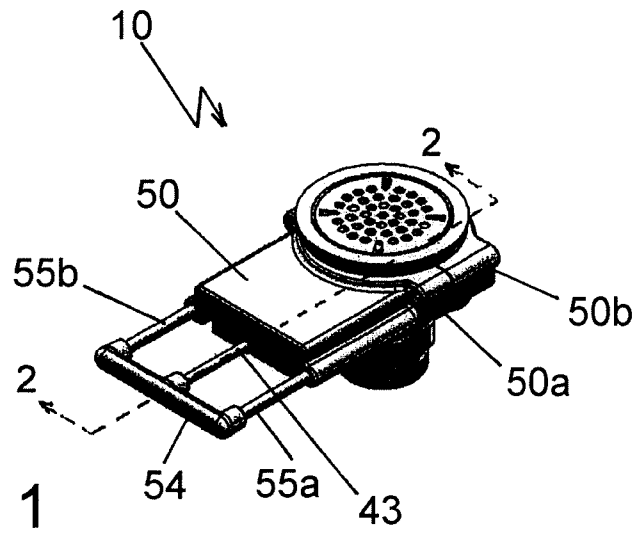

Fig. 1

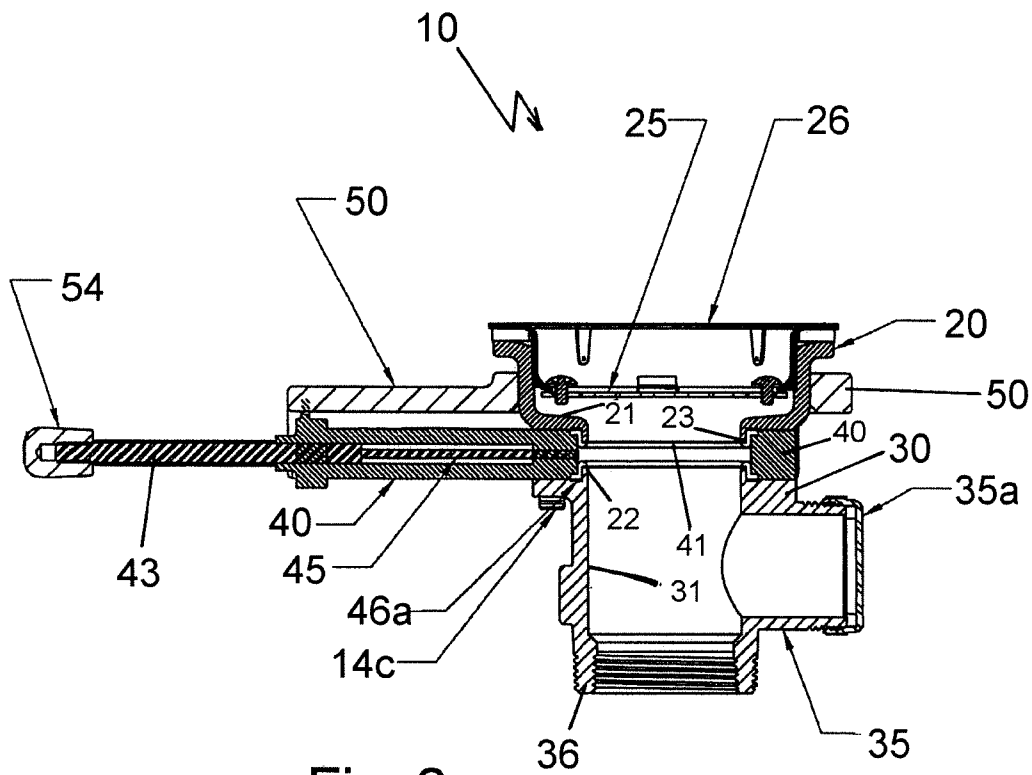

Fig. 2

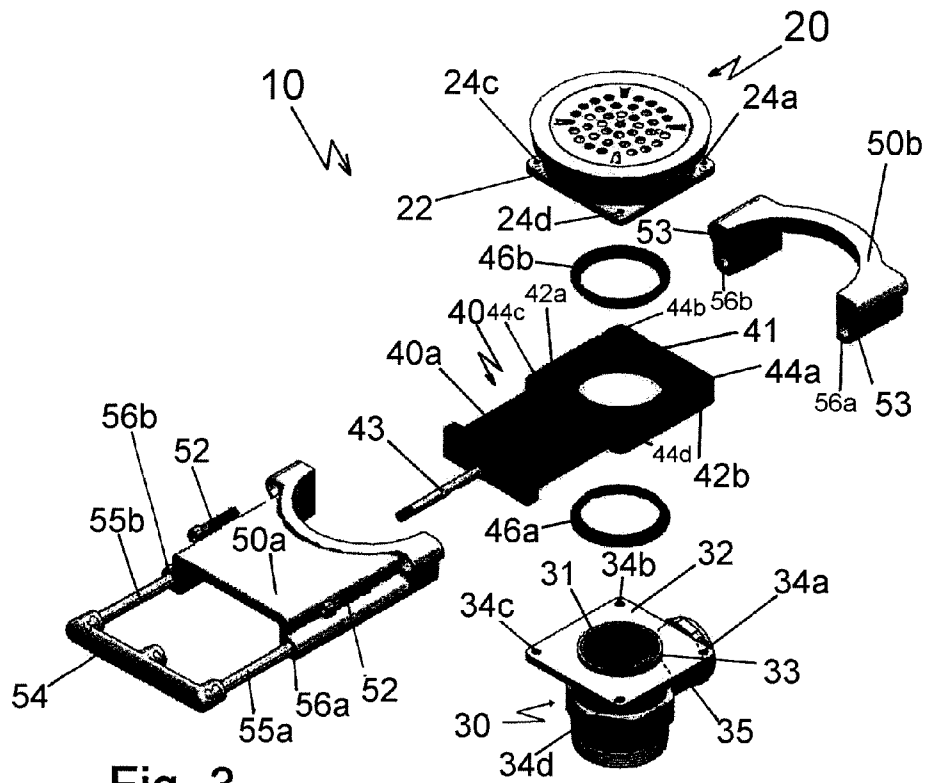

Fig. 3

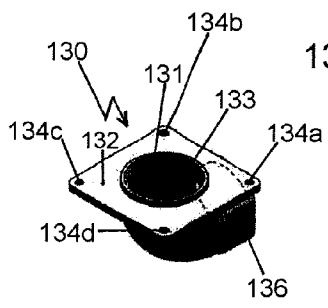
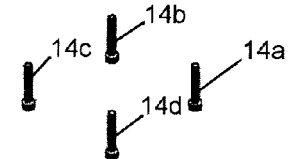

Fig. 3A

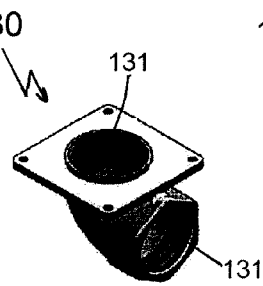

Fig. 3B

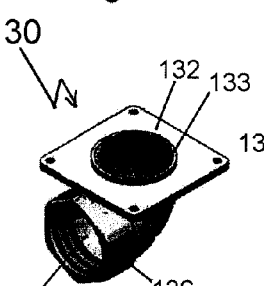

Fig. 3C

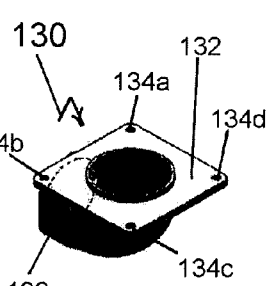
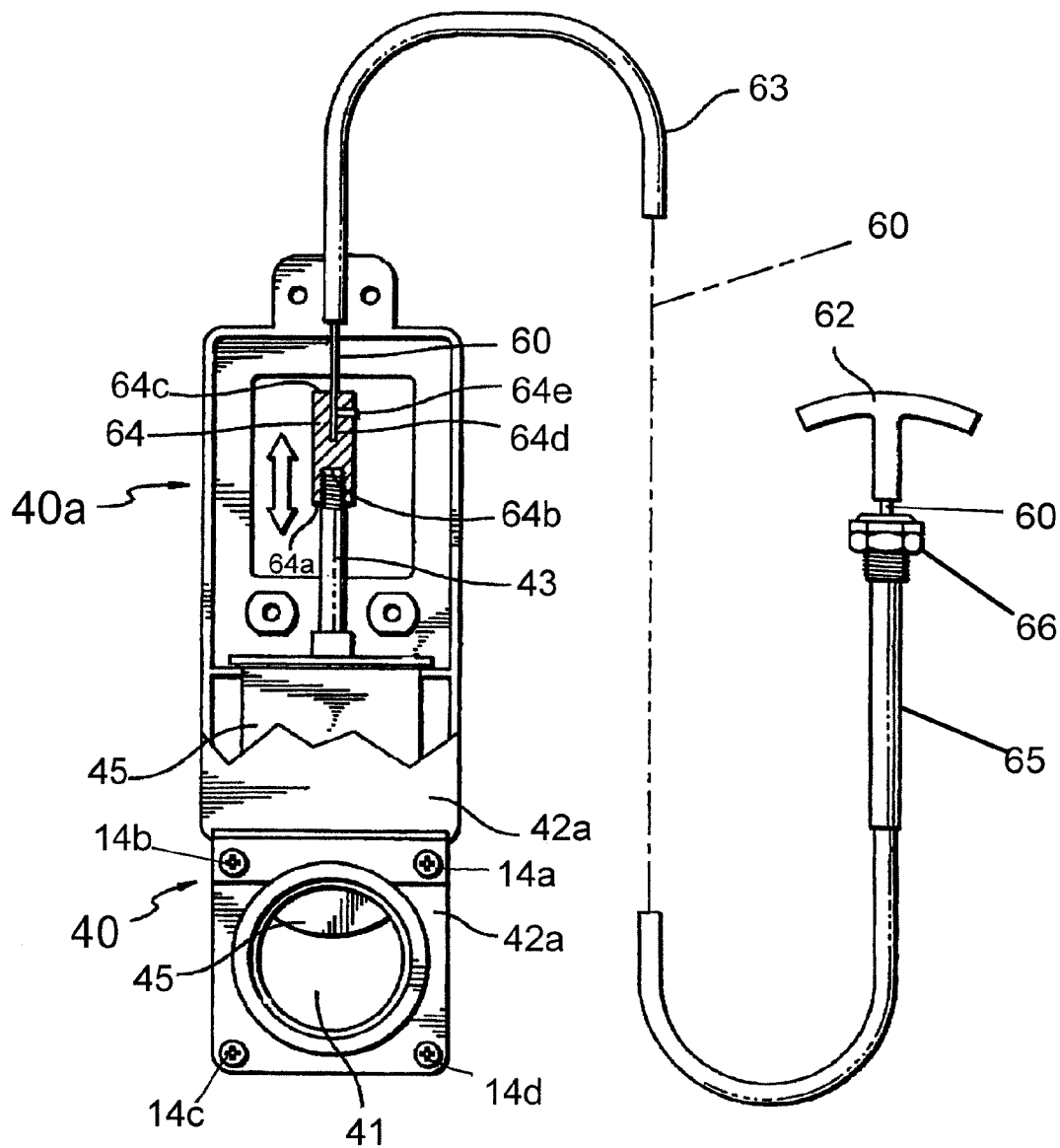

Fig. 3D

Fig. 4



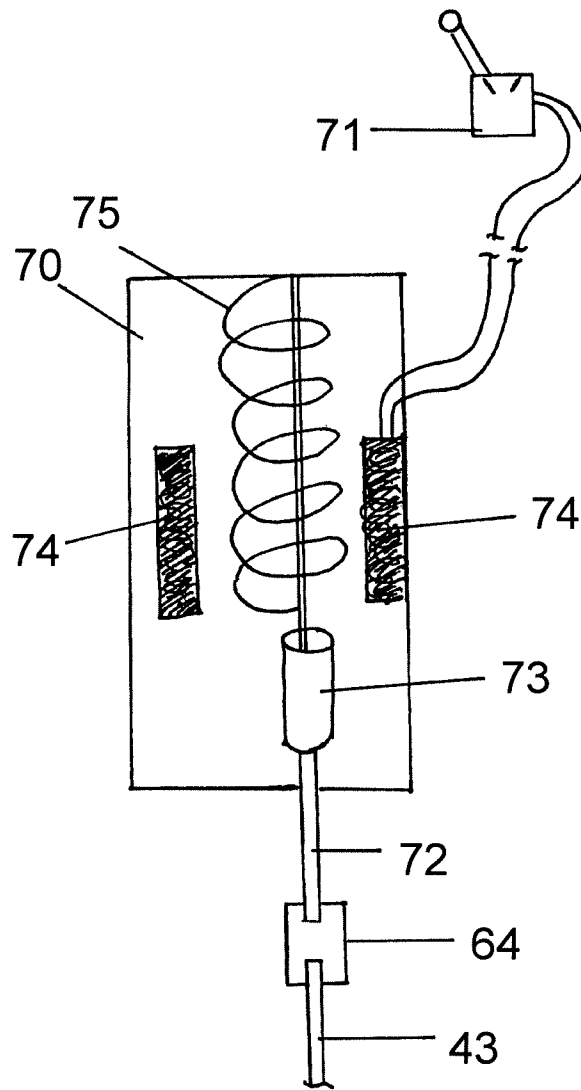
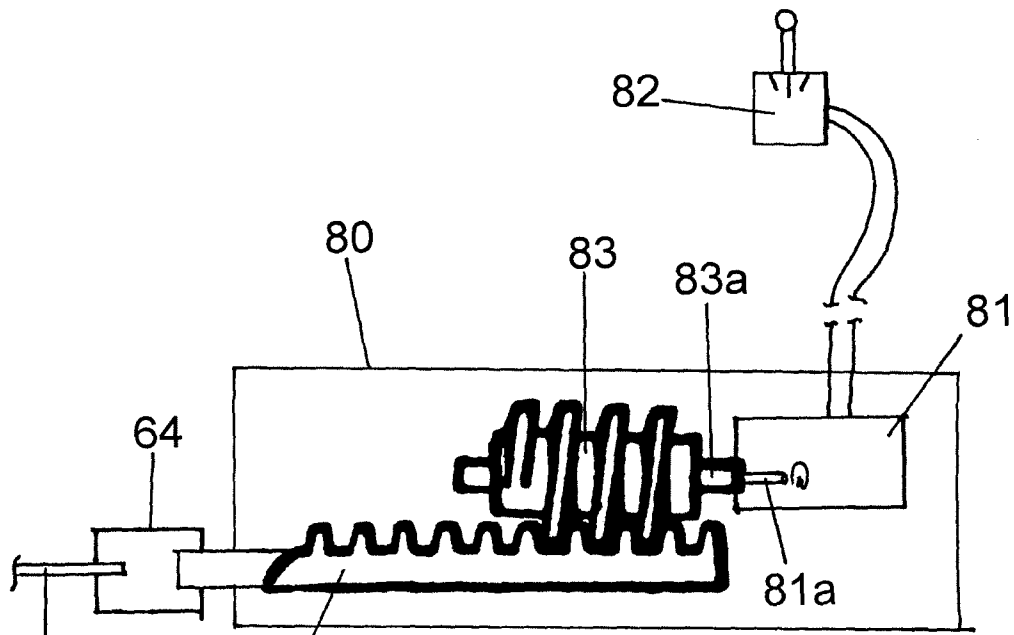

Fig. 4A



84 Fig. 4B

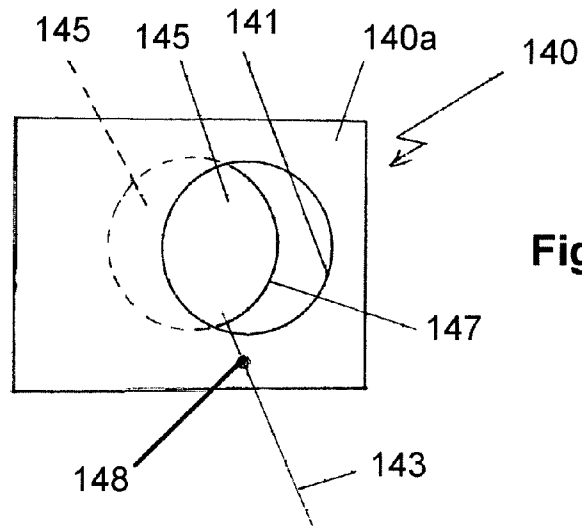

Fig. 4C

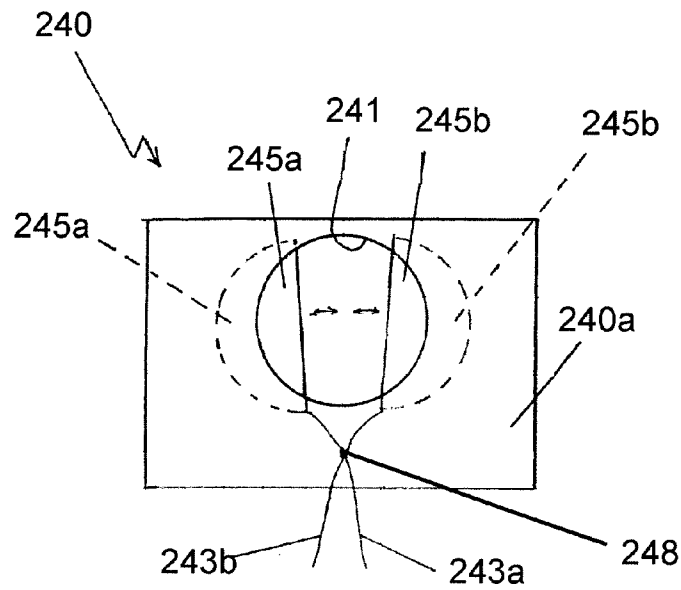

Fig. 4D

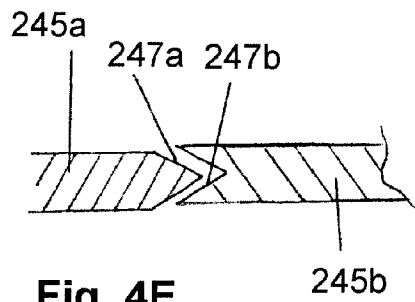

Fig. 4E

1

MODULAR WASTE DRAIN**CROSS-REFERENCE TO RELATED APPLICATIONS**

N/A

STATEMENT REGARDING FEDERALLY SPONSORED RESEARCH OR DEVELOPMENT

N/A

BACKGROUND OF THE INVENTION

A waste drain used in commercial food service applications is typically installed in large commercial sinks as the sink drain. Conventional waste drains typically use a one piece body construction that is specific to an inlet/outlet combination. Each significantly different inlet and/or outlet sink connection requires a different waste drain specifically tailored to that particular inlet and/or outlet connection. The different combinations mean that a substantial inventory must be maintained.

To open and close the conventional waste drain, one might find a "ball" valve or a "cylinder valve or a "rotor" valve or a "pop-up" valve permanently installed in the one piece body of the drain. Each of these valves would be actuated only by a handle directly connected to the waste drain, and so access to the handle was often inconvenient due to obstructions in the environment of the drain. Overflow ports for a conventional waste drain are typically located on the opposite side of the waste drain from the handle, and this location cannot be varied during installation of the drain and so also might become inconveniently disposed. Moreover, ball valves and cylinder valves are relatively expensive.

The size of the passage through the valve of a conventional waste drain is typically less than the size of the passage through the connecting pipes and thus limits the passage of drain cleaning equipment through the conventional waste drain. Where the drain includes a cylinder valve, the mechanics and assembly of the parts of such valves further limit the size of the passage of the valve body, thereby further limiting the use of drain cleaning equipment. The same is true of some drains that include a ball valve.

OBJECTS AND SUMMARY OF THE INVENTION

It is a principal object of the present invention to provide a modular waste drain that can be configured for installation in any inlet/outlet combination, including custom applications.

It is another principal object of the present invention to provide a modular waste drain that can be reconfigured while the drain is still installed in the sink.

It is a further principal object of the present invention to provide a modular waste drain with inlet assemblies and outlet assemblies that are indexable for multiple positions to allow ease of connection, routing of plumbing or positioning of the handle.

It is still another principal object of the present invention to provide a modular waste drain with outlet assemblies that are indexable for multiple positions of the overflow port.

It is a still further principal object of the present invention to provide a modular waste drain that employs a knife gate valve, which is compact in size, durable, economical and allows for easy maintenance and replacement of a component that is unacceptably damaged or worn.

2

It is yet another principal object of the present invention to provide a modular waste drain that allows for an increase in the flow through rate relative to conventional commercial waste drains.

5 It is an additional principal object of the present invention to provide a modular waste drain with valve gate member having a sharp edge that will slice through some obstructions that extend across the valve opening when the valve gate member is moving from the open position to the closed position.

10 It is an additional further principal object of the present invention to provide a modular waste drain with an unobstructed passage through the waste drain for easy passage of drain cleaning equipment.

15 It is another additional principal object of the present invention to provide a modular waste drain with a valve body passage that is greater than the current drain pipe size typically connected to waste drains.

20 It is yet a further principal object of the present invention to provide a modular waste drain configured to allow it to be opened and closed by an actuating assembly that is accessible remotely from the waste drain.

25 It is yet an additional principal object of the present invention to provide a modular waste drain that can be remotely actuated by such means that include one or more of mechanical apparatus, electric motor and electric solenoid.

30 It is a still additional principal object of the present invention to provide a modular waste drain with a handle guard that protects the valve handle and/or valve body from accidental damage or abuse.

35 It is yet a still further principal object of the present invention to provide a modular waste drain with a handle guard that is designed to withstand loads and impact forces that would typically damage and impair the actuation of the valve in a conventional waste drain.

40 Additional objects and advantages of the invention will be set forth in part in the description that follows, and in part will be obvious from the description, or may be learned by practice of the invention. The objects and advantages of the invention may be realized and attained by means of the instrumentalities and combinations particularly pointed out in the appended claims.

45 To achieve the objects and in accordance with the purpose of the invention, as embodied and broadly described herein, a presently preferred embodiment of a modular waste drain includes at least the following separate modules that can be selectively attached and detached from each other: an inlet assembly, an outlet assembly and a knife gate valve. In an alternative preferred embodiment, an additional module is provided by a valve guard assembly. In a further alternative preferred embodiment, the knife gate valve need only be detachably connected to at least one of the inlet assembly and the outlet assembly.

50 The inlet assembly defines an inlet passage, and the outlet assembly defines an outlet passage. The knife gate valve has a valve body that defines a valve opening, and the waste drain defines a waste passage that includes the inlet passage, the outlet passage and the valve opening. The valve body of the knife gate valve can be detachably connected to the inlet assembly and detachably connected to the outlet assembly. The knife gate valve includes a gate member that is disposed within the valve body and configured to be selectively slidable between a closed position and an open position, wherein the valve opening is completely closed in the closed position and completely open in the open position. A valve handle has one end connected to the gate member and an opposite end selectively moveable with respect to the valve body. A valve

guard assembly can include a cross bar that can be connected to the selectively moveable end of the handle. Alternatively, the valve guard assembly can include an actuating assembly that can have one end connected to the selectively moveable end of the handle and an opposite end remotely disposed from the waste drain and that can be used by the operator to effect remote opening and closing of the knife gate valve.

The accompanying drawings, which are incorporated in and constitute a part of this specification, illustrate at least one presently preferred embodiment of the invention as well as some alternative embodiments. These drawings, together with the description, serve to explain the principles of the invention but by no means are intended to be exhaustive of all of the possible manifestations of the invention.

BRIEF DESCRIPTION OF THE DRAWINGS

FIG. 1 is an elevated perspective view of a presently embodied modular waste drain of the present invention.

FIG. 2 is a cross-sectional view taken along the direction of the arrows shown designated 2-2 in FIG. 1.

FIG. 3 is an elevated perspective assembly view of the embodiment of FIGS. 1 and 2.

FIG. 3A is an alternative embodiment of a component of the present invention.

FIG. 3B is an alternative embodiment of a component of the present invention.

FIG. 3C is another alternative embodiment of a component of the present invention.

FIG. 3D is a further alternative embodiment of a component of the present invention.

FIG. 4 is a top plan view with portions cut away of an alternative embodiment of a component of the present invention.

FIG. 4A schematically presents alternative embodiments of components of an embodiment of the present invention.

FIG. 4B schematically presents alternative embodiments of components of an embodiment of the present invention.

FIG. 4C schematically presents alternative embodiments of components of an embodiment of the present invention.

FIG. 4D schematically presents alternative embodiments of components of an embodiment of the present invention.

FIG. 4E schematically presents alternative embodiments of components of an embodiment of the present invention.

DETAILED DESCRIPTION OF THE PREFERRED EMBODIMENTS

Reference now will be made in detail to the presently preferred embodiments of the invention, one or more examples of which are illustrated in the accompanying drawings. Each example is provided by way of explanation of the invention, which is not restricted to the specifics of the examples. In fact, it will be apparent to those skilled in the art that various modifications and variations can be made in the present invention without departing from the scope or spirit of the invention. For instance, features illustrated or described as part of one embodiment, can be used on another embodiment to yield a still further embodiment. Thus, it is intended that the present invention cover such modifications and variations as come within the scope of the appended claims and their equivalents. The same numerals are assigned to the same components throughout the drawings and description.

A presently preferred embodiment of the modular waste drain is shown in FIGS. 1-3 and is represented generally by the numeral 10. As shown in FIG. 3 for example, the modular

waste drain 10 includes at least the following separate modules that can be selectively attached and detached from each other: an inlet assembly 20, an outlet assembly 30 and a knife gate valve 40. In an alternative embodiment, an additional module can be provided by a valve guard assembly 50 as shown in FIGS. 1 and 2 for example. In a further alternative embodiment, the knife gate valve need only be detachably connected to at least one of the inlet assembly and the outlet assembly.

As shown in FIG. 2, the inlet assembly 20 defines an inlet passage 21 internally thereof, and the outlet assembly 30 defines an outlet passage 31 internally thereof. As shown in FIGS. 2, 3 and 4, the knife gate valve 40 defines a valve opening 41. Similarly, as shown schematically in FIGS. 4C and 4D, the respective knife gate valve 140, 240 defines a valve opening 141, 241. As shown in FIG. 2 for example, the valve opening 41 is disposed between the inlet passage 21 and the outlet passage 31, and thus the modular waste drain 10 defines a waste passage for the flow of waste therethrough and that includes the inlet passage 21, the outlet passage 31 and the valve opening 41. Accordingly, the respective valve opening 41, 141, 241 is positioned so that the respective valve 40, 140, 240 can be operated to control the flow of waste that is allowed to pass through the modular waste drain 10. Moreover, as shown in FIG. 2 for example, the valve opening 41 is at least as wide as the outlet passage 31, and thus allows for an increase in the flow through rate relative to conventional commercial waste drains.

In accordance with the present invention, the knife gate valve can be detachably connected to at least one of the inlet assembly and the outlet assembly. Desirably, the knife gate valve can be detachably connected to both of the inlet assembly and the outlet assembly. As shown in FIG. 3, each of the inlet assembly 20 and the outlet assembly 30 is provided with a respective attachment flange 22, 32. As shown in FIG. 3, the attachment flange 22 of the inlet assembly 20 is defined as a peripherally extending flange at the outlet 23 (FIG. 2) of the inlet passage 21. As shown in FIG. 3, the attachment flange 32 of the outlet assembly 30 is defined as a peripherally extending flange at the inlet 33 of the outlet passage 31. As shown in FIG. 3, the knife gate valve 40 includes a valve body 40a. Each of the respective attachment flanges 22, 32 desirably is configured to mate snugly with an opposite surface on the topside 42a and the underside 42b of the valve body 40a around the valve opening 41 of the knife gate valve 40.

Each of the respective attachment flanges 22, 32 desirably is configured with the same shape, but need not be identically configured so long as the opposing surfaces are designed to mate snugly to each other. Moreover, as shown in FIG. 3, at least one attachment hole 24a, 34a defined in each respective attachment flange 22, 32 is configured to be aligned with a corresponding attachment hole 24a, 34a of the other flange 22, 32 and aligned with a corresponding attachment hole 44a through the body 40a of the knife gate valve 40. Desirably, each of a plurality of respective attachment holes 24a, 24b, 24c, 24d defined in the attachment flange 22 of the inlet assembly 20 is aligned with a corresponding one of the respective attachment holes 34a, 34b, 34c, 34d defined through the attachment flange 32 of the outlet assembly 30 and with a corresponding one of the respective attachment holes 44a, 44b, 44c, 44d defined through the valve body 40a.

At least one selectively detachable connector is configured to bias the knife gate valve 40 against the inlet assembly 20 and against the outlet assembly 30. As shown in FIGS. 2 and 3, the at least one selectively detachable connector can include a screw 14a, and desirably additional screws 14b, 14c, 14d beyond the one screw 14a are provided as shown in

FIG. 3. Desirably, each screw **14a**, **14b**, **14c**, **14d** can be passed through one of the corresponding aligned attachment holes **34a**, **34b**, **34c**, **34d** in the outlet assembly **30** and thence passed through one of the corresponding aligned attachment holes **44a**, **44b**, **44c**, **44d** in the valve body **40a** of the knife gate valve **40** and threaded into the corresponding aligned attachment hole **24a**, **24b**, **24c**, **24d** in the inlet assembly **20** so that installation of the modular waste drain **10** can be accomplished from beneath the sink. Alternatively, the at least one selectively detachable connector can include a bolt that is passed through the attachment holes in the attachment flanges **22**, **32** and the valve body **40a** of the knife gate valve, and a threaded nut could receive the threaded end of each bolt.

Details of the construction and operation of a suitable knife gate valve **40** are disclosed in U.S. Pat. No. 5,678,802, which is hereby incorporated herein by this reference for all purposes. As shown in FIGS. **2** and **3**, the knife gate valve **40** includes a valve handle **43** that has one end connected to a valve gate member **45**. The valve gate member **45** is disposed within the valve body **40a** and is configured to be selectively slidable between a closed position and an open position. In the view shown in FIG. **2**, the valve gate **45** is disposed in the open position whereby the valve opening **41** is completely open. In the view shown in FIG. **4** for example, the valve gate member **45** is partially occluding the valve opening **41**. Thus, the valve handle **43** that has one end connected to the valve gate member **45** can be selectively moveable in a straight line to control opening and closing of the knife gate valve **40**. In the embodiment shown in FIGS. **1-4** for example, straight line movements of the valve handle **43** effect sliding movements of the valve gate member **45** between the open position and the closed position.

In one alternative embodiment of the knife gate valve schematically shown in FIG. **4C**, a valve handle **143** is selectively moveable about a pivot point **148** to control opening and closing of the knife gate valve **140**. As schematically shown in FIG. **4C**, the valve body **140a** defining the valve opening **141** desirably can be configured to permit the valve gate member **145** attached to the valve handle **143** to open and close with a pivoting movement as in a pendulum movement.

In another alternative embodiment of the knife gate valve **240** schematically shown in FIG. **4D**, each of a pair of valve handles **143a**, **143b** is selectively moveable about a pivot point **248** to control opening and closing of the knife gate valve **240**. As schematically shown in FIG. **4D**, the valve body **240a** defining the valve opening **241** desirably can be configured to permit a scissors movement of each of two pieces **245a**, **245b** forming the valve gate. Each respective piece **245a**, **245b** of the valve gate is connected to its own respective valve handle **243a**, **243b**. As schematically shown in FIGS. **4D** and **4E**, the two pieces **245a**, **245b** forming the valve gate pivot to separate to open and come together to close as reminiscent of the movements of the blades of a scissor.

Each of the elements forming the valve gate member **45**, **145**, **245a**, **245b** desirably is formed of a flat plate of stainless steel having a thickness on the order of about one sixteenth of an inch to about three thirty-seconds of an inch. As shown in FIG. **4**, the leading edge **47** of the valve gate member **45** is desirably formed as a sharp edge that will slice through some obstructions that extend across the valve opening **41** when the valve gate member is moving from the open position to the closed position. The same is true for the leading edge **147** of the valve gate member **145** schematically shown in FIG. **4C** and the leading edges **247a**, **247b** of the pieces **245a**, **245b** of the valve gate member shown schematically in FIG. **4E**.

In order to guard against a leading edge (**47**, **147**, **247a**, **247b**) of the valve gate member severing a worker's finger

that might be placed inadvertently across the valve opening during movement of the valve gate into the closed position, as shown in FIG. **2** for example, an inlet guard **25** can be provided for the inlet assembly **20**. The inlet guard **25** desirably is detachably connected to the inlet assembly **20** and disposed across the inlet passage **21** of the inlet assembly **20**, thereby preventing a worker from placing a digit into the path of the valve gate member. Additionally, as shown in FIGS. **1-3**, a removable flat or basket strainer **26** can be attached to the externally projecting open end of the inlet assembly **20**.

In accordance with an alternative preferred embodiment of the present invention, the modular waste drain desirably includes a valve guard assembly that is connected to the knife gate valve and disposed to shield the knife gate valve from external impacts. As shown in FIG. **2**, the valve guard assembly **50** desirably is connected to the inlet assembly **20**, which is received through an opening defined internally of the guard member **50**. As shown in FIG. **3**, the valve guard assembly includes a front end **50a**, a back end **50b** and at least one connecting element that selectively holds the front end **50a** to the back end **50b**. Each of the front end **50a** and the back end **50b** desirably is formed of a strong, rigid material that can carry out the protective function of the valve guard assembly **50**, and examples of suitable materials include aluminum, zinc alloy suitable for die casting, and bronze. As shown in FIG. **3**, one embodiment of a connecting element can be an elongated connecting screw **52** that has one end threaded into a threaded aperture **53** that is defined within the back end **50b** of the guard member **50**. Desirably, a pair of elongated connecting screws **52** can be employed with one connecting screw **52** being disposed to each opposite side of the guard member **50**. Each of the two screws **52** shown in FIG. **3** desirably can be fitted with a head that receives a tool non-rotatably therein. An example of such a tool would be an Allen wrench. Tightening of the screws **52** would result in drawing the front end **50a** against the back end **50b** so that the inlet assembly **20** would be secured between the front end **50a** and the back end **50b** of the valve guard assembly **50** as shown in FIG. **2** for example.

As shown in FIGS. **1-3**, the valve guard assembly **50** desirably includes a crossbar **54** that is connected to the end of the valve handle **43** opposite the end of the valve handle **43** that is connected to the valve gate member **45**. As shown in FIGS. **1-3**, the valve guard assembly **50** desirably further includes at least one support rod **55a** disposed parallel to the valve handle **43** and connected to the crossbar **54**. Desirably, a support rod **55a** or **55b** is disposed to each side of the valve handle **43**, and the two support rods **55a**, **55b** lie in a common plane with the valve handle **43**. Each of the support rods **55a** or **55b** desirably is connected to a respective opposite end of the crossbar **54**. Additionally, as shown in FIG. **3** for example, for each support rod **55a** or **55b** a respective elongated channel **56a** or **56b** is defined within the main body of the valve guard assembly **50** and configured to receive the support rod therein. As shown in FIG. **3** for example, each respective elongated channel **56a** or **56b** is defined within both the front end **50a** and the back end **50b** of the main body of the valve guard assembly **50**. Each support rod **55a**, **55b** is slidable selectively into and out of its respective channel **56a**, **56b**. Thus, even when the valve handle **43** is positioned so that the valve opening **41** is completely open and the valve handle **43** is fully extended out of the knife gate valve **40**, the support rods **55a**, **55b** and the cross bar **54** of the valve guard assembly **50** still partially protect the valve handle **43** from impacts coming from either opposite side and to one end of the valve handle **43**.

Provision desirably can be made for remote actuation of the opening and closing of the modular waste drain of the present

invention. A remote actuator assembly desirably is connected to the knife gate valve and configured to permit opening and closing of the valve from a location remote from the waste drain. In one embodiment of the remote actuator assembly shown in FIG. 4 for example, an actuating cable 60 can be provided with one end connected to the valve handle 43. An opposite end of the actuating cable 60 desirably is remotely disposed from the end of the actuating cable 60 that is connected to the valve handle 43. The force needed to operate the remote actuator assembly is manually supplied by the user. As shown in FIG. 4, a manual grip 62 desirably is connected to the remotely disposed opposite end of the cable 60 so that when the operator pulls on the manual grip 62, the cable 60 is withdrawn from a surrounding cable sleeve 63 and pulls on the valve handle 43 in a manner that opens the valve opening 41. As shown in FIG. 4, the end of the actuating cable 60 that is connected to the manual grip 62 can be passed through a rigid tube 65 having a fixture 66 for installation to the sink so as to deploy the manual grip 62 where the operator has easy access to the manual grip 62.

As shown in FIG. 4, one end 64a of a rigid adapter 64 can be provided with a threaded opening 64b to receive a threaded end of the valve handle 43, while the opposite end 64c of the rigid adapter 64 can be provided with a conduit 64d that receives the end of the cable 60 and retains the end of the cable 60 therein by means of a set screw 64e. When the valve opening 41 is open, pushing on the manual grip 62 pushes the valve handle 43 in a manner that closes the valve opening 41. When the valve opening 41 is closed, pulling on the manual grip 62 pulls the valve handle 43 in a manner that opens the valve opening 41. Moreover, in an alternative embodiment, a linkage (not shown) can be introduced between the cable 60 and the valve handle 43 so that pushing on the manual grip 62 opens the valve opening 41 and pulling on the manual grip 62 closes the valve opening 41.

In other embodiments of the remote actuator assembly shown schematically in FIGS. 4A and 4B for example, an electromechanical actuating assembly can be provided with electrical power supplying the force needed to operate the remote actuator assembly. The electromechanical actuating assembly can be connected to the valve handle 43 by means of any connection mechanism, which might include a rigid adapter 64. As shown schematically in FIG. 4A for example, the electromechanical actuating assembly can include a solenoid actuator 70 that can be electrically actuated by an on/off switch 71 that is remotely located from the waste drain. The switch 71 can be mounted on the sink for example. One end of the solenoid stem 72 can be connected to the valve handle 43, and the opposite end of the solenoid stem 72 can be connected to the armature 73. When the switch 71 is closed, current flows through the coil 74 that creates a magnetic field pulling the armature 73 into the space within the coil and force-loading the reset spring 75. This linear motion also pulls the valve handle 43 toward the actuator 70 and depending on the configuration, either opens or closes the knife gate valve 40. When the switch 71 is open, current is cut off from the coil 74 and the magnetic field disappears, thus allowing the reset spring 75 to move the armature 73 away from the coil 74 (the condition shown in FIG. 4A) and also pushing the valve handle 43 away from the actuator 70.

As shown schematically in FIG. 4B for example, another embodiment of an electromechanical actuating assembly can include an actuator 80 with an electric motor 81. The electric motor 81 that operates the electromechanical actuator can be electrically actuated by a switch 82 that is remotely located from the waste drain. The switch 82 can be a three position switch (forward on-off-reverse on) mounted on the sink for

example. Any of a number of different ways can be provided to convert the rotational motion of the armature of a motor into linear translational motion. As shown schematically in FIG. 4B for example, the shaft 83a of a worm screw 83 can be connected to the armature 81 a of the motor 81. One end of a rack 84 that has teeth rotatably engaged by the worm screw 83 can be connected to the valve handle 43. When the switch 82 is closed, current flows to the motor 81 and rotates the armature 81 a in either the clockwise or counterclockwise direction depending on the position of the switch 82. Rotation of the armature 81a causes the worm screw 83 to rotate in the same direction. Rotation of the worm screw 83 linearly moves the rack 84 either toward or away from the actuator 80. Depending on the configuration, this linear motion of the rack 84 also either pulls the valve handle 43 toward the actuator 80 or pushes the valve handle 43 away from the actuator 80 and either moves the valve gate member 45 toward the open position or toward the closed position of the knife gate valve 40. When the switch 82 is open, current is cut off from the motor 81 and the linear movement of the valve handle 43 stops, thus allowing the operator to position the valve gate member 45 at an intermediate location so that the valve opening 41 is partially open and partially closed.

As shown in FIG. 2, at least one selectively removable seal 46a is desirably disposed between the knife gate valve 40 and at least one of the inlet assembly 20 and the outlet assembly 30. Desirably, as shown in FIGS. 2 and 3, one seal 46a is disposed to rest on the upper surface of the attachment flange 32 of the outlet assembly 30 surrounding the inlet 33 of the outlet passage 31 to thereby make water tight sealing contact with the underside 42b of the knife gate valve 40 and in the region of the valve body 40a surrounding the valve opening 41. This first seal 46a butts against the inlet 33 of the outlet passage 31 of the outlet assembly 30.

As schematically shown in FIG. 3, a second seal 46b desirably is disposed to rest on the lower surface of the attachment flange 22 of the inlet assembly 20 to thereby make water tight sealing contact with the topside 42a of the knife gate valve 40 and in the region of the valve body 40a surrounding the valve opening 41. This second seal 46b butts against the outlet 23 of the inlet passage 21 of the inlet assembly 20. Each of these seals 46a, 46b is desirably formed of a resiliently deformable, water impermeable material such as rubber. These seals 46a, 46b can be replaced easily when the outlet assembly 30 is detached from the valve body 40a of the knife gate valve 40 and the knife gate valve 40 is detached from the inlet assembly 20.

As shown in FIG. 2, the outlet assembly 30 desirably includes an overflow port 35 disposed downstream of the inlet 33 of the outlet passage 31 and upstream of the discharge end 36 of the outlet passage 31. The overflow port 35 desirably extends in a direction that is at a right angle to the direction of the flow through the outlet passage 31 of the outlet assembly 30. The overflow port 35 desirably can be externally threaded to receive a cap 35a that is screwed onto the end of the overflow port 35 and seals the overflow port 35. The cap 35a can be unscrewed and removed when it is desired to open the overflow port 35. Alternatively, the overflow port 35 desirably can be internally threaded to receive a threaded plug that can be screwed into the end of the overflow port 35 to seal the overflow port 35 and selectively unscrewed and removed when it is desired to open the overflow port 35.

As shown in FIG. 2, the discharge end 36 of the outlet assembly 30 desirably can be internally threaded to receive a connecting pipe. Desirably, the discharge end 36 of the outlet assembly 30 also can be externally threaded to be connected to a connecting pipe. Moreover, though not shown, a threaded

plug or a threaded cap can be screwed, respectively, into the internal threads or onto the external threads of the discharge end **36** of the outlet assembly **30** if it is desired to connect the outlet assembly **30** through the overflow port **35** to the sewer line for example.

An alternative embodiment of an outlet assembly **130** is shown in each of FIGS. **3A**, **3B**, **3C** and **3D** in four successive different 90 degree orientations. This embodiment **130** of the outlet assembly shown in each of FIGS. **3A**, **3B**, **3C** and **3D** is configured with a right angle elbow between the inlet **133** of the outlet passage **131** and the discharge end **136**. This embodiment of the outlet assembly **130** is similarly provided with a suitable attachment flange **132** that desirably is identically configured as the attachment flange of the embodiment of the outlet assembly **30** shown in FIG. **3** and thus is easily substituted therefor.

Similarly, because the embodiment of an outlet assembly **30** shown in FIG. **3** has four connector holes **34a**, **34b**, **34c**, **34d**, the outlet assembly **30** can be disposed in any of four different orientations with the overflow port **35** facing any one of four different directions. The number of orientations for directing the overflow port **35** is equivalent to the respective number of symmetrically spaced respective connector holes **24a**, **24b**, **24c**, **24d**, etc., **34a**, **34b**, **34c**, **34d**, etc. that can be aligned in each of the respective attachment flanges **22**, **32**, of the inlet assembly **20** and the outlet assembly **30** and the respective connector holes **44a**, **44b**, **44c**, **44d**, etc. of the valve body **40a** of the knife gate valve **40**. When installing the modular waste drain **10**, the overflow port **35** in the embodiment of FIGS. **2** and **3** and the discharge end **136** of the embodiment of any of FIGS. **3A**, **3B**, **3C** and **3D** can be oriented in any of the possible orientations determined by the number of aligned and symmetrically arranged respective connector holes in the respective attachment flanges.

Because the knife gate valve **40** is detachably connected to the inlet assembly **20** and detachably connected to the outlet assembly **30**, the modular waste drain **10** of the present invention can be reconfigured and/or repaired while the drain **10** is still installed in the sink. Replacing the seals **46a**, **46b** when they become degraded is a relatively simple operation. Moreover, a different inlet assembly **20** and/or outlet assembly **30** can be installed relatively simply.

While at least one presently preferred embodiment of the invention has been described using specific terms, such description is for illustrative purposes only, and it is to be

understood that changes and variations may be made without departing from the spirit or scope of the following claims.

What is claimed is:

1. A modular waste drain assembly for a vessel having a drain opening that communicates with a drain line through which the vessel discharges matter to a sewer, comprising: an inlet assembly defining an inlet passage, the inlet assembly being configured to fit into the drain opening of the vessel; an outlet assembly defining an outlet passage, the outlet assembly having a discharge end configured for connection to the drain line; and a knife gate valve having a valve opening disposed between the inlet passage and the outlet passage, the knife gate valve defining a valve body having a first end and a second end, the first end being detachably connected to the inlet assembly by at least one selectively detachable connector and the second end being detachably connected to the outlet assembly; a valve guard assembly connected to the knife gate valve and disposed to shield the knife gate valve from external impacts.

2. A modular waste drain as in claim 1, further comprising: a valve guard assembly connected to the knife gate valve and disposed to shield the knife gate valve from external impacts.

3. A modular waste drain as in claim 1, wherein the valve guard assembly is connected to the inlet assembly.

4. A modular waste drain as in claim 1, wherein the valve guard assembly includes a front end, a back end and at least one connecting element that selectively holds the front end to the back end.

5. A modular waste drain as in claim 1, wherein the at least one connecting element is a screw.

6. A modular waste drain as in claim 1, wherein: the knife gate valve includes a valve handle that is selectively moveable to effect opening and closing of the knife gate valve; the valve guard assembly includes a cross bar connected to the valve handle; the valve guard assembly further includes at least one support rod disposed parallel to the valve handle and connected to the cross bar; and the valve guard assembly defines an elongated channel receiving the support rod therein and wherein the support rod is slidable selectively into and out of the channel.

* * * * *