

(No Model.)

O. R. LEHDORFF.

REVERSIBLE BACK FOR CAR SEATS.

No. 360,231.

Patented Mar. 29, 1887.

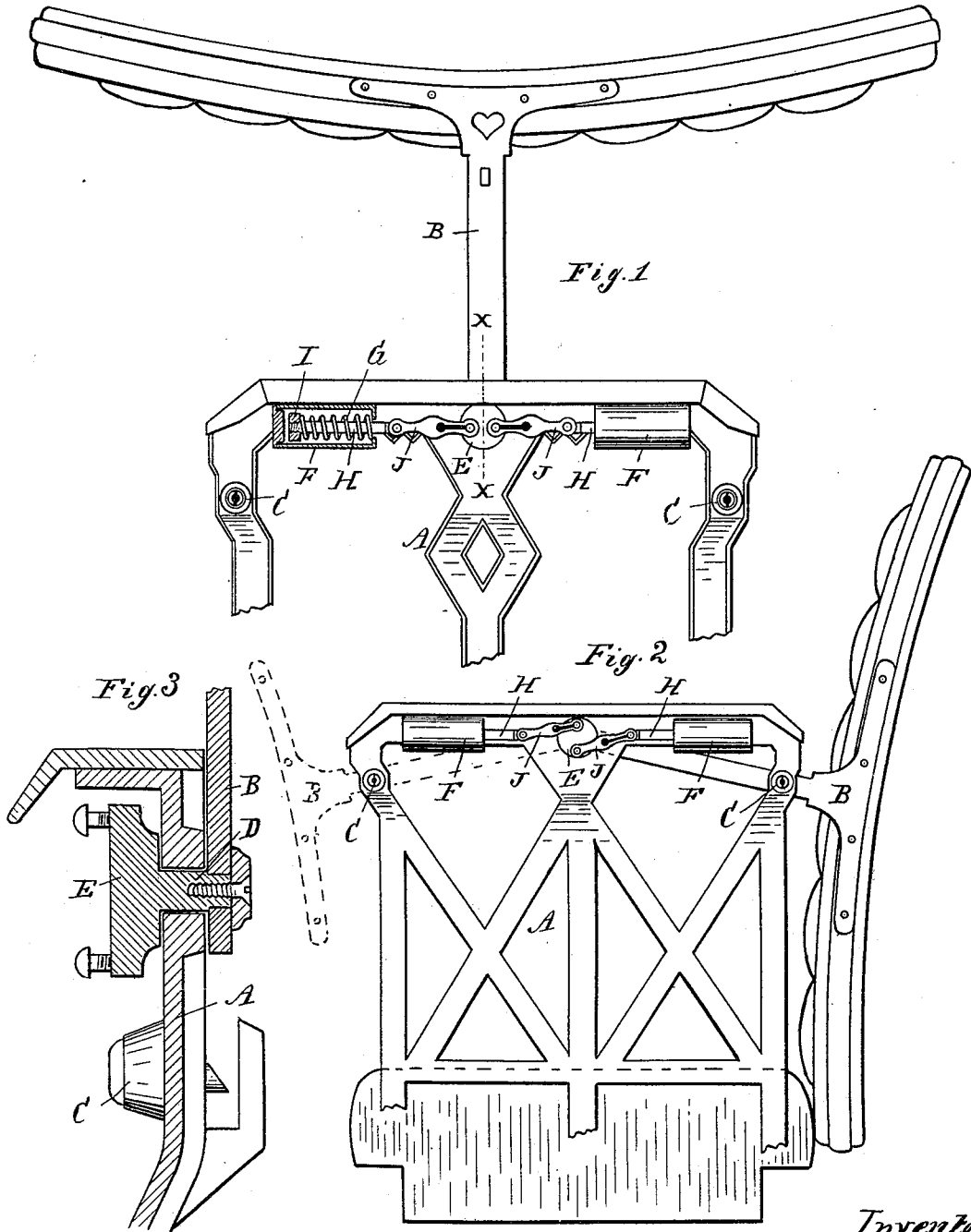

Attest:
John Schuman.
[Signature]

Inventor:
Oscar R. Lehdorff.
by his atty
[Signature]

UNITED STATES PATENT OFFICE.

OSCAR R. LEHNDORFF, OF DETROIT, MICHIGAN.

REVERSIBLE BACK FOR CAR-SEATS.

SPECIFICATION forming part of Letters Patent No. 360,231, dated March 29, 1887.

Application filed March 11, 1886. Serial No. 194,773. (No model.)

To all whom it may concern:

Be it known that I, OSCAR R. LEHNDORFF, of Detroit, in the county of Wayne and State of Michigan, have invented new and useful Improvements in Reversible Car-Seats, (Backs;) and I do hereby declare that the following is a full, clear, and exact description thereof, reference being had to the accompanying drawings, which form a part of this specification.

This invention relates to certain new and useful improvements in the construction of car-seats, the object of the invention being to so connect the frame of the back with the leg or seat-frame that all danger and reasonable possibility of breaking the back-irons or frame of the back in reversing the seat is avoided; and to that end the invention consists in the peculiar construction, arrangement, and combinations of the various parts, all as more fully hereinafter set forth.

Figures 1 and 2 are side elevations, the former being partly in section. Fig. 3 is a cross-section on the line $x x$, Fig. 1.

In the accompanying drawings, which form a part of this specification, A represents the leg-frame of a car-seat, and B the back-iron. Ordinarily the back-iron is pivotally secured or hung upon an inwardly-projecting stud beneath the arm-rest of the frame A and arranged to lie within one of two brackets—one upon either side of the frame—so that the seat-back can be turned over to face in either direction; and in this construction locks C, which may be of any well-known construction, but preferably spring-locks, are sometimes employed for retaining the back in its position.

In my construction I removably secure the lower end of the back-iron upon the inner end of a short shaft, D, which is journaled through the frame A, just beneath the arm-rest, the outer end of said shaft carrying a disk, E.

F are two barrels or cups rigidly secured to the frame A beneath the arm-rest, and in each of these cups is placed a coil-spring, G, the inner ends of which find resistance against the heads of the cups. As these cups are all constructed alike, I have shown the springs in one only, which I deem sufficient. Through these springs and the heads of the cups I pass a tension-rod, H, the outer ends of which receive a nut, I. The inner or projecting ends

of the rods are connected by means of the pitmen J to the disk E.

In practice, when the seat-back is half-way reversed, as in Fig. 1, the pivotal connections between the disk E and the rods H are upon or nearly upon the same horizontal plane, and all the compression upon the springs within the barrels is removed or at a minimum. As the back is now pushed in either direction, it has to be pushed down against the increasing resistance of both of the springs, and it can readily be seen that the disk E is compelled to partially rotate, drawing or pulling the rods H out of the barrels and compressing the springs. When the back has been pushed down so as to abut against the rests, it is locked in position by means of a suitable lock, a spring-lock, such as C, being preferably employed to retain it in this position. When it is desired to reverse the seat, the back is first unlocked, when the tension of the springs causes the back to partially rise and prevents its accidentally falling back or from falling suddenly in the opposite direction after it has passed the center, thereby avoiding all danger and liability of breaking the back-irons or of separating them from the ends of the back-frames, as often occurs.

What I claim as my invention is—

1. In a reversible seat, the combination, with the frame A and the back having arm B pivoted to said frame, of a tension device permanently connected with said arm and constructed to act as a brake in reversing the seat, substantially as shown and described.

2. The combination, with the frame A and the pivoted seat-back having a fixed hinge-pin, of a spring-actuated tension device arranged to operate on said hinge-pin and act as a brake in reversing the seat-back, substantially as described.

3. In a reversible seat, the combination, with the frame A and pivoted seat-back having fixed hinge-pin and the arm-rail, of tension-rods secured under the overhanging part of the arm-rail and having crank-connections with the fixed hinge-pin of the seat-back, substantially as and for the purpose specified.

4. In a reversible seat, the combination of a pivoted seat-back having a fixed hinge-pin, two spring-barrels secured upon the opposite

sides of the hinge-pin, and crank-connections between the hinge-pin and spring-barrels, all arranged to operate as described.

5 In a reversible car-seat, the combination, with the arm-rail and the pivoted seat-back, of a hinge-pin secured to the pintle of the hinge of the seat-back, and two cranks upon opposite sides of said hinge-pin, and elastic connections between said crank and arm-rails, all arranged and operating substantially in the manner and for the purpose described.

10 6. In a reversible car-seat back, the combination, with the seat-frame, of a back-iron journaled to the seat-frame and carrying a hinge-pin, spring-barrels upon opposite sides of the

hinge-pin, and a disk on the outer end of said hinge-pin and pivotally connected to the tension-rods of said spring-barrels, substantially as and for the purposes set forth.

7. In a reversible car-seat back, the combination of the seat-frame A, shaft H, journaled to the frame, and back-hanger B, secured upon shaft H, said shaft H carrying upon its outer end a disk or double crank, E, connected by suitable connections to tension devices upon opposite sides, substantially as described.

OSCAR R. LEHNDORFF.

Witnesses:

E. J. SCULLY,
H. S. SPRAGUE.