



(19) **United States**

(12) **Patent Application Publication**

Galloway et al.

(10) **Pub. No.: US 2002/0028715 A1**

(43) **Pub. Date: Mar. 7, 2002**

(54) **GOLF CLUB HEAD WITH A FACE COMPOSED OF A FORGED MATERIAL**

Publication Classification

(51) **Int. Cl.⁷ A63B 53/04**

(52) **U.S. Cl. 473/342**

(75) Inventors: **J. Andrew Galloway**, Escondido, CA (US); **Richard C. Helmstetter**, Rancho Santa Fe, CA (US); **Alan Hocknell**, Encinitas, CA (US); **Ronald C. Boyce**, Cardiff, CA (US); **Homer E. Aguinaldo**, San Diego, CA (US); **Curtis S. Woolley**, Carlsbad, CA (US)

(57) **ABSTRACT**

A golf club having a club head with a striking plate having a thickness in the range of 0.010 to 0.250 inch is disclosed herein. The club head may be composed of three pieces, a face, a sole and a crown. Each of the pieces may be composed of a titanium material. The striking plate of the club head may have an aspect ratio less than 1.7. The striking plate may also have concentric regions of thickness with the thickness portion in the center. The club head may be composed of a titanium material, have a volume in the range of 175 cubic centimeters to 400 cubic centimeters, a weight in the range of 165 grams to 300 grams, and a striking plate surface area in the range of 4.00 square inches to 7.50 square inches. The golf club head may also have a coefficient of restitution greater than 0.8 under test conditions such as the USGA test conditions specified pursuant to Rule 4-1e, Appendix II, of the Rules of Golf for 1998-1999.

Correspondence Address:
CALLAWAY GOLF COMPANY
2285 RUTHERFORD ROAD
CARLSBAD, CA 92008

(73) Assignee: **Callaway Golf Company**, Carlsbad, CA

(21) Appl. No.: **09/683,118**

(22) Filed: **Nov. 20, 2001**

Related U.S. Application Data

(63) Continuation of application No. 09/431,982, filed on Nov. 1, 1999.

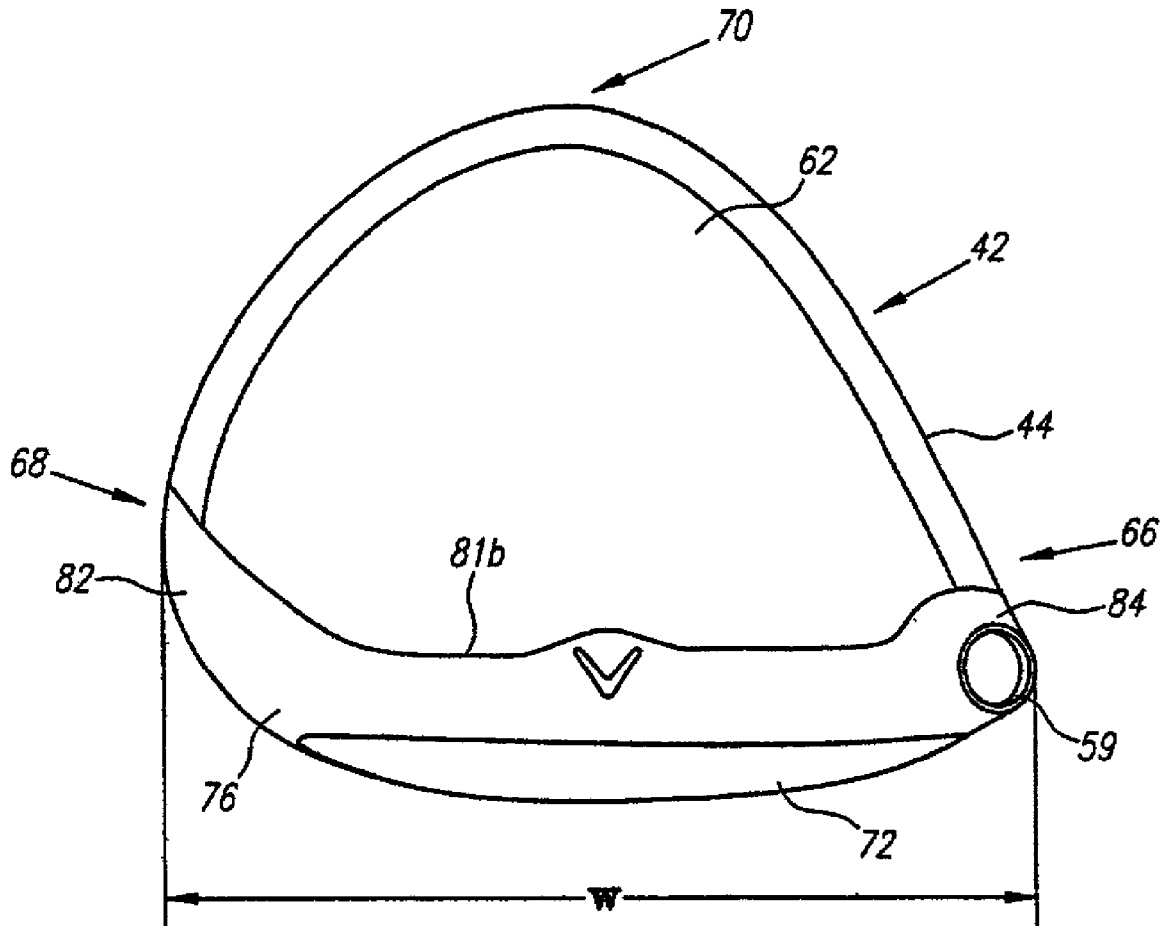

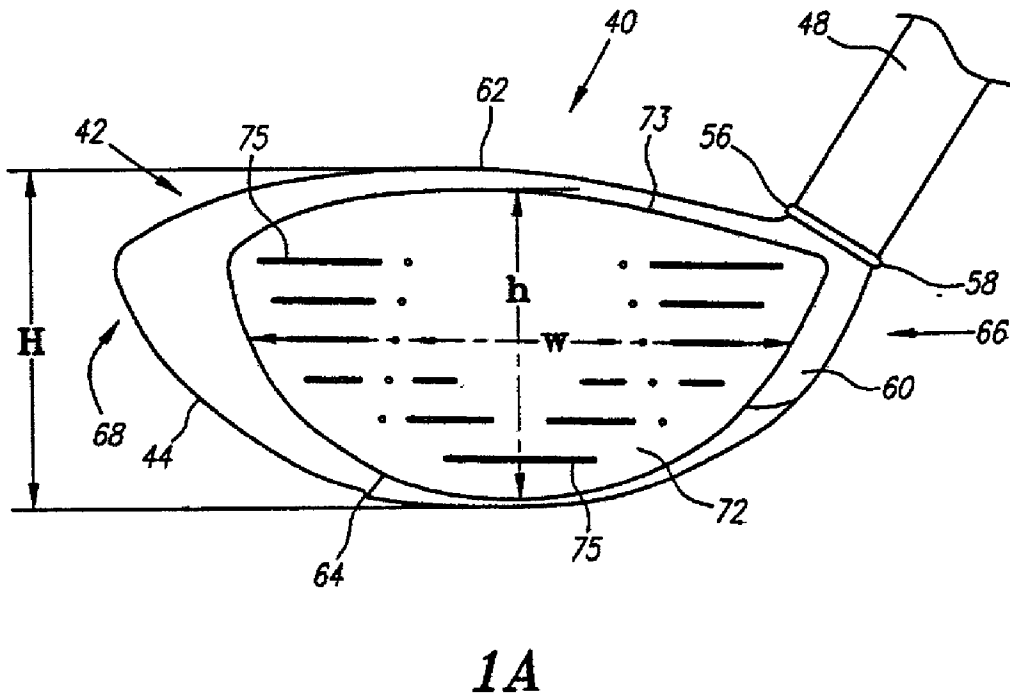
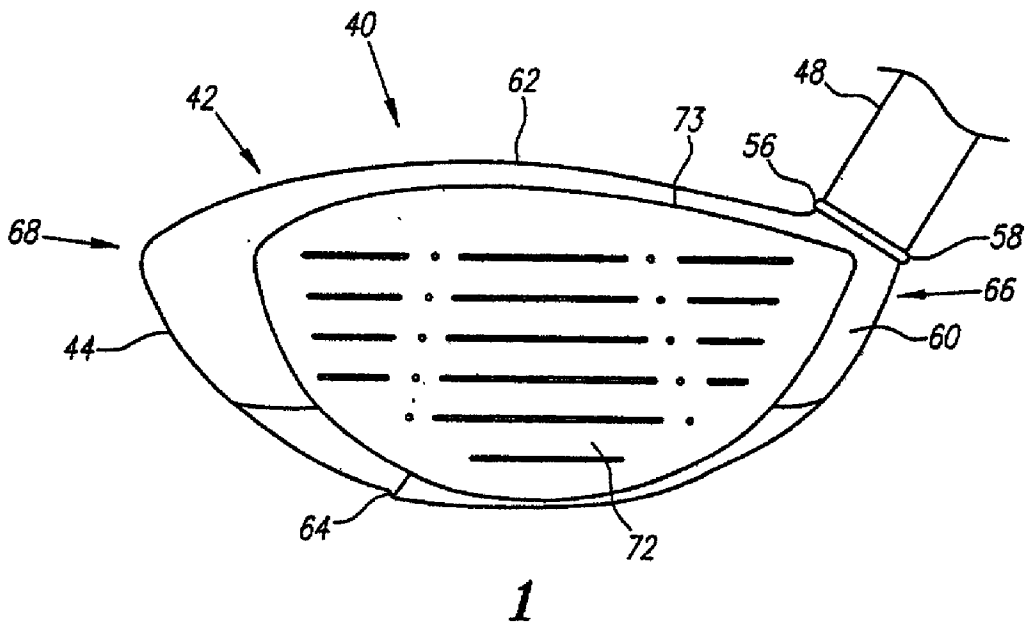

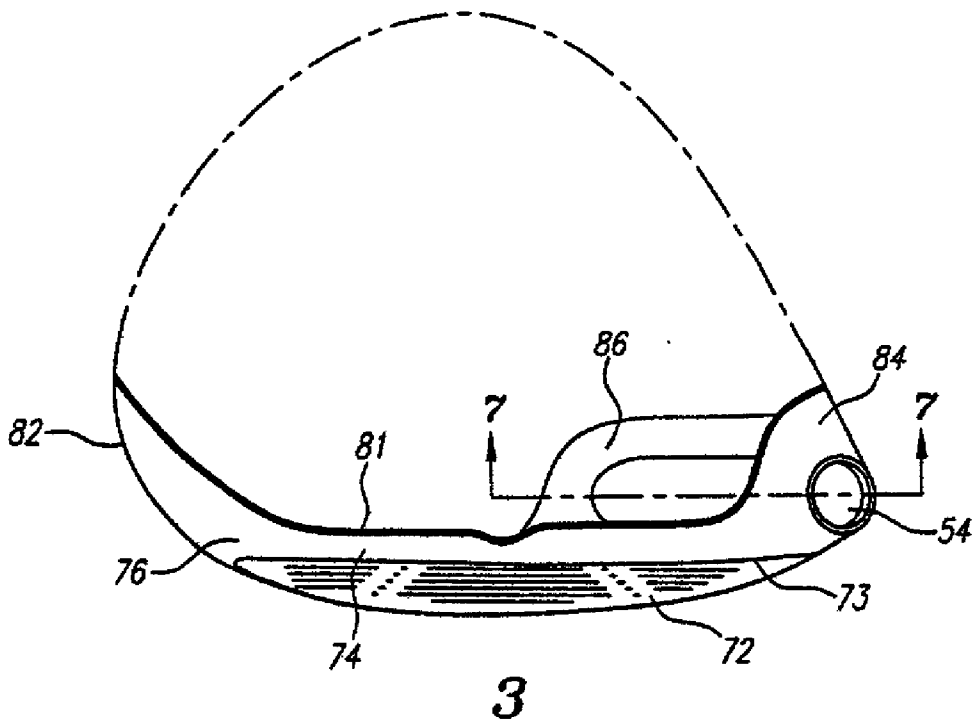
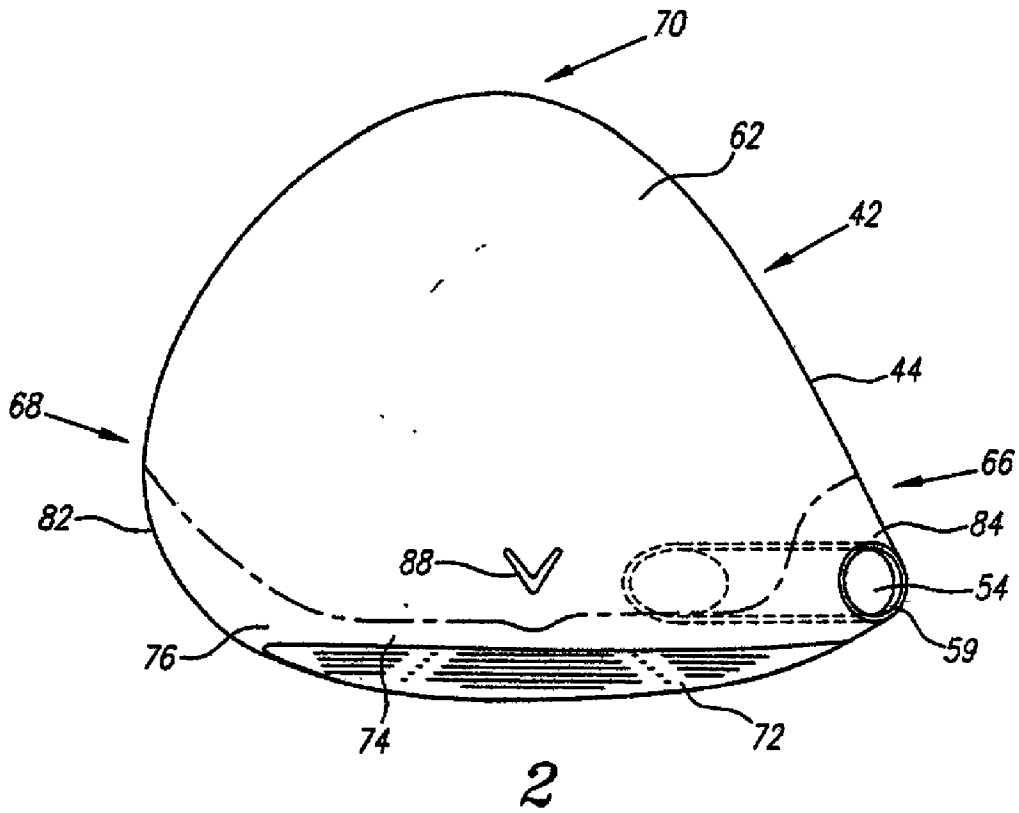

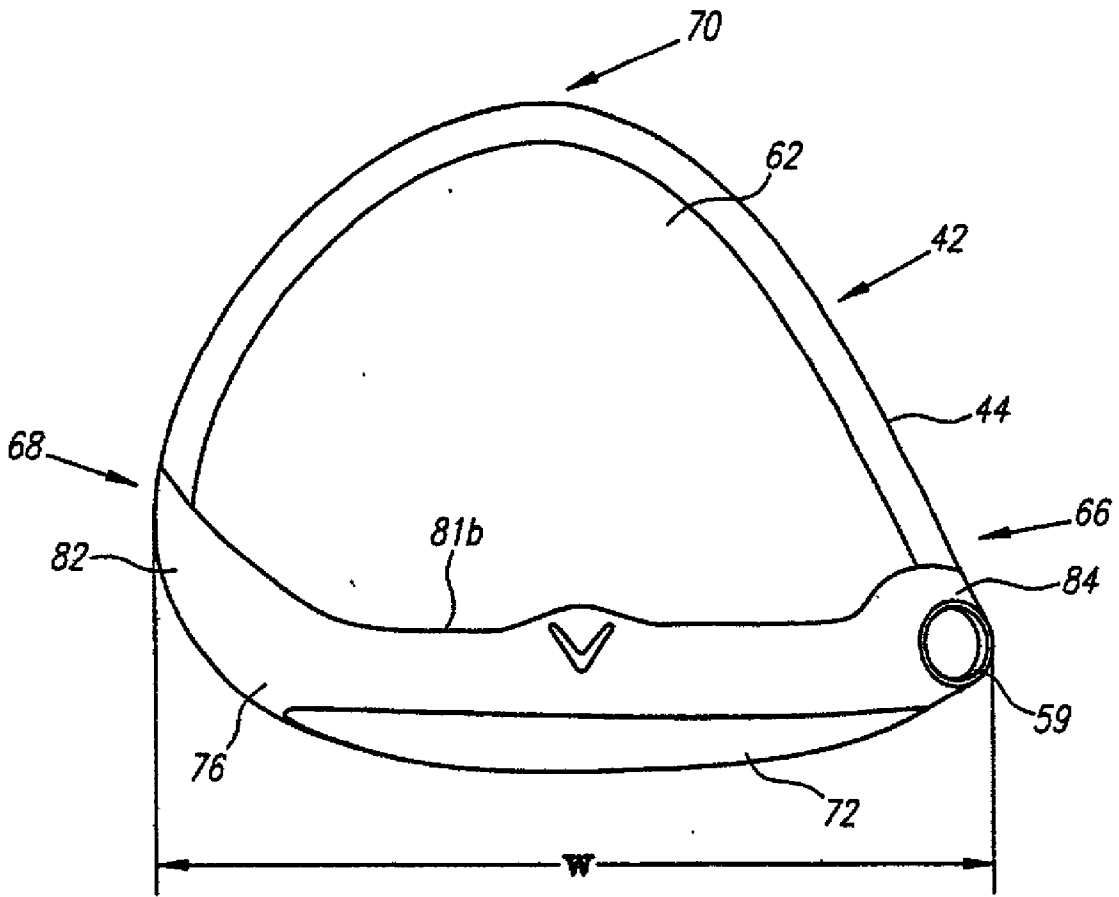

2A

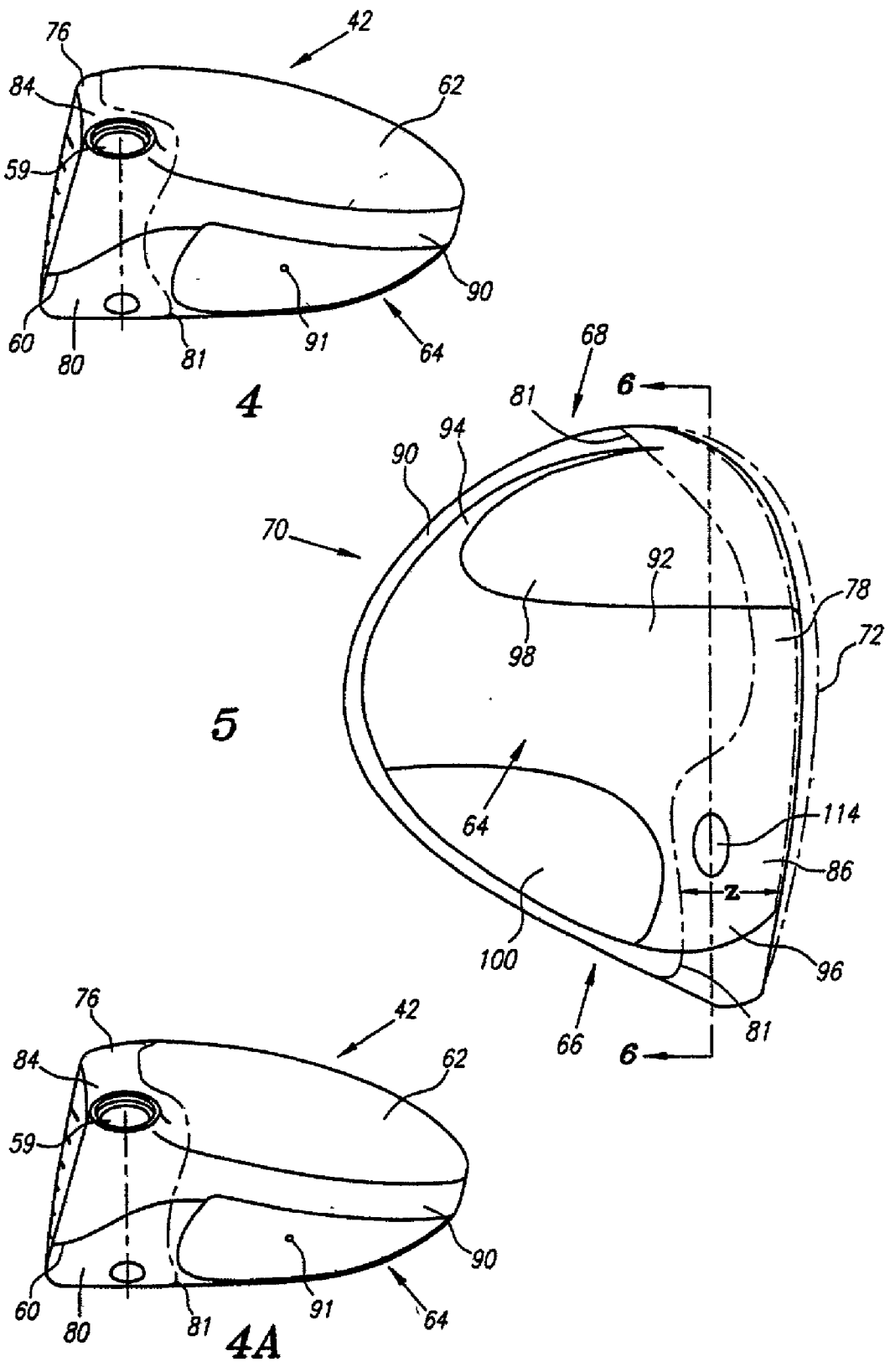

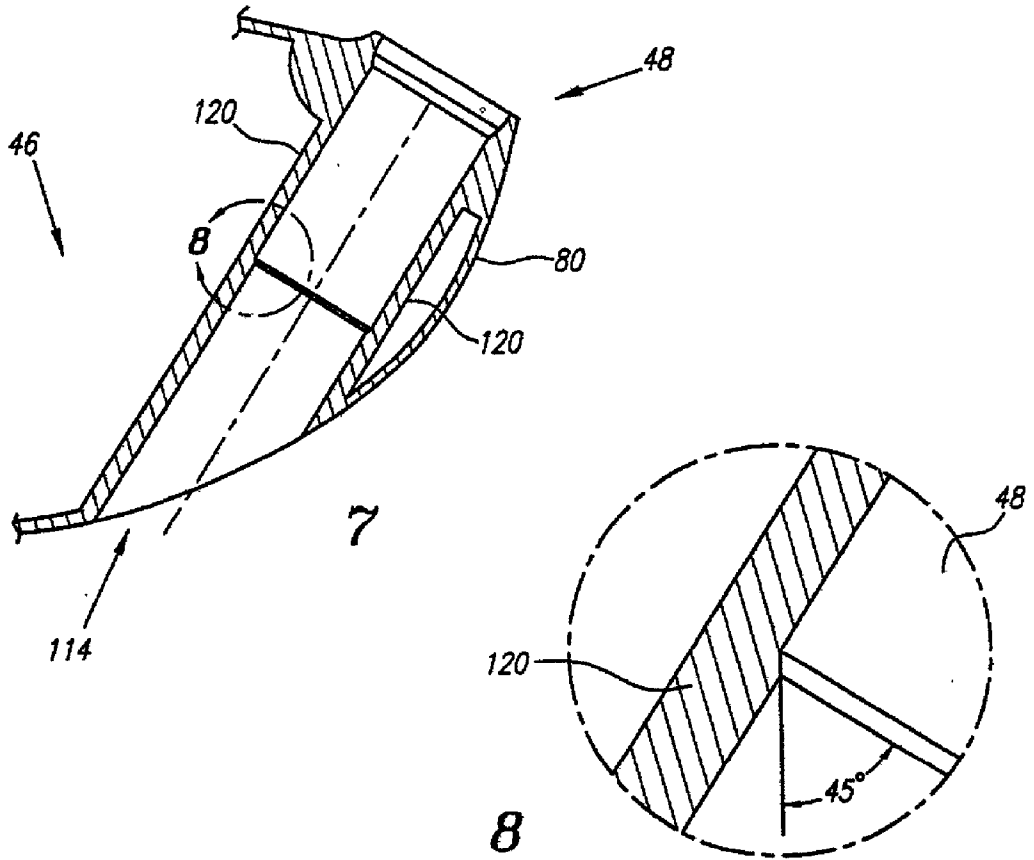
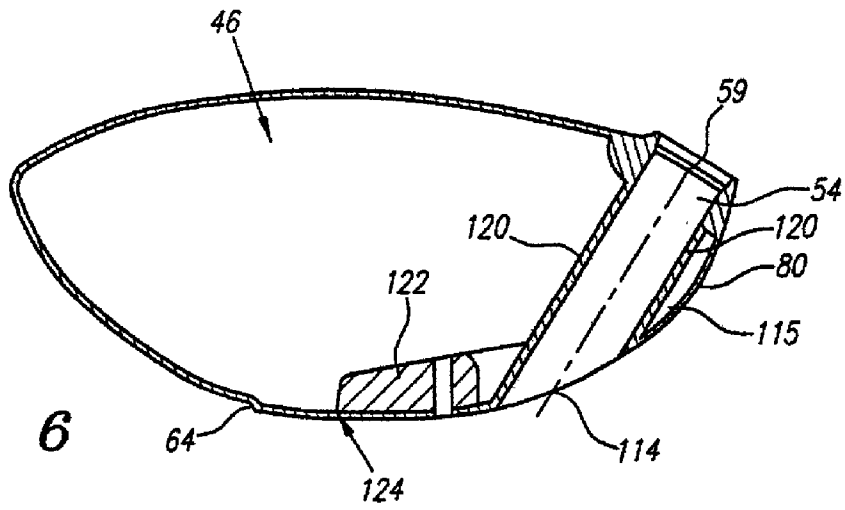

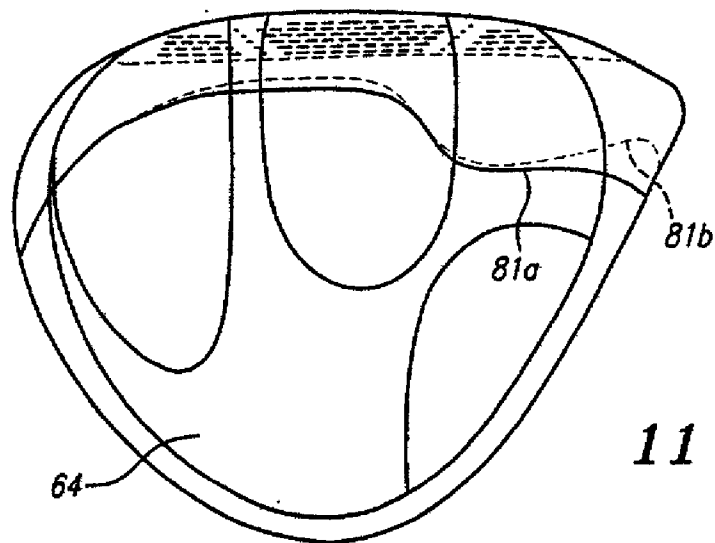
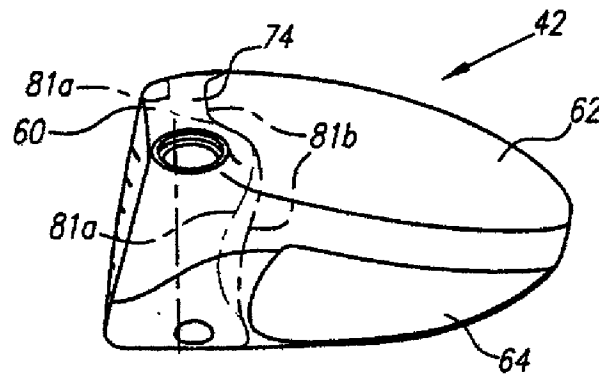
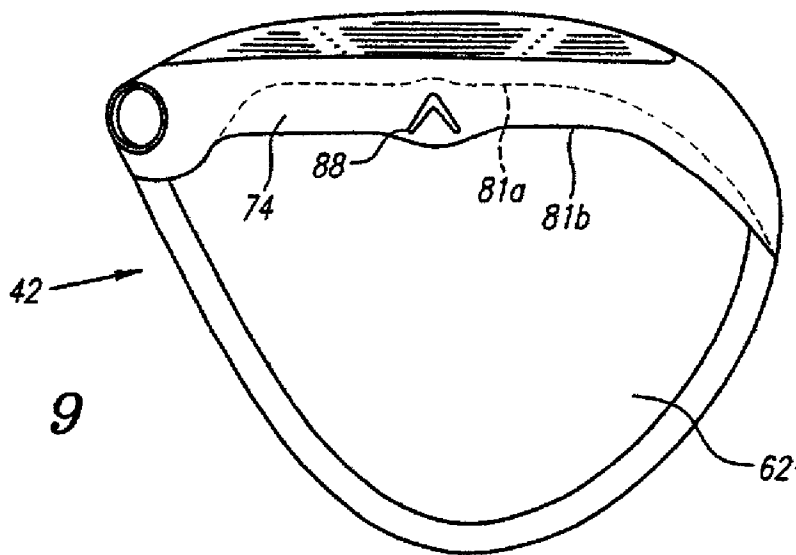

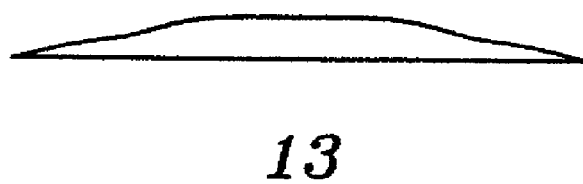
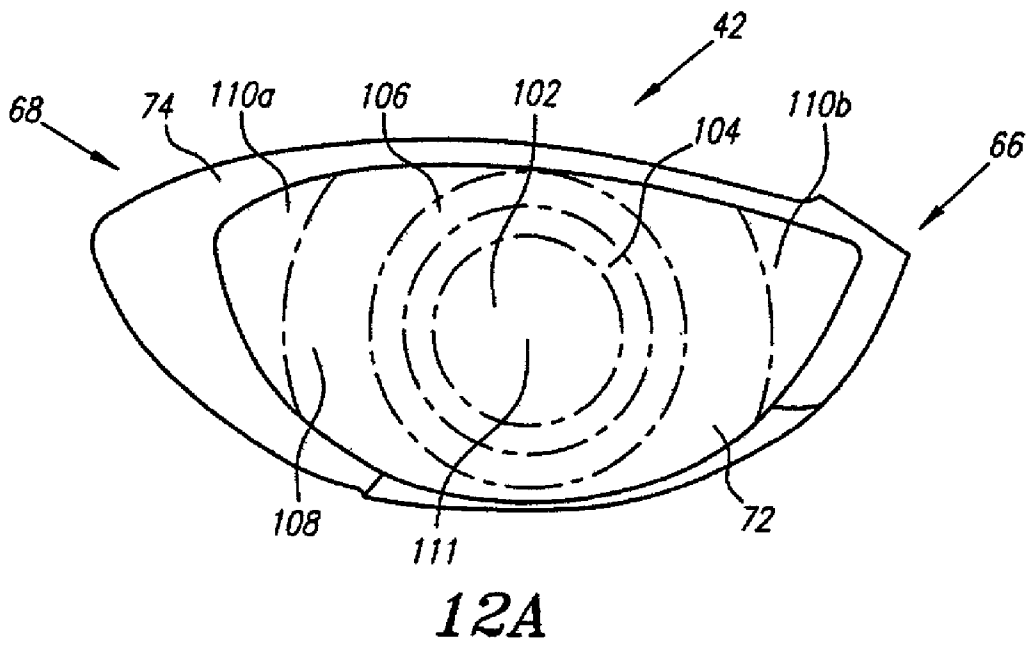
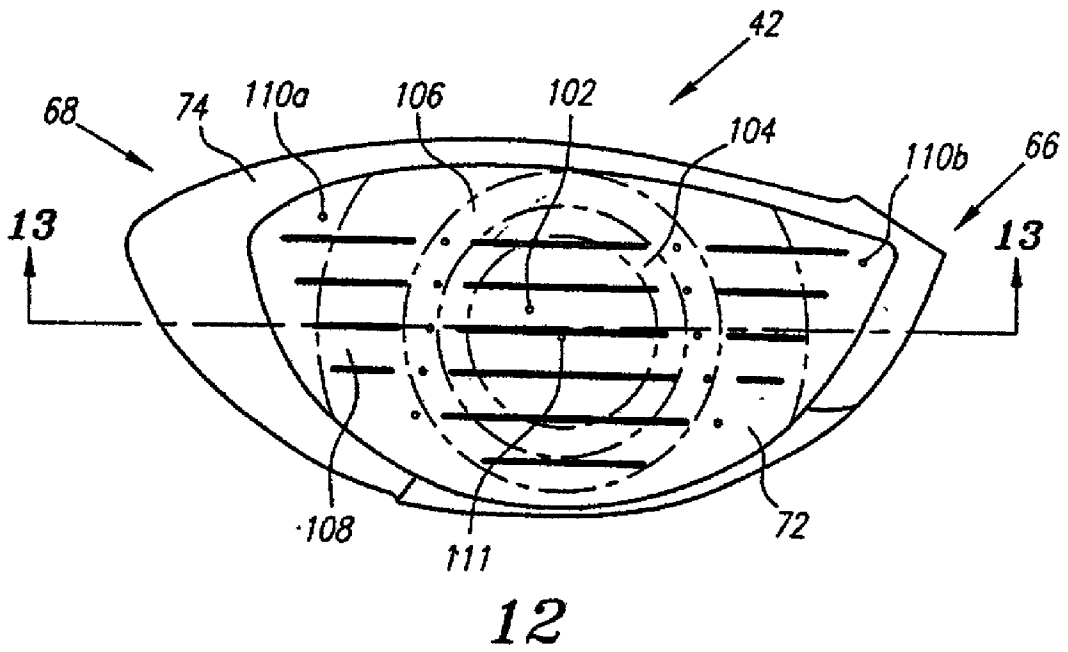

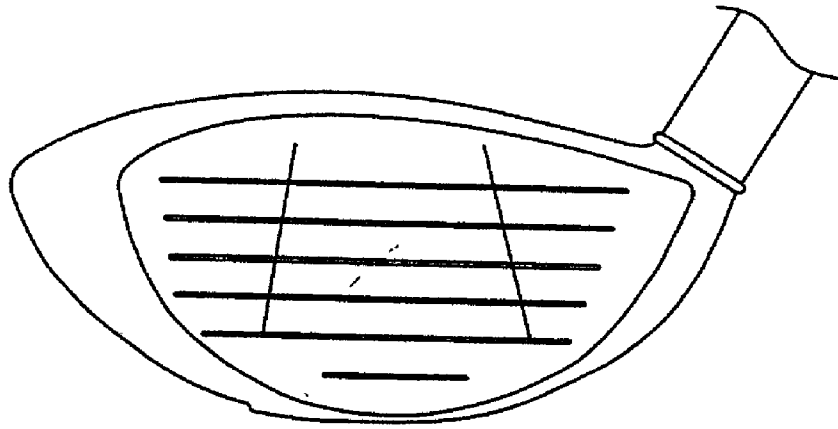

14

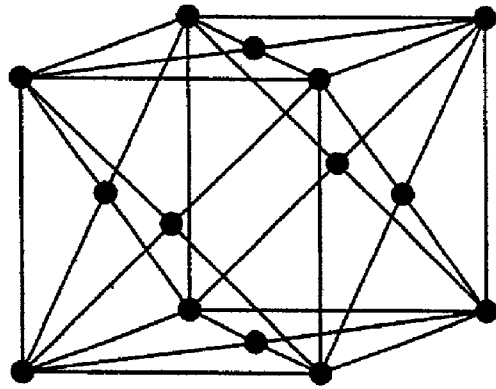

15

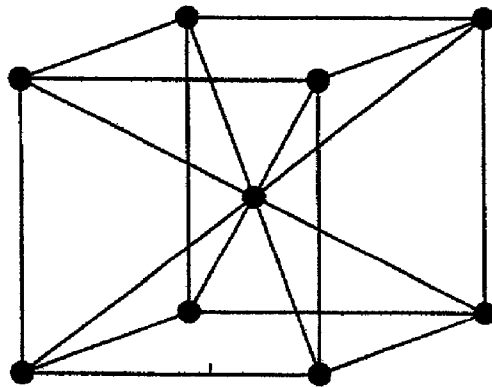

16

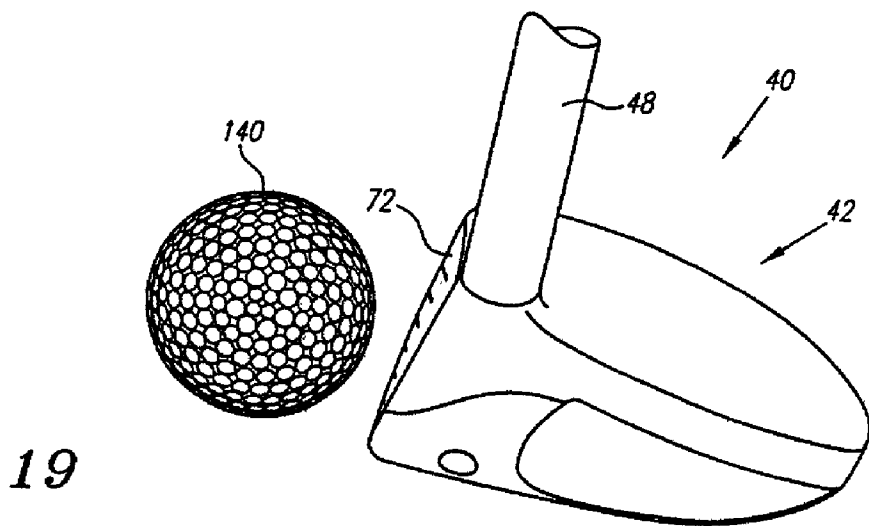
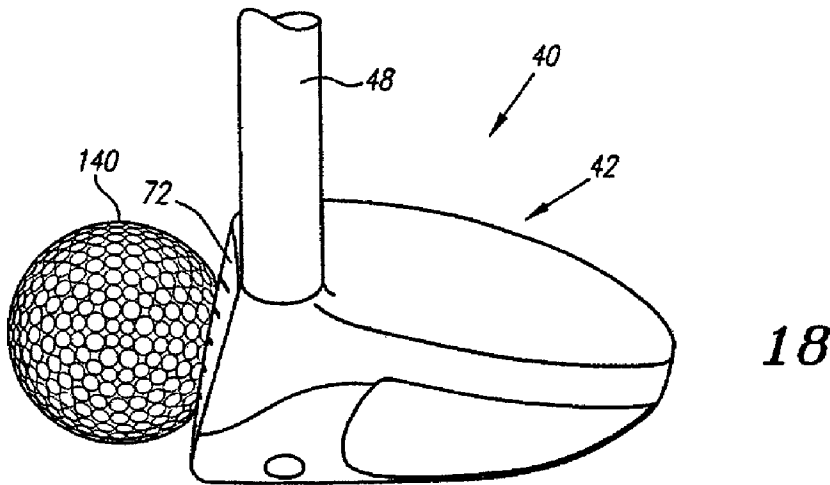
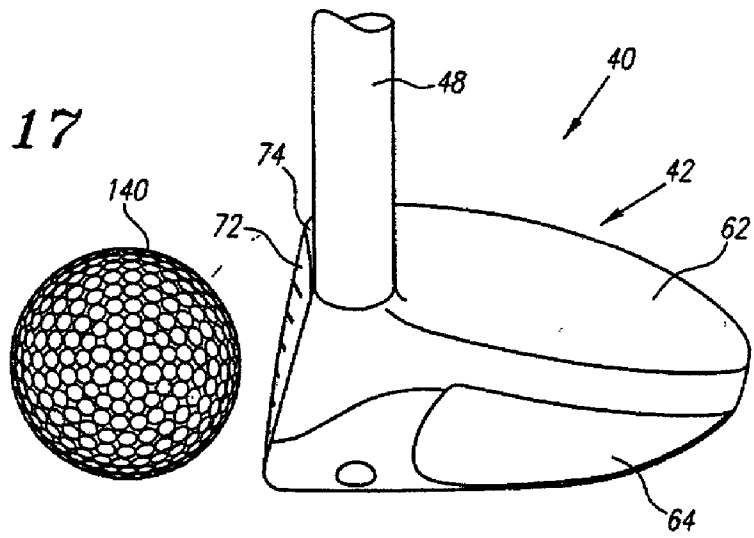

GBB von Mises stresses vs Area (100mph head speed, Precept EV ball)

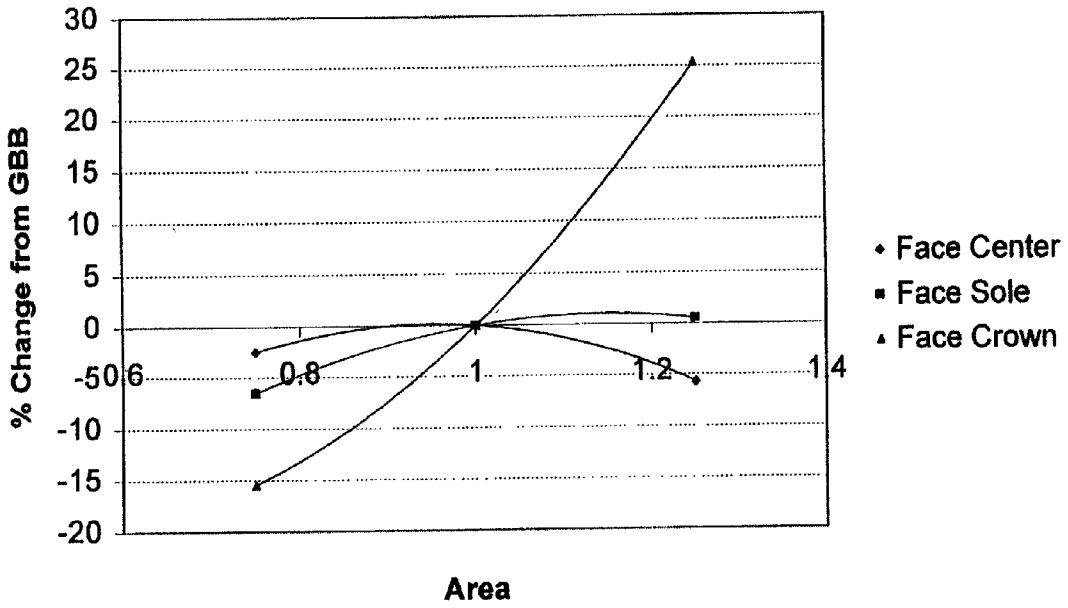

GBB COR and Face Deflection vs Area (100mph head speed, Precept EV ball)

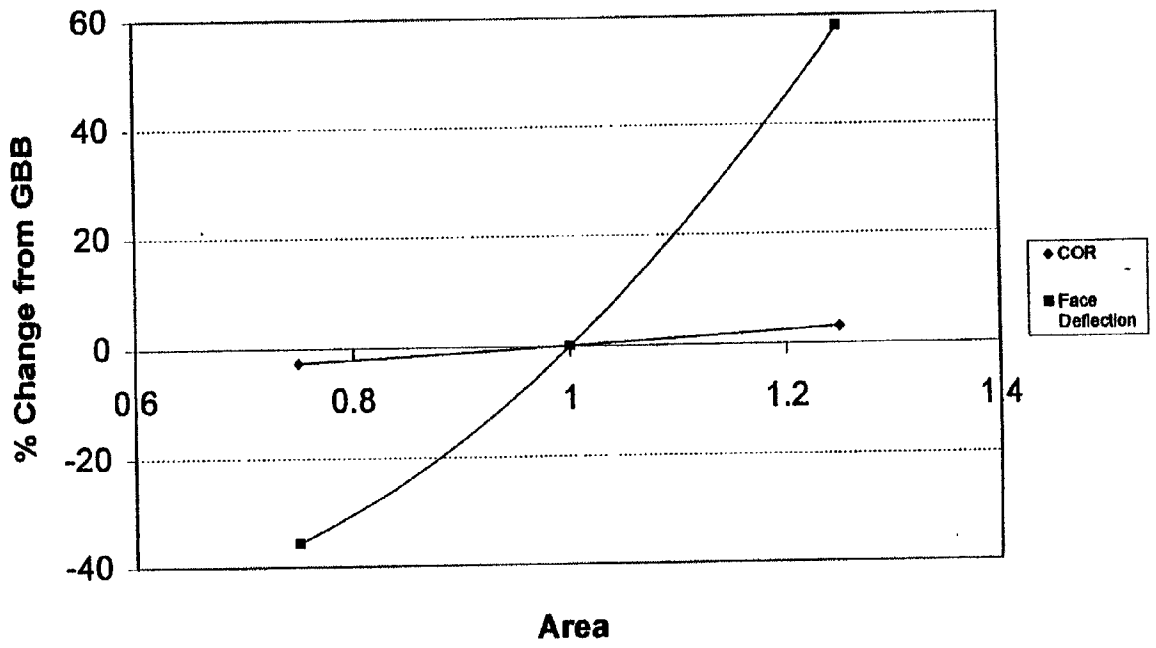

GBB von Mises stresses vs Aspect ratio (100mph head speed, Precept EV ball)

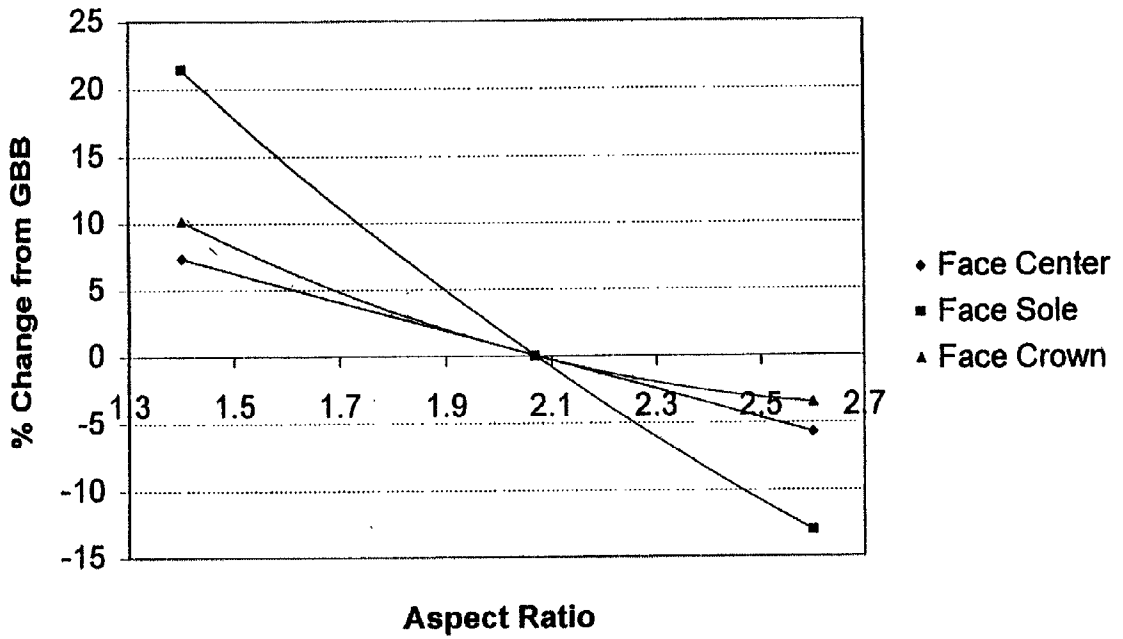

GBB COR and Face Deflection vs Aspect ratio (100mph head speed, Precept EV ball)

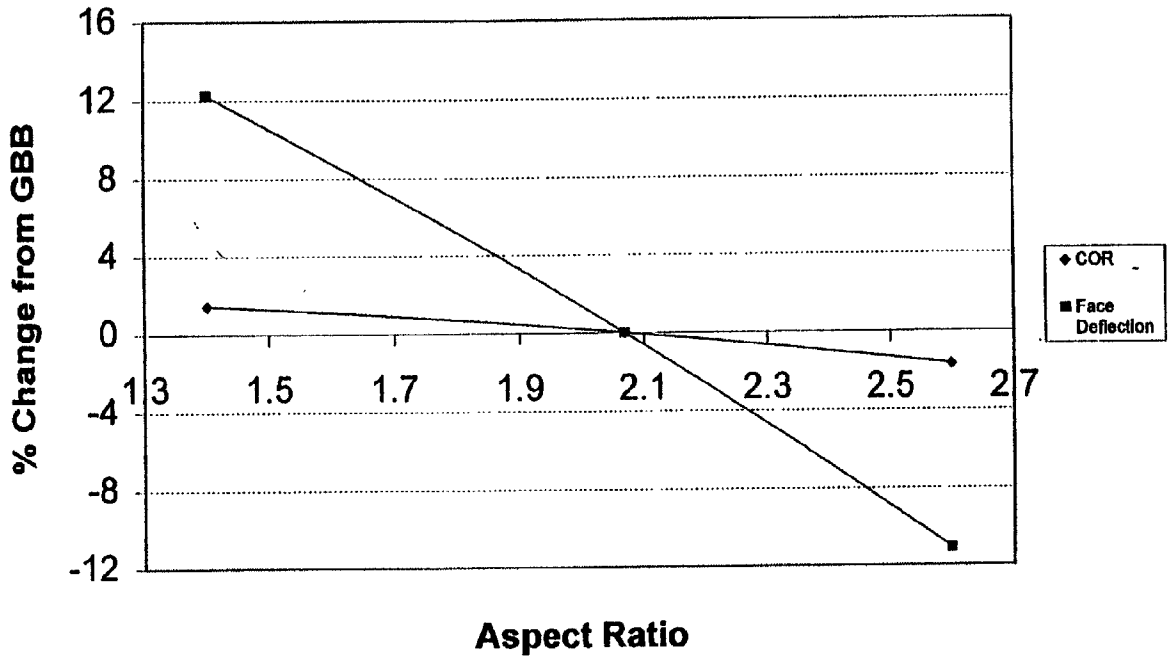

GBB von Mises stresses vs Thickness ratio (100mph head speed, Precept EV ball)

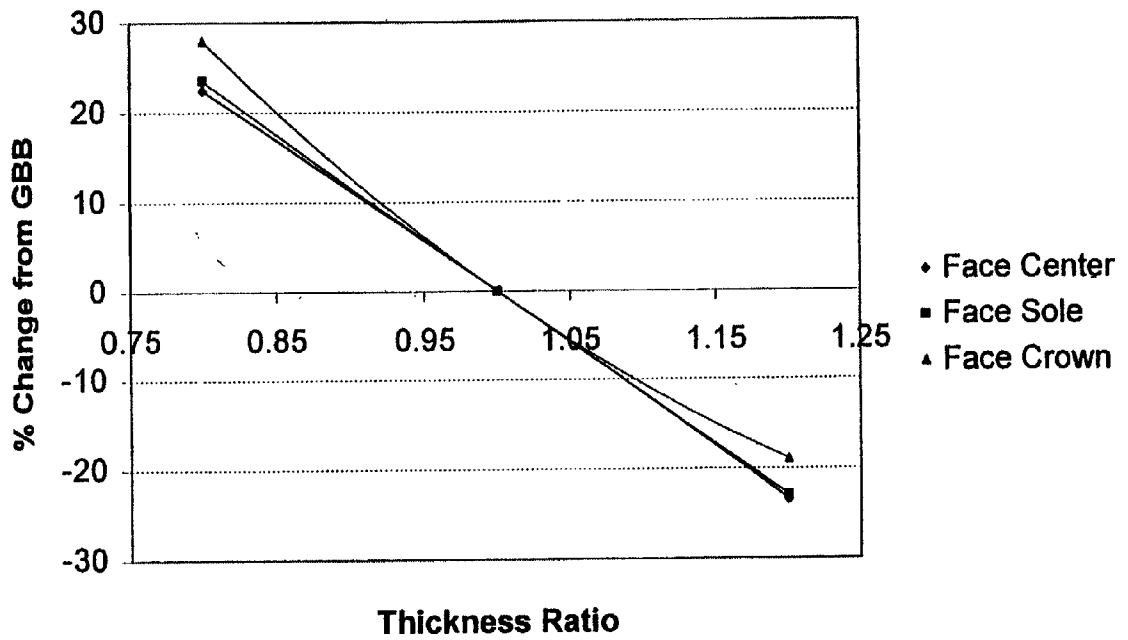

GBB COR and Face Deflection vs Thickness ratio (100mph head speed, Precept EV ball)

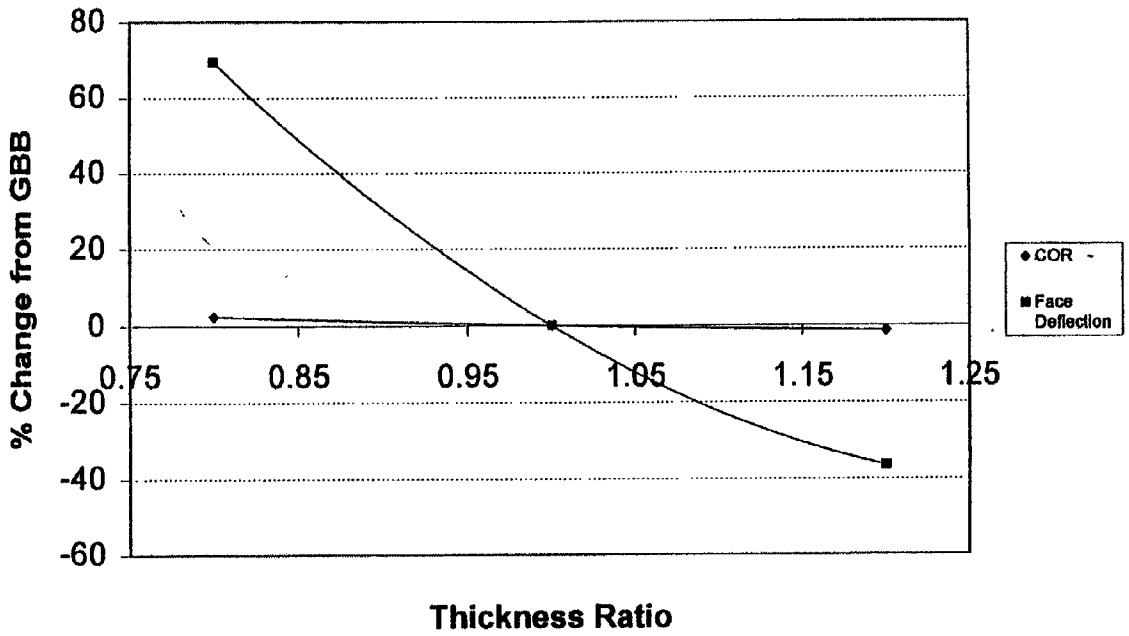

GBB COR vs Face Deflection (100mph head speed, Precept EV ball)

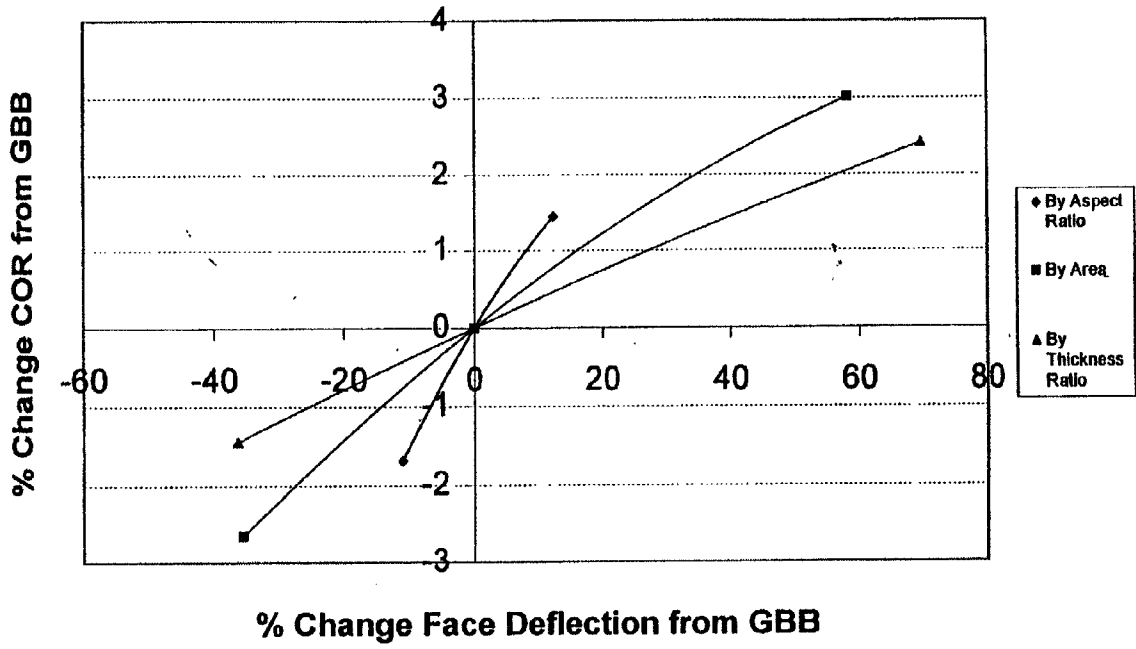

GBB COR vs Face Crown von Mises Stress (100mph head speed, Precept EV ball)

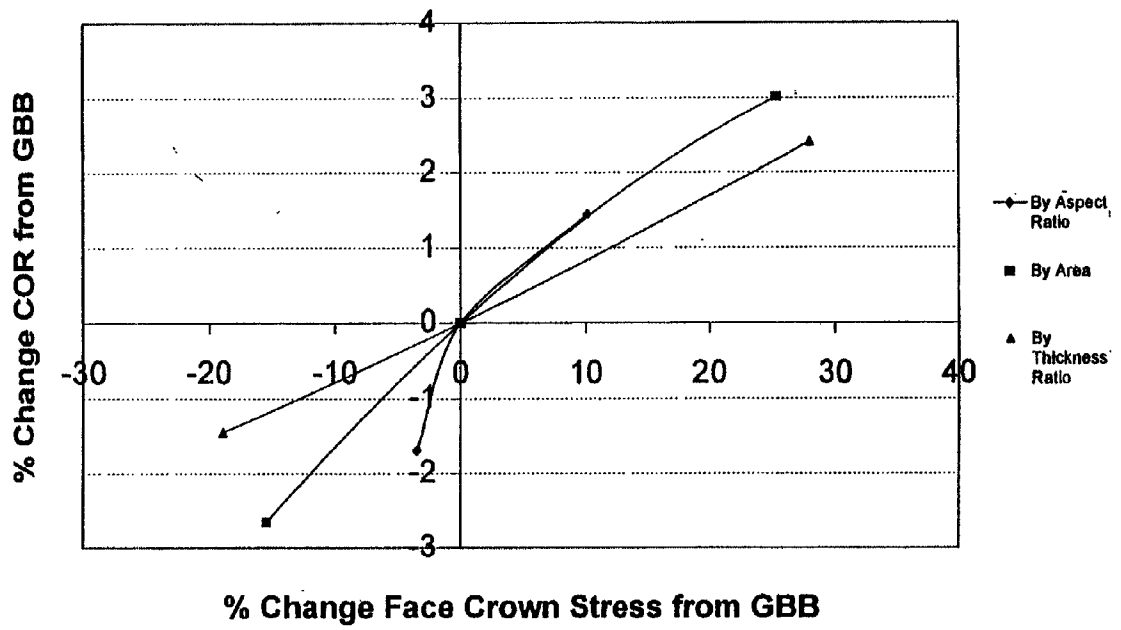

GBB COR vs Face Center von Mises Stress (100mph head speed, Precept EV ball)

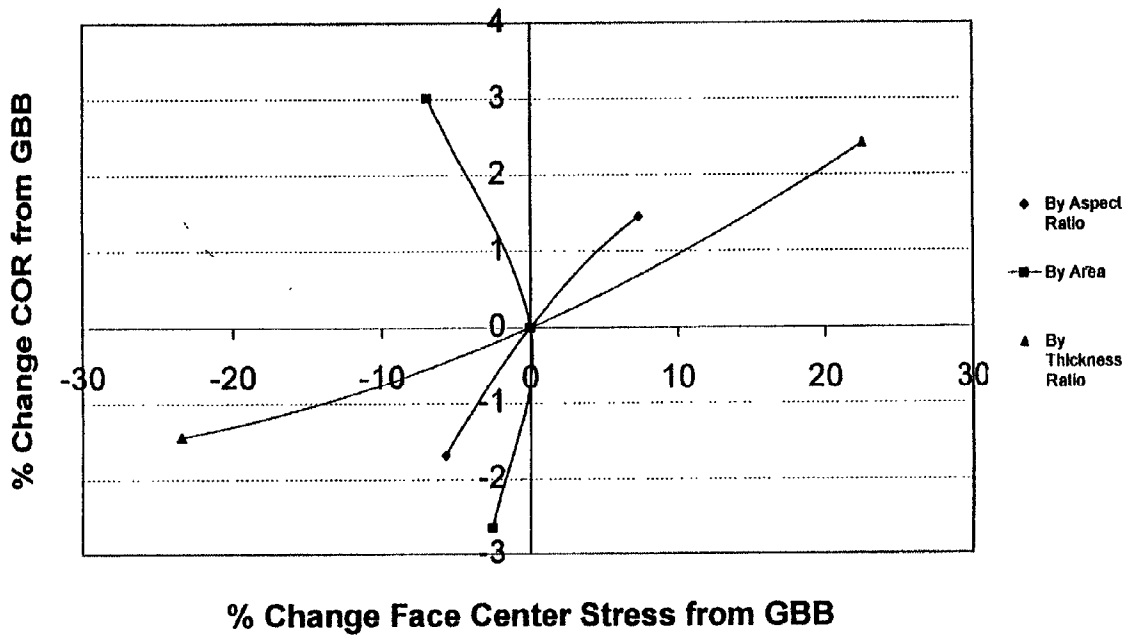

GBB COR vs Face Sole von Mises Stress (100mph head speed, Precept EV ball)

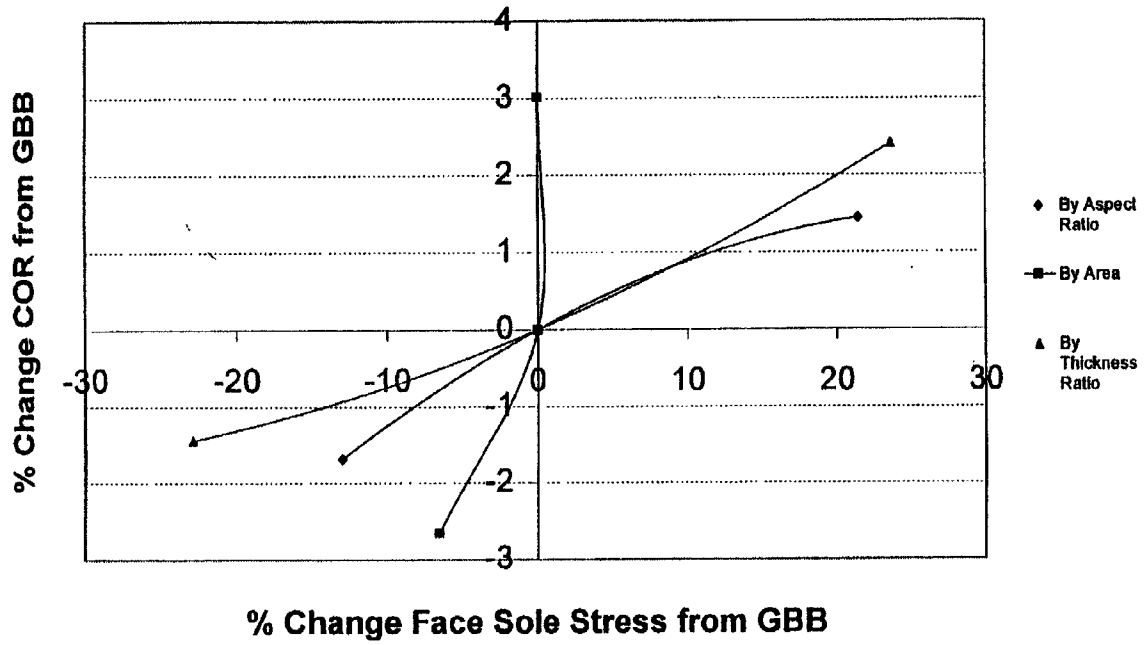

GOLF CLUB HEAD WITH A FACE COMPOSED OF A FORGED MATERIAL

CROSS REFERENCE TO RELATED APPLICATIONS

[0001] This application is a continuation application of co-pending U.S. Patent Application Ser. No. 09/431,982 filed on Nov. 1, 1999.

FEDERAL RESEARCH STATEMENT

[0002] [Not Applicable]

BACKGROUND OF INVENTION

[0003] 1. Field of the Invention

[0004] The present invention relates to a golf club head with a face composed of a forged material. More specifically, the present invention relates to a golf club head with face composed of a thin forged material for a more efficient transfer energy to a golf ball at impact.

[0005] 2. Description of the Related Art

[0006] When a golf club head strikes a golf ball, large impacts are produced that load the club head face and the golf ball. Most of the energy is transferred from the head to the golf ball, however, some energy is lost as a result of the collision. The golf ball is typically composed of polymer cover materials (such as ionomers) surrounding a rubber-like core. These softer polymer materials having damping (loss) properties that are strain and strain rate dependent which are on the order of 10-100 times larger than the damping properties of a metallic club face. Thus, during impact most of the energy is lost as a result of the high stresses and deformations of the golf ball (0.001 to 0.20 inch), as opposed to the small deformations of the metallic club face (0.025 to 0.050 inch). A more efficient energy transfer from the club head to the golf ball could lead to greater flight distances of the golf ball.

[0007] The generally accepted approach has been to increase the stiffness of the club head face to reduce metal or club head deformations. However, this leads to greater deformations in the golf ball, and thus increases in the energy transfer problem.

[0008] Some have recognized the problem and disclosed possible solutions. An example is Campau, U.S. Pat. No. 4,398,965, for a Method Of Making Iron Golf Clubs With Flexible Impact Surface, which discloses a club having a flexible and resilient face plate with a slot to allow for the flexing of the face plate. The face plate of Campau is composed of a ferrous material, such as stainless steel, and has a thickness in the range of 0.1 inch to 0.125 inch.

[0009] Another example is Eggiman, U.S. Pat. No. 5,863,261, for a Golf Club Head With Elastically Deforming Face And Back Plates, which discloses the use of a plurality of plates that act in concert to create a spring-like effect on a golf ball during impact. A fluid is disposed between at least two of the plates to act as a viscous coupler.

[0010] Yet another example is Jepson et al, U.S. Pat. No. 3,937,474, for a golf Club With A Polyurethane Insert. Jepson discloses that the polyurethane insert has a hardness between 40 and 75 shore D.

[0011] Still another example is Inamori, U.S. Pat. No. 3,975,023, for a Golf Club Head With Ceramic Face Plate, which discloses using a face plate composed of a ceramic material having a high energy transfer coefficient, although ceramics are usually harder materials. Chen et al., U.S. Pat. No. 5,743,813 for a Golf Club Head, discloses using multiple layers in the face to absorb the shock of the golf ball. One of the materials is a non-metal material.

[0012] Lu, U.S. Pat. No. 5,499,814, for a Hollow Club Head With Deflecting Insert Face Plate, discloses a reinforcing element composed of a plastic or aluminum alloy that allows for minor deflecting of the face plate which has a thickness ranging from 0.01 to 0.30 inch for a variety of materials including stainless steel, titanium, KEVLAR®, and the like. Yet another Campau invention, U.S. Pat. No. 3,989,248, for a Golf Club Having Insert Capable Of Elastic Flexing, discloses a wood club composed of wood with a metal insert.

[0013] Although not intended for flexing of the face plate, Viste, U.S. Pat. No. 5,282,624 discloses a golf club head having a face plate composed of a forged stainless steel material and having a thickness of 3 mm. Anderson, U.S. Pat. No. 5,344,140, for a Golf Club Head And Method Of Forming Same, also discloses use of a forged material for the face plate. The face plate of Anderson may be composed of several forged materials including steel, copper and titanium. The forged plate has a uniform thickness of between 0.090 and 0.130 inch.

[0014] Another invention directed toward forged materials in a club head is Su et al., U.S. Pat. No. 5,776,011 for a Golf Club Head. Su discloses a club head composed of three pieces with each piece composed of a forged material. The main objective of Su is to produce a club head with greater loft angle accuracy and reduce structural weaknesses. Finally, Aizawa, U.S. Pat. No. 5,346,216 for a Golf Club Head, discloses a face plate having a curved ball hitting surface.

[0015] The Rules of Golf, established and interpreted by the United States Golf Association (USGA) and The Royal and Ancient Golf Club of Saint Andrews, set forth certain requirements for a golf club head. The requirements for a golf club head are found in Rule 4 and Appendix II. A complete description of the Rules of Golf are available on the USGA web page at www.usga.org. Although the Rules of Golf do not expressly state specific parameters for a golf club face, Rule 4-1e prohibits the face from having the effect at impact of a spring with a golf ball. In 1998, the USGA adopted a test procedure pursuant to Rule 4-1e which measures club face COR. This USGA test procedure, as well as procedures like it, may be used to measure club face COR.

[0016] Although the prior art has disclosed many variations of face plates, the prior art has failed to provide a face plate with a high coefficient of restitution composed of a thin material.

SUMMARY OF INVENTION

[0017] The present invention provides a golf club head with a striking plate having a high coefficient of restitution in order to increase the post-impact velocity of a golf ball for a given pre-impact club head velocity. The present invention

is able to accomplish this by using a striking plate composed of a thin material, having a small aspect ratio (near 1.0) and having a large surface area.

[0018] One aspect of the present invention is a golf club head having a striking plate having a thickness in the range of 0.010 inch to 0.250 inch, and having a coefficient of restitution of at least 0.83 under test conditions, such as those specified by the USGA. The standard USGA conditions for measuring the coefficient of restitution is set forth in the *USCA Procedure for Measuring the Velocity Ratio of a Club Head for Conformance to Rule 4-7e, Appendix II, Revision I, Aug. 4, 1998* and *Revision 0, Jul. 6, 1998*, available from the USGA.

[0019] Another aspect of the present invention is a golf club head including a face member, a crown and a sole. The face member is composed of a material selected from titanium, titanium alloys, steels, vitreous metals, composites and ceramics. The face member includes a striking plate for striking a golf ball, a face extension and an interior tubing. The face extension extends laterally inward from a perimeter of the striking plate. The interior tubing receives a shaft and engages an upper portion of the face extension and a lower portion of the face extension. The crown is secured to the upper portion of the face extension at a varying distance from the striking plate. The sole plate is secured to the lower portion of the face extension at a varying distance from the striking plate.

[0020] Yet another aspect of the present invention is a golf club head having a striking plate with an aspect ratio no greater than 1.7. The aspect ratio is the ratio of width of the face to the height of the face. Normally, the aspect ratios of club head faces are relatively greater than 1.7. For example, the aspect ratio of the original GREAT BIG BERTHA® driver from Callaway Golf Company of Carlsbad, Calif. was 1.9. As described in greater detail below, the smaller aspect ratio of the striking plate of the club head of the present invention allows for greater compliance and thus a larger coefficient of restitution.

[0021] Yet another aspect of the present invention is a golf club head including a body composed of a titanium material and having a volume in the range of 175 cubic centimeters to 400 cubic centimeters, and preferably 260 cubic centimeters to 350 cubic centimeters, and most preferably in the range of 300 cubic centimeters to 310 cubic centimeters, a weight in the range of 160 grams to 300 grams, preferably 175 grams to 225 grams, and a face having a surface area in the range of 4.50 square inches to 5.50 square inches, and preferably in the range of 4.00 square inches to 7.50 square inches.

[0022] Having briefly described the present invention, the above and further objects, features and advantages thereof will be recognized by those skilled in the pertinent art from the following detailed description of the invention when taken in conjunction with the accompanying drawings.

BRIEF DESCRIPTION OF DRAWINGS

[0023] FIG. 1 is a front view of the golf club of the present invention.

[0024] FIG. 1A is a front view of an alternative embodiment of the golf club of the present invention.

[0025] FIG. 2 is a top plan view of golf club head of FIG. 1.

[0026] FIG. 2A is a top plan view of an alternative embodiment of the golf club of the present invention.

[0027] FIG. 3 is a top plan isolated view of the face member of the golf club head of the present invention with the crown in phantom lines.

[0028] FIG. 4 is a side plan view of the golf club head of the present invention.

[0029] FIG. 4A is a side plan view of an alternative embodiment of the golf club head of the present invention.

[0030] FIG. 5 is a bottom view of the golf club head of the present invention.

[0031] FIG. 6 is a cross-sectional view along line 6-6 of FIG. 5.

[0032] FIG. 7 is a cross-sectional view along line 7-7 of FIG. 3 illustrating the hosel of the golf club head present invention.

[0033] FIG. 8 is an enlarged view of circle 8 of FIG. 7.

[0034] FIG. 9 is a top plan view of overlaid embodiments of the face member of the golf club head of the present invention.

[0035] FIG. 10 is a side view of overlaid embodiments of the face member of the golf club head of the present invention.

[0036] FIG. 11 is a bottom plan view of overlaid embodiments of the face member of the golf club head of the present invention.

[0037] FIG. 12 is a front view of the golf club head of the present invention illustrating the variations in thickness of the striking plate.

[0038] FIG. 12A is a front view of an alternative golf club head of the present invention illustrating the variations in thickness of the striking plate.

[0039] FIG. 13 is a cross-sectional view along line 13-13 of FIG. 12 showing face thickness variation.

[0040] FIG. 14 is a front plan view of a BIG BERTHA® WARIBIRD® driver of the prior art.

[0041] FIG. 15 is a perspective view of a face centered cubic model.

[0042] FIG. 16 is a perspective view of a body centered cubic model.

[0043] FIG. 17 is a side view of a golf club head of the present invention immediately prior to impact with a golf ball.

[0044] FIG. 18 is a side view of a golf club head of the present invention during impact with a golf ball.

[0045] FIG. 19 is a side view of a golf club head of the present invention immediately after impact with a golf ball.

[0046] FIG. 20 is a graph of the percentage change in von Mises stresses using a GREAT BIG BERTHA® shaped golf club as a base reference versus Area for the face center, the face sole and the face crown of the golf club head of the present invention.

[0047] FIG. 21 is a graph of the percentage change in COR and Face Deflection using a GREAT BIG BERTHA® shaped golf club as a base reference versus Area.

[0048] FIG. 22 is a graph of the percentage change in von Mises stresses using a GREAT BIG BERTHA® shaped golf club as a base reference versus Aspect ratio for the face center, the face sole and the face crown of the golf club head of the present invention.

[0049] FIG. 23 is a graph of the percentage change in COR and Face Deflection using a GREAT BIG BERTHA® shaped golf club as a base reference versus Aspect ratio.

[0050] FIG. 24 is a graph of the percentage change in von Mises stresses using a GREAT BIG BERTHA® shaped golf club as a base reference versus Thickness ratio for the face center, the face sole and the face crown of the golf club head of the present invention.

[0051] FIG. 25 is a graph of the percentage change in COR and Face Deflection using a GREAT BIG BERTHA® shaped golf club as a base reference versus Thickness ratio.

[0052] FIG. 26 is a graph of the percentage change in COR using a GREAT BIG BERTHA® shaped golf club as a base reference versus the percentage change in Face deflection using a GREAT BIG BERTHA® shaped golf club as a base reference for the aspect ratio, the area and thickness ratio of a golf club of the present invention.

[0053] FIG. 27 is a graph of the percentage change in COR using a GREAT BIG BERTHA® shaped golf club as a base reference versus the percentage change in Face crown von Mises stress using a GREAT BIG BERTHA® shaped golf club as a base reference for the aspect ratio, the area and thickness ratio of a golf club of the present invention.

[0054] FIG. 28 is a graph of the percentage change in COR using a GREAT BIG BERTHA® shaped golf club as a base reference versus the percentage change in Face center von Mises stress using a GREAT BIG BERTHA® shaped golf club as a base reference for the aspect ratio, the area and thickness ratio of a golf club of the present invention.

[0055] FIG. 29 is a graph of the percentage change in COR using a GREAT BIG BERTHA® shaped golf club as a base reference versus the percentage change in Face sole von Mises stress using a GREAT BIG BERTHA® shaped golf club as a base reference for the aspect ratio, the area and thickness ratio of a golf club of the present invention.

DETAILED DESCRIPTION

[0056] The present invention is directed at a golf club head having a striking plate that is thin and has a high coefficient of restitution thereby enabling for greater distance of a golf ball hit with the golf club head of the present invention. The coefficient of restitution (also referred to herein as COR) is determined by the following equation: $e = \frac{v_2 v_1}{U_1 U_2}$ wherein U_1 is the club head velocity prior to impact; U_2 is the golf ball velocity prior to impact which is zero; v_1 is the club head velocity just after separation of the golf ball from the face of the club head; v_2 is the golf ball velocity just after separation of the golf ball from the face of the club head; and e is the coefficient of restitution between the golf ball and the club face.

[0057] The values of e are limited between zero and 1.0 for systems with no energy addition. The coefficient of

restitution, e , for a material such as a soft clay or putty would be near zero, while for a perfectly elastic material, where no energy is lost as a result of deformation, the value of e would be 1.0. The present invention provides a club head having a striking plate or face with a coefficient of restitution approaching 0.93, as measured under conventional test conditions.

[0058] As shown in FIGS. 1-5, a golf club is generally designated 40. The golf club 40 has a golf club head 42 with a body 44 and a hollow interior, not shown. Engaging the club head 42 is a shaft 48 that has a grip 50, not shown, at a butt end 52 and is inserted into a hosel 54 at a tip end 56. An O-ring 58 may encircle the shaft 48 at an aperture 59 to the hosel 54.

[0059] The body 44 of the club head 42 is generally composed of three sections, a face member 60, a crown 62 and a sole 64. The club head 42 may also be partitioned into a heel section 66 nearest the shaft 48, a toe section 68 opposite the heel section 66, and a rear section 70 opposite the face member 60.

[0060] The face member 60 is generally composed of a single piece of metal, and is preferably composed of a forged metal material. More preferably, the forged metal material is a forged titanium material. However, those skilled in the relevant art will recognize that the face member may be composed of other materials such as steels, vitreous metals, ceramics, composites, carbon, carbon fibers and other fibrous materials without departing from the scope and spirit of the present invention. The face member 60 generally includes a face plate (also referred to herein as a striking plate) 72 and a face extension 74 extending laterally inward from the perimeter of the face plate 72. The face plate 72 has a plurality of scorelines 75 thereon. An alternative embodiment of the face plate 72 is illustrated in FIG. 1A which has a different scoreline pattern. A more detailed explanation of the scorelines 75 is set forth in co-pending U.S. patent application Ser. No. 09/431,518, filed on Nov. 1, 1999, entitled Contoured Scorelines For The Face Of A Golf Club, and incorporated by reference in its entirety. The face extension 74 generally includes an upper lateral extension 76, a lower lateral extension 78, a heel wall 80 and a toe wall 82.

[0061] The upper lateral extension 76 extends inward, toward the hollow interior 46, a predetermined distance to engage the crown 62. In a preferred embodiment, the predetermined distance ranges from 0.2 inch to 1.0 inch, as measured from the perimeter 73 of the face plate 72 to the edge of the upper lateral extension 76. Unlike the prior art which has the crown engage the face plate perpendicularly, the present invention has the face member 60 engage the crown 62 along a substantially horizontal plane. Such engagement enhances the flexibility of the face plate 72 allowing for a greater coefficient of restitution. The crown 62 and the upper lateral extension 76 are secured to each other through welding or the like along the engagement line 81. As illustrated in FIG. 2A, in an alternative embodiment, the upper lateral extension 76 engages the crown 62 at a greater distance inward thereby resulting in a weld that is more rearward from the stresses of the face plate 72 than that of the embodiment of FIG. 2.

[0062] The uniqueness of the present invention is further demonstrated by a hosel section 84 of the face extension 74

that encompasses the aperture 59 leading to the hosel 54. The hosel section 84 has a width w_1 that is greater than a width w_2 of the entirety of the upper lateral extension 76. The hosel section 84 gradually transitions into the heel wall 80. The heel wall 80 is substantially perpendicular to the face plate 72, and the heel wall 80 covers the hosel 54 before engaging a ribbon 90 and a bottom section 91 of the sole 64. The heel wall 80 is secured to the sole 64, both the ribbon 90 and the bottom section 91, through welding or the like.

[0063] At the other end of the face member 60 is the toe wall 82 which arcs from the face plate 72 in a convex manner. The toe wall 82 is secured to the sole 64, both the ribbon 90 and the bottom section 91, through welding or the like.

[0064] The lower lateral extension 78 extends inward, toward the hollow interior 46, a predetermined distance to engage the sole 64. In a preferred embodiment, the predetermined distance ranges from 0.2 inch to 1.0 inch, as measured from the perimeter 73 of the face plate 72 to the end of the lower lateral extension 78. Unlike the prior art which has the sole plate engage the face plate perpendicularly, the present invention has the face member 60 engage the sole 64 along a substantially horizontal plane. The engagement moves the weld heat affected zone rearward from a strength critical crown/face plate radius region. Such engagement enhances the flexibility of the face plate 72 allowing for a greater coefficient of restitution. The sole 64 and the lower lateral extension 78 are secured to each other through welding or the like, along the engagement line 81. The uniqueness of the present invention is further demonstrated by a bore section 86 of the face extension 74 that encompasses a bore 114 in the sole 64 leading to the hosel 54. The bore section 86 has a width w_3 that is greater than a width w_4 of the entirety of the lower lateral extension 78. The bore section 86 gradually transitions into the heel wall 80.

[0065] The crown 62 is generally convex toward the sole 64, and engages the ribbon 90 of sole 64 outside of the engagement with the face member 60. The crown 62 may have a chevron decal 88, or some other form of indicia scribed therein that may assist in alignment of the club head 42 with a golf ball. The crown 62 preferably has a thickness in the range of 0.025 to 0.060 inch, and more preferably in the range of 0.035 to 0.043 inch and most preferably has a thickness of 0.039 inch. The crown 62 is preferably composed of a hot formed or coined material such as a sheet titanium. However, those skilled in the pertinent art will recognize that other materials or forming processes may be utilized for the crown 62 without departing from the scope and spirit of the present invention.

[0066] The sole 64 is generally composed of the bottom section 91 and the ribbon 90, which is substantially perpendicular to the bottom section 91. The bottom section 91 is generally convex toward the crown 62. The bottom section 91 has a medial ridge 92 with a first lateral extension 94 toward the toe section 68 and a second lateral extension 96 toward the heel section 66. The medial ridge 92 and the first lateral extension 94 define a first convex depression 98, and the medial ridge 92 and the second lateral extension 96 define a second convex depression 100. A more detailed explanation of the sole 64 is set forth in U.S. Pat. No. 6,007,433, filed on Apr. 2, 1998, for a Sole Configuration For Golf Club Head,

which is hereby incorporated by reference in its entirety. The sole 64 preferably has a thickness in the range of 0.025 to 0.060 inch, and more preferably 0.047 to 0.055 inch, and most preferably has a thickness of 0.051 inch. The sole 64 is preferably composed of a hot formed or coined metal material such as a sheet titanium material. However, those skilled in the pertinent art will recognize that other materials and forming processes may be utilized for the sole 64 without departing from the scope and spirit of the present invention.

[0067] FIGS. 6-8 illustrate the hollow interior 46 of the club head 42 of the present invention. The hosel 54 is disposed within the hollow interior 46, and is located as a component of the face member 60. The hosel 54 may be composed of a similar material to the face member 60, and is secured to the face member 60 through welding or the like. The hosel 54 is located in the face member 60 to concentrate the weight of the hosel 54 toward the face plate 72, near the heel section 66 in order to contribute to the ball striking mass of the face plate 72. A hollow interior 118 of the hosel 54 is defined by a hosel wall 120 that forms a cylindrical tube between the bore 114 and the aperture 59. In a preferred embodiment, the hosel wall 120 does not engage the heel wall 80 thereby leaving a void 115 between the hosel wall 120 and the heel wall 80. The shaft 48 is disposed within the hosel 54. Further, the hosel 54 is located rearward from the face plate 72 in order to allow for compliance of the face plate 72 during impact with a golf ball. In one embodiment the hosel 54 is disposed 0.125 inch rearward from the face plate 72.

[0068] Optional dual weighting members 122 and 123 may also be disposed within the hollow interior 46 of the club head 42. In a preferred embodiment, the weighting members 122 and 123 are disposed on the sole 64 in order to the lower the center of gravity of the golf club 40. The weighting members 122 and 123, not shown, may have a shape configured to the contour of the sole 64. However, those skilled in the pertinent art will recognize that the weighting member may be placed in other locations of the club head 42 in order to influence the center of gravity, moment of inertia, or other inherent properties of the golf club 40. The weighting members 122 and 123 are preferably a pressed and sintered powder metal material such as a powder titanium material. Alternatively, the weighting members 122 and 123 may be cast or machined titanium chips. Yet further, the weighting members 122 and 123 may be a tungsten screw threadingly engaging an aperture 124 of the sole 64. Although titanium and tungsten have been used as exemplary materials, those skilled in the pertinent art will recognize that other high density materials may be utilized as an optional weighting member without departing from the scope and spirit of the present invention.

[0069] FIGS. 9-11 illustrate variations in the engagement line 81a or 81b. The engagement line 81b illustrates a variation of the face extension 74 of the face member 60. The variation has the engagement line located rearward of the chevron 88. The engagement line 81b is the preferred engagement line.

[0070] FIGS. 12, 12A and 13 illustrate embodiments of the present invention having a variation in the thickness of the face plate 72. The face plate or striking plate 72 is partitioned into elliptical regions, each having a different

thickness. A central elliptical region **102** preferably has the greatest thickness that ranges from 0.110 inch to 0.090 inch, preferably from 0.103 inch to 0.093 inch, and is most preferably 0.095 inch. A first concentric region **104** preferably has the next greatest thickness that ranges from 0.097 inch to 0.082 inch, preferably from 0.090 inch to 0.082 inch, and is most preferably 0.086 inch. A second concentric region **106** preferably has the next greatest thickness that ranges from 0.094 inch to 0.070 inch, preferably from 0.078 inch to 0.070 inch, and is most preferably 0.074 inch. A third concentric region **108** preferably has the next greatest thickness that ranges from 0.090 inch to 0.07 inch. A periphery region **110** preferably has the next greatest thickness that ranges from 0.069 inch to 0.061 inch. The periphery region includes toe periphery region **110a** and heel periphery region **110b**. The variation in the thickness of the face plate **72** allows for the greatest thickness to be distributed in the center **111** of the face plate **72** thereby enhancing the flexibility of the face plate **72** which corresponds to a greater coefficient of restitution.

[**0071**] In an alternative embodiment, the striking plate **72** is composed of a vitreous metal such as iron-boron, nickel-copper, nickel-zirconium, nickel-phosphorous, and the like. These vitreous metals allow for the striking plate **72** to have a thickness as thin as 0.055 inch. Preferably, the thinnest portions of such a vitreous metal striking plate would be in the periphery regions **110a** and **110b**, although the entire striking plate **72** of such a vitreous metal striking plate **72** could have a uniform thickness of 0.055 inch.

[**0072**] Yet in further alternative embodiments, the striking plate **72** is composed of ceramics, composites or other metals. Further, the face plate or striking plate **72** may be an insert for a club head such as wood or iron. Additionally, the thinnest regions of the striking plate **72** may be as low as 0.010 inch allowing for greater compliance and thus a higher coefficient of restitution.

[**0073**] The coefficient of restitution of the club head **42** of the present invention under standard USGA test conditions with a given ball ranges from 0.80 to 0.93, preferably ranges from 0.83 to 0.883 and is most preferably 0.87. The microstructure of titanium material of the face member **60** has a face center cubic (FCC) microstructure as shown in **FIG. 15**, and a body center cubic (BCC) microstructure as shown in **FIG. 16**. The FCC microstructure is associated with alpha-titanium, and the BCC microstructure is associated with beta-titanium.

[**0074**] Additionally, the face plate **72** of the present invention has a smaller aspect ratio than face plates of the prior art (one example of the prior art is shown in **FIG. 14**). The aspect ratio as used herein is defined as the width, w , of the face divided by the height, h , of the face, as shown in **FIG. 1A**. In one embodiment, the width w is 78 millimeters and the height h is 48 millimeters giving an aspect ratio of 1.635. In conventional golf club heads, the aspect ratio is usually much greater than 1. For example, the original GREAT BIG BERTHA® driver had an aspect ratio of 1.9. The face of the present invention has an aspect ratio that is no greater than 1.7. The aspect ratio of the present invention preferably ranges from 1.0 to 1.7. One embodiment has an aspect ratio of 1.3. The face of the present invention is more circular than faces of the prior art. The face area of the face plate **72** of the present invention ranges 4.00 square inches to 7.50

square inches, more preferably from 4.95 square inches to 5.1 square inches, and most preferably from 4.99 square inches to 5.06 square inches.

[**0075**] The club head **42** of the present invention also has a greater volume than a club head of the prior art while maintaining a weight that is substantially equivalent to that of the prior art. The volume of the club head **42** of the present invention ranges from 175 cubic centimeters to 400 cubic centimeters, and more preferably ranges from 300 cubic centimeters to 310 cubic centimeters. The weight of the club head **42** of the present invention ranges from 165 grams to 300 grams, preferably ranges from 175 grams to 225 grams, and most preferably from 188 grams to 195 grams. The depth of the club head from the face plate **72** to the rear section of the crown **62** preferably ranges from 3.606 inches to 3.741 inches. The height, H , of the club head **42**, as measured while in striking position, preferably ranges from 2.22 inches to 2.27 inches, and is most preferably 2.24 inches. The width, W , of the club head **42** from the toe section **68** to the heel section **66** preferably ranges from 4.5 inches to 4.6 inches.

[**0076**] As shown in **FIGS. 17-19**, the flexibility of the face plate **72** allows for a greater coefficient of restitution. At **FIG. 17**, the face plate **72** is immediately prior to striking a golf ball **140**. At **FIG. 18**, the face plate **72** is engaging the golf ball, and deformation of the golf ball **140** and face plate **72** is illustrated. At **FIG. 19**, the golf ball **140** has just been launched from the face plate **72**.

[**0077**] The golf club **42** of the present invention was compared to a golf club head shaped similar to the original GREAT BIG BERTHA® driver to demonstrate how variations in the aspect ratio, thickness and area will effect the COR and stresses of the face plate **72**. However, the GREAT BIG BERTHA® reference had a uniform face thickness of 0.110 inch which is thinner than the original GREAT BIG BERTHA® driver from Callaway Golf Company. The GREAT BIG BERTHA® reference had a COR value of 0.830 while the original GREAT BIG BERTHA® driver had a COR value of 0.788 under test conditions, such as the USGA test conditions specified pursuant to Rule 4-1e, Appendix II of the Rules of Golf for 1998-1999. For a one-hundred mph face center impact for the GREAT BIG BERTHA® reference, the peak stresses were 40 kilopounds per square inch (ksi) for the face-crown, 49 ksi for the face-sole and 29 ksi for the face-center. The face deflection for the GREAT BIG BERTHA® reference at one-hundred mph was 1.25 mm. **FIGS. 20-29** illustrate graphs related to these parameters using the GREAT BIG BERTHA® reference as a base. The face-crown refers to the upper lateral extension **76**, the face-sole refers to the lower lateral extension **78**, and the face-center refers to the center of the face plate **72**.

[**0078**] **FIG. 20** illustrates the percent changes from the stresses on a GREAT BIG BERTHA® reference versus changes in the area of the face plate **72**. As illustrated in the graph, as the area increases the stress on the face-crown increases, and as the area decreases the stress on the face-crown decreases. The stresses on the face-center and the face-sole remain relatively constant as the area of the face plate **72** increases or decreases.

[**0079**] **FIG. 21** illustrates how changes in the area will affect the COR and face deflection. Small changes in the

area will greatly affect the deflection of the face plate 72 while changes to the COR, although relatively smaller percentage changes, are significantly greater in effect. Thus, as the area becomes larger, the face deflection will increase while the COR will increase slightly, but with a significant effect relative to the face deflection.

[0080] FIG. 22 illustrates the percent changes from the stresses on a GREAT BIG BERTHA® reference versus changes in the aspect ratio of the face plate 72. As the aspect ratio of the face plate 72 becomes smaller or more circular, the stress on the face sole greatly increases whereas the stress on the face-center and the face-crown only increases slightly as the aspect ratio decreases.

[0081] FIG. 23 illustrates how changes in the aspect ratio will affect the COR and face deflection. Small changes in the aspect ratio will greatly affect the deflection of the face plate 72 while changes to the COR, although relatively smaller percentage changes, are significantly greater in effect. Thus, as the aspect ratio becomes more circular, the face deflection will increase while the COR will increase slightly, but with a significant effect relative to the face deflection.

[0082] FIG. 24 illustrates the percent changes from the stresses on a GREAT BIG BERTHA® reference versus changes in the thickness ratio. The thickness ratio is defined as the ratio of the face plate 72 to the face thickness of the GREAT BIG BERTHA® reference which has a face thickness of 0.110 inch. As illustrated in the graph, small changes in the thickness ratio will have significant changes in the stress of the face-crown, the face-center and the face-sole.

[0083] FIG. 25 illustrates how changes in the thickness ratio will affect the COR and face deflection. Small changes in the thickness ratio will greatly affect the deflection of the face plate 72 while changes to the COR are significantly smaller in percentage changes.

[0084] FIG. 26 combines FIGS. 21, 23 and 25 to illustrate which changes give the greatest changes in COR for a given percentage change in the face deflection. As illustrated, changing the aspect ratio will give the greatest changes in COR without substantial changes in the face deflection. However, the generic shape of a golf club head dictates that greater total change in COR can be practically achieved by changing the area of the face.

[0085] FIG. 27 combines the face-crown results of FIGS. 20, 22 and 24 to illustrate which changes give the greatest changes in COR relative to face-crown stress. As illustrated, changing the aspect ratio will give the greatest changes in COR with the least changes in the face-crown stress. However, changes in the area should be used to obtain the greater overall change in COR.

[0086] FIG. 28 combines the face-center results of FIGS. 20, 22 and 24 to illustrate which changes give the greatest changes in COR relative face-center stress. As illustrated, changing the area will give the greatest changes in COR with the least changes in the face-center stress.

[0087] FIG. 29 combines the face-sole results of FIGS. 20, 22 and 24 to illustrate which changes give the greatest changes in COR relative to the face-sole stress. Similar to the results for the face-center, changing the area will give the greatest changes in COR with the least changes in the face-sole stress.

[0088] The changes in the thickness ratio provide the least amount of changes in the COR relative to the aspect ratio and the area. However, the golf club head 42 of the present invention utilizes all three, the thickness ratio, the aspect ratio and the area to achieve a greater COR for a given golf ball under test conditions such as the USGA test conditions specified pursuant to Rule 4-1e, Appendix II of the Rules of Golf for 1998-1999. Thus, unlike a spring, the present invention increases compliance of the face plate to reduce energy losses to the golf ball at impact, while not adding energy to the system.

[0089] From the foregoing it is believed that those skilled in the pertinent art will recognize the meritorious advancement of this invention and will readily understand that while the present invention has been described in association with a preferred embodiment thereof, and other embodiments illustrated in the accompanying drawings, numerous changes, modifications and substitutions of equivalents may be made therein without departing from the spirit and scope of this invention which is intended to be unlimited by the foregoing except as may appear in the following appended claims. Therefore, the embodiments of the invention in which an exclusive property or privilege is claimed are defined in the following appended claims.

1. A golf club head comprising:

a body comprising a crown, a sole and a striking plate, the body having a hollow interior defined by the crown, the sole and an interior surface of the striking plate, the striking plate composed of a forged metal material and having a thickness in the range of 0.010 inch to 0.250 inch, the striking plate also having an aspect ratio no greater than 1.7 and a face area ranging from 4.00 square inches to 7.50 square inches; wherein the golf club head has a volume no greater than 400 cubic centimeters and a coefficient of restitution of ranging from 0.83 to 0.93 under standard USGA conditions.

2. The golf club head according to claim 1 wherein the striking plate has a thickness in the range of 0.055 inch to 0.125 inch.

3. The golf club head according to claim 1 wherein the striking plate has a thickness in the range of 0.060 inch to 0.0110 inch.

4. The golf club head according to claim 1 wherein the striking plate is composed of a material selected from the group consisting of titanium, titanium alloys, steels, vitreous metals, ceramics, composites, carbon materials, carbon fiber materials, other fibrous materials and mixtures thereof.

5. The golf club head according to claim 1 wherein the crown is composed of a titanium material and has a thickness ranging from 0.025 inch to 0.060 inch, the sole is composed of a titanium material and has a thickness ranging from 0.025 inch to 0.060 inch, and the golf club head has a mass ranging from 175 grams to 225 grams.

6. The golf club head according to claim 1 wherein the striking plate comprises a central circular region having a base thickness, a first concentric region having a first thickness wherein the base thickness is greater than the first thickness, a second concentric region having a second thickness wherein the first thickness is greater than the second thickness, a third concentric region having a third thickness wherein the second thickness is greater than the

third thickness, and a periphery region having a fourth thickness wherein the fourth thickness is less than the third thickness.

7. The golf club head according to claim 1 wherein the face area of the striking plate ranges from 4.95 square inches to 5.10 square inches.

8. A golf club head comprising:

a face member composed of a forged metal material, the face member comprising a face plate for striking a golf ball having an exterior surface and an interior surface, the face plate extending from a heel section of the golf club head to a toe section of the golf club head, a face extension extending laterally inward from a perimeter of the face plate, and an interior tubing for receiving a shaft, the interior tubing engaging an upper portion of the face extension and a lower portion of the face extension;

a crown secured to the upper portion of the face extension at a distance ranging from 0.2 inch to 1.0 inch from the perimeter of the face plate; and

a sole plate secured to the lower portion of the face extension at a distance ranging from 0.2 inch to 1.0 inch from the perimeter of the face plate;

wherein the golf club head has a volume no greater than 400 cubic centimeters and a coefficient of restitution of ranging from 0.83 to 0.93 under standard USGA conditions.

9. The golf club head according to claim 8 wherein the sole plate has a ribbon section that is secured to the crown.

10. The golf club head according to claim 8 wherein the face plate is composed of a forged titanium material, has a thickness in the range of 0.010 inch to 0.250 inch, has an aspect ratio no greater than 1.7, and has a face area ranging from 4.00 square inches to 7.50 square inches.

11. The golf club head according to claim 8 wherein the sole plate further comprises a medial ridge extending from the face section rearward and dividing the sole plate into a toe section and a heel section.

12. The golf club head according to claim 8 wherein the crown is composed of a titanium material and has a thickness ranging from 0.025 inch to 0.060 inch, the sole is composed of a titanium material and has a thickness ranging from 0.025 inch to 0.060 inch, and the golf club head has a mass ranging from 175 grams to 225 grams.

13. The golf club head according to claim 8 wherein the face plate is composed of a stainless steel material.

14. A golf club head comprising:

a face member comprising

a face plate for striking a golf ball having an exterior surface, an interior surface, and a perimeter, the face plate extending from a heel section of the golf club head to a toe section of the golf club head,

a face extension extending laterally inward along the entire perimeter of the face plate, the face extension having an upper portion, a lower portion opposite the upper portion, a heel wall in the heel section of the golf club head and substantially perpendicular to the face plate, and a toe wall in the toe section of the golf club head, and

an interior tubing for receiving a shaft, the interior tubing engaging the upper portion of the face extension and the lower portion of the face extension;

a crown member secured to the upper portion of the face extension along a non-planar engagement line at a distance ranging from 0.2 inch to 1.0 inch from the perimeter of the face plate; and

a sole member comprising a bottom portion and a ribbon substantially perpendicular to the bottom section, the bottom portion secured to the lower portion of the face extension along a non-planar engagement line at a distance ranging from 0.2 inch to 1.0 inch from the perimeter of the face plate, and the ribbon secured to the crown member.

15. The golf club head according to claim 14 wherein the face member is composed of a forged titanium alloy material, the face plate has a thickness in the range of 0.010 inch to 0.250 inch, and the golf club head has a coefficient of restitution of at least 0.83.

16. The golf club head according to claim 15 wherein the face plate of the face member has a thickness in the range of 0.055 inch to 0.125 inch.

17. The golf club head according to claim 14 wherein the golf club head has a hollow interior, has a volume ranging from 175 cubic centimeters to 400 cubic centimeters, and weighs from 175 grams to 225 grams.

18. The golf club head according to claim 17 further comprising at least one weight member disposed in the hollow interior of the golf club head.

19. The golf club head according to claim 18 wherein the at least one weight member is disposed in the bottom section of the sole member for controlling the center of gravity of the golf club head.

20. The golf club head according to claim 14 wherein the face plate comprises a central circular region having a base thickness, a first concentric region having a first thickness wherein the base thickness is greater than the first thickness, a second concentric region having a second thickness wherein the first thickness is greater than the second thickness, a third concentric region having a third thickness wherein the second thickness is greater than the third thickness, and a periphery region having a fourth thickness wherein the fourth thickness is less than the third thickness.

21. A golf club head comprising:

a face member composed of a forged titanium alloy material, the face member comprising

a face plate for striking a golf ball having an exterior surface, an interior surface, and a perimeter, the face plate extending from a heel section of the golf club head to a toe section of the golf club head,

a face extension extending laterally inward along the entire perimeter of the face plate, the face extension having an upper portion, a lower portion opposite the upper portion, a heel wall in the heel section of the golf club head and substantially perpendicular to the face plate, and a toe wall in the toe section of the golf club head, and

an interior tubing for receiving a shaft, the interior tubing engaging the upper portion of the face extension and the lower portion of the face extension;

- a crown member composed of a coined titanium alloy material and having a thickness ranging from 0.025 inch to 0.06 inch, the crown member secured to the upper portion of the face extension along a non-planar engagement line at a distance ranging from 0.2 inch to 1.0 inch from the perimeter of the face plate; and
 - a sole member composed of a coined titanium alloy material and having a thickness ranging from 0.025 inch to 0.06 inch, the sole member comprising a bottom portion and a ribbon substantially perpendicular to the bottom section, the bottom portion secured to the lower portion of the face extension along a non-planar engagement line at a distance ranging from 0.2 inch to 1.0 inch from the perimeter of the face plate, and the ribbon secured to the crown member.
- 22.** A golf club heads according to claim 21 wherein the aspect ratio of the face plate is between 1.0 and 1.2.
- 23.** The golf club head according to claim 21 wherein the face plate has a coefficient of restitution that ranges from 0.83 to 0.93.
- 24.** A golf club head comprising:
- a face member composed of a forged titanium alloy material, the face member comprising
 - a face plate for striking a golf ball having an exterior surface, an interior surface, and a perimeter, the face plate having concentric regions of varying thickness with the thickest region in the center,
 - a face extension extending laterally inward along the entire perimeter of the face plate, the face extension having an upper portion, a lower portion opposite the upper portion, a heel wall in the heel section of the golf club head and substantially perpendicular to the face plate, and a toe wall in the toe section of the golf club head, and an interior tubing for receiving a shaft, the interior tubing engaging the upper portion of the face extension and the lower portion of the face extension;
 - a crown member secured to the upper portion of the face extension along a non-planar engagement line at a distance ranging from 0.2 inch to 1.0 inch from the perimeter of the face plate; and
 - a sole member comprising a bottom portion and a ribbon substantially perpendicular to the bottom section, the bottom portion secured to the lower portion of the face extension along a non-planar engagement line at a distance ranging from 0.2 inch to 1.0 inch from the perimeter of the face plate, and the ribbon secured to the crown member.
- 25.** The golf club head according to claim 24 wherein the face has a coefficient of restitution of 0.87 as measured according to USGA Standards.

* * * * *