

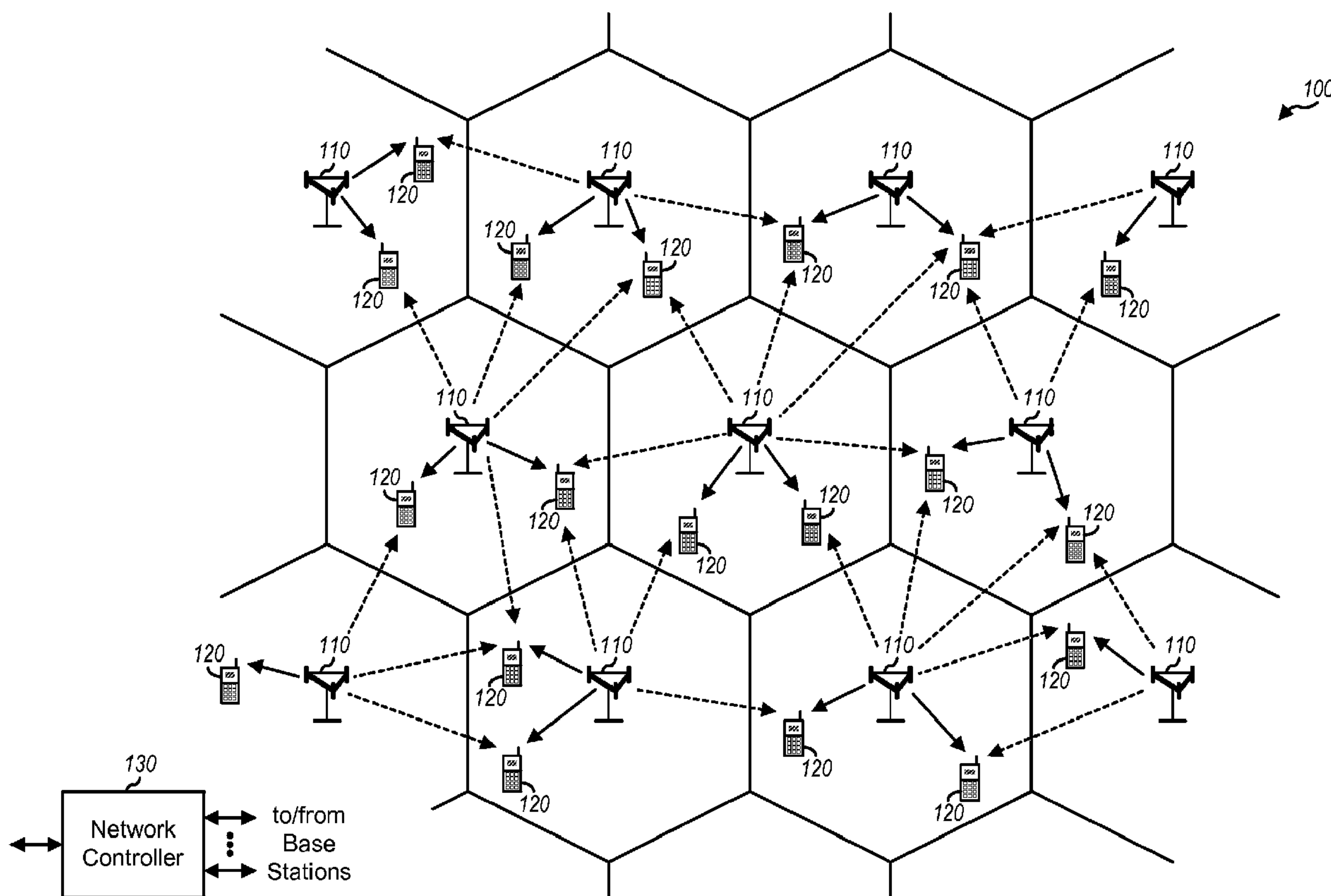

(86) Date de dépôt PCT/PCT Filing Date: 2009/07/31
 (87) Date publication PCT/PCT Publication Date: 2010/02/04
 (45) Date de délivrance/Issue Date: 2014/08/05
 (85) Entrée phase nationale/National Entry: 2011/01/11
 (86) N° demande PCT/PCT Application No.: US 2009/052515
 (87) N° publication PCT/PCT Publication No.: 2010/014968
 (30) Priorités/Priorities: 2008/08/01 (US61/085,757);
 2009/06/18 (US12/487,580)

(51) Cl.Int./Int.Cl. *H04W 48/16* (2009.01)
 (72) Inventeurs/Inventors:
 WANG, MICHAEL M., US;
 PALANKI, RAVI, US;
 BHUSHAN, NAGA, US
 (73) Propriétaire/Owner:
 QUALCOMM INCORPORATED, US
 (74) Agent: SMART & BIGGAR

(54) Titre : DETECTION DE CELLULE AVEC ANNULATION DE BROUILLAGE
 (54) Title: CELL DETECTION WITH INTERFERENCE CANCELLATION



(57) Abrégé/Abstract:

Techniques for performing cell detection with interference cancellation are described. In an aspect, a user equipment (UE) may detect for pilots from cells in a wireless network using interference cancellation. The UE may process a received signal to detect for pilots from one or more cells. The pilots may be common pilots transmitted with a reuse factor of one or low reuse pilots transmitted with a reuse factor greater than one. The UE may estimate the interference from a detected cell (e.g., the strongest detected cell)

(57) **Abrégé(suite)/Abstract(continued):**

and may cancel the estimated interference from the received signal. The UE may then process the interference-canceled signal to detect for pilots from additional cells. The UE may be able to detect pilots from more cells, e.g., from weaker cells, by canceling the interference due to the pilots from the detected cells. This may be desirable for various applications such as positioning.

(12) INTERNATIONAL APPLICATION PUBLISHED UNDER THE PATENT COOPERATION TREATY (PCT)

(19) World Intellectual Property Organization
International Bureau(43) International Publication Date
4 February 2010 (04.02.2010)(10) International Publication Number
WO 2010/014968 A1(51) International Patent Classification:
H04W 48/16 (2009.01)(21) International Application Number:
PCT/US2009/052515(22) International Filing Date:
31 July 2009 (31.07.2009)

(25) Filing Language: English

(26) Publication Language: English

(30) Priority Data:
61/085,757 1 August 2008 (01.08.2008) US
12/487,580 18 June 2009 (18.06.2009) US(71) Applicant (for all designated States except US): **QUALCOMM INCORPORATED** [US/US]; Attn: International IP Administration, 5775 Morehouse Drive, San Diego, CA 92121 (US).

(72) Inventors; and

(75) Inventors/Applicants (for US only): **WANG, Michael, M.** [US/US]; 5775 Morehouse Drive, San Diego, CA 92121 (US). **PALANKI, Ravi** [IN/US]; 5775 Morehouse Drive, San Diego, CA 92121 (US). **BHUSHAN, Naga** [US/US]; 5775 Morehouse Drive, San Diego, CA 92121 (US).(74) Agent: **CORIE, Florin, C.**; Attn: International IP Administration, 5775 Morehouse Drive, San Diego, CA 92121 (US).

(81) Designated States (unless otherwise indicated, for every kind of national protection available): AE, AG, AL, AM, AO, AT, AU, AZ, BA, BB, BG, BH, BR, BW, BY, BZ, CA, CH, CL, CN, CO, CR, CU, CZ, DE, DK, DM, DO, DZ, EC, EE, EG, ES, FI, GB, GD, GE, GH, GM, GT, HN, HR, HU, ID, IL, IN, IS, JP, KE, KG, KM, KN, KP, KR, KZ, LA, LC, LK, LR, LS, LT, LU, LY, MA, MD, ME, MG, MK, MN, MW, MX, MY, MZ, NA, NG, NI, NO, NZ, OM, PE, PG, PH, PL, PT, RO, RS, RU, SC, SD, SE, SG, SK, SL, SM, ST, SV, SY, TJ, TM, TN, TR, TT, TZ, UA, UG, US, UZ, VC, VN, ZA, ZM, ZW.

(84) Designated States (unless otherwise indicated, for every kind of regional protection available): ARIPO (BW, GH, GM, KE, LS, MW, MZ, NA, SD, SL, SZ, TZ, UG, ZM, ZW), Eurasian (AM, AZ, BY, KG, KZ, MD, RU, TJ, TM), European (AT, BE, BG, CH, CY, CZ, DE, DK, EE, ES, FI, FR, GB, GR, HR, HU, IE, IS, IT, LT, LU, LV, MC, MK, MT, NL, NO, PL, PT, RO, SE, SI, SK, SM, TR), OAPI (BF, BJ, CF, CG, CI, CM, GA, GN, GQ, GW, ML, MR, NE, SN, TD, TG).

Declarations under Rule 4.17:

- as to applicant's entitlement to apply for and be granted a patent (Rule 4.17(ii))
- as to the applicant's entitlement to claim the priority of the earlier application (Rule 4.17(iii))

Published:

- with international search report (Art. 21(3))

(54) Title: CELL DETECTION WITH INTERFERENCE CANCELLATION

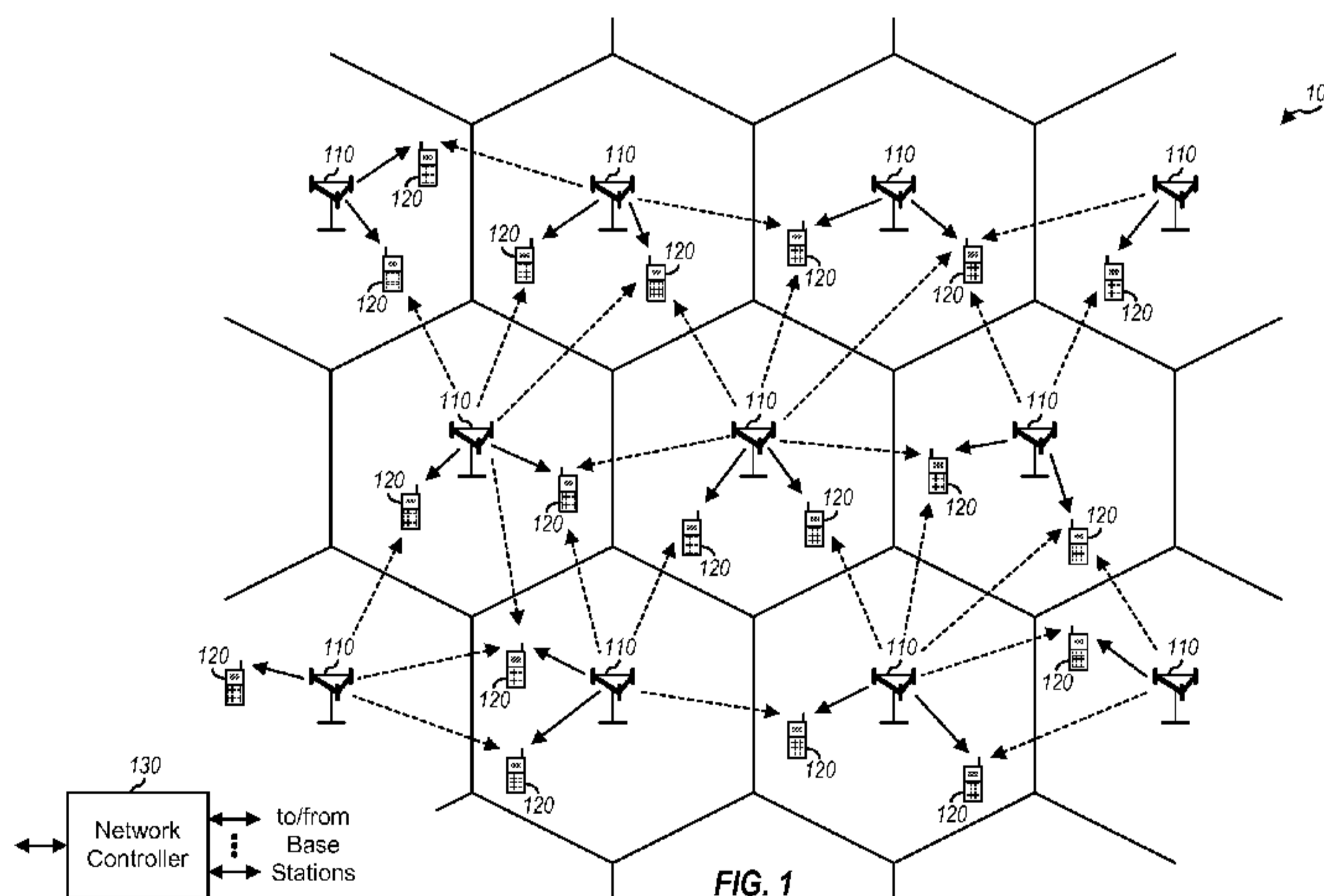

(57) **Abstract:** Techniques for performing cell detection with interference cancellation are described. In an aspect, a user equipment (UE) may detect for pilots from cells in a wireless network using interference cancellation. The UE may process a received signal to detect for pilots from one or more cells. The pilots may be common pilots transmitted with a reuse factor of one or low reuse pilots transmitted with a reuse factor greater than one. The UE may estimate the interference from a detected cell (e.g., the strongest detected cell) and may cancel the estimated interference from the received signal. The UE may then process the interference-canceled signal to detect for pilots from additional cells. The UE may be able to detect pilots from more cells, e.g., from weaker cells, by canceling the interference due to the pilots from the detected cells. This may be desirable for various applications such as positioning.



WO 2010/014968 A1

CELL DETECTION WITH INTERFERENCE CANCELLATION

[0001]

BACKGROUND

I. Field

[0002] The present disclosure relates generally to communication, and more specifically to techniques for detecting for cells in a wireless communication network.

II. Background

[0003] Wireless communication networks are widely deployed to provide various communication content such as voice, video, packet data, messaging, broadcast, etc. These wireless networks may be multiple-access networks capable of supporting multiple users by sharing the available network resources. Examples of such multiple-access networks include Code Division Multiple Access (CDMA) networks, Time Division Multiple Access (TDMA) networks, Frequency Division Multiple Access (FDMA) networks, Orthogonal FDMA (OFDMA) networks, and Single-Carrier FDMA (SC-FDMA) networks.

[0004] A wireless communication network may include a number of cells that can support communication for a number of user equipments (UEs). A UE may be within the coverage of one or more cells at any given moment, e.g., depending on the current UE location. The UE may not know which cells are within range. The UE may perform a search to detect for cells and to acquire timing and other information for the detected cells. It may be desirable to detect for cells in a manner to obtain good performance, e.g., to detect as many cells as possible.

74769-3285

2

SUMMARY

[0005] Techniques for performing cell detection with interference cancellation are described herein. In an aspect, a UE may detect for pilots from cells in a wireless network using interference cancellation, which may enable the UE to detect pilots from more cells.

5 For cell detection with interference cancellation, the UE may process a received signal to detect for pilots from one or more cells. The pilots may comprise common pilots transmitted with a reuse factor of one or low reuse pilots transmitted with a reuse factor greater than one. The UE may estimate the interference due to a detected cell (e.g., the strongest detected cell) and may cancel the estimated interference from the received signal. The UE may then process
10 the interference-canceled signal to detect for pilots from additional cells. The UE may be able to detect pilots from more cells, e.g., from weaker cells, by canceling the interference due to the pilots from the detected cells. This may be desirable for various applications such as positioning.

[0006] Various aspects and features of the disclosure are described in further detail below.

15 **[0006a]** According to one aspect of the present invention, there is provided a method of detecting for cells in a wireless communication network, comprising: obtaining a received signal comprising pilots transmitted by a plurality of cells in the wireless network; and processing the received signal with interference cancellation to detect for the pilots from the plurality of cells, the interference cancellation improving the number of detected cells,
20 wherein the processing of the received signal comprises performing pilot detection and interference cancellation of the received signal in multiple stages, and for each stage: detecting one or more of the pilots in the received signal from one or more of the plurality of cells; selecting at least one cell for interference cancellation from the one or more of the plurality of cells based in part on the one or more pilots; deriving a channel estimate for the
25 selected cell after canceling interference from prior selected cells from the received signal; generating a pilot for the selected cell; estimating interference due to the selected cell based on the generated pilot and the channel estimate for the selected cell; and canceling

74769-3285

2a

interference due to the selected cell from the received signal based on the estimated interference.

[0006b] According to another aspect of the present invention, there is provided an apparatus for wireless communication, comprising: means for obtaining a received signal
5 comprising pilots transmitted by a plurality of cells in a wireless communication network; and means for processing the received signal with interference cancellation to detect for the pilots from the plurality of cells, the interference cancellation improving the number of detected cells, including: means for performing pilot detection and interference cancellation in multiple stages, means for detecting one or more of the pilots in the received signal from one or more
10 of the plurality of cells in each of the multiple stages, means for selecting at least one cell from the one or more of the plurality of cells based in part on the one or more pilots in each of the multiple stages, means for deriving a channel estimate for the selected cell after canceling interference from prior selected cells from the received signal in each of the multiple stages, means for generating a pilot for the selected cell in each of the multiple stages, means for
15 estimating interference due to the selected cell based on the generated pilot and the channel estimate for the selected cell in each of the multiple stages, and means for canceling interference due to the selected cell from the received signal based on the estimated interference in each of the multiple stages.

[0006c] According to still another aspect of the present invention, there is provided an
20 apparatus for wireless communication, comprising: at least one processor configured to: obtain a received signal comprising pilots transmitted by a plurality of cells in a wireless communication network; and process the received signal to detect for the pilots from the plurality of cells at least in part by performing pilot detection and interference cancellation in multiple stages and, for each stage: detecting one or more of the pilots in the received signal
25 from one or more of the plurality of cells, selecting at least one cell from the one or more of the plurality of cells based in part on the one or more pilots, deriving a channel estimate for the selected cell after canceling interference from prior selected cells from the received signal, generating a pilot for the selected cell, estimating interference due to the selected cell based on the generated pilot and the channel estimate for the selected cell, and canceling

74769-3285

2b

interference due to the selected cell from the received signal based on the estimated interference.

[0006d] According to yet another aspect of the present invention, there is provided a computer program product comprising a non-transitory computer-readable storage medium
5 having stored thereon computer-executable instructions that, when executed by at least one computer, cause the at least one computer to: obtain a received signal comprising pilots transmitted by a plurality of cells in a wireless communication network, and process the received signal to detect for the pilots from the plurality of cells at least in part by performing pilot detection and interference cancellation in multiple stages and, for each stage: detecting
10 one or more of the pilots from one or more cells, selecting at least one cell for interference cancellation from among the one or more detected cells, deriving a channel estimate for the selected cell after canceling interference from prior selected cells from the received signal; generating a pilot for the selected cell; estimating interference due to the selected cell based on the generated pilot and the channel estimate for the selected cell; and canceling
15 interference due to the selected cell based on the estimated interference.

BRIEF DESCRIPTION OF THE DRAWINGS

- [0007] FIG. 1 shows a wireless communication network.
- [0008] FIG. 2 shows an exemplary transmission structure for a low reuse pilot.
- [0009] FIG. 3 shows transmission of a low reuse pilot by one cell.
- 20 [0010] FIG. 4 shows another exemplary transmission structure for a low reuse pilot.
- [0011] FIG. 5 shows a block diagram of a base station and a UE.
- [0012] FIG. 6 shows a block diagram of a pilot processor/searcher at the UE.
- [0013] FIGS. 7A to 7D show detection performance for four cell detection schemes for common pilots and low reuse pilots, with and without interference cancellation.

74769-3285

2c

- [0014]** FIG. 8 shows plots of cumulative distribution function (CDF) of number of detected cells for the four cell detection schemes.
- [0015]** FIG. 9 shows plots of CDF of location error for the four cell detection schemes.
- 5 **[0016]** FIG. 10 shows a process for performing cell detection by a UE.
- [0017]** FIG. 11 shows a process for performing successive detection and cancellation.
- [0018]** FIG. 12 shows an apparatus for performing cell detection.

DETAILED DESCRIPTION

[0019] The techniques described herein may be used for various wireless communication networks such as CDMA, TDMA, FDMA, OFDMA, SC-FDMA and other networks. The terms “network” and “system” are often used interchangeably. A CDMA network may implement a radio technology such as Universal Terrestrial Radio Access (UTRA), cdma2000, etc. UTRA includes Wideband CDMA (WCDMA) and other variants of CDMA. cdma2000 covers IS-2000, IS-95 and IS-856 standards. A TDMA network may implement a radio technology such as Global System for Mobile Communications (GSM). An OFDMA network may implement a radio technology such as Evolved UTRA (E-UTRA), Ultra Mobile Broadband (UMB), IEEE 802.11 (Wi-Fi), IEEE 802.16 (WiMAX), IEEE 802.20, Flash-OFDM®, etc. UTRA and E-UTRA are part of Universal Mobile Telecommunication System (UMTS). 3GPP Long Term Evolution (LTE) and LTE-Advanced (LTE-A) are new releases of UMTS that use E-UTRA, which employs OFDMA on the downlink and SC-FDMA on the uplink. UTRA, E-UTRA, UMTS, LTE, LTE-A and GSM are described in documents from an organization named “3rd Generation Partnership Project” (3GPP). cdma2000 and UMB are described in documents from an organization named “3rd Generation Partnership Project 2” (3GPP2). The techniques described herein may be used for the wireless networks and radio technologies mentioned above as well as other wireless networks and radio technologies.

[0020] FIG. 1 shows a wireless communication network 100 with multiple base stations 110. A base station may be a station that communicates with the UEs and may also be referred to as a Node B, an evolved Node B (eNB), an access point, etc. Each base station 110 may provide communication coverage for a particular geographic area. In 3GPP, the term “cell” can refer to a coverage area of a base station and/or a base station subsystem serving this coverage area, depending on the context in which the term is used. In 3GPP2, the term “sector” or “cell-sector” can refer to a coverage area of a base station and/or a base station subsystem serving this coverage area. For clarity, 3GPP2 concept of “cell” is used in the description below. A base station may support one or multiple (e.g., three) cells.

[0021] Wireless network 100 may be a homogeneous network that includes base stations of one type, e.g., only macro base stations. Wireless network 100 may also be a

heterogeneous network that includes base stations of different types, e.g., macro, pico, and/or femto base stations that provide coverage for macro, pico and/or femto cells, respectively. A macro base station may cover a relatively large geographic area (e.g., several kilometers in radius) and may allow unrestricted access by terminals with service subscription. A pico base station may cover a relatively small geographic area and may allow unrestricted access by terminals with service subscription. A femto or home base station may cover a relatively small geographic area (e.g., a home) and may allow restricted access by terminals having association with the femto cell (e.g., terminals for users in the home). Wireless network 100 may also include relay stations. The techniques described herein may be used for both homogeneous and heterogeneous networks. A network controller 130 may couple to a set of base stations and provide coordination and control for the base stations.

[0022] UEs 120 may be dispersed throughout wireless network 100, and each UE may be stationary or mobile. A UE may also be referred to as a mobile station, a terminal, a subscriber unit, a station, etc. A UE may be a cellular phone, a personal digital assistant (PDA), a wireless modem, a wireless communication device, a handheld device, a laptop computer, a cordless phone, a wireless local loop (WLL) station, etc. A UE may communicate with a base station via the downlink and uplink. The downlink (or forward link) refers to the communication link from the base station to the UE, and the uplink (or reverse link) refers to the communication link from the UE to the base station. In FIG. 1, a solid line with a single arrow indicates a UE receiving a data transmission from a serving cell, and a dashed line with a single arrow indicates a UE receiving pilot from a cell. Uplink transmissions are not shown in FIG. 1.

[0023] Wireless network 100 may utilize a reuse factor of one, which means that a given frequency channel may be used by all cells in the wireless network. Using a reuse factor of one may improve spectral efficiency and may also reduce complexity of frequency planning in wireless network 100.

[0024] Each cell in wireless network 100 may transmit a common pilot, which may be used by UEs for cell detection, time synchronization, channel estimation, etc. A pilot is a signal or transmission that is known *a priori* by a transmitter and a receiver. A pilot may also be referred to as a reference signal, a preamble, etc. A common pilot is a pilot transmitted to all UEs. A common pilot may also be referred to as a cell-specific reference signal, etc.

[0025] Each cell may also transmit a low reuse pilot (LRP), which may have wider coverage and better hearability than the common pilot. A low reuse pilot is a pilot that is transmitted with a reuse factor greater than one, so that only a fraction of the cells transmit their low reuse pilots on a given time and/or frequency resource. For example, with a reuse factor of M , where $M > 1$, only one out of every M cells may transmit its low reuse pilot on a given resource. A higher reuse factor (i.e., a larger value of M) corresponds to lower reuse, and vice versa. A low reuse pilot from a given cell may observe less interference from low reuse pilots from other cells, which may enable detection of the low reuse pilot by more UEs. A low reuse pilot may also be referred to as a highly detectable pilot (HDP), a positioning assistance reference signal (PA-RS), a low reuse preamble, etc. A UE may be able to detect cells farther away based on the low reuse pilots transmitted by these cells.

[0026] A UE may have difficulty detecting the common pilots from neighboring cells due to strong interference from the closest cells. This near-far effect may result in a hearability problem, which may reduce accuracy of cellular network-based positioning of the UE. The hearability problem may be mitigated by increasing pilot processing gain, e.g., by transmitting more pilot symbols for the common pilots on more resources and/or transmitting the common pilots at higher transmit power. However, pilot processing gain may not be a feasible solution to the near-far problem due to physical resource limitation and/or channel coherence time.

[0027] The low reuse pilots can reduce the adverse effect of a dominant cell on the detection of other cells. The cells may transmit their low reuse pilots in accordance with a multiplexing pattern. Each cell may transmit its low reuse pilot with a probability of $p = 1/M$ in each LRP transmission opportunity and may transmit its low reuse pilot once every M LRP transmission opportunities. Each cell may transmit its low reuse pilot in various manners. Several exemplary designs of low reuse pilots are described below.

[0028] **FIG. 2** shows an exemplary transmission structure for low reuse pilots in a High Rate Packet Data (HRPD) network that implements IS-856. A low reuse pilot may be referred to as a highly detectable pilot (HDP) in HRPD. In HRPD, the transmission timeline for the downlink may be partitioned into units of slots, with each slot having a duration of 1.667 milliseconds (ms). The transmission timeline may also

be partitioned into pilot cycles with sequentially increasing indices. Each pilot cycle may cover N slots with indices of 0 through $N-1$, where N may be equal to 768, 2304, or some other value. In each pilot cycle, M slots with indices of t_0, t_1, \dots, t_{M-1} may be available for sending HDP and may be referred to as HDP slots. M may be equal to 9 (for HRPD, as shown in FIG. 2) or some other value. M may be a small percentage of N , so that overhead due to HDP may be negligible. The M HDP slots t_0 to t_{M-1} may be dependent on the value of N and may be known by the cells and the UEs.

[0029] A given cell x may transmit its HDP in one HDP slot in each pilot cycle. Cell x may select one HDP slot in each pilot cycle based on a pseudo-random function, as follows:

$$q = f(\text{PilotPN}, \text{Cell-ID}, \text{Time}), \quad \text{Eq (1)}$$

where PilotPN is a pseudo-random number (PN) sequence assigned to the cell,

Cell-ID is an identity of the cell,

Time denotes absolute time,

$f(\)$ denotes a pseudo-random function, and

$q \in \{0, \dots, M-1\}$ is a random integer that determines the selected HDP slot.

[0030] FIG. 3 shows transmission of HDP by one cell x in HRPD. Cell x may provide its PilotPN, its Cell-ID, and a pilot cycle index s for Time to the pseudo-random function. In pilot cycle s , the pseudo-random function may output a value $q(s)$, and cell x may transmit its HDP in slot $t_{q(s)}$. In the next pilot cycle $s+1$, the pseudo-random function may output a value $q(s+1)$, and cell x may transmit its HDP in slot $t_{q(s+1)}$. Cell x may transmit its HDP in a similar manner in each subsequent pilot cycle.

[0031] Cell x may generate an HDP transmission for an HDP slot by spreading a predefined symbol sequence (e.g., all zeros) with a Walsh sequence, scaling the resultant bits, and scrambling the scaled bits with the PN sequence assigned to cell x . The HDP transmission may thus carry only the assigned PN sequence.

[0032] As shown in FIGS. 2 and 3, cell x may transmit its HDP in one of M (e.g., $M=9$) available HDP slots in each pilot cycle. A reuse factor of M may thus be achieved for the HDP in HRPD. Furthermore, cell x may transmit its HDP in different HDP slots in different pilot cycles in order to avoid continually colliding with the HDP

from a strong neighbor cell. These features may allow more UEs to detect the HDP from cell x. In contrast, all cells in the HRPD network may transmit their common pilots in the same pilot time segments in each slot. The common pilot from cell x may thus be transmitted with a reuse factor of one, may observe more interference from the neighbor cells, and may be less detectable than the HDP from cell x.

[0033] Low reuse pilots may also be transmitted on the downlink in LTE. LTE utilizes orthogonal frequency division multiplexing (OFDM) on the downlink and single-carrier frequency division multiplexing (SC-FDM) on the uplink. OFDM and SC-FDM partition the system bandwidth into multiple (K) orthogonal subcarriers, which are also commonly referred to as tones, bins, etc. Each subcarrier may be modulated with data. In general, modulation symbols are sent in the frequency domain with OFDM and in the time domain with SC-FDM. The spacing between adjacent subcarriers may be fixed, and the total number of subcarriers (K) may be dependent on the system bandwidth. For example, the spacing between adjacent subcarriers may be 15 KHz, and K may be equal to 83, 166, 333, 666 or 1333 for system bandwidth of 1.25, 2.5, 5, 10 or 20 MHz, respectively.

[0034] FIG. 4 shows an exemplary transmission structure for low reuse pilots in an LTE network. A low reuse pilot may be referred to as a positioning assistance reference signal (PA-RS) in LTE. In LTE, the transmission timeline for the downlink may be partitioned into units of radio frames. Each radio frame may have a duration of 10 ms and may be partitioned into 10 subframes with indices of 0 through 9. Each subframe may include two slots, and each slot may include seven symbol periods for a normal cyclic prefix (as shown in FIG. 4) or six symbol periods for an extended cyclic prefix (not shown in FIG. 4). The 14 symbol periods in each subframe for the normal cyclic prefix may be assigned indices of 0 through 13. Each symbol period may include a number of resource elements. Each resource element may cover one subcarrier in one symbol period and may be used to send one symbol, which may be a real or complex value.

[0035] A given cell x may transmit a cell-specific reference signal (or simply, a reference signal) on certain subcarriers in certain symbol periods of each subframe. In particular, for the case with two transmit antennas with the normal cyclic prefix, cell x may transmit the reference signal on every third subcarriers starting with subcarrier k_0 in symbol periods 0, 4, 7 and 11 of each subframe. The starting subcarrier k_0 may be

determined based on a physical cell identity (PCI) of cell x. Cell x may transmit control information in the first L symbol periods of a subframe, with $L = 2$ in FIG. 4. In general, $L \leq 3$ and may be configurable for each subframe.

[0036] Cell x may also transmit a PA-RS in a subframe designated for PA-RS transmission. In the design shown in FIG. 4, cell x may transmit the PA-RS in each symbol period not use for the reference signal or control information. A symbol period with a PA-RS transmission may be referred to as a PA-RS symbol period. In each PA-RS symbol period, cell x may transmit the PA-RS on every sixth subcarrier starting with a particular subcarrier. Different starting subcarriers may be used in different PA-RS symbol periods, e.g., as shown in FIG. 4, to allow the PA-RS to be transmitted on all or most of the K total subcarriers. The starting subcarriers may change over time, to avoid continual collision with the PA-RS from the same strong neighbor cell. This may allow UEs to obtain a more accurate time measurement for cell x based on the PA-RS.

[0037] Cell x may generate an OFDM symbol comprising a PA-RS transmission in various manners. In one design, cell x may generate a sample sequence based on its cell ID, permute or shuffle the sample sequence, generate modulation symbols based on the permuted samples, map the modulation symbols to subcarriers used for the PA-RS, and generate an OFDM symbol with the mapped modulation symbols. The sample sequence may be generated in similar manner as a sample sequence for a synchronization signal in order to reduce implementation complexity. The sample sequence may be permuted in different manners for different PA-RS symbol periods. Cell x may also generate an OFDM symbol with the PA-RS transmission in other manners.

[0038] In the design shown in FIG. 4, cell x may transmit its PA-RS on every sixth subcarrier in each PA-RS symbol period. A reuse factor of six may thus be achieved for the PA-RS in LTE. Furthermore, cell x may transmit its PA-RS on different subcarriers in different PA-RS symbol periods to avoid continually colliding with the PA-RS from a strong neighbor cell. Cell x may also transmit its PA-RS at a higher transmit power level since no other transmissions may be sent on the other subcarriers in each PA-RS symbol period. These features may allow more UEs to detect the PA-RS from cell x. In contrast, each cell in the LTE network may transmit its reference signal on every third subcarriers, e.g., as shown in FIG. 4, for a pilot reuse factor of three. However, the reference signal from each cell may observe interference from data transmissions sent

by neighbor cells, may have an actual reuse factor of one, and may be less detectable than the PA-RS from the cell.

[0039] FIGS. 2 and 3 show an example of time multiplexing for the low reuse pilots to reduce the likelihood of collision between low reuse pilots from strong and weak cells. FIG. 4 shows an example of frequency multiplexing for the low reuse pilots to reduce the likelihood of collision between low reuse pilots from strong and weak cells. Low reuse pilots may also be transmitted with other multiplexing schemes. In any case, the low reuse pilots may allow UEs to detect pilots from more cells, including pilots from weaker cells. However, the improved hearability comes at a cost since a given resource (e.g., a slot in HRPD or a resource element in LTE) is used by only a fraction of the cells in the wireless network.

[0040] In an aspect, a UE may detect for pilots from cells in the wireless network using interference cancellation, which may enable the UE to detect pilots from more cells. For cell detection with interference cancellation, the UE may process a received signal to detect for pilots from one or more cells. The UE may estimate the interference due to a detected cell (e.g., the strongest detected cell) and may cancel the estimated interference from the received signal. The UE may be able to detect pilots from more cells, e.g., from weaker cells, by canceling the interference due to the pilots from the detected cells. Interference cancellation may improve the hearability of weaker cells and may be used for both the low reuse pilots and the common pilots.

[0041] FIG. 5 shows a block diagram of a design of a base station 110 and a UE 120, which may be one of the base stations and one of the UEs in FIG. 1. Base station 110 may support one or more cells. Base station 110 may be equipped with T antennas 534a through 534t, and UE 120 may be equipped with R antennas 552a through 552r, where in general $T \geq 1$ and $R \geq 1$.

[0042] At base station 110, a transmit processor 520 may receive data for one or more UEs from a data source 512, process (e.g., encode, interleave, and symbol map) the data for each UE, and provide data symbols for all UEs. Transmit processor 520 may also process control information from a controller/processor 540 and provide control symbols. Transmit processor 520 may also generate pilot symbols for a low reuse pilot, a common pilot, and/or other pilots or reference signals for each cell supported by base station 110. A transmit (TX) multiple-input multiple-output (MIMO) processor 530 may perform precoding on the data symbols, the control symbols, and/or

the pilot symbols, if applicable. Processor 530 may provide T output symbol streams to T modulators (MODs) 532a through 532t. Each modulator 532 may process a respective output symbol stream (e.g., for CDMA, OFDM, etc.) to obtain an output sample stream. Each modulator 532 may further process (e.g., convert to analog, amplify, filter, and upconvert) the output sample stream to obtain a downlink signal. T downlink signals from modulators 532a through 532t may be transmitted via T antennas 534a through 534t, respectively.

[0043] At UE 120, antennas 552a through 552r may receive the downlink signals from base station 110 and other base stations and may provide received signals to demodulators (DEMODOs) 554a through 554r, respectively. Each demodulator 554 may condition (e.g., filter, amplify, downconvert, and digitize) a respective received signal to obtain input samples. Each demodulator 554 may further process the input samples (e.g., for CDMA, OFDM, etc.) to obtain received symbols. A MIMO detector 556 may obtain received symbols from all R demodulators 554a through 554r, perform receiver spatial processing on the received symbols if applicable, and provide detected symbols. A receive processor 558 may process (e.g., demodulate, deinterleave, and decode) the detected symbols, provide decoded data for UE 120 to a data sink 560, and provide decoded control information to a controller/processor 580. A pilot processor/searcher 584 may receive input samples from all demodulators 554 and may detect for pilots from cells, as described below.

[0044] On the uplink, at UE 120, a transmit processor 564 may receive and process data from a data source 562 and control information (e.g., for detected cells, time measurements, etc.) from controller/processor 580. Transmit processor 564 may also generate pilot symbols. The symbols from transmit processor 564 may be precoded by a TX MIMO processor 566 if applicable, further processed by modulators 554a through 554r, and transmitted to base station 110. At base station 110, the uplink signals from UE 120 and other UEs may be received by antennas 534, processed by demodulators 532, detected by a MIMO detector 536 if applicable, and further processed by a receive processor 538 to obtain decoded data and control information transmitted by the UEs.

[0045] Controllers/processors 540 and 580 may direct the operation at base station 110 and UE 120, respectively. Memories 542 and 582 may store data and program codes for base station 110 and UE 120, respectively. A scheduler 544 may schedule

UEs for data transmission on the downlink and/or uplink and may provide resource grants for the scheduled UEs.

[0046] FIG. 6 shows a block diagram of a design of pilot processor/searcher 584 at UE 120 in FIG. 5. In this design, pilot processor 584 may perform pilot detection and interference cancellation in multiple stages 610. For simplicity, only two stages 610a and 610b are shown in FIG. 6.

[0047] In the first stage 610a, a pilot detector 612a may receive the input samples from demodulators 554, detect for pilots (e.g., low reuse pilots) transmitted by cells based on the input samples, and provide the strength and timing of each detected cell. Pilot detector 612a may detect for pilots in a manner that is dependent on how the pilots are generated and transmitted by the cells. In one design, pilot detector 612a may locally generate a sample sequence for a pilot from a cell to be detected. The locally generated sample sequence may be for a PN sequence assigned to the cell in HRPD, an OFDM symbol comprising a PA-RS transmission in LTE, etc. Pilot detector 612a may correlate the input samples with the locally generated sample sequence at different time offsets to obtain correlation results for different time offsets for the cell. Pilot detector 612a may determine that the cell is detected if the correlation result for any time offset exceeds a detection threshold. In one design, UE 120 may receive a list of potential cells (e.g., from a serving cell), and pilot detector 612a may detect for each cell in the list. In another design, pilot detector 612a may detect for each possible cell by cycling through all possible cell IDs, e.g., all 504 cell IDs in LTE. For all designs, pilot detector 612a may provide a list of detected cells, the energy and timing of each detected, and/or other information. The energy of each detected cell may be the energy of a correlation peak for the cell.

[0048] A sorter 614a may receive the search results from pilot detector 612a and may sort the energies of the detected cells. Sorter 614a may select one or more detected cells for interference cancellation and may provide the identity of each selected cell to an interference estimator 616a. Sorter 614a may select one or more cells for interference cancellation in various manners, as described above.

[0049] Interference estimator 616a may receive the selected cell(s) from sorter 614a and the input samples and may estimate the interference due to the pilot from each selected cell. To estimate the interference due to a given selected cell, interference estimator 616a may derive a channel estimate for the selected cell based on the input

samples (e.g., using the common pilot transmitted by the cell). Interference estimator 616a may locally generate the pilot from the selected cell in the same manner as the cell and may apply the locally generated pilot through the channel estimate to obtain an interference estimate. The accuracy of the interference estimate may be dependent on the accuracy of the channel estimate, which may be better for a strong cell and/or after canceling interference from a strong cell.

[0050] An interference canceller 618a may receive the input samples and the estimated interference for each selected cell from interference estimator 616a. Interference canceller 618a may subtract the estimated interference for each selected cell from the input samples and may provide interference-canceled samples to the second stage 610b.

[0051] Second stage 610b includes a pilot detector 612b, a sorter 614b, an interference estimator 616b, and an interference canceller 618b that may operate on the interference-canceled samples in similar manner as the corresponding units in the first stage 610a. Pilot detector 612b may detect for pilots (e.g., low reuse pilots) from cells not detected or not canceled in the first stage 610a. Sorter 614b may select one or more detected cells for interference cancellation. Interference estimator 616b may estimate the interference due to each selected cell. Interference canceller 618b may cancel the estimated interference for each selected cell from the interference-canceled samples and may provide new interference-canceled samples to the next stage.

[0052] In general, pilot processor 584 may include any number of stages 610 and may operate in various manners. In one design, pilot processor 584 may perform successive detection and cancellation (SDC), which may be one interference cancellation scheme. With SDC, pilot processor 584 may sort the energies of all detected cells in each stage and may select the strongest detected cell for interference cancellation in that stage. Detection performance may improve by canceling the interference from the strongest cell in each stage and then processing the interference-canceled samples in the next stage. This may result in a more accurate estimate of the interference from the strongest cell detected in the next stage based on the interference-canceled samples having low interference from the strongest cell detected in each prior stage.

[0053] In another design, pilot processor 584 may perform interference cancellation for all detected cells in each stage. For each stage, pilot processor 584 may estimate the

interference due to each detected cell in that stage, cancel the interference due to all detected cells, and provide interference-canceled samples to the next stage. In yet another design, pilot processor 584 may perform interference cancellation for a predetermined number of strongest detected cells in each stage. In yet another design, pilot processor 584 may perform interference cancellation for all detected cells with energies exceeding a threshold in each stage. The threshold may be a fixed value that can provide good performance. The threshold may also be a configurable value, which may be set to a particular percentage of the total received energy of the UE. Pilot processor 584 may also perform interference cancellation in other manners.

[0054] Pilot processor 584 may perform pilot detection and interference cancellation in multiple stages, e.g., as shown in FIG. 6. Pilot processor 584 may provide search results for one or more detected cells in each stage and may also cancel the interference from one or more selected cells in each stage. Pilot processor 584 may repeat the pilot detection and interference cancellation until a termination condition is encountered. This termination condition may occur when a target number of cells have been detected, when all cells in a list of potential cells have been detected, when pilot processor 584 cannot detect any more cells, etc.

[0055] Detection performance with the use of low reuse pilots and/or interference cancellation was ascertained via computer simulation. The computer simulation models a cellular network with 37 base stations, with each base station having three cells, and each cell having a radius of 750 meters. In the simulation, each cell transmits a common pilot with a reuse factor of one ($M = 1$) and a low reuse pilot with a reuse factor of greater than one ($M > 1$). The common pilot is thus transmitted without multiplexing, and the low reuse pilot is transmitted with multiplexing. A number of UEs are randomly placed throughout the center cell in the cellular network. Each UE can detect for the common pilots or the low reuse pilots with or without interference cancellation.

[0056] FIG. 7A shows detection performance for the common pilots ($M = 1$) without interference cancellation at UEs in a given cell x . The coverage of cell x is represented by a hexagonal shape 710, which is a rough approximation of an antenna pattern for cell x . Cell x is located at a longitude of 0 meter and a latitude of 0 meter, i.e., in the middle of the left vertical axis. UEs are placed at randomly selected locations throughout cell x . Detection performance is quantified by the number of cells that the

UEs can detect based on the common pilots without interference cancellation. In particular, a value of k at a given location in FIG. 7A indicates that a UE at that location can detect k cells, where k may be any integer value.

[0057] As shown in FIG. 7A, the hearability of the common pilots without interference cancellation is generally poor. UEs located near the middle of cell x can detect only one or few cells due to strong interference from cell x . UEs located at the edges of cell x may be able to detect more cells due to less interference from cell x . The detection performance in FIG. 7A may be typical for most cellular networks with a reuse factor of one.

[0058] FIG. 7B shows detection performance for the low reuse pilots with a reuse factor of $M = 4$ and no interference cancellation at the UEs in cell x . As shown in FIG. 7B, the hearability of the low reuse pilots without interference cancellation is improved over the hearability of the common pilots in FIG. 7A. UEs located throughout cell x can detect nine or more cells in most cases. The improvement in hearability and the number of detected cells is not dependent on the UE locations since the interference from cell x is eliminated on resources (e.g., HDP slots or PA-RS resource elements) reserved for low reuse pilots but not used by cell x for its low reuse pilot.

[0059] FIG. 7C shows detection performance for the common pilots ($M = 1$) with interference cancellation at the UEs in cell x . As shown in FIG. 7C, the hearability of the common pilots with interference cancellation is improved over the hearability of the common pilots without interference cancellation in FIG. 7A. UEs located throughout cell x can detect more cells with interference cancellation. UEs located at the edges of cell x can generally detect more cells than UEs located near the middle of cell x due to less interference from cell x . The hearability with interference cancellation may be better than the hearability with the low reuse pilots, except at locations close to cell x transmitter.

[0060] FIG. 7D shows detection performance for the low reuse pilots with a reuse factor of $M = 4$ and interference cancellation at the UEs in cell x . As shown in FIG. 7D, the hearability of the low reuse pilots with interference cancellation is much improved over both (i) the hearability of the low reuse pilots without interference cancellation in FIG. 7B and (ii) the hearability of the common pilots with interference cancellation in FIG. 7C. UEs located throughout cell x can detect more cells based on the low reuse pilots with interference cancellation. Furthermore, the improvement in

hearability and the number of detected cells is generally not dependent on the UE locations.

[0061] FIG. 8 shows CDF of the number of detected cells for the four configurations shown in FIGS. 7A to 7D. The horizontal axis represents the number of detected cells, and the vertical axis represents CDF. A plot 810 shows the CDF of the number of detected cells for the common pilots without interference cancellation, which correspond to the configuration in FIG. 7A. A plot 820 shows the CDF of the number of detected cells for the low reuse pilots with $M = 4$ and no interference cancellation, which correspond to the configuration in FIG. 7B. A plot 830 shows the CDF of the number of detected cells for the common pilots with interference cancellation, which correspond to the configuration in FIG. 7C. A plot 840 shows the CDF of the number of detected cells for the low reuse pilots with $M = 4$ and interference cancellation, which correspond to the configuration in FIG. 7D. As shown in FIG. 8, the number of detected cells may greatly improve with the use of the low reuse pilots and/or interference cancellation.

[0062] In general, detection performance may be improved by using multiplexing with a higher reuse factor. Progressively higher reuse factor may result in progressively greater hearability but may also require more overhead for the low reuse pilots. A higher reuse factor may also result in a longer time to detect for the low reuse pilots and may further result in a longer delay to obtain a location estimate based on the detected low reuse pilots. Multiplexing may be more effective in terms of improving hearability at locations with a strong dominant pilot, e.g., close to a cell transmitter. Multiplexing may also result in more uniform hearability throughout the cell, e.g., as shown in FIG. 7B.

[0063] Detection performance may also be improved by using interference cancellation, which may be applicable for both the common pilots and the low reuse pilots. Interference cancellation can provide good detection performance even with a small reuse factor. It can be shown that detection performance for the low reuse pilots with $M = 4$ and interference cancellation is better than detection performance for the low reuse pilots with $M = 8$ and no interference cancellation. Interference cancellation may thus be used to improve detection performance and/or reduce the reuse factor M .

[0064] The techniques described herein may be used for various applications such as positioning of UEs. A UE may detect for pilots (e.g., low reuse pilots) from different

cells with interference cancellation to increase the number of cells that can be detected. The UE may obtain a time measurement (e.g., a time of arrival (TOA) measurement) based on the pilot from each detected cell. A location estimate for the UE may be derived based on the time measurements for the detected cells and their known locations using trilateration. The accuracy of the location estimate may improve and the location error may reduce with more detected cells.

[0065] FIG. 9 shows CDF of location error for a location estimate obtained with the four configurations shown in FIGS. 7A to 7D. The horizontal axis represents location error in units of meters, and the vertical axis represents CDF. A plot 910 shows the CDF of location error with the common pilots and no interference cancellation. A plot 920 shows the CDF of location error with the low reuse pilots with $M = 4$ and no interference cancellation. A plot 930 shows the CDF of location error with the common pilots and interference cancellation. A plot 940 shows the CDF of location error with the low reuse pilots with $M = 4$ and interference cancellation. As shown in FIG. 9, the location error may greatly reduce with the use of the low reuse pilots and/or interference cancellation.

[0066] As shown in FIGS. 7A to 9, interference cancellation may reduce the adverse impact of the near-far effect by canceling interference from strong cells to improve the hearability of weaker cells. Low reuse pilots with a reuse factor of greater than one may improve hearability in a uniform manner across a cell. The joint use of the low reuse pilots and interference cancellation may significantly improve detection performance. For a given detection performance, the reuse factor for the low reuse pilots may be reduced by employing interference cancellation. The smaller reuse factor may reduce overhead for the low reuse pilots, enable faster detection of the low reuse pilots from different cells, and reduce delay in obtaining a location estimate for a UE, all of which may be highly desirable. Furthermore, a more accurate location estimate may be obtained with more detected cells due to the use of the low reuse pilots and/or interference cancellation.

[0067] FIG. 10 shows a design of a process 1000 for performing cell detection by a UE. The UE may obtain a received signal comprising pilots transmitted by a plurality of cells in a wireless network (block 1012). The UE may process the received signal with interference cancellation to detect for the pilots from the plurality of cells (block 1014). The interference cancellation may improve the number of detected cells. In one

design, the pilots may comprise common pilots transmitted by the plurality of cells with a reuse factor of one. In another design, the pilots may comprise low reuse pilots transmitted by the plurality of cells with a reuse factor greater than one. Each cell may transmit its low reuse pilot on a subset of time slots available for transmitting the low reuse pilots (e.g., as shown in FIG. 3), or on a subset of subcarriers available for transmitting the low reuse pilots (e.g., as shown in FIG. 4), or on other resources available for transmitting the low reuse pilots.

[0068] FIG. 11 shows a design of block 1014 in FIG. 10, which implements successive detection and cancellation (SDC) for interference cancellation. The UE may process the received signal to detect for at least one pilot from at least one cell (block 1112). The UE may identify a strongest cell among the at least one cell (block 1114). The UE may then estimate the interference due to a pilot from the strongest cell (block 1116). The UE may cancel the estimated interference from the received signal to obtain an interference-canceled signal (block 1118). The UE may then process the interference-canceled signal to detect for at least one additional pilot from at least one additional cell (block 1120). The UE may repeat blocks 1114 to 1120 for any number of cells.

[0069] In another design of block 1014 in FIG. 10, the UE may perform pilot detection and interference cancellation in multiple stages, e.g., as shown in FIG. 6. For each stage, the UE may detect for one or more pilots from one or more cells and may select at least one cell for interference cancellation from among the one or more detected cells. The selected cell(s) may be the strongest cell or may be determined as described above. The UE may cancel the interference due to the at least one selected cell. For each selected cell, the UE may derive a channel estimate for the selected cell after canceling the interference from prior selected cells, generate a pilot for the selected cell, estimate the interference due to the selected cell based on the generated pilot and the channel estimate for the selected cell, and cancel the estimated interference. The UE may terminate the pilot detection and interference cancellation when no more pilots can be detected, or when a list of cells have been detected, or when a predetermined number of cells have been detected, or when some other termination is countered.

[0070] Referring back to FIG. 10, in one design, the UE may obtain time measurements for multiple detected cells based on the pilots from these cells (block 1016). The UE may then obtain a location estimate for itself based on the time

measurements for the multiple detected cells (block 1018). The UE may compute the location estimate based on the time measurements and the known locations of the detected cells, e.g., using trilateration. Alternatively, the UE may send the time measurements to the network, which may compute the location estimate for the UE. In another design, the UE may identify the multiple detected cells and may obtain a location estimate for itself based on the identities of the detected cells, e.g., using an enhanced cell ID positioning method. For all designs, the location estimate may have improved accuracy due to the higher number of detected cells with interference cancellation.

[0071] FIG. 12 shows a design of an apparatus 1200 for performing cell detection. Apparatus 1200 includes a module 1212 to obtain a received signal comprising pilots transmitted by a plurality of cells in a wireless network, a module 1214 to process the received signal with interference cancellation to detect for the pilots from the plurality of cells, a module 1216 to obtain time measurements for multiple detected cells based on the pilots from the detected cells, and a module 1218 to obtain a location estimate for a UE based on the time measurements for the detected cells.

[0072] The modules in FIG. 12 may comprise processors, electronics devices, hardware devices, electronics components, logical circuits, memories, software codes, firmware codes, etc., or any combination thereof.

[0073] Those of skill in the art would understand that information and signals may be represented using any of a variety of different technologies and techniques. For example, data, instructions, commands, information, signals, bits, symbols, and chips that may be referenced throughout the above description may be represented by voltages, currents, electromagnetic waves, magnetic fields or particles, optical fields or particles, or any combination thereof.

[0074] Those of skill would further appreciate that the various illustrative logical blocks, modules, circuits, and algorithm steps described in connection with the disclosure herein may be implemented as electronic hardware, computer software, or combinations of both. To clearly illustrate this interchangeability of hardware and software, various illustrative components, blocks, modules, circuits, and steps have been described above generally in terms of their functionality. Whether such functionality is implemented as hardware or software depends upon the particular application and design constraints imposed on the overall system. Skilled artisans may implement the

described functionality in varying ways for each particular application, but such implementation decisions should not be interpreted as causing a departure from the scope of the present disclosure.

[0075] The various illustrative logical blocks, modules, and circuits described in connection with the disclosure herein may be implemented or performed with a general-purpose processor, a digital signal processor (DSP), an application specific integrated circuit (ASIC), a field programmable gate array (FPGA) or other programmable logic device, discrete gate or transistor logic, discrete hardware components, or any combination thereof designed to perform the functions described herein. A general-purpose processor may be a microprocessor, but in the alternative, the processor may be any conventional processor, controller, microcontroller, or state machine. A processor may also be implemented as a combination of computing devices, e.g., a combination of a DSP and a microprocessor, a plurality of microprocessors, one or more microprocessors in conjunction with a DSP core, or any other such configuration.

[0076] The steps of a method or algorithm described in connection with the disclosure herein may be embodied directly in hardware, in a software module executed by a processor, or in a combination of the two. A software module may reside in RAM memory, flash memory, ROM memory, EPROM memory, EEPROM memory, registers, hard disk, a removable disk, a CD-ROM, or any other form of storage medium known in the art. An exemplary storage medium is coupled to the processor such that the processor can read information from, and write information to, the storage medium. In the alternative, the storage medium may be integral to the processor. The processor and the storage medium may reside in an ASIC. The ASIC may reside in a user terminal. In the alternative, the processor and the storage medium may reside as discrete components in a user terminal.

[0077] In one or more exemplary designs, the functions described may be implemented in hardware, software, firmware, or any combination thereof. If implemented in software, the functions may be stored on or transmitted over as one or more instructions or code on a computer-readable medium. Computer-readable media includes both computer storage media and communication media including any medium that facilitates transfer of a computer program from one place to another. A storage media may be any available media that can be accessed by a general purpose or special purpose computer. By way of example, and not limitation, such computer-readable

media can comprise RAM, ROM, EEPROM, CD-ROM or other optical disk storage, magnetic disk storage or other magnetic storage devices, or any other medium that can be used to carry or store desired program code means in the form of instructions or data structures and that can be accessed by a general-purpose or special-purpose computer, or a general-purpose or special-purpose processor. Also, any connection is properly termed a computer-readable medium. For example, if the software is transmitted from a website, server, or other remote source using a coaxial cable, fiber optic cable, twisted pair, digital subscriber line (DSL), or wireless technologies such as infrared, radio, and microwave, then the coaxial cable, fiber optic cable, twisted pair, DSL, or wireless technologies such as infrared, radio, and microwave are included in the definition of medium. Disk and disc, as used herein, includes compact disc (CD), laser disc, optical disc, digital versatile disc (DVD), floppy disk and blu-ray disc where *disks* usually reproduce data magnetically, while *discs* reproduce data optically with lasers. Combinations of the above should also be included within the scope of computer-readable media.

[0078] The previous description of the disclosure is provided to enable any person skilled in the art to make or use the disclosure. Various modifications to the disclosure will be readily apparent to those skilled in the art, and the generic principles defined herein may be applied to other variations without departing from the scope of the disclosure. Thus, the disclosure is not intended to be limited to the examples and designs described herein but is to be accorded the widest scope consistent with the principles and novel features disclosed herein.

[0079] **WHAT IS CLAIMED IS:**

74769-3285

21

CLAIMS:

1. A method of detecting for cells in a wireless communication network,
comprising:
 - 5 obtaining a received signal comprising pilots transmitted by a plurality of cells
in the wireless network; and
 - processing the received signal with interference cancellation to detect for the
pilots from the plurality of cells, the interference cancellation improving the number of
detected cells, wherein the processing of the received signal comprises performing pilot
detection and interference cancellation of the received signal in multiple stages, and for each
10 stage:
 - detecting one or more of the pilots in the received signal from one or more of
the plurality of cells;
 - selecting at least one cell for interference cancellation from the one or more of
the plurality of cells based in part on the one or more pilots;
 - 15 deriving a channel estimate for the selected cell after canceling interference
from prior selected cells from the received signal;
 - generating a pilot for the selected cell;
 - estimating interference due to the selected cell based on the generated pilot and
the channel estimate for the selected cell; and
 - 20 canceling interference due to the selected cell from the received signal based
on the estimated interference.
2. The method of claim 1, wherein the detected one or more cells at each stage
include a strongest cell, and the canceling the interference from the received signal at each
stage yields an interference-canceled signal for a next stage.

74769-3285

22

3. The method of claim 1, wherein the processing the received signal with interference cancellation comprises terminating the pilot detection and interference cancellation after one of the multiple stages when no more pilots are detectable.
4. The method of claim 1, wherein the processing the received signal with
5 interference cancellation comprises terminating the pilot detection and interference cancellation after one of the multiple stages when all cells in a list of cells have been detected, or when a predetermined number of cells have been detected, or when a termination condition is encountered.
5. The method of claim 1, further comprising:
10 obtaining time measurements for the one or more cells based on the one or more pilots; and
obtaining a location estimate for a user equipment (UE) based on the time measurements for the one or more cells.
6. The method of claim 1, further comprising:
15 obtaining a location estimate for a user equipment (UE) based on identifying the one or more cells.
7. The method of claim 1, wherein the pilots comprise common pilots transmitted by the plurality of cells with a reuse factor of one.
8. The method of claim 1, wherein the pilots comprise low reuse pilots
20 transmitted by the plurality of cells with a reuse factor greater than one.
9. The method of claim 8, wherein each cell transmits a low reuse pilot on a subset of time slots available for transmitting the low reuse pilots.
10. The method of claim 8, wherein each cell transmits a low reuse pilot on a subset of subcarriers available for transmitting the low reuse pilots.

74769-3285

23

11. An apparatus for wireless communication, comprising:

means for obtaining a received signal comprising pilots transmitted by a plurality of cells in a wireless communication network; and

5 means for processing the received signal with interference cancellation to detect for the pilots from the plurality of cells, the interference cancellation improving the number of detected cells, including:

means for performing pilot detection and interference cancellation in multiple stages,

10 means for detecting one or more of the pilots in the received signal from one or more of the plurality of cells in each of the multiple stages,

means for selecting at least one cell from the one or more of the plurality of cells based in part on the one or more pilots in each of the multiple stages,

means for deriving a channel estimate for the selected cell after canceling interference from prior selected cells from the received signal in each of the multiple stages,

15 means for generating a pilot for the selected cell in each of the multiple stages,

means for estimating interference due to the selected cell based on the generated pilot and the channel estimate for the selected cell in each of the multiple stages, and

20 means for canceling interference due to the selected cell from the received signal based on the estimated interference in each of the multiple stages.

12. The apparatus of claim 11, wherein the one or more cells at each of the multiple stages include a strongest cell, and the means for canceling the interference from the received signal at each stage yields an interference-canceled signal for a next stage.

74769-3285

24

13. The apparatus of claim 11, further comprising means for obtaining a location estimate for a user equipment (UE) based on the means for identifying the one or more cells.

14. The apparatus of claim 11, further comprising:

5 means for obtaining time measurements for the one or more cells based on the one or more pilots; and

means for obtaining a location estimate for a user equipment (UE) based on the time measurements for the one or more cells.

15. An apparatus for wireless communication, comprising:

at least one processor configured to:

10 obtain a received signal comprising pilots transmitted by a plurality of cells in a wireless communication network; and

process the received signal to detect for the pilots from the plurality of cells at least in part by performing pilot detection and interference cancellation in multiple stages and, for each stage:

15 detecting one or more of the pilots in the received signal from one or more of the plurality of cells,

selecting at least one cell from the one or more of the plurality of cells based in part on the one or more pilots,

20 deriving a channel estimate for the selected cell after canceling interference from prior selected cells from the received signal,

generating a pilot for the selected cell,

estimating interference due to the selected cell based on the generated pilot and the channel estimate for the selected cell, and

74769-3285

25

canceling interference due to the selected cell from the received signal based on the estimated interference.

16. The apparatus of claim 15, wherein the one or more cells at each stage include a strongest cell, and the at least one processor performs interference cancellation from the
5 received signal at each stage to yield an interference-canceled signal for a next stage.

17. The apparatus of claim 15, wherein the at least one processor is configured to obtain a location estimate for a user equipment (UE) based on identifying the one or more cells.

18. The apparatus of claim 15, wherein the at least one processor is configured to
10 obtain time measurements for the one or more cells based on the one or more pilots, and to obtain a location estimate for a user equipment (UE) based on the time measurements for the one or more cells.

19. A computer program product comprising a non-transitory computer-readable storage medium having stored thereon computer-executable instructions that, when executed
15 by at least one computer, cause the at least one computer to:

obtain a received signal comprising pilots transmitted by a plurality of cells in a wireless communication network, and

process the received signal to detect for the pilots from the plurality of cells at least in part by performing pilot detection and interference cancellation in multiple stages and,
20 for each stage:

detecting one or more of the pilots from one or more cells,

selecting at least one cell for interference cancellation from among the one or more detected cells,

deriving a channel estimate for the selected cell after canceling interference
25 from prior selected cells from the received signal;

74769-3285

26

generating a pilot for the selected cell;

estimating interference due to the selected cell based on the generated pilot and the channel estimate for the selected cell; and

canceling interference due to the selected cell based on the estimated
5 interference.

20. The computer program product of claim 19, wherein the one or more cells at each stage include a strongest cell, and the at least one computer processing the received signal comprises performing the pilot detection and interference cancellation from the received signal at each stage yielding an interference-canceled signal for a next stage.

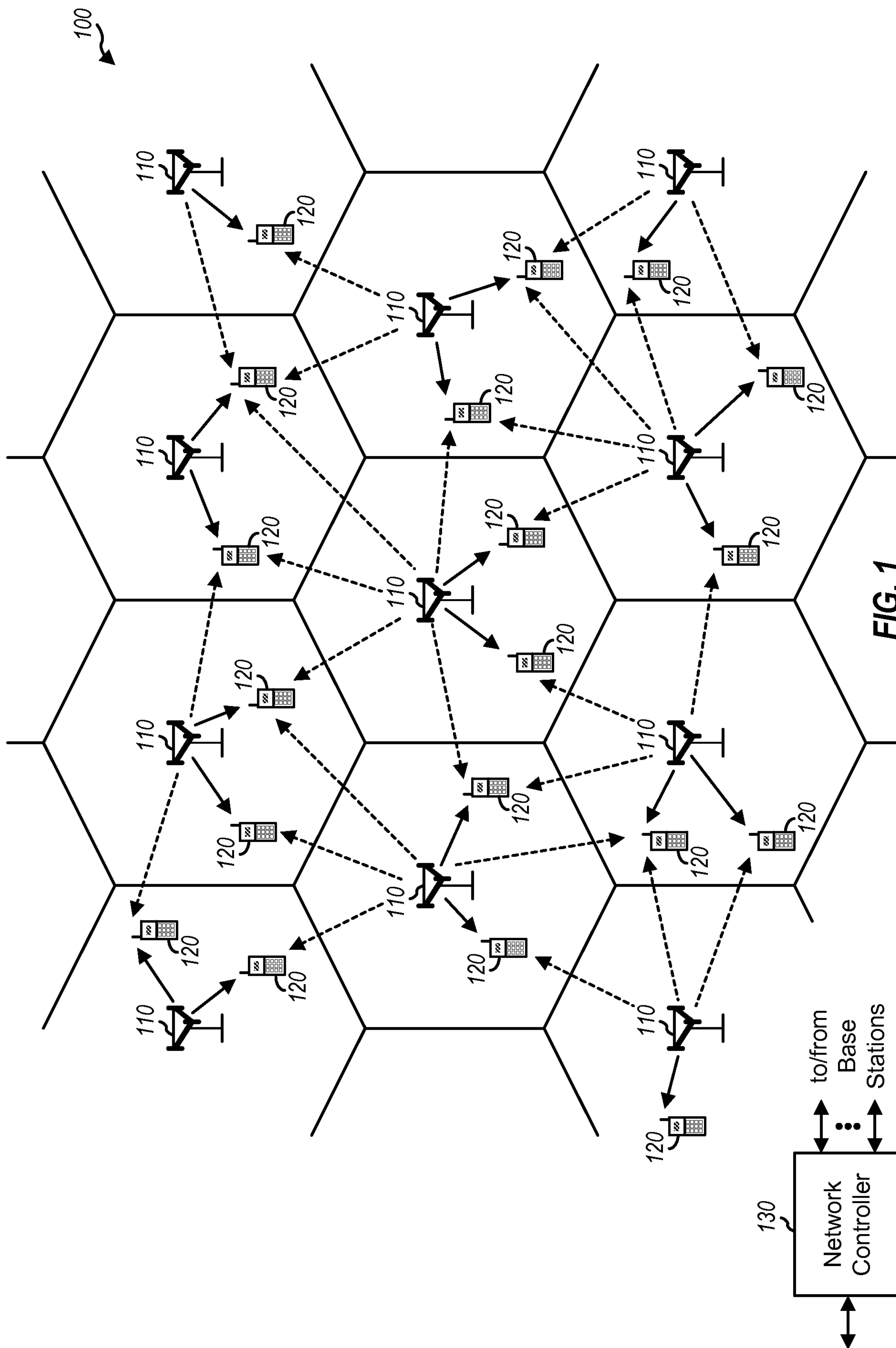

FIG. 1

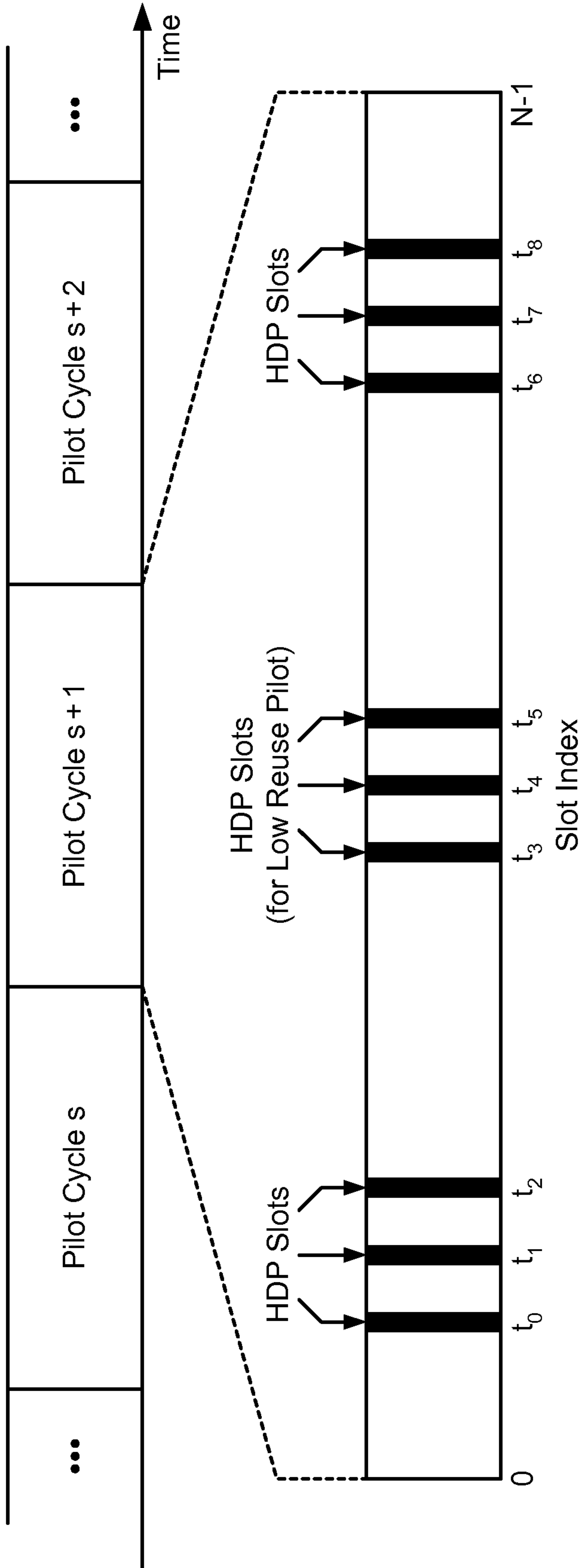

FIG. 2

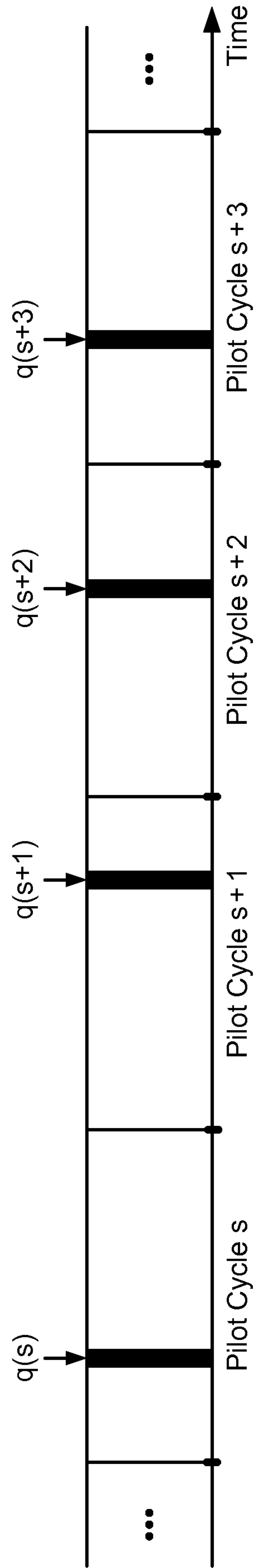

FIG. 3

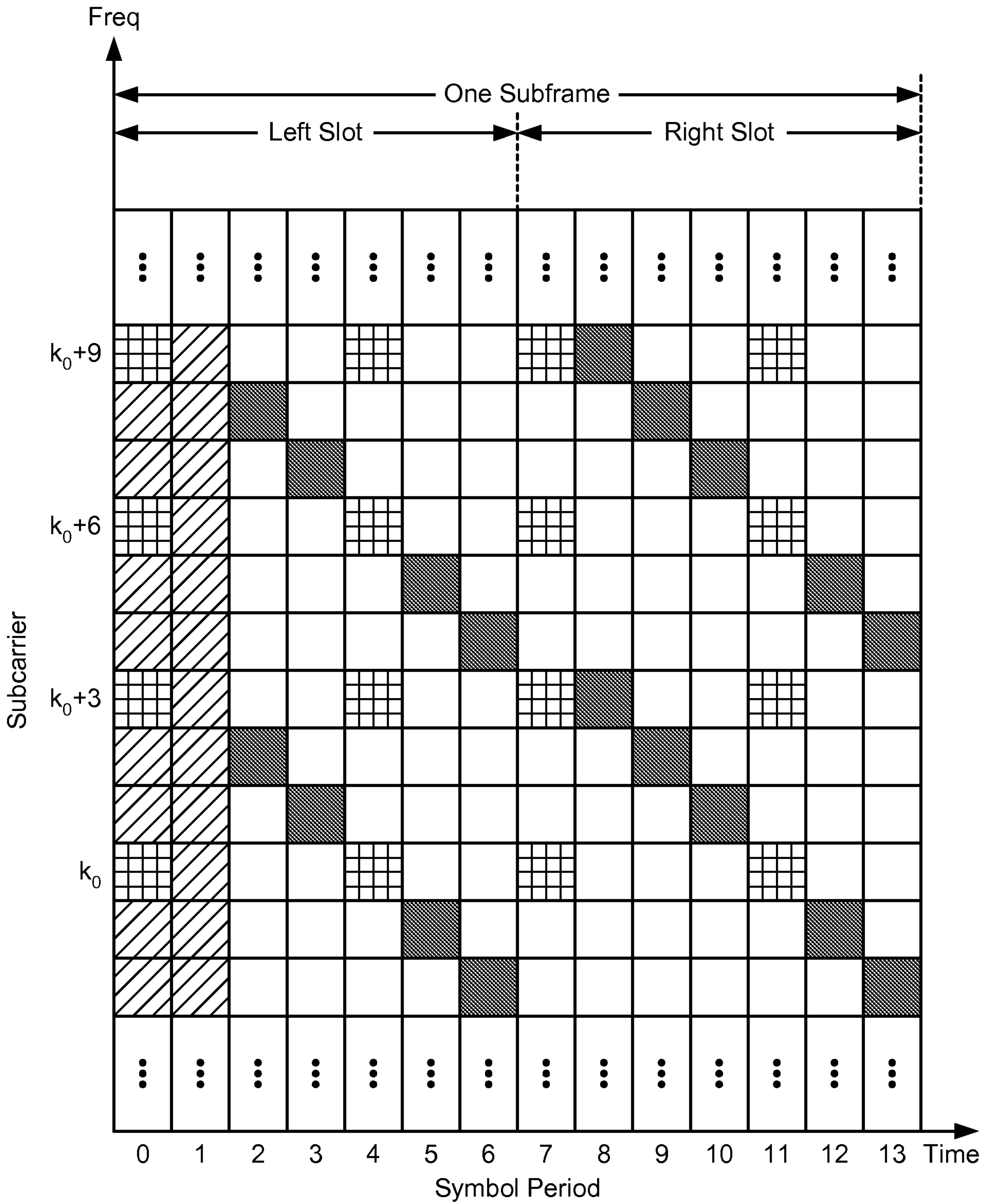
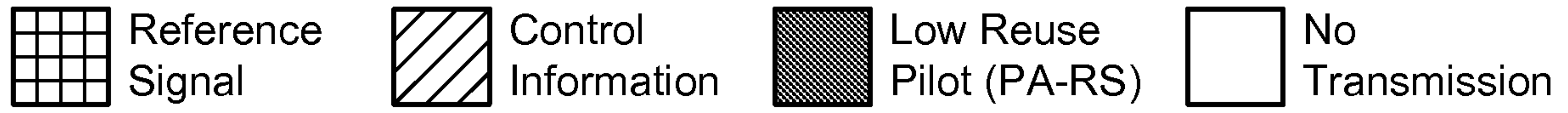

FIG. 4

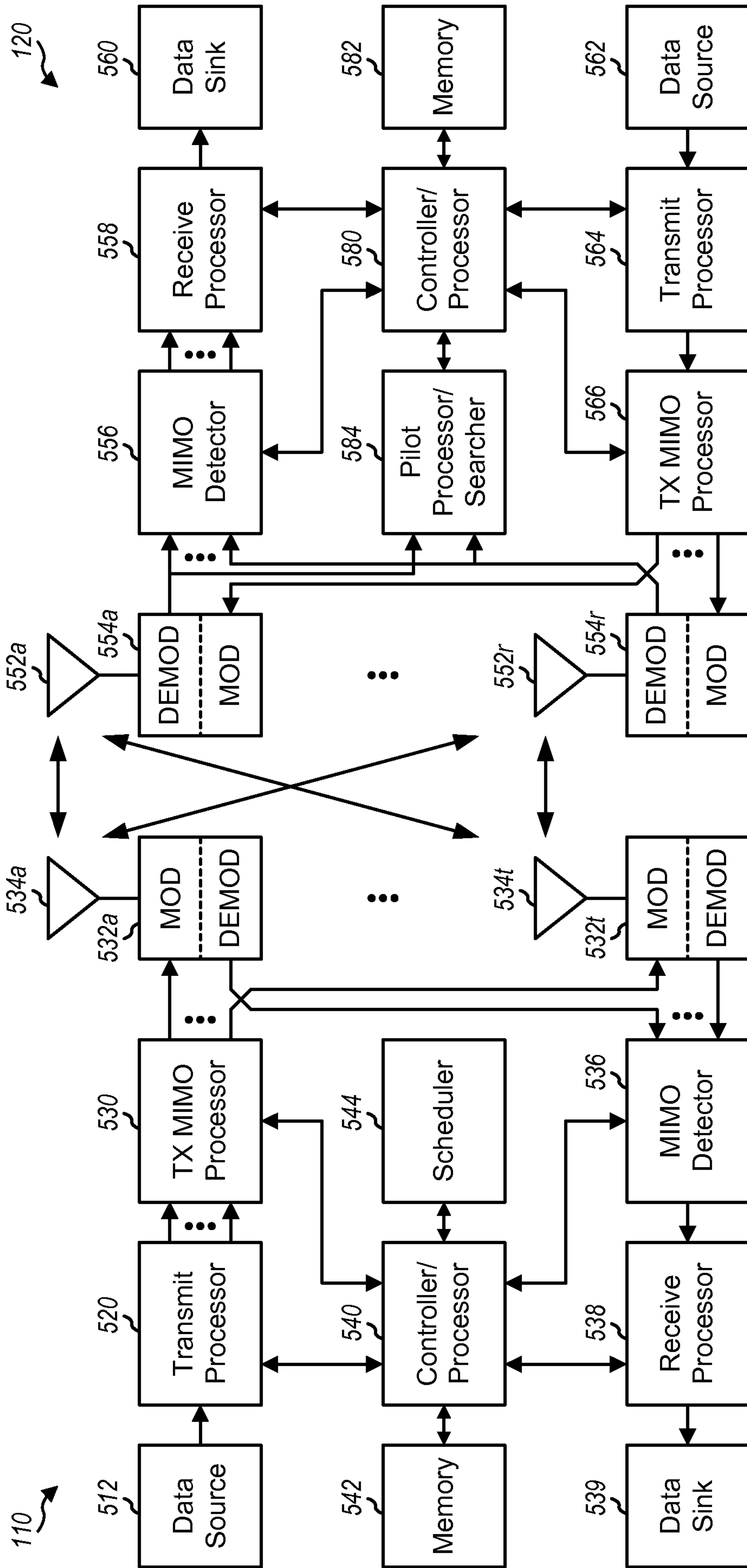

FIG. 5

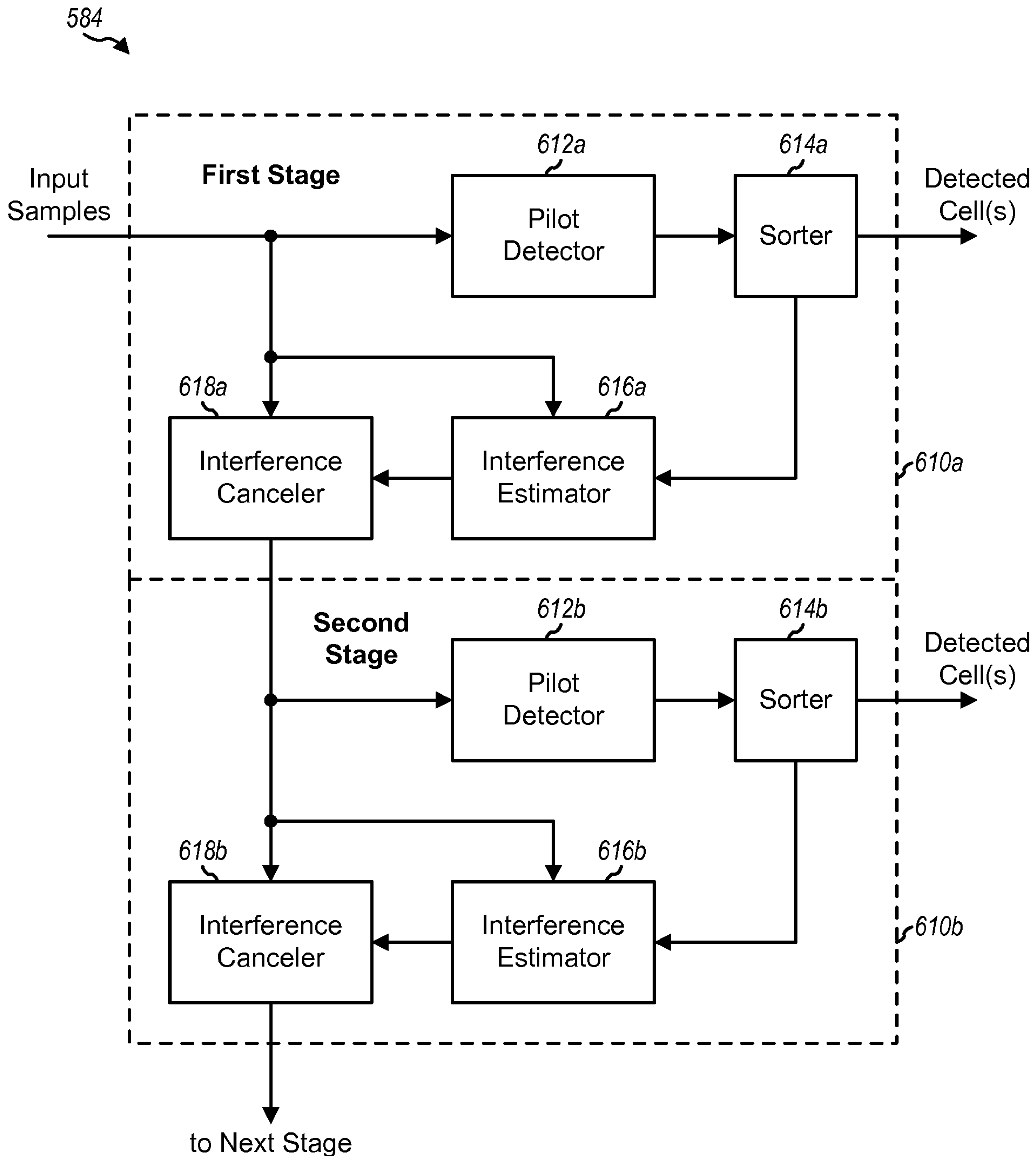

FIG. 6

6/9

Common Pilots without Interference Cancellation

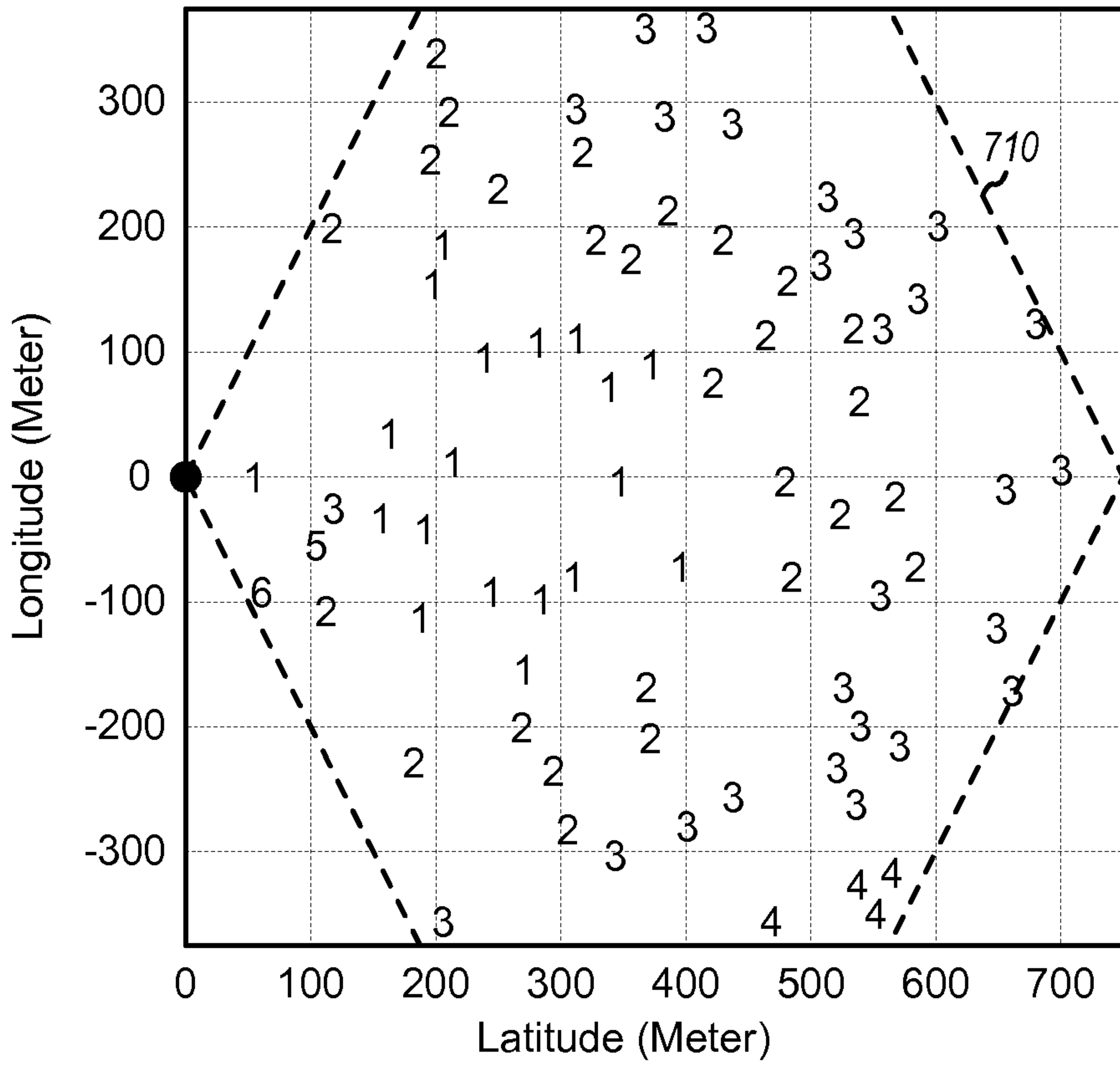

FIG. 7A

Low Reuse Pilots without Interference Cancellation

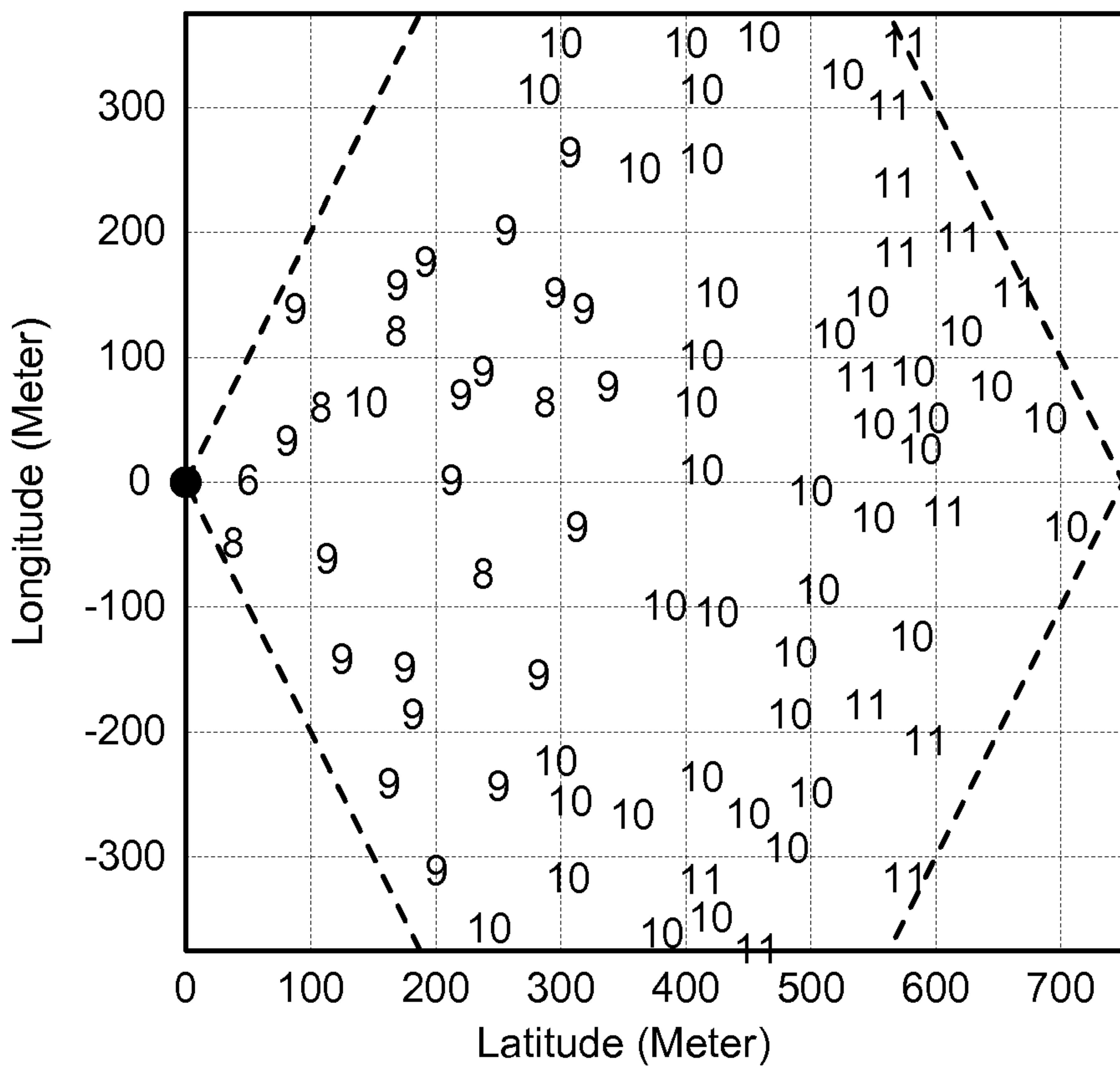

FIG. 7B

7/9

Common Pilots with Interference Cancellation

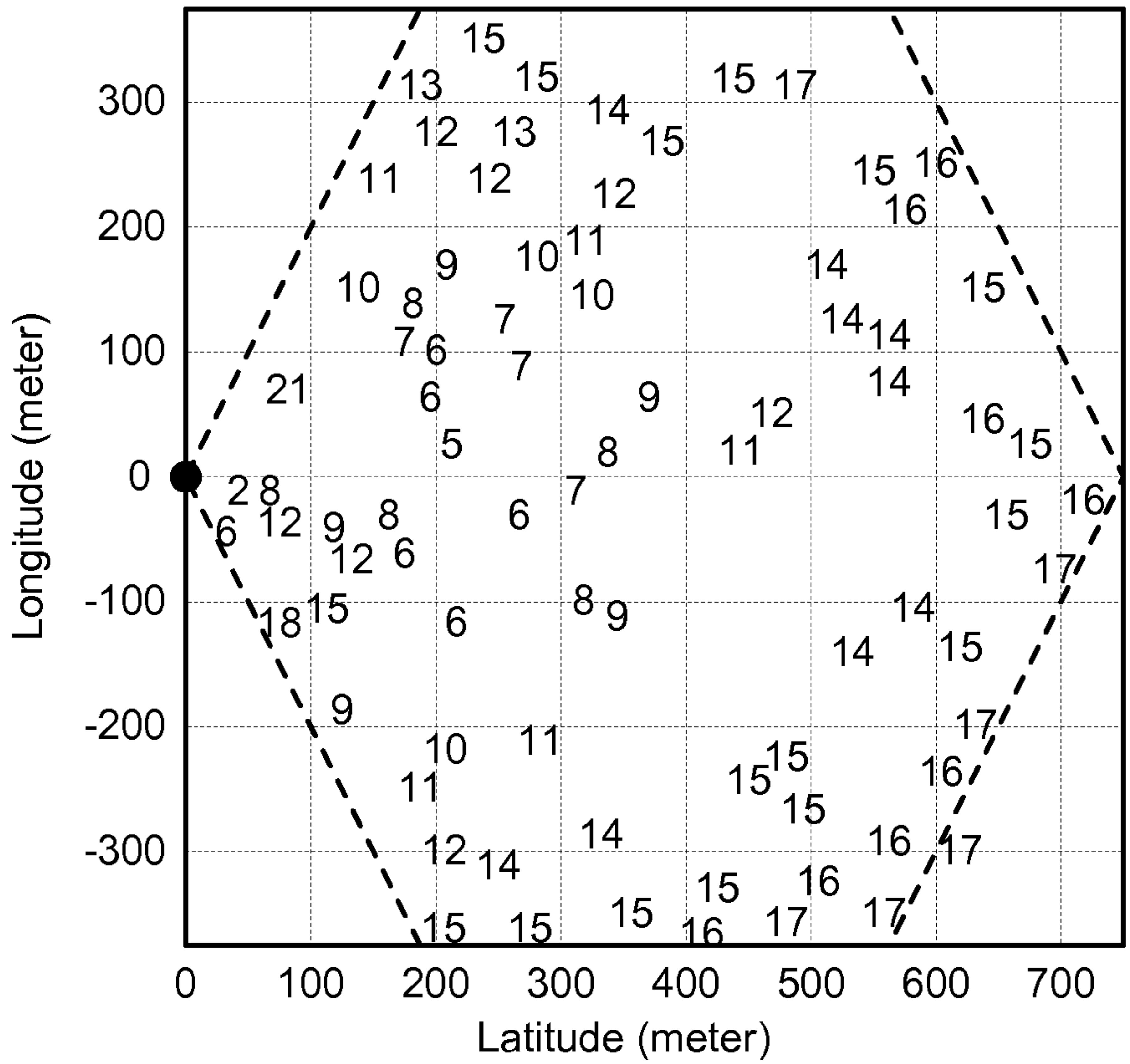

FIG. 7C

Low Reuse Pilots (M=4) with Interference Cancellation

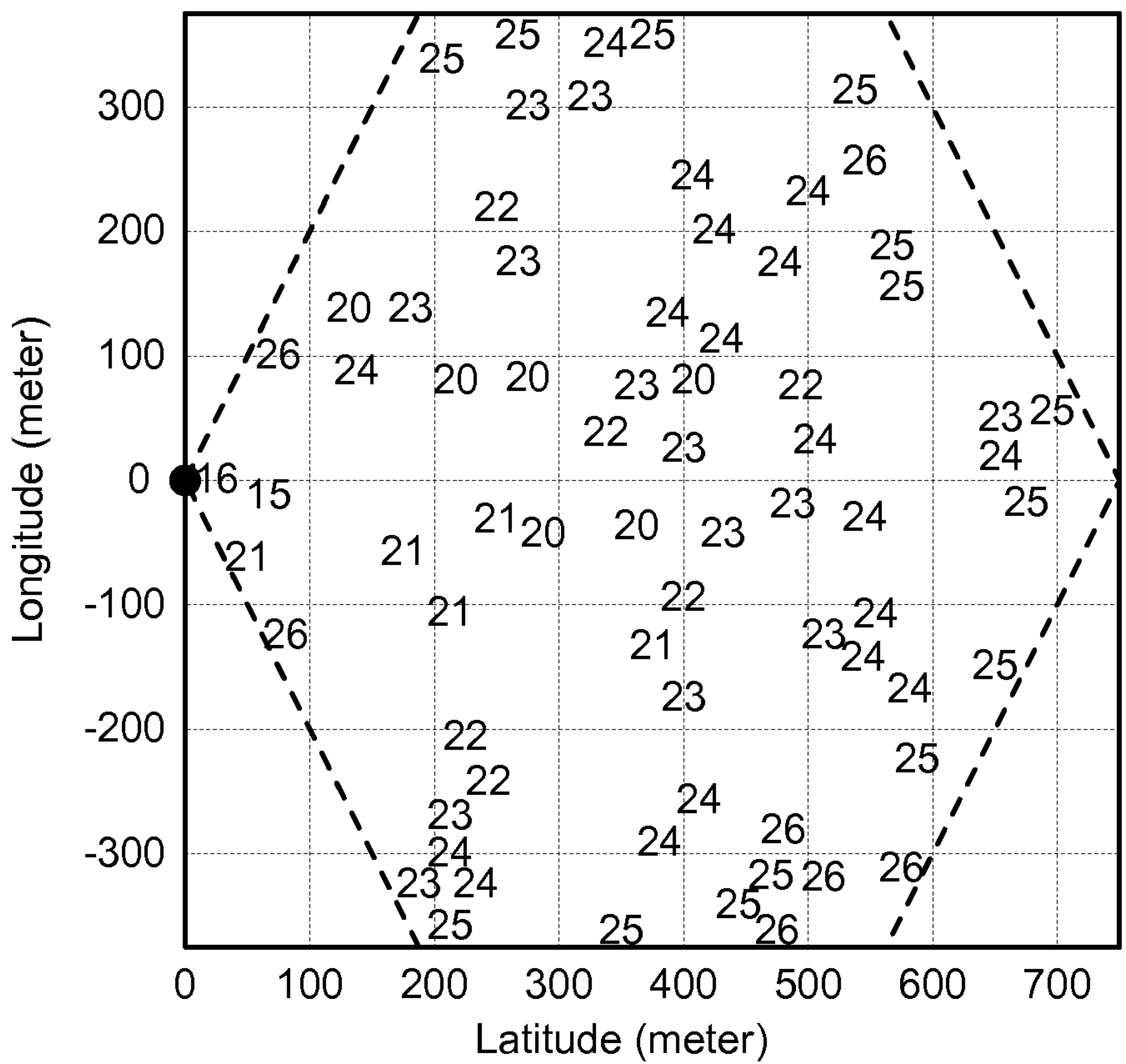
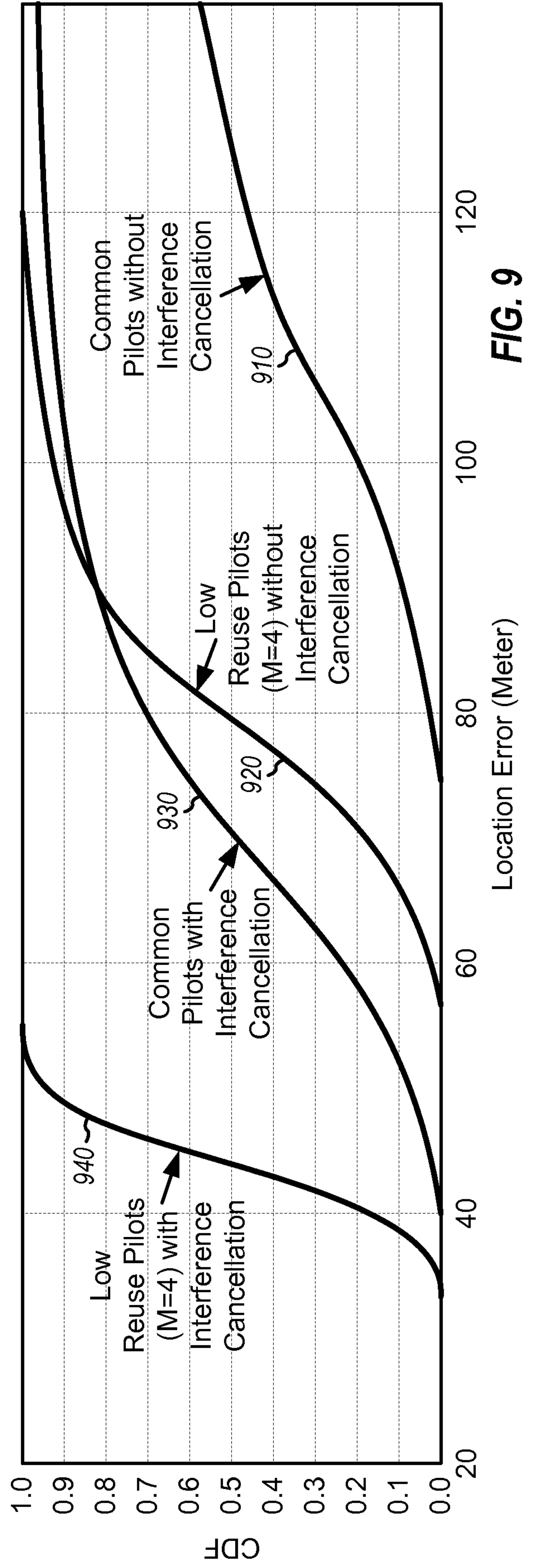
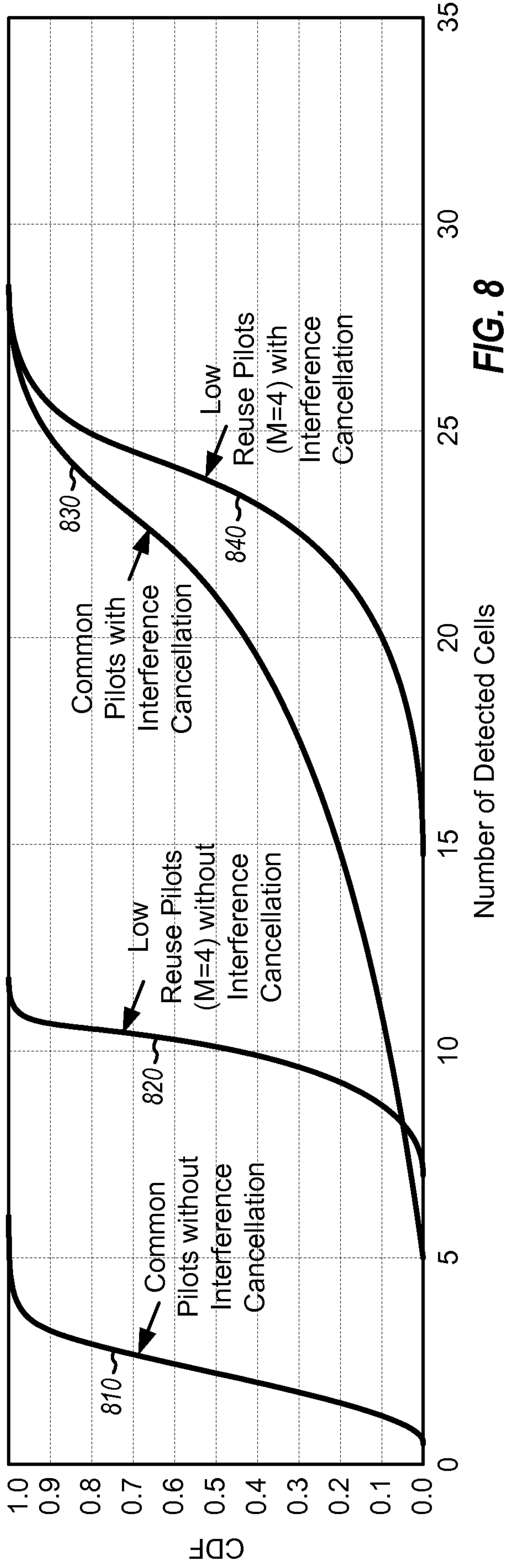

FIG. 7D



9/9

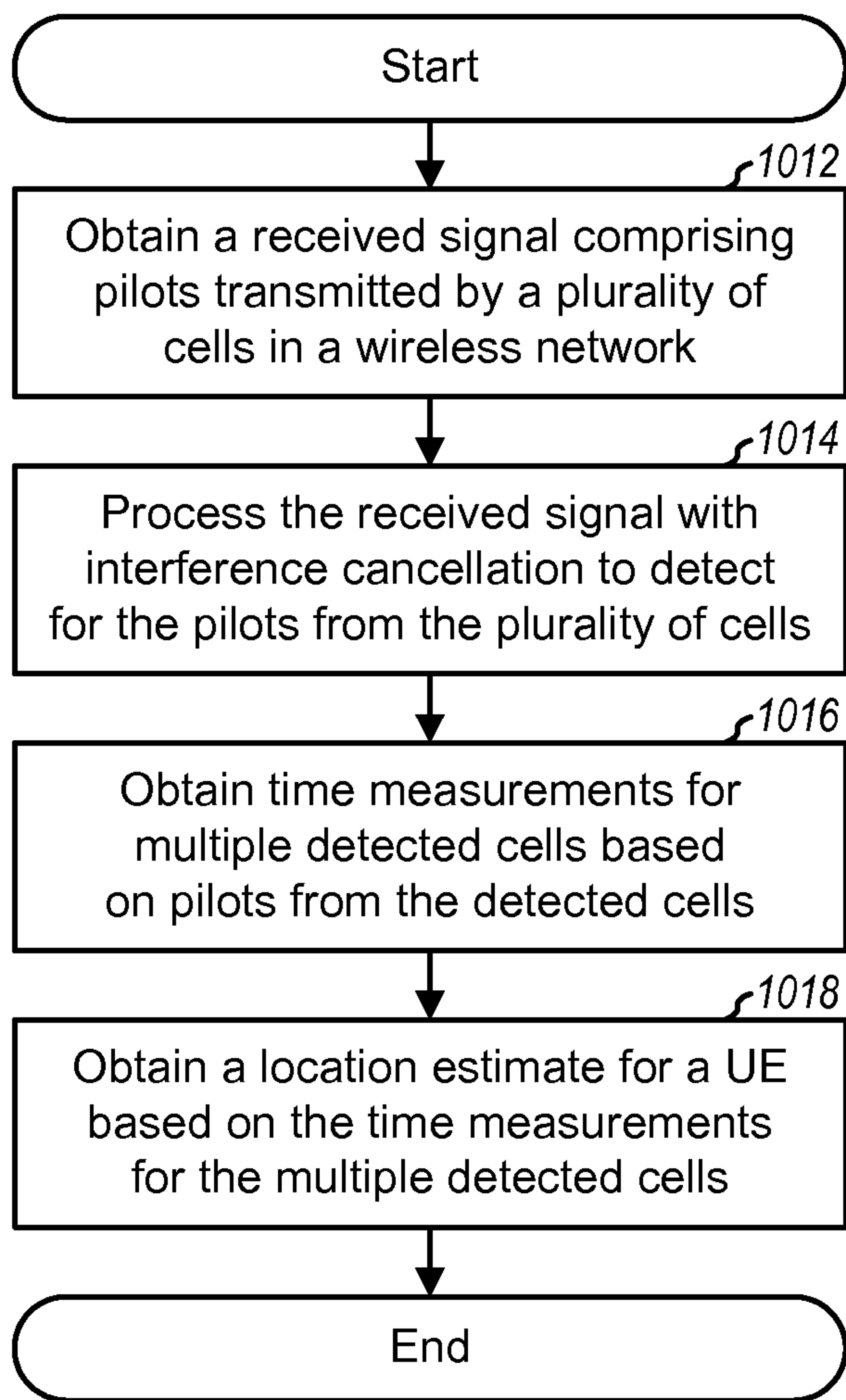

FIG. 10

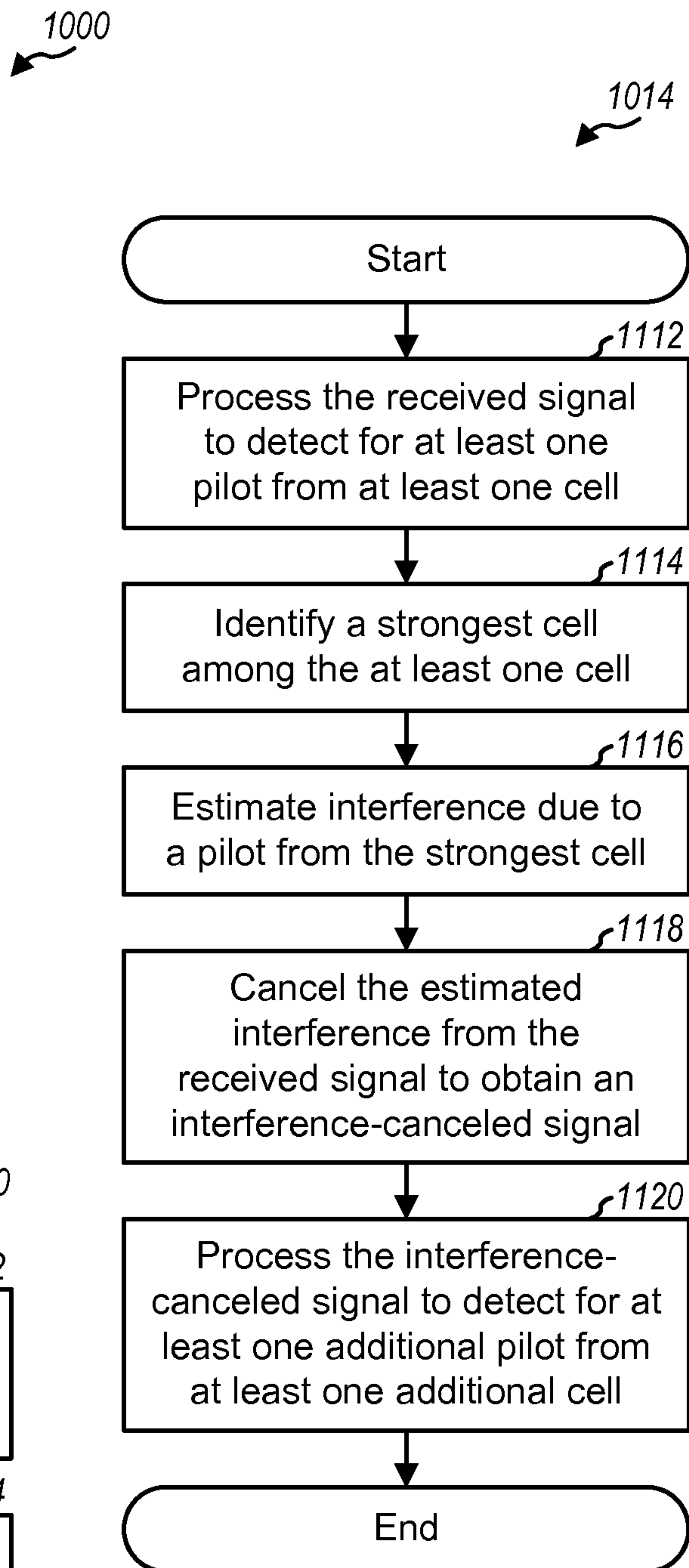

FIG. 11

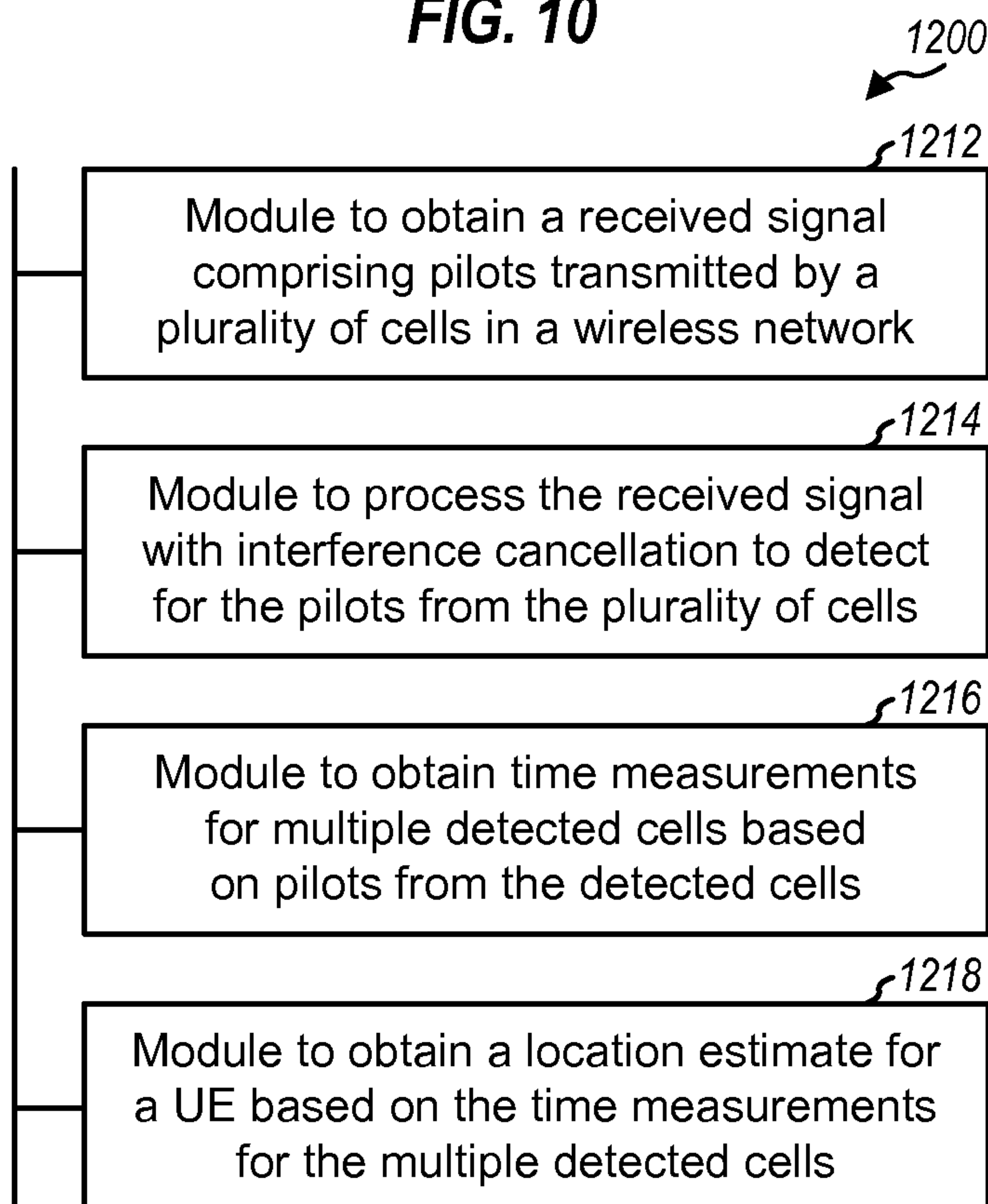

FIG. 12

