

(19)  
(12)

(KR)  
(Y1)

(51) 。 Int. Cl.7  
B08B 9/08

(45)  
(11)  
(24)

2004 02 18  
20-0342377  
2004 02 06

(21) 20-2003-0036858  
(22) 2003 11 26

(73) ( ) 124-1 가 105

(72) 1 285-4 106 1502

(74)

가 :

(54)

(OIL TANK CLEANING SYSTEM)

가

(12) (3) (12)가 (4) (11) (5) (1-1) (1) (2) (7)  
(12) (2) (12) (1) (12) (2) (1) (1)  
(2) (12) (12) (3) (4) (5)  
(1) 가

- 1
- 2
- 3
- 4

1-1 :

1 :

2 : (VACUUM TANK)

3 : (HEATER)

4 :

5 :

6 : (SOLENOID VALVE)

7 :

8 : (RELIEF VALVE)

9 :

10 :

11 :

B1 :

B2 :

B3 :

B4 :

B5 :



12) (12) (2) 2 (1) (B4) (7) (2) (11) ( )  
 (1) (2) (B2) (6) (9)  
 (12) (7) (12)  
 (2) (1) (1)  
 (12) (2) 4 (12) (B2) (SLUDGE)  
 (1) (11)  
 (2) 4 (2) (2)

(3) (11) (1-1) (4) (5) (2) (1) (2) (12) (12)  
 가 . , (2)

(57)

1. (1-1) (1) (2) (1)  
 (B1) (3), (4), 가 (8)  
 (9) (5), (6), (7) (2) (B3)  
 (B5) (6)(9) (B2) (10) (11) (12)  
 (B4)

1

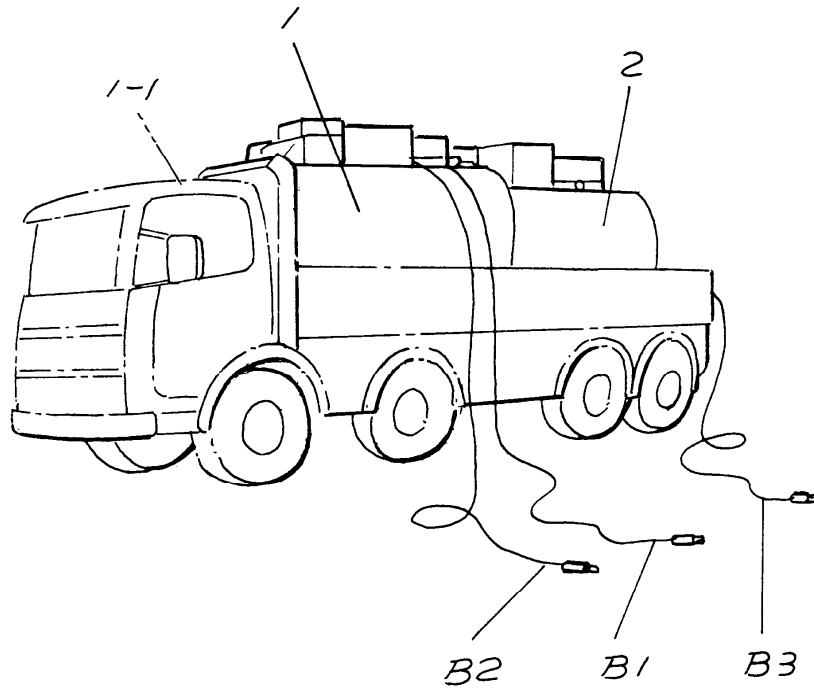

2

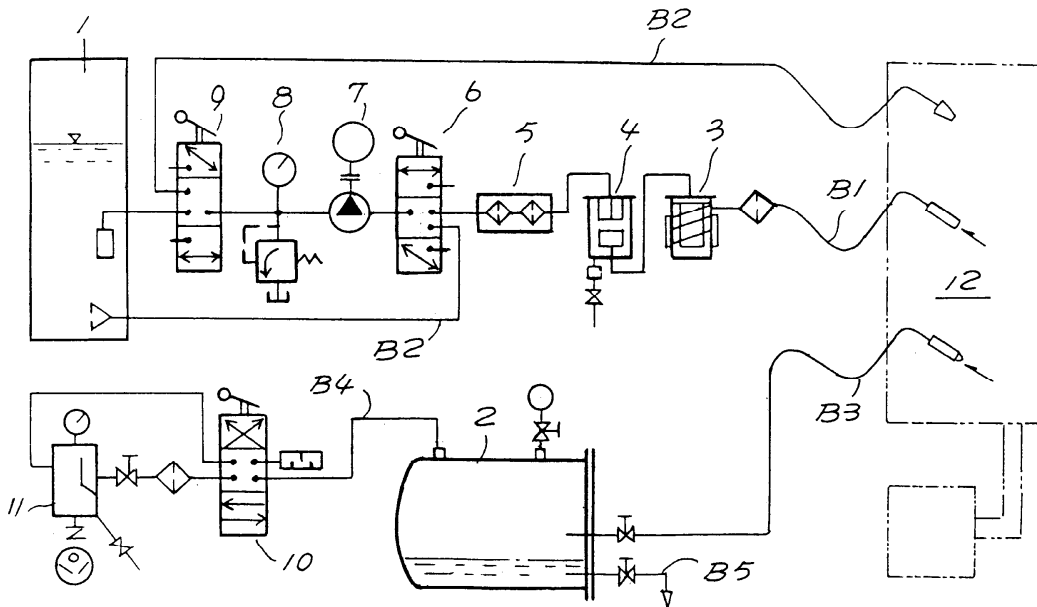

3

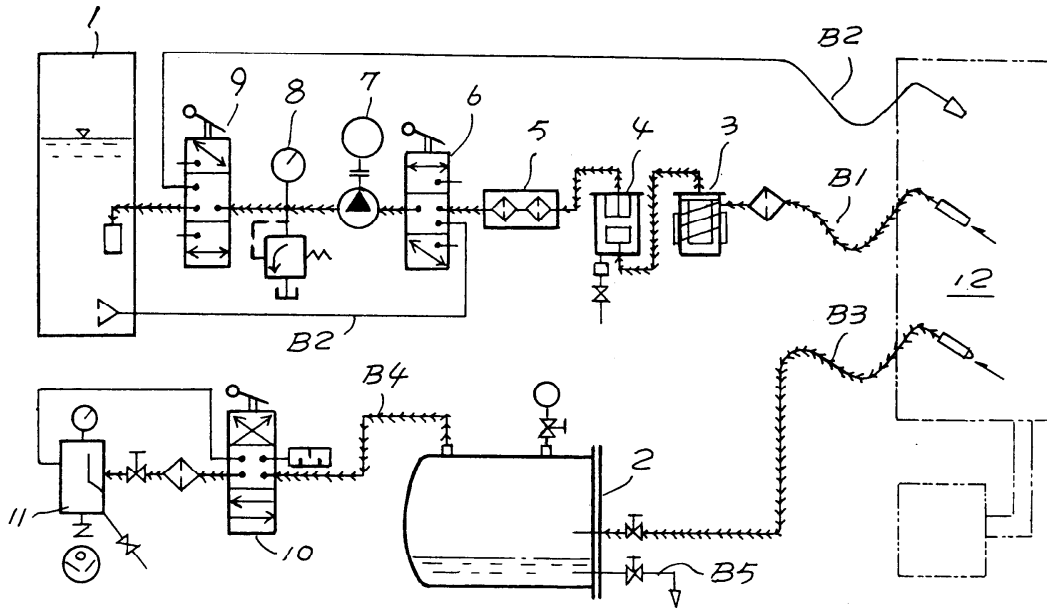

4

