

(No Model.)

A. J. GINTHER.
SELF ACTING WIND PROOF DAMPER.

No. 479,801.

Patented Aug. 2, 1892.

Fig. 1

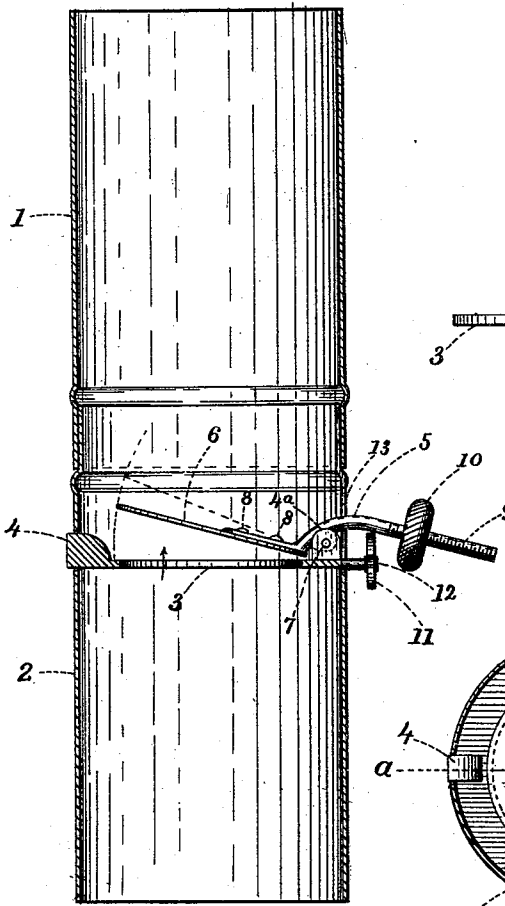

Fig. 2

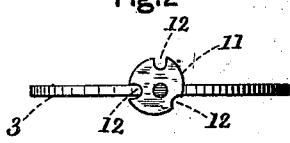
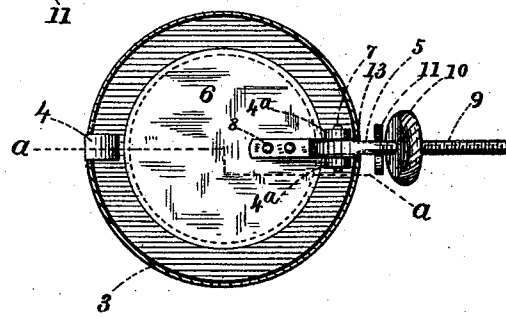

Fig. 3



Witnesses.

J. M. Caldwell.
Arthur J. Sangster.

Augustus J. Gintner, Inventor.
By James Sangster
Attorney.

UNITED STATES PATENT OFFICE.

AUGUSTUS J. GINTHER, OF BUFFALO, NEW YORK.

SELF-ACTING WIND-PROOF DAMPER.

SPECIFICATION forming part of Letters Patent No. 479,801, dated August 2, 1892.

Application filed November 30, 1891. Serial No. 413,467. (No model.)

To all whom it may concern:

Be it known that I, AUGUSTUS J. GINTHER, a citizen of the United States, residing in Buffalo, in the county of Erie and State of New York, have invented certain new and useful Improvements in Self-Acting Wind-Proof Dampers, of which the following is a specification.

It is well known that in some buildings the wind is liable to blow down through the chimney, and thereby fill the room with smoke.

The object of my invention is to provide the means whereby this objection may be avoided, and it will be fully and clearly hereinafter described and claimed, reference being had to the accompanying drawings, in which—

Figure 1 is a sectional elevation cutting vertically through a portion of the pipe in which the damper is placed in or about line *a a*, Fig. 3. Fig. 2 is an edge view of the damper-frame, showing a face view of the device for regulating the height the damper shall open, the damper being omitted. Fig. 3 is a plan view of the damper complete.

Referring to the drawings, 1 and 2 represent two joints of common sheet-iron stove-pipe, which are made in any well-known way and to which my improved damper is usually attached. The damper consists of a circular ring portion 3, having a lug 4 projecting out at one side and at the opposite side two upwardly-projecting lugs or ears 4^a, between which the handle 5 of the movable portion 6 of the damper is pivoted by a pin 7. The handle 5 is riveted to the portion 6 by rivets 8 and is provided with a screw portion 9, upon which a milled weight 10 is adapted to be screwed back and forth, so as to regulate the damper when required. This movable damper portion 6 is pivoted so as to swing easily on the pin 7, and the weight is adjusted on the arm 5, so that it will just overbalance the portion 6, thereby keeping the movable damper 6 substantially in the position shown in Fig. 1 until a slight pressure from the wind closes it.

To adjust the damper so as to open more or less, I employ a small thumb-piece 11, which is made to turn upon a small portion projecting from the back of the ring portion

3. The periphery of this thumb-piece 11 is provided with a series of notches 12. Each notch is located nearer and nearer to the center of the thumb-piece, as shown. 55

From the above it will be seen that the distance to which the damper moves may be varied, and there may be more or less than the number of notches 12 shown in the drawings.

Experience has shown me that the blowing of the wind down a chimney is but momentary—hardly long enough to interfere with the fire—and the moment it stops the damper instantly rises and allows the smoke to pass up, so that while the smoke and products of combustion are free at all times to pass upward while the damper is open it is never permitted to pass downward into the room, as the least pressure of air and smoke downward instantly closes the damper and keeps it closed until the pressure is released, which is generally within the fraction of a second, and when natural gas is used as fuel it prevents it from being blown out.

The damper is put into a pipe by slipping the lug 4 into a hole in one side of the pipe 2 and then moving the rear portion and handle down through a slot 13, cut in the pipe, until it lies horizontal, as shown in Fig. 1. The upper joint of the pipe 1 is then slipped on, substantially as shown in Fig. 1. 80

I claim as my invention—

In a stovepipe-damper, the combination of a supporting-ring provided with a projecting lug 4 for the purpose described, two upwardly-projecting lugs or ears 4^a on the same face at the opposite side of the ring, a projecting piece from the periphery of the ring back of the ears or lugs 4^a, upon which is pivoted an adjusting thumb-piece 11, having a series of notches of varying distances from the center for adjusting the height the damper shall rise, a damper 6, having a curved handle 5 pivoted between the ears 4^a and provided with a screw portion, upon which is mounted an adjusting-weight adapted to screw back and forth on said handle, substantially as and for the purposes described. 95

AUGUSTUS J. GINTHER.

Witnesses:

ARTHUR J. SANGSTER,
JAMES SANGSTER.