



US 20080128417A1

(19) **United States**

(12) **Patent Application Publication**  
Smith et al.

(10) **Pub. No.: US 2008/0128417 A1**

(43) **Pub. Date: Jun. 5, 2008**

(54) **RECLOSABLE CONTAINER LID**

**Related U.S. Application Data**

(75) Inventors: **Stephen Alan Smith**, Naperville, IL (US); **Warren Giles Wiedmeyer**, Slinger, WI (US); **Richard Matthew Chin**, Lincolnwood, IL (US); **John Stewart Gitschlag**, Chicago, IL (US); **David Raymond Langelan**, Oak Park, IL (US); **Kevin Ray Smith**, Round Lake Beach, IL (US); **Richard Michael Sandusky**, Palatine, IL (US); **Ayberk Abayhan**, Lake Bluff, IL (US); **Masahiko Ishimitsu**, Tokyo (JP)

(60) Division of application No. 10/954,827, filed on Sep. 30, 2004, which is a continuation-in-part of application No. 10/622,374, filed on Jul. 18, 2003, now Pat. No. 7,246,715, which is a continuation-in-part of application No. 09/923,763, filed on Aug. 6, 2001, now Pat. No. 6,732,875.

**Publication Classification**

(51) **Int. Cl.**  
*B65D 51/18* (2006.01)  
(52) **U.S. Cl.** ..... 220/253

Correspondence Address:

**BANNER & WITCOFF, LTD.**  
TEN SOUTH WACKER DRIVE, SUITE 3000  
CHICAGO, IL 60606

(57) **ABSTRACT**

A reclosable lid (10) for a container holding a flowable substance has a cover (12) having an opening (28) and a moveable element (850) connected to the cover (12). The moveable element (850) is moveable between at least one open position, wherein the flowable substance may flow through the opening, and at least one closed position, wherein the opening is obstructed. In some embodiments, the lid (10) may include an overlay (250) moveable between at least one open position and at least one closed position.

(73) Assignee: **Solo Cup Operating Corporation**, Highland Park, IL (US)

(21) Appl. No.: **12/029,240**

(22) Filed: **Feb. 11, 2008**

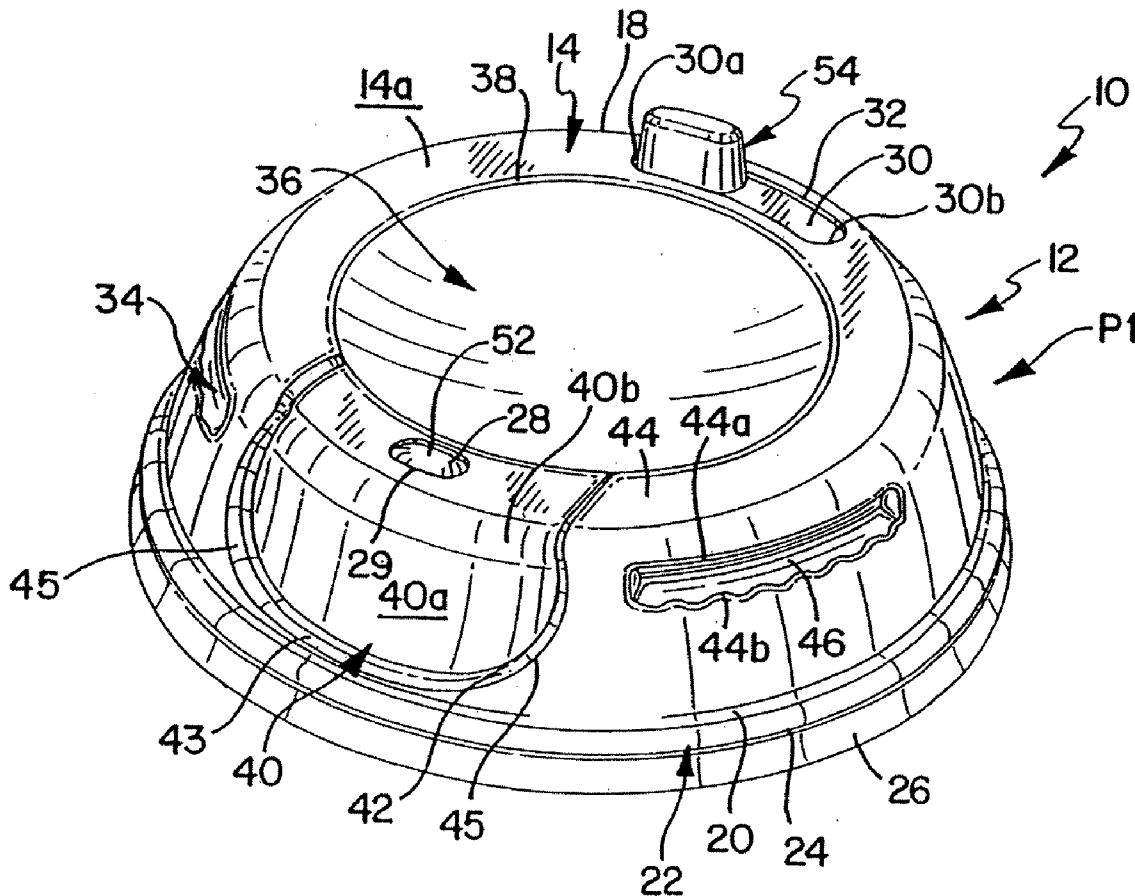

FIG. 1

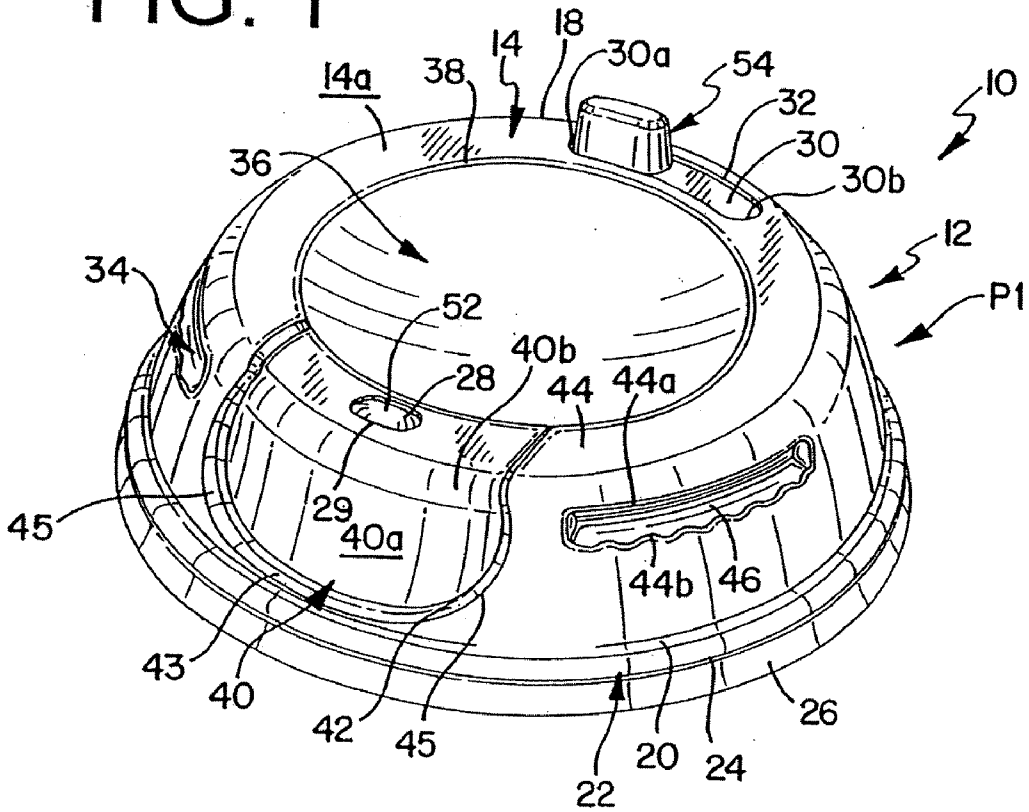
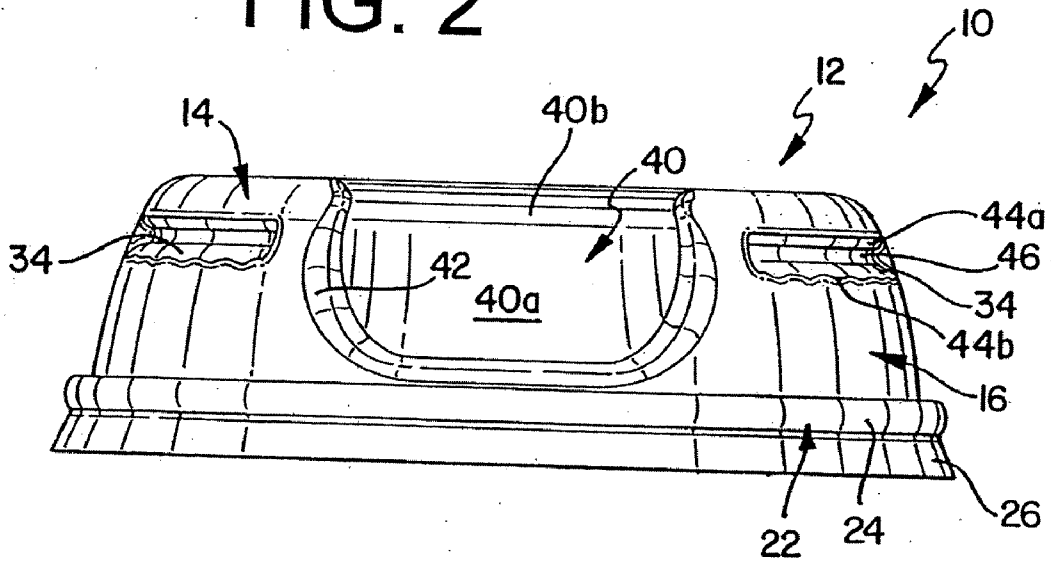
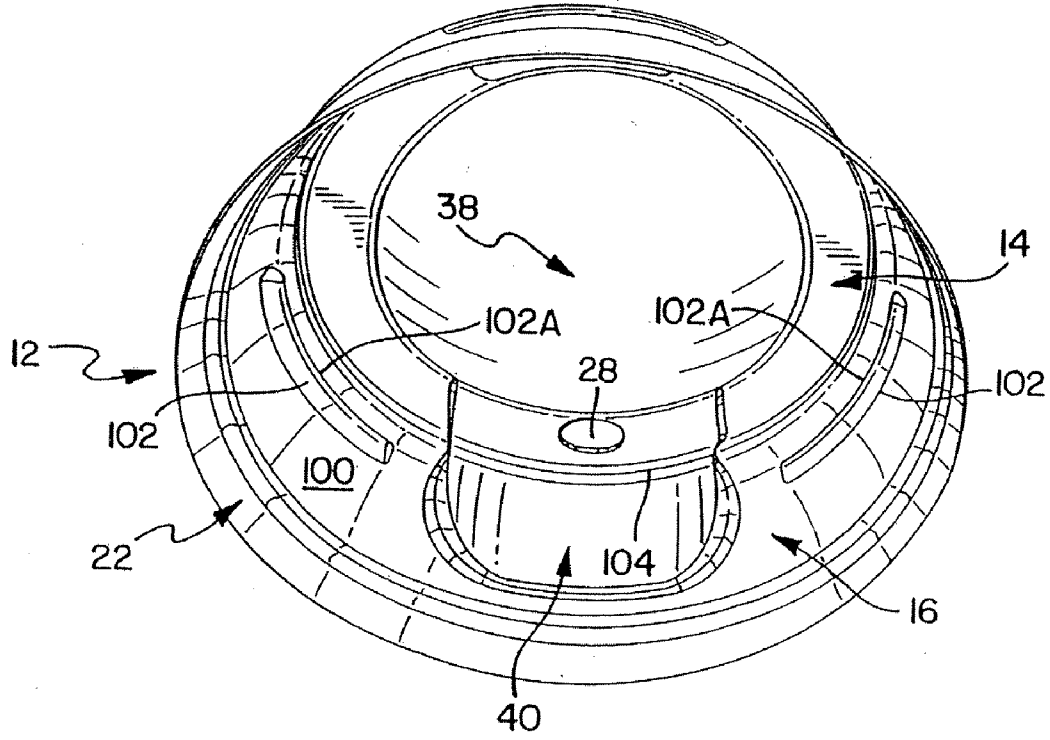

FIG. 2



# FIG. 3



# FIG. 4

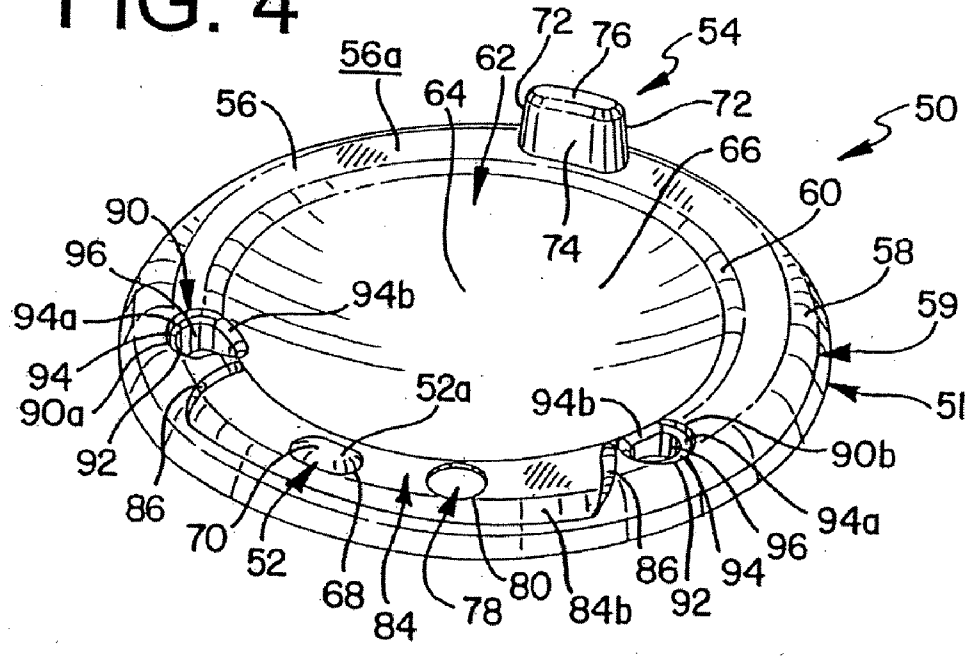

# FIG. 5

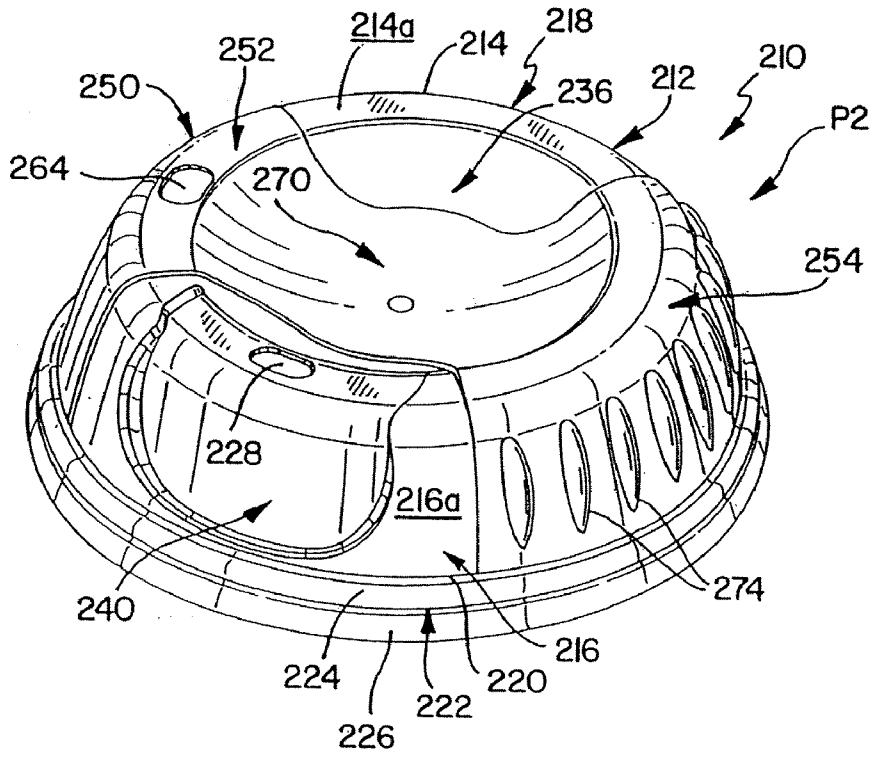

# FIG. 6

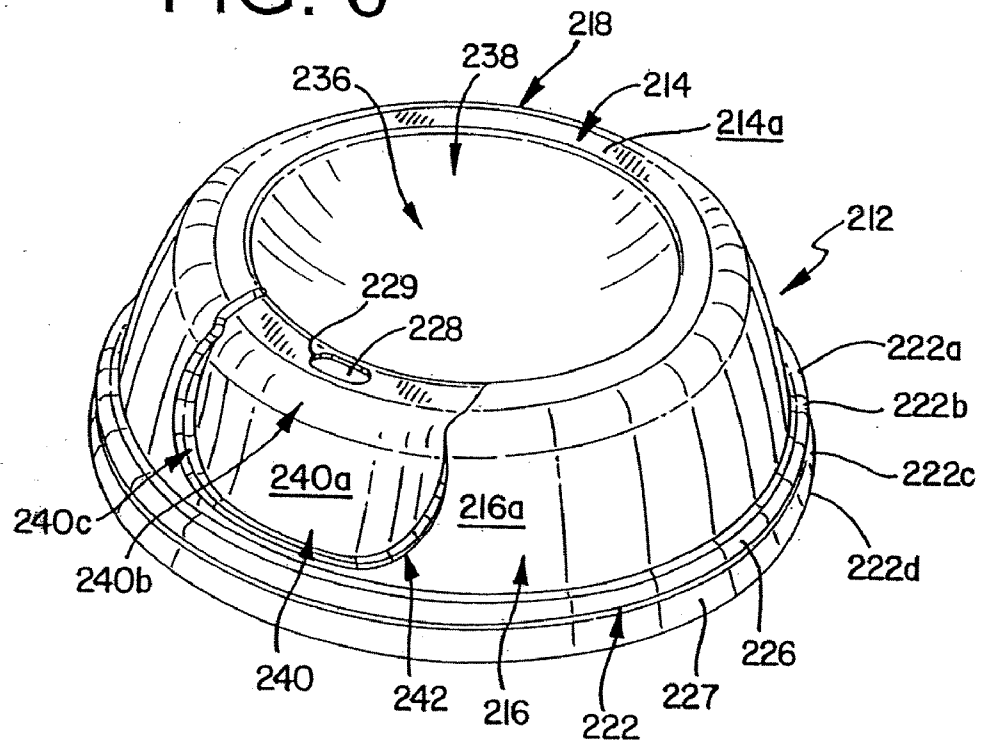

# FIG. 7

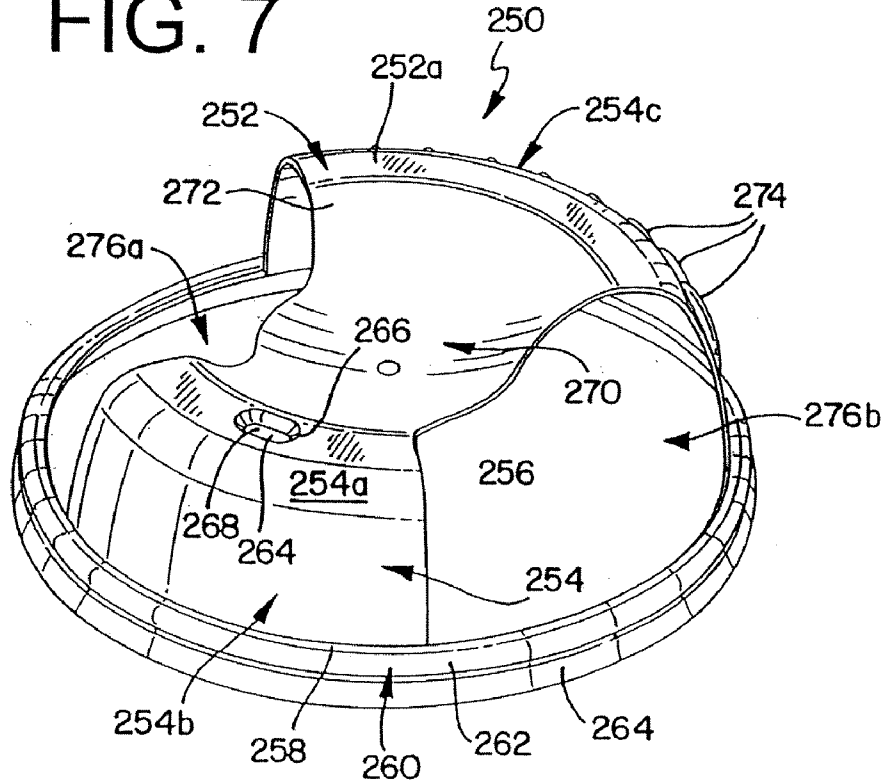

# FIG. 8

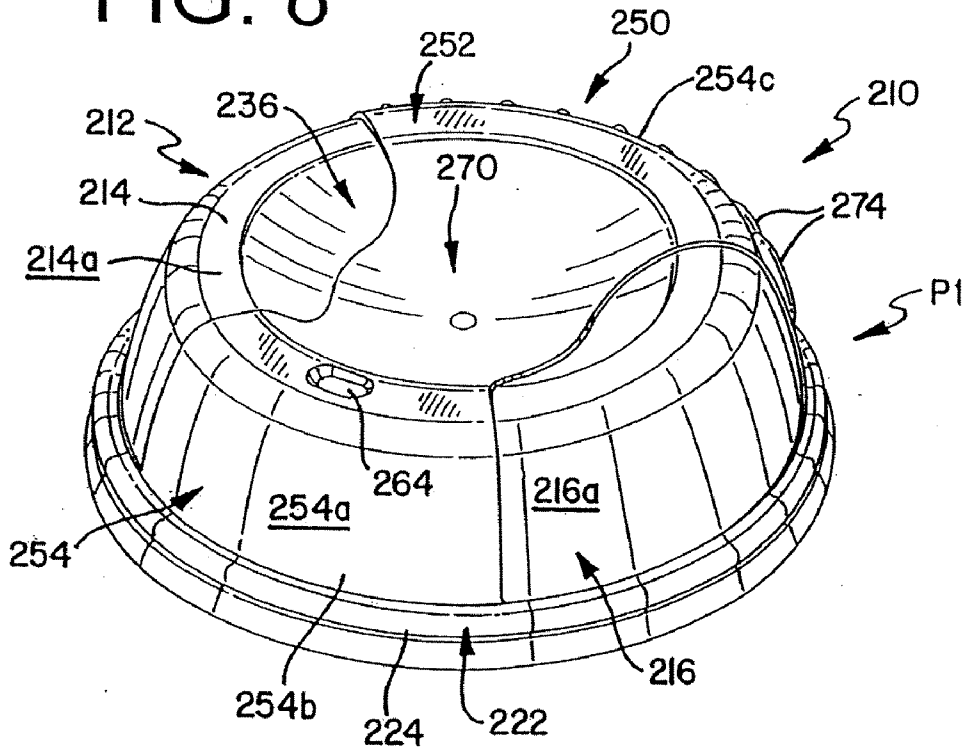

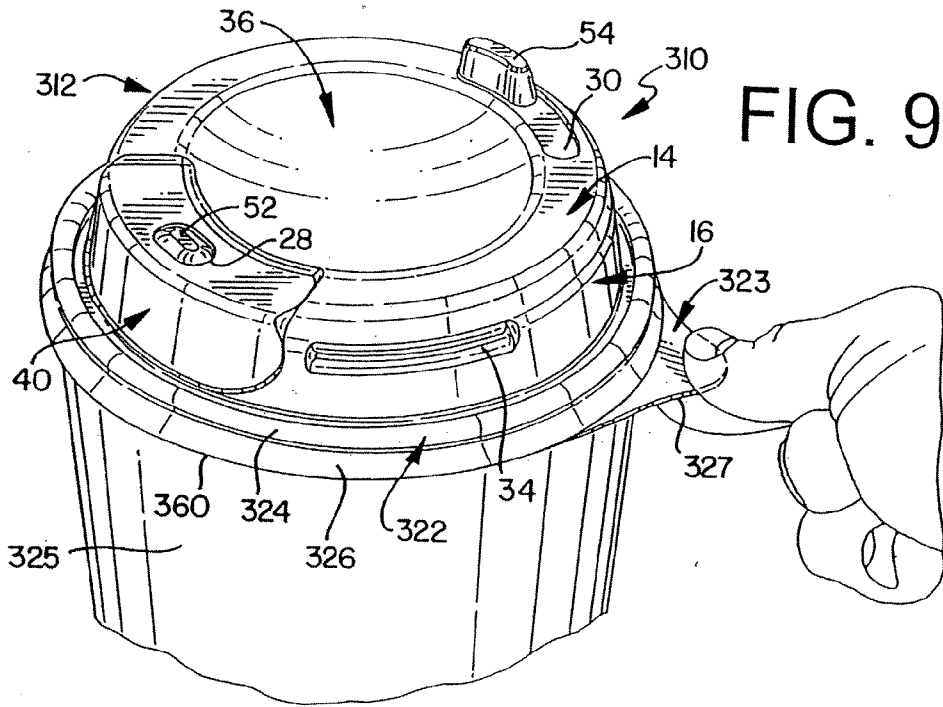
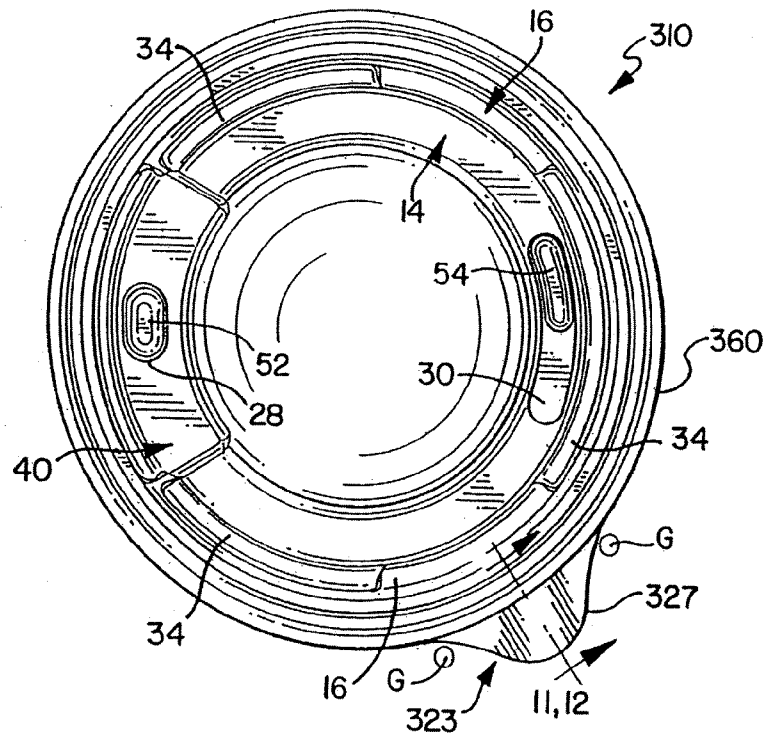
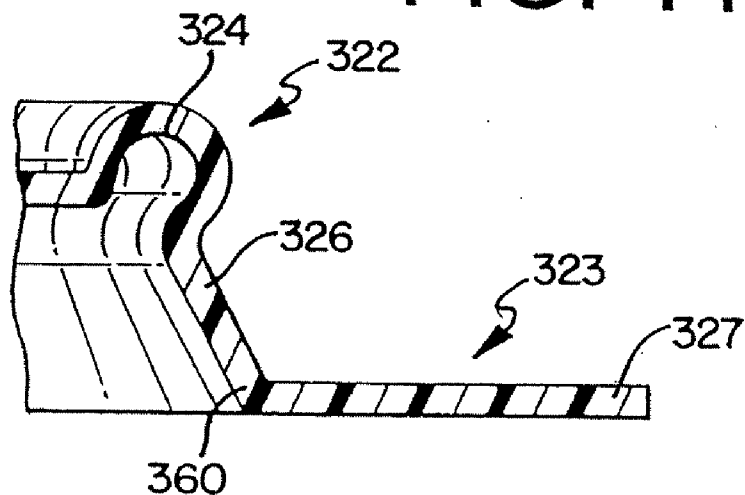

FIG. 10



# FIG. 11



# FIG. 12

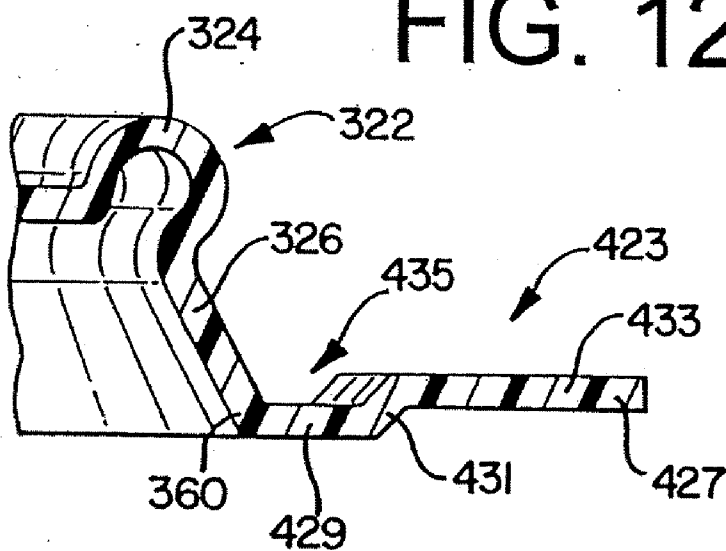

# FIG. 13

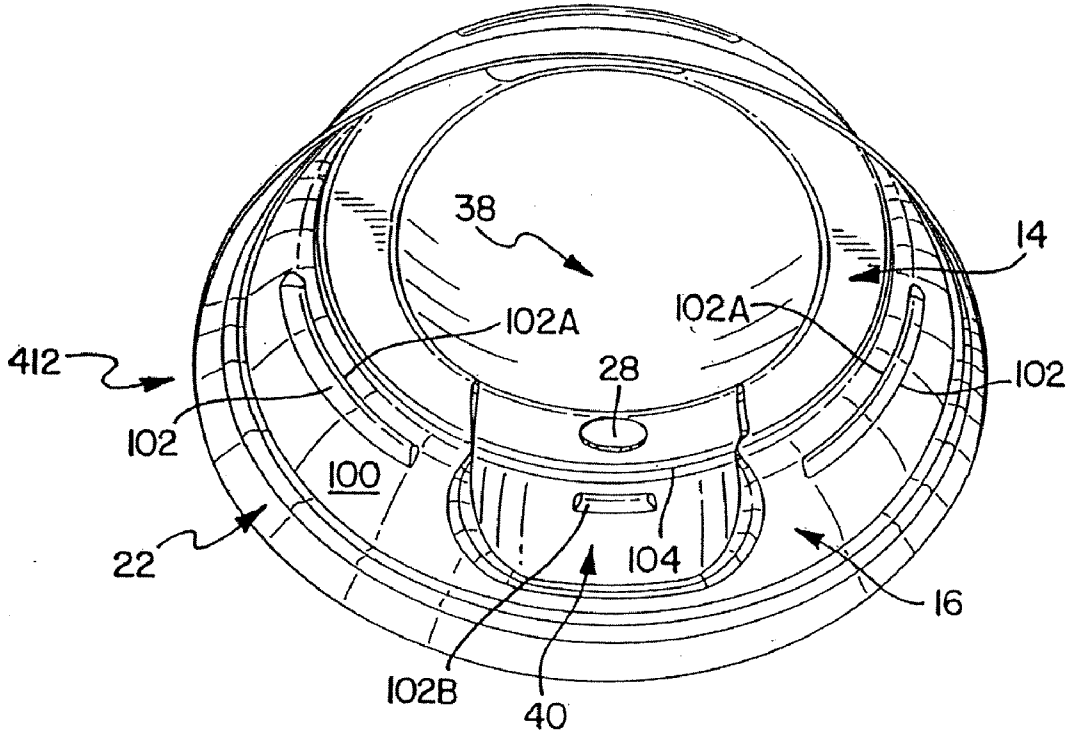

# FIG. 14

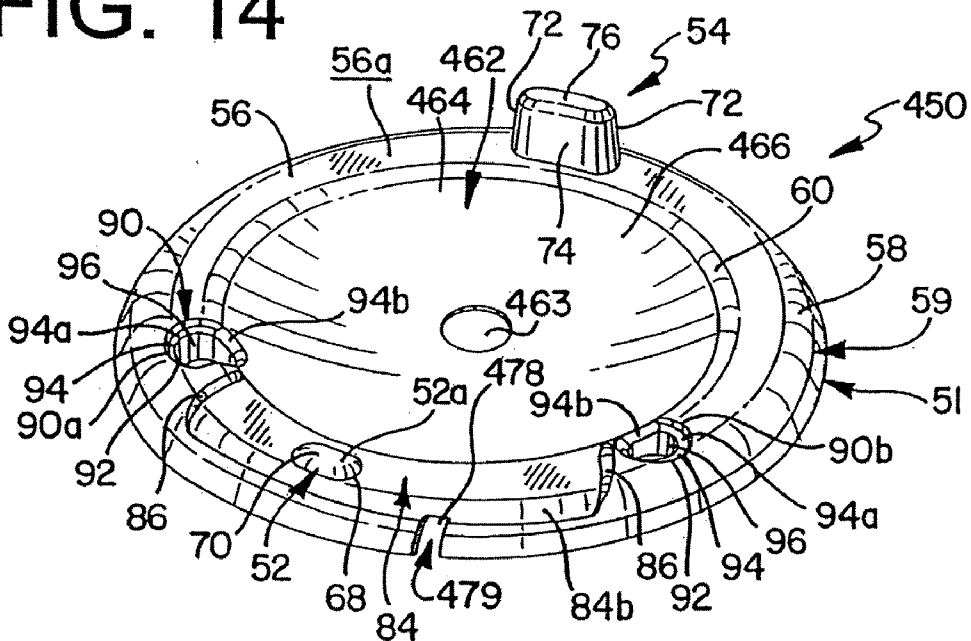



# FIG. 15

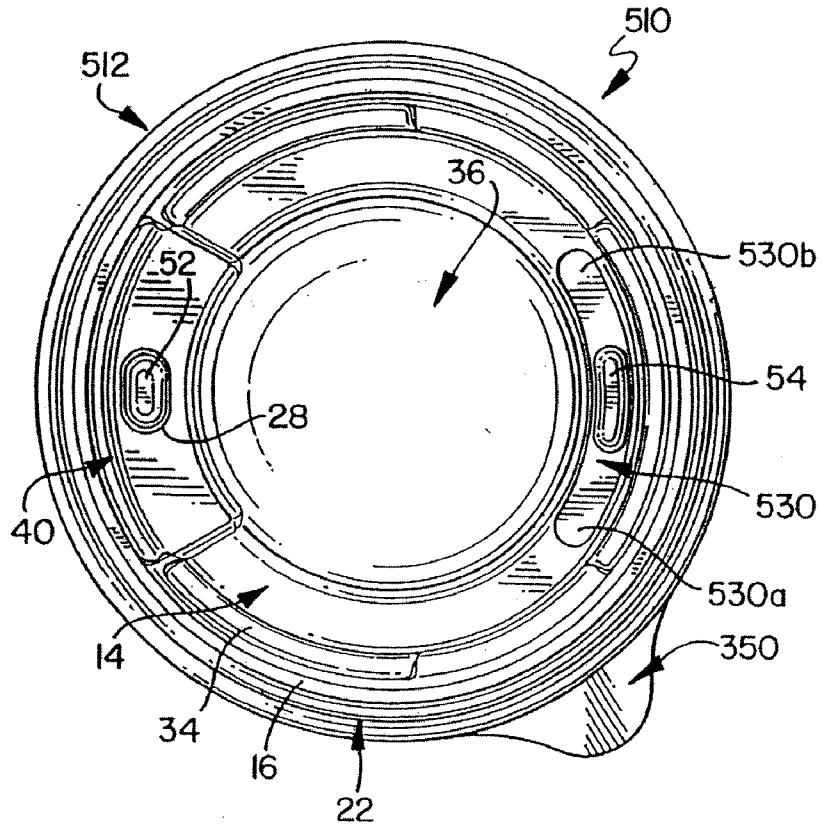

# FIG. 16

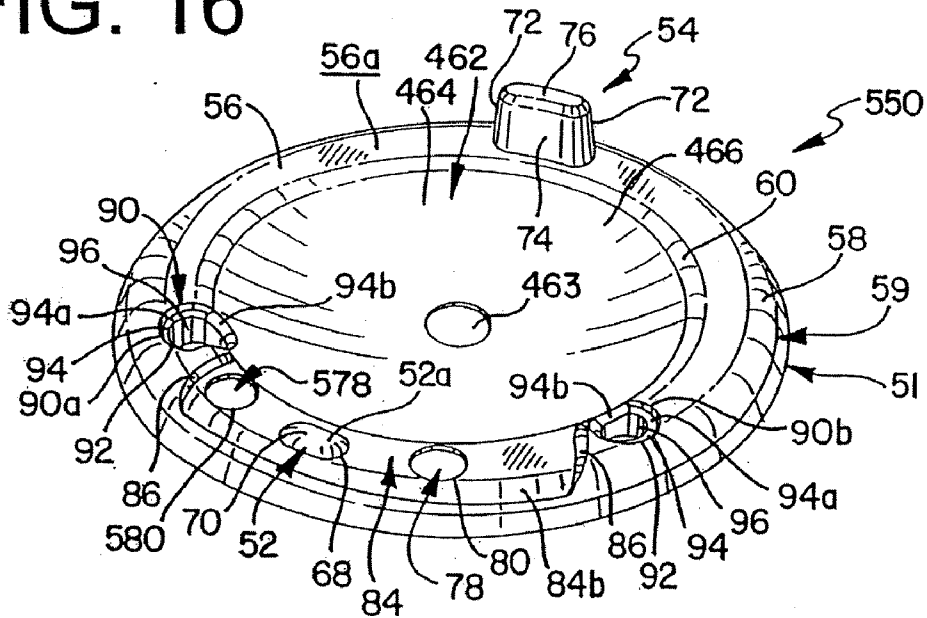

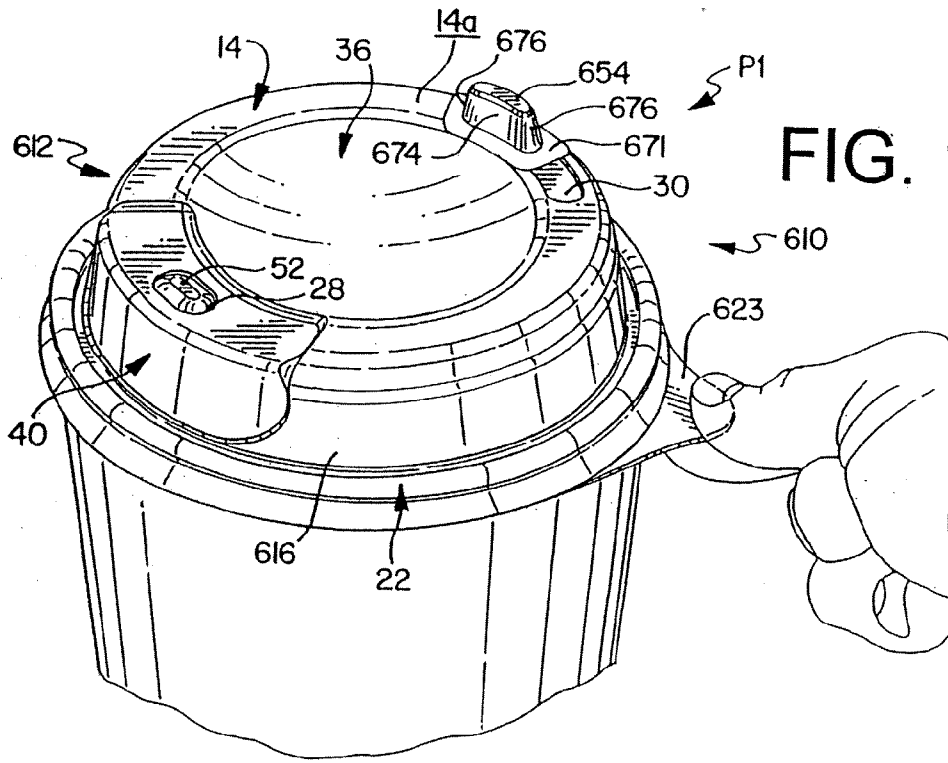
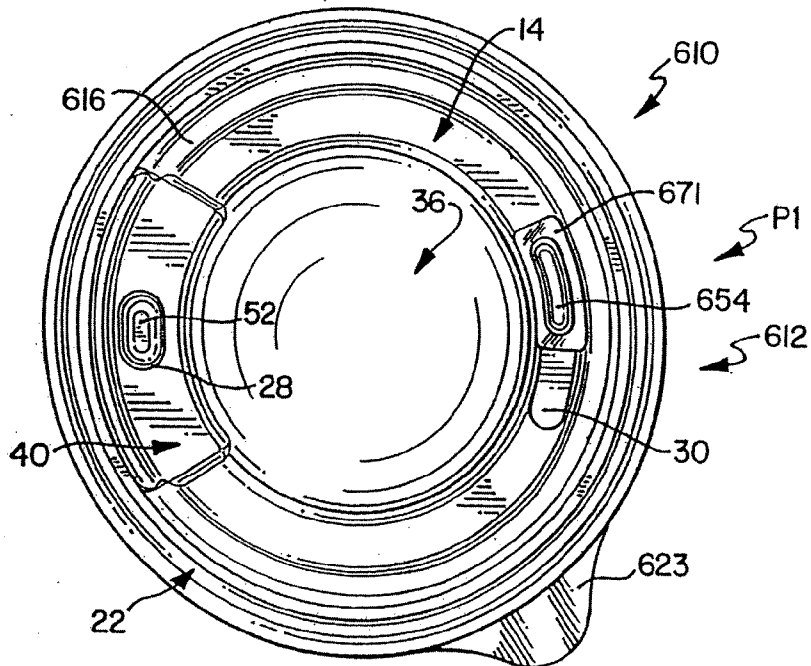
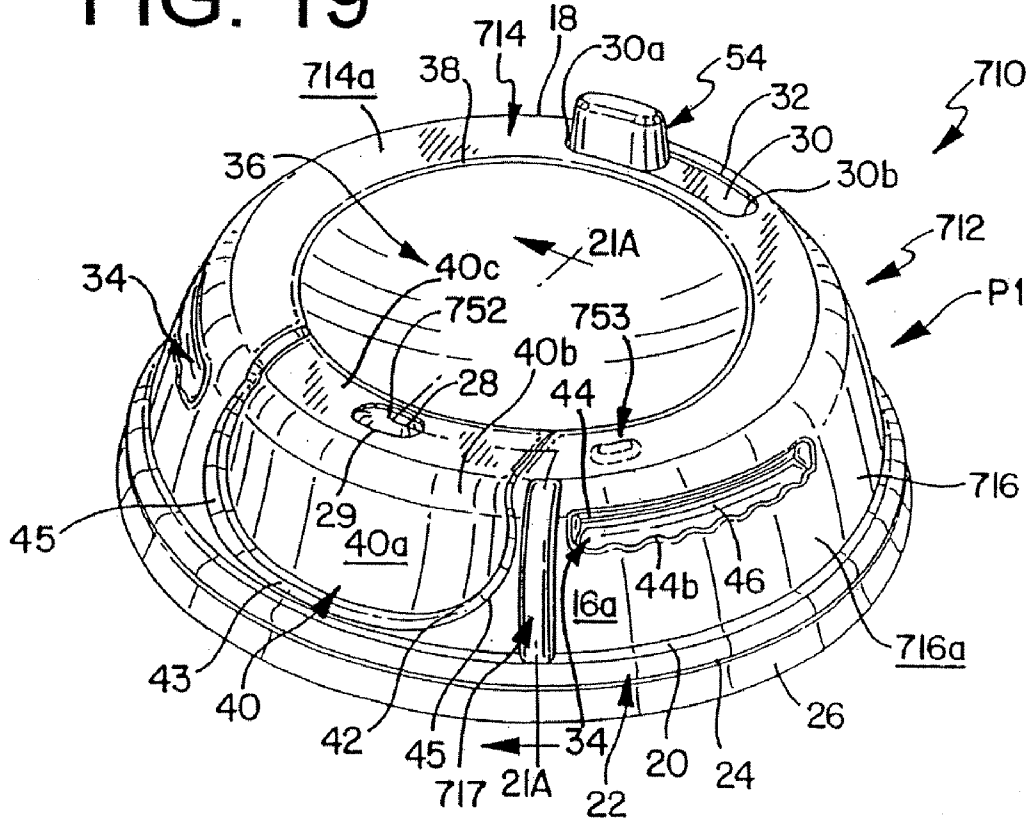

FIG. 18



# FIG. 19



# FIG. 20

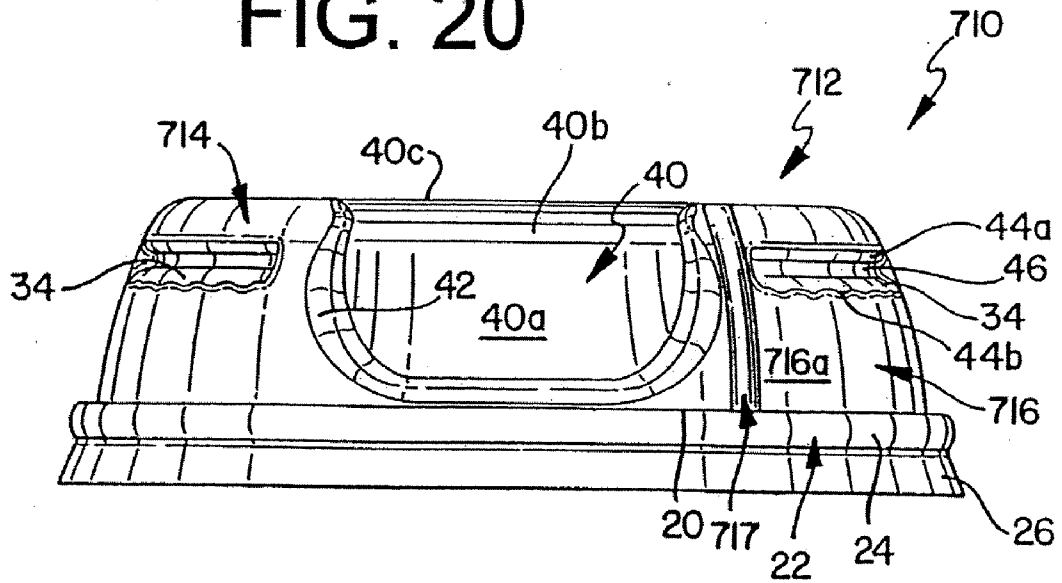

FIG. 21A

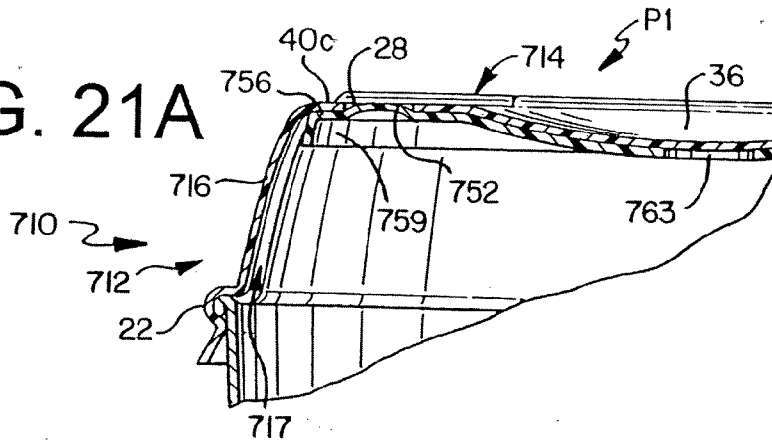

FIG. 21B

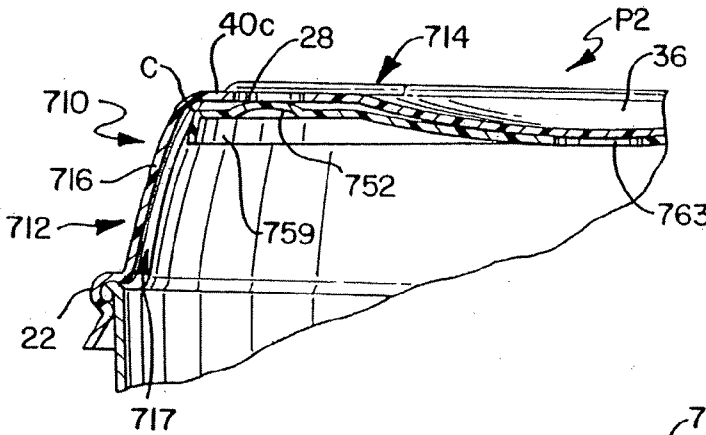

FIG. 22

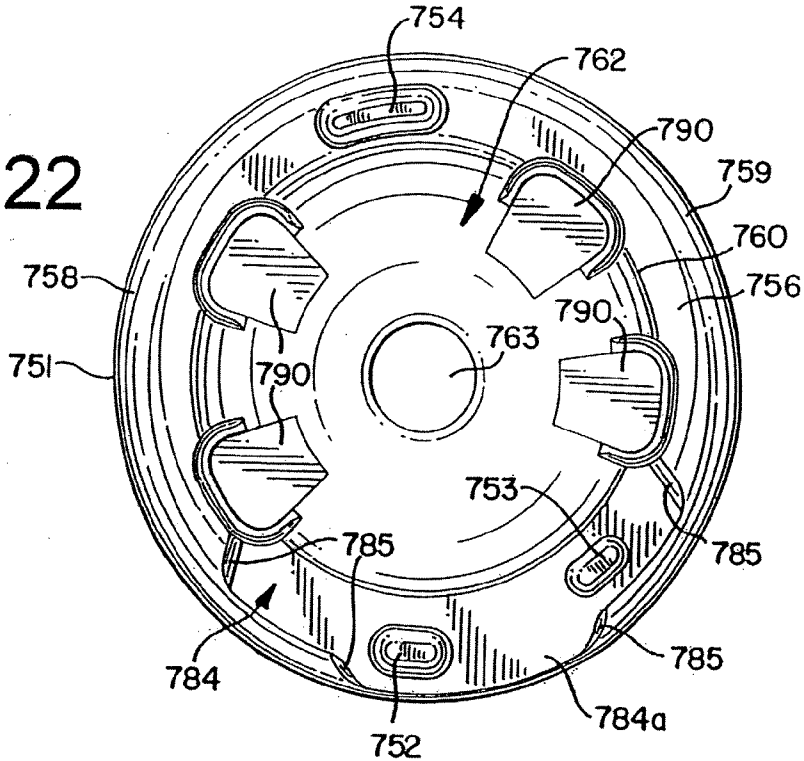

FIG. 23

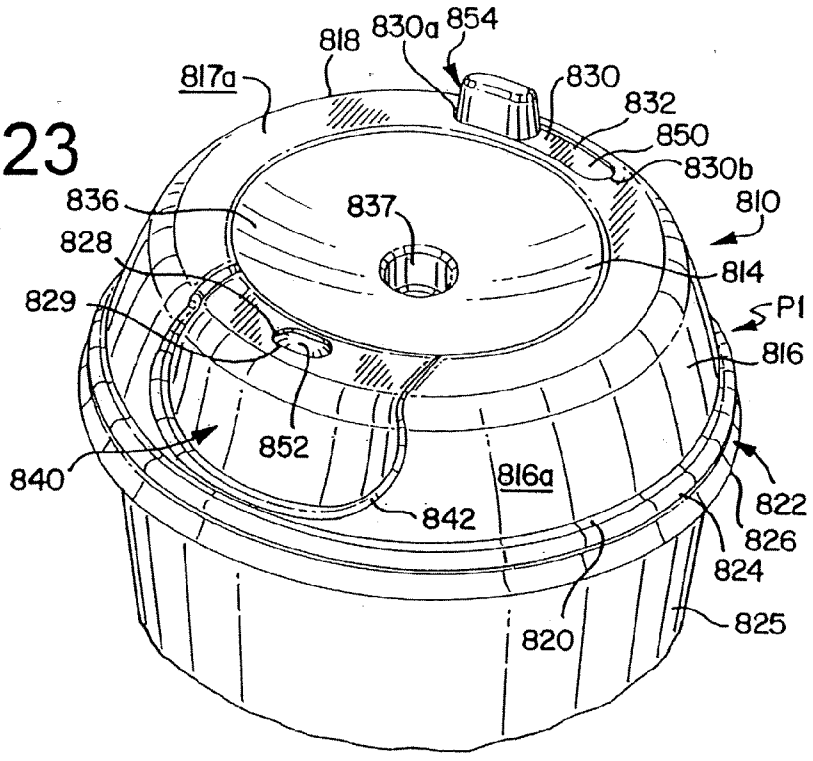
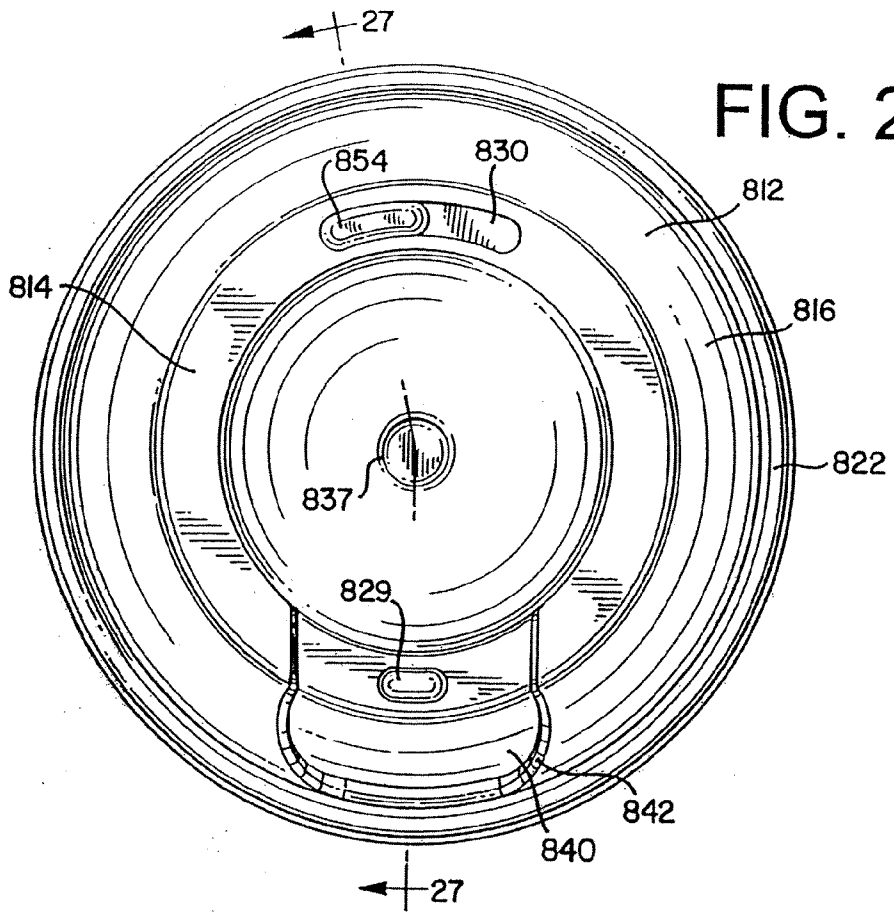
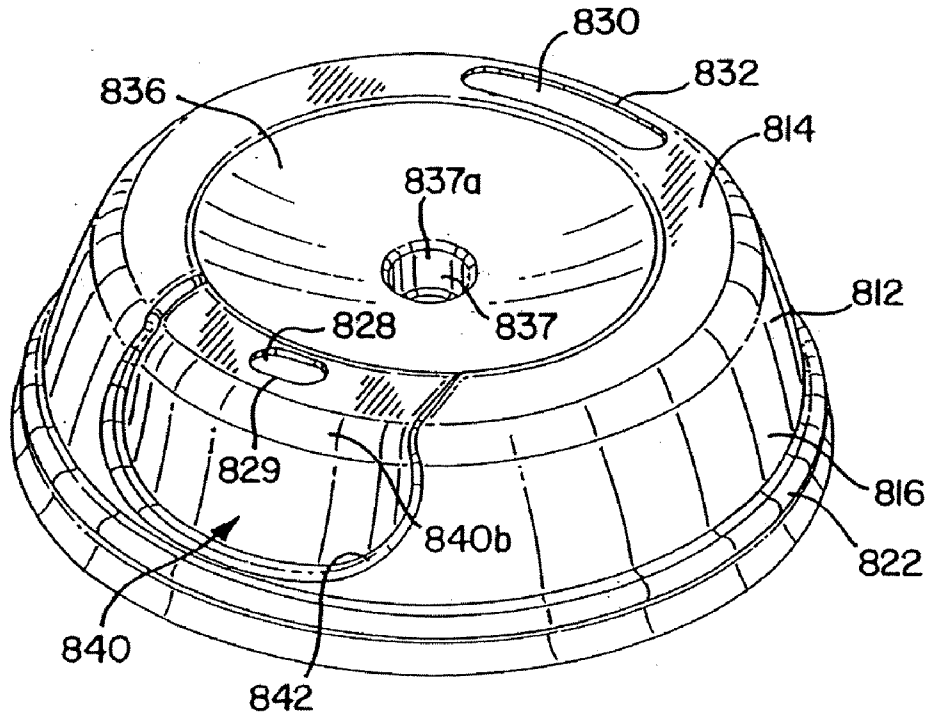

FIG. 24



# FIG. 25



# FIG. 26

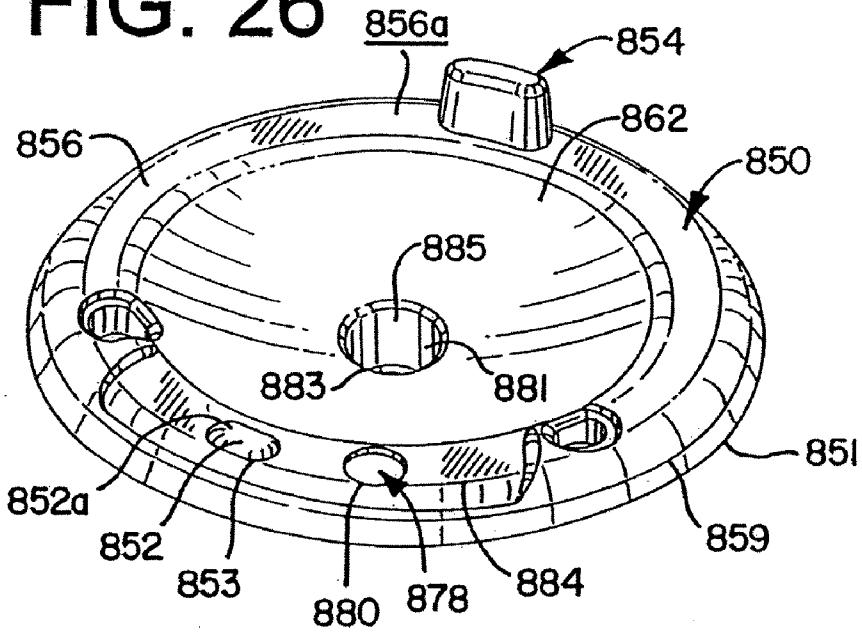

# FIG. 27

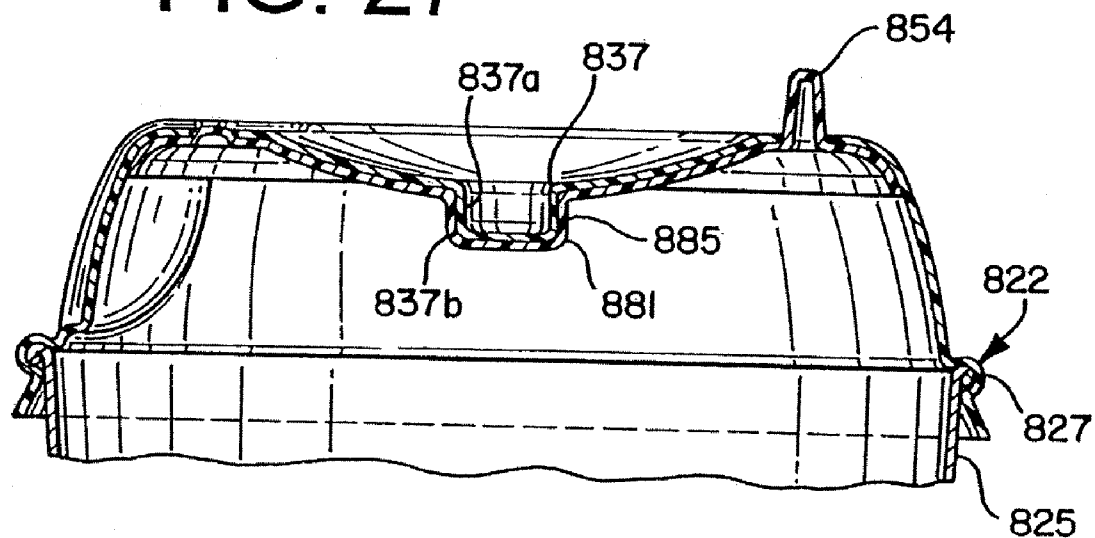

# FIG. 28

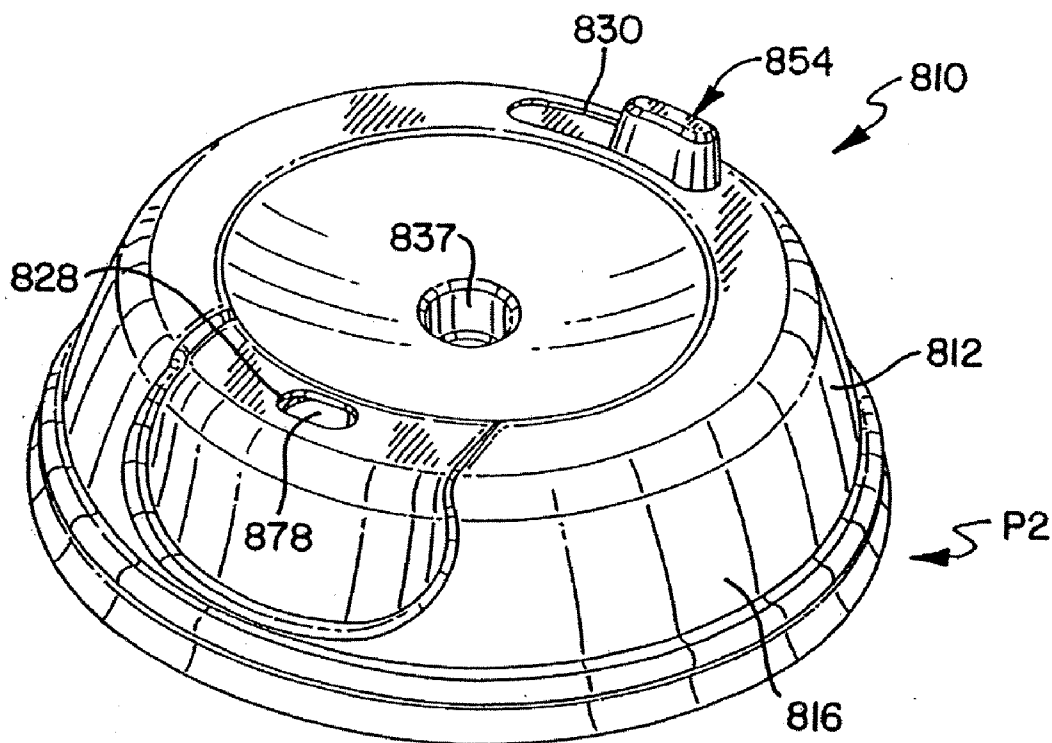

FIG. 29

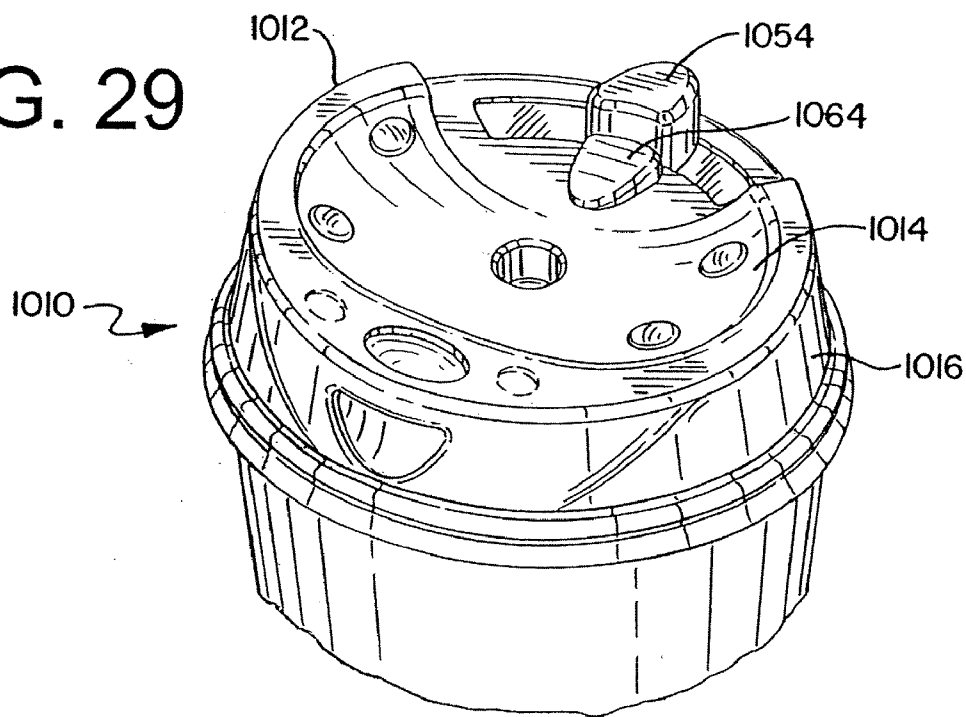

FIG. 30

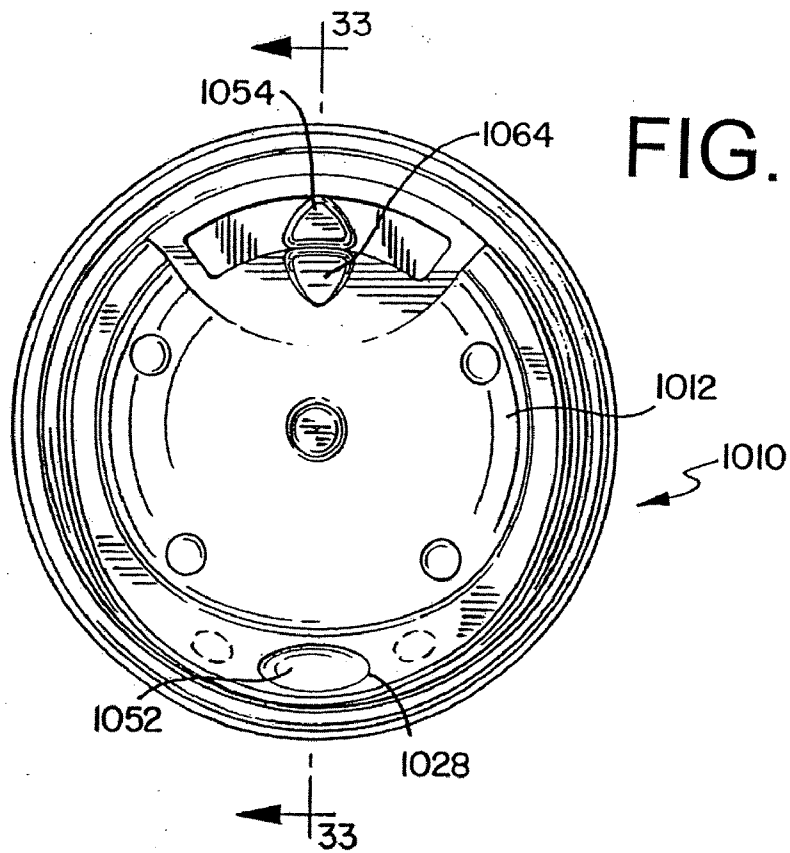



FIG. 31

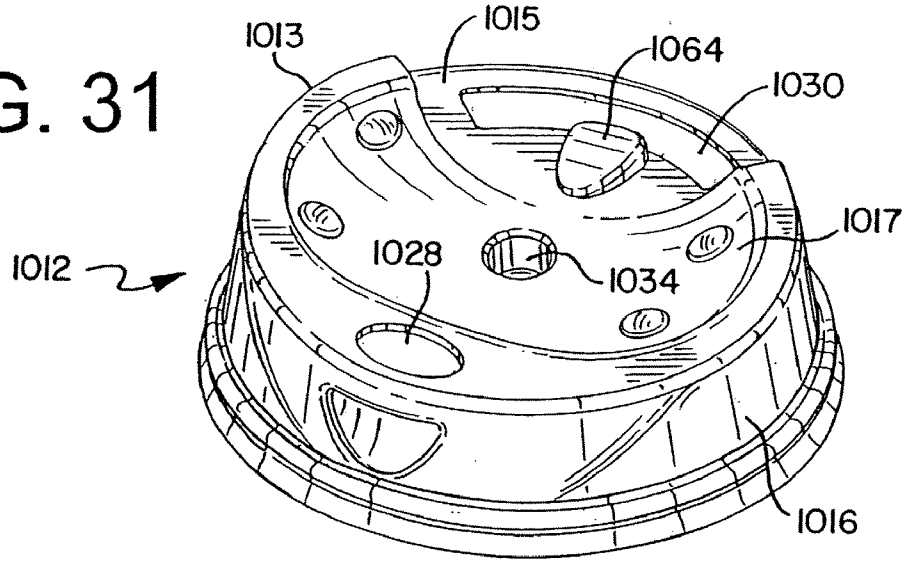

FIG. 32

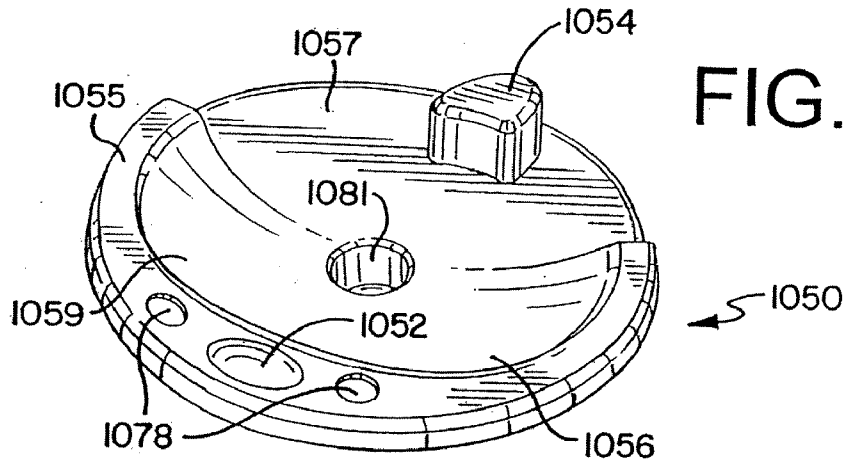

FIG. 33

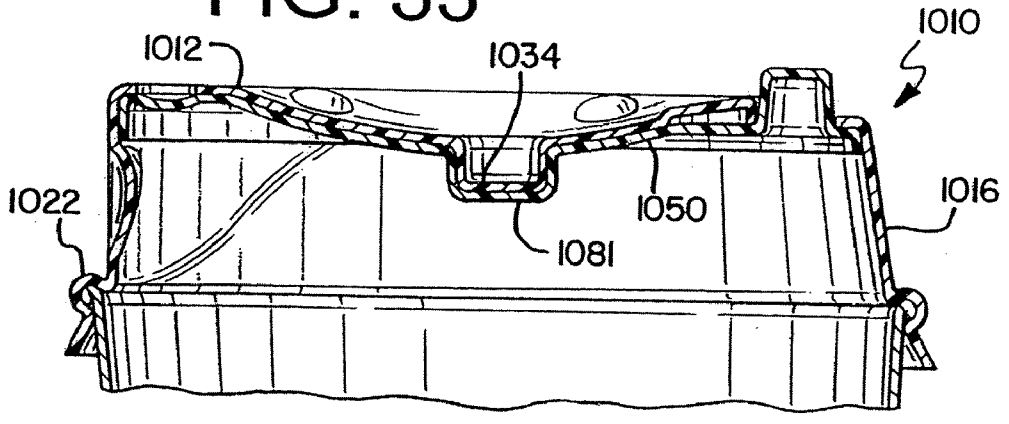

FIG. 34

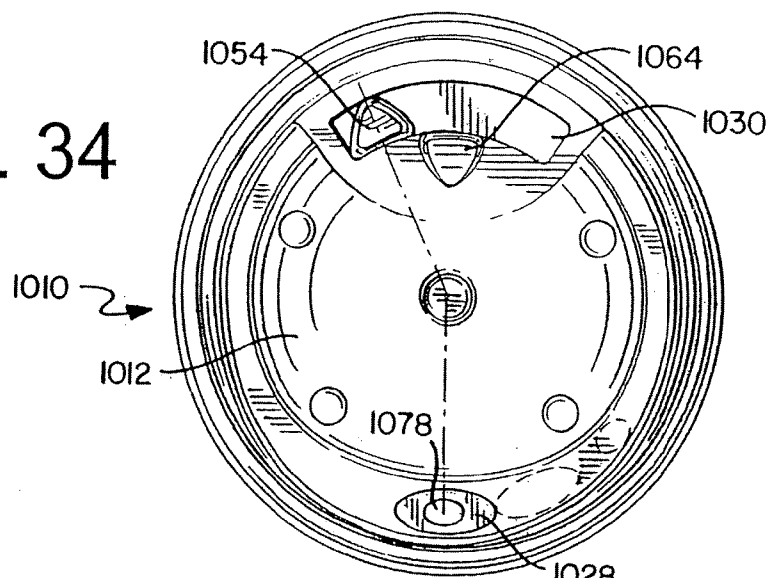

FIG. 35

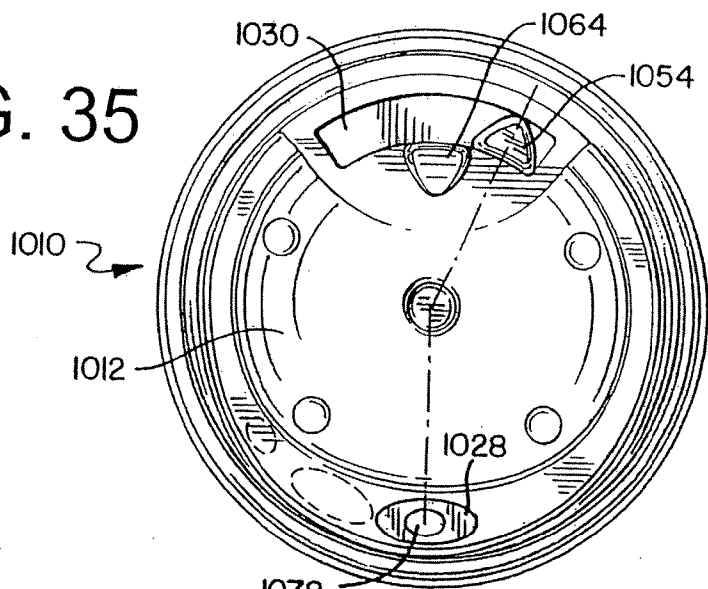

FIG. 36

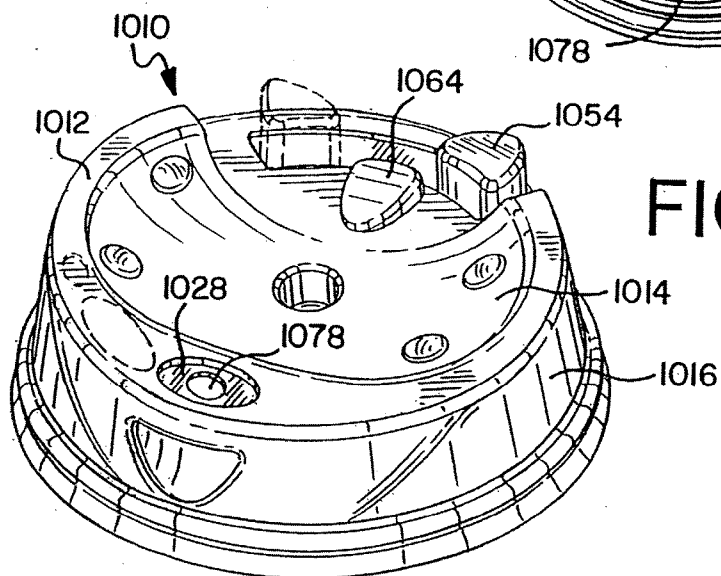

FIG. 37

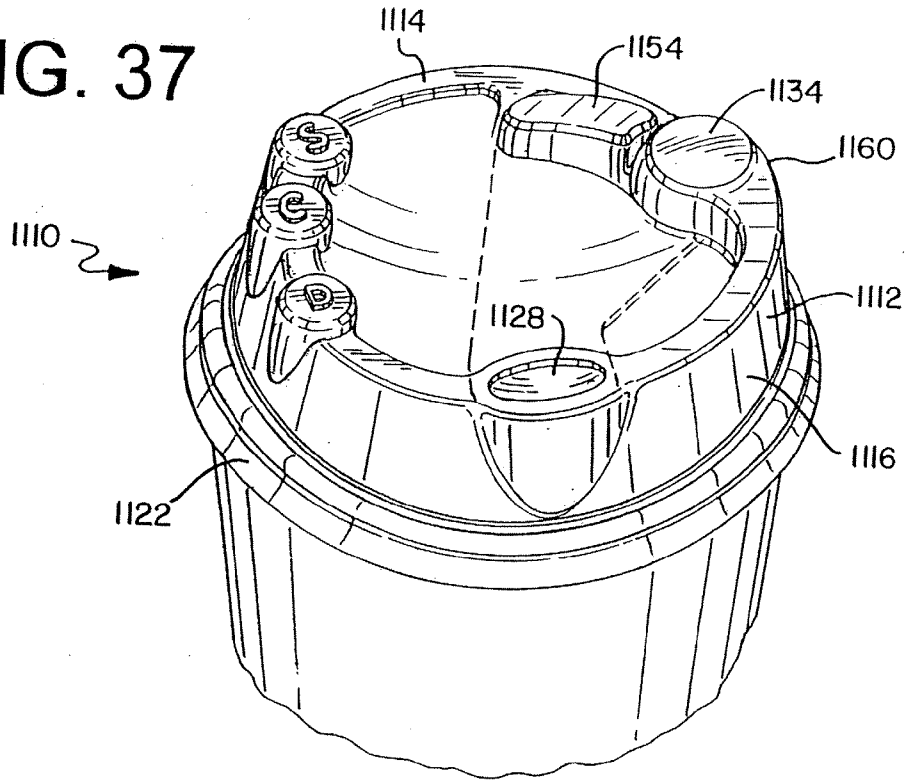
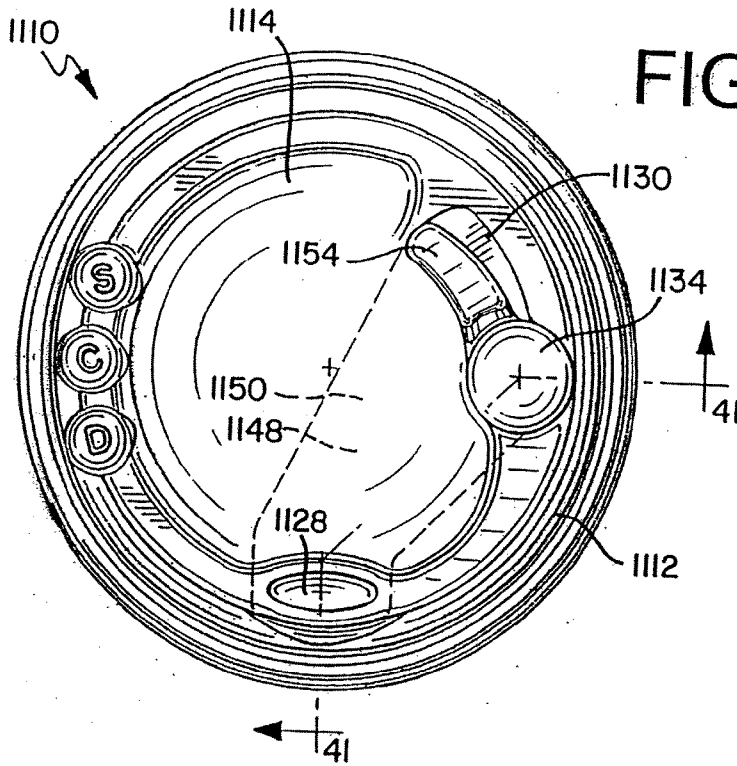

FIG. 38



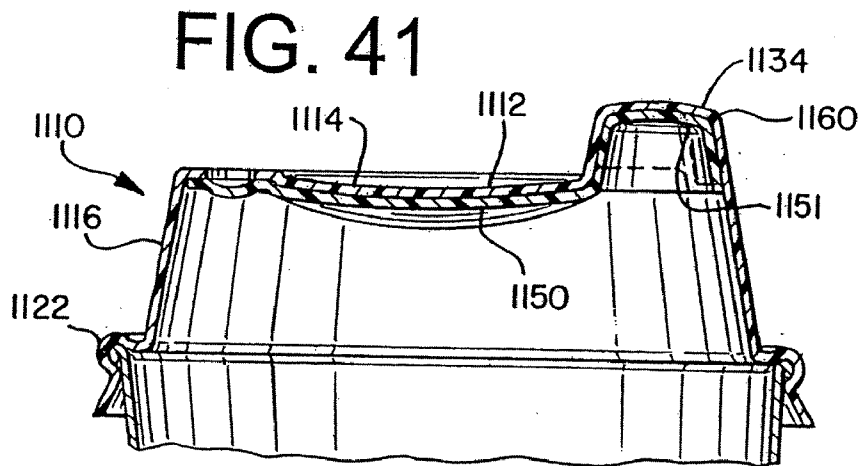
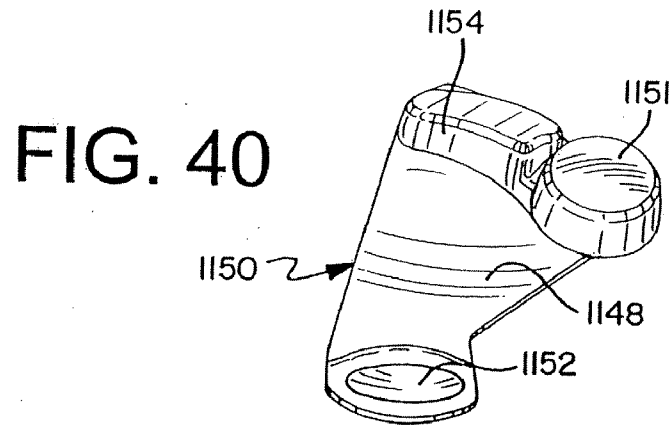
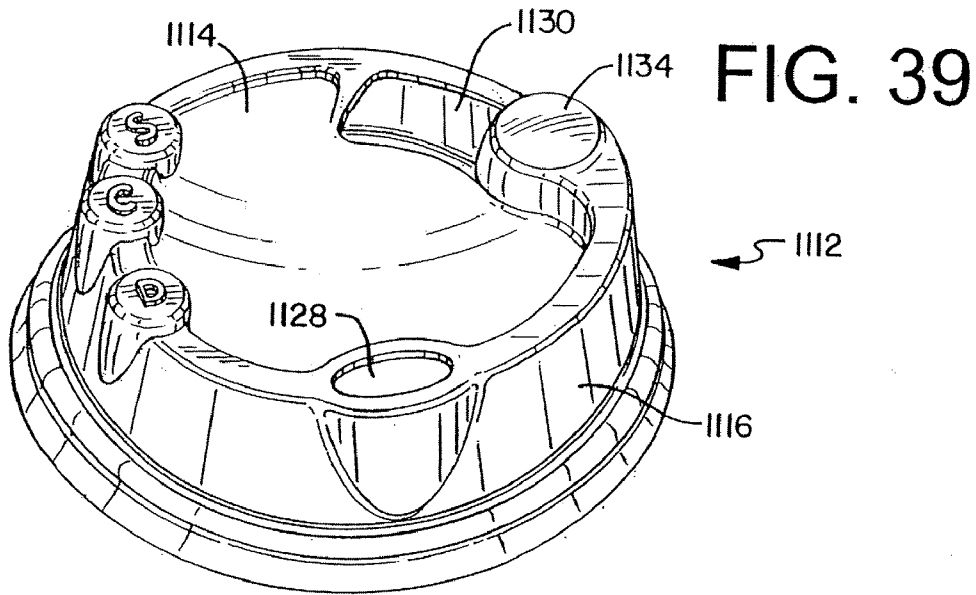

FIG. 42

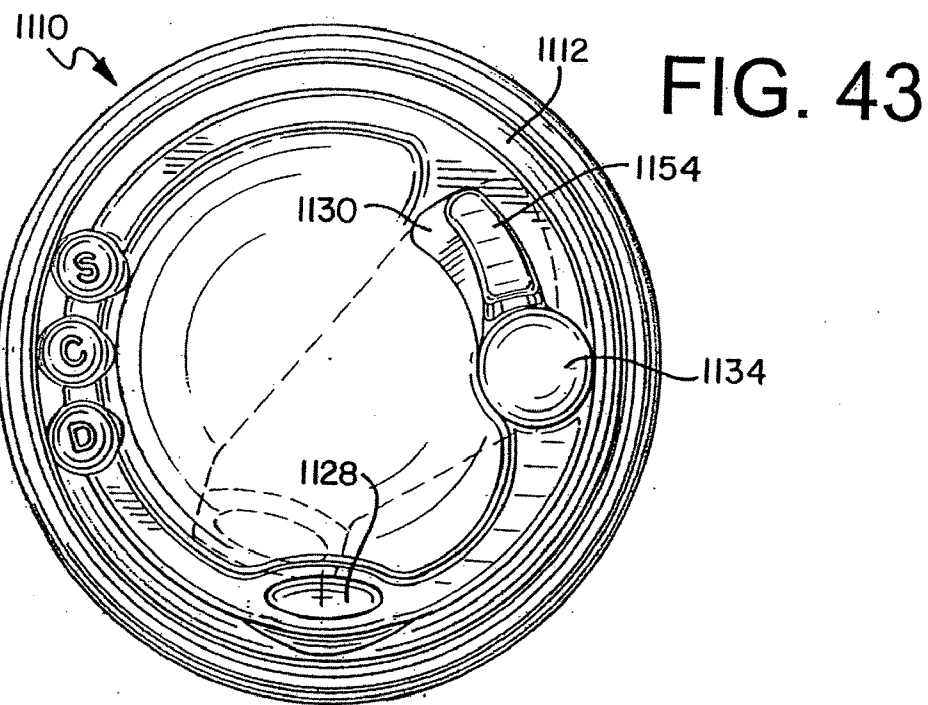
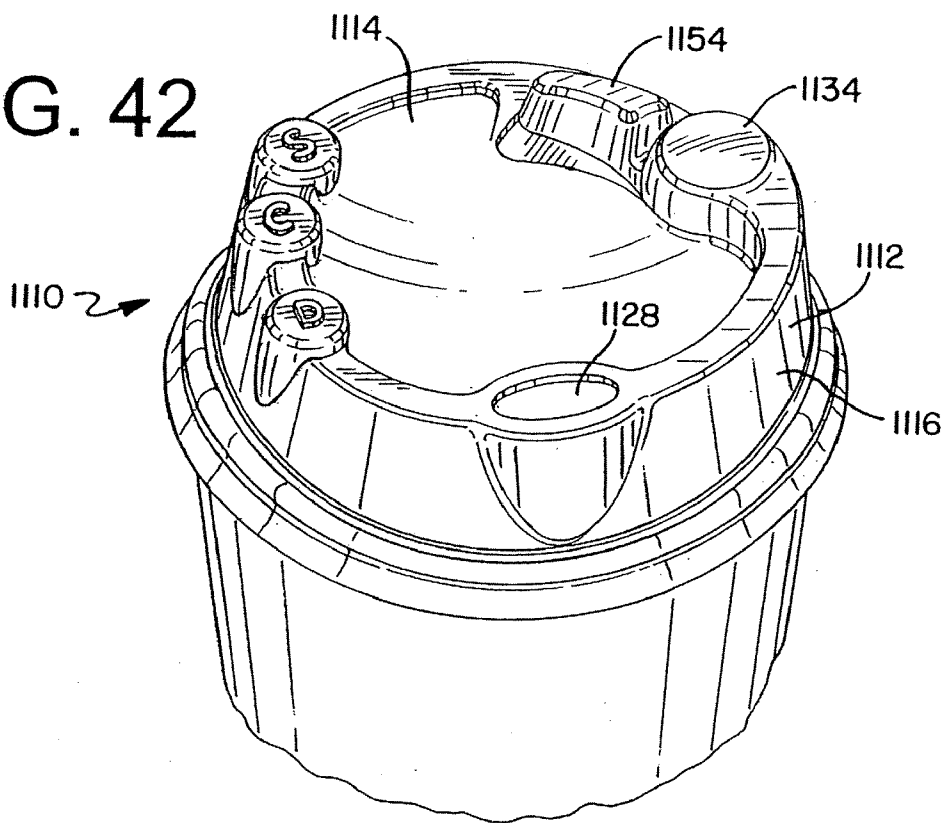

FIG. 44

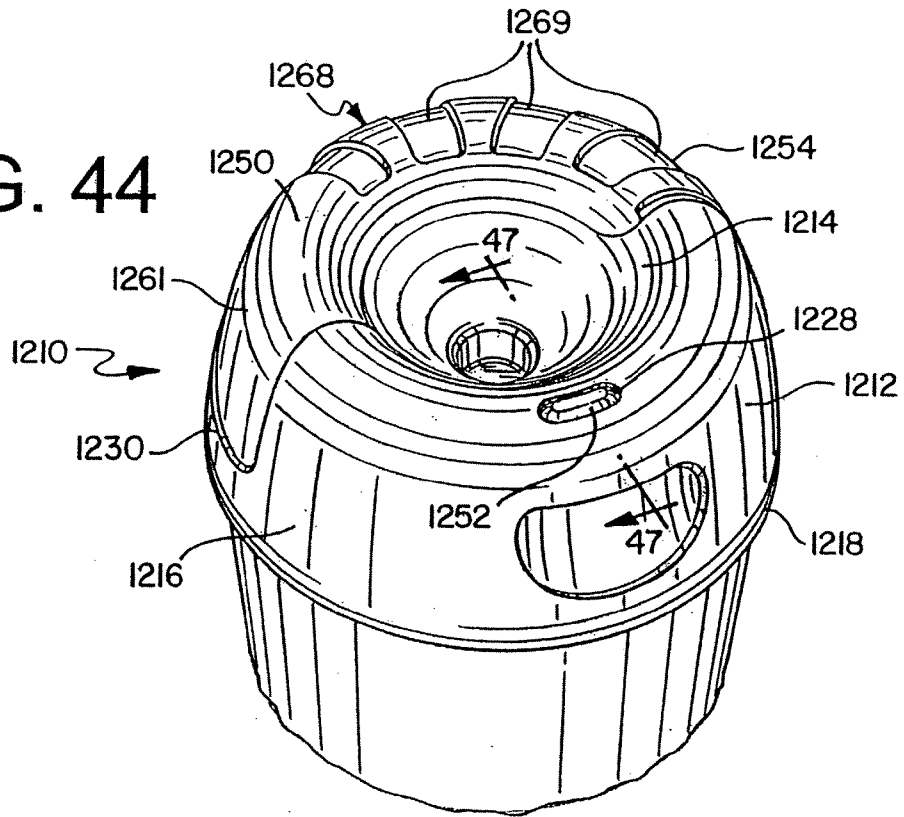

FIG. 45

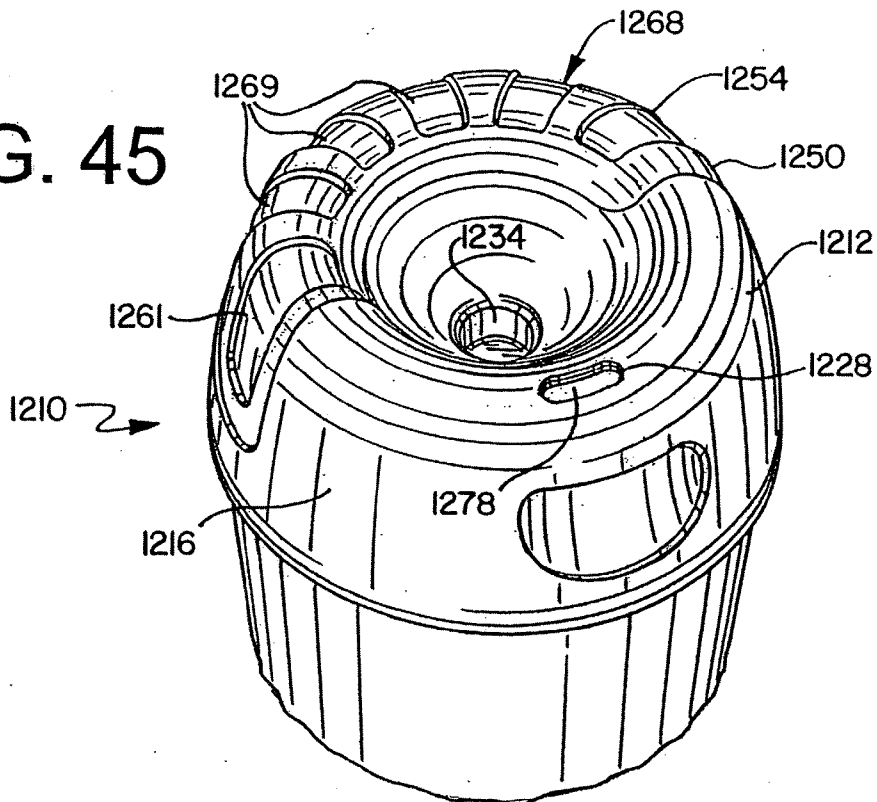

FIG. 46

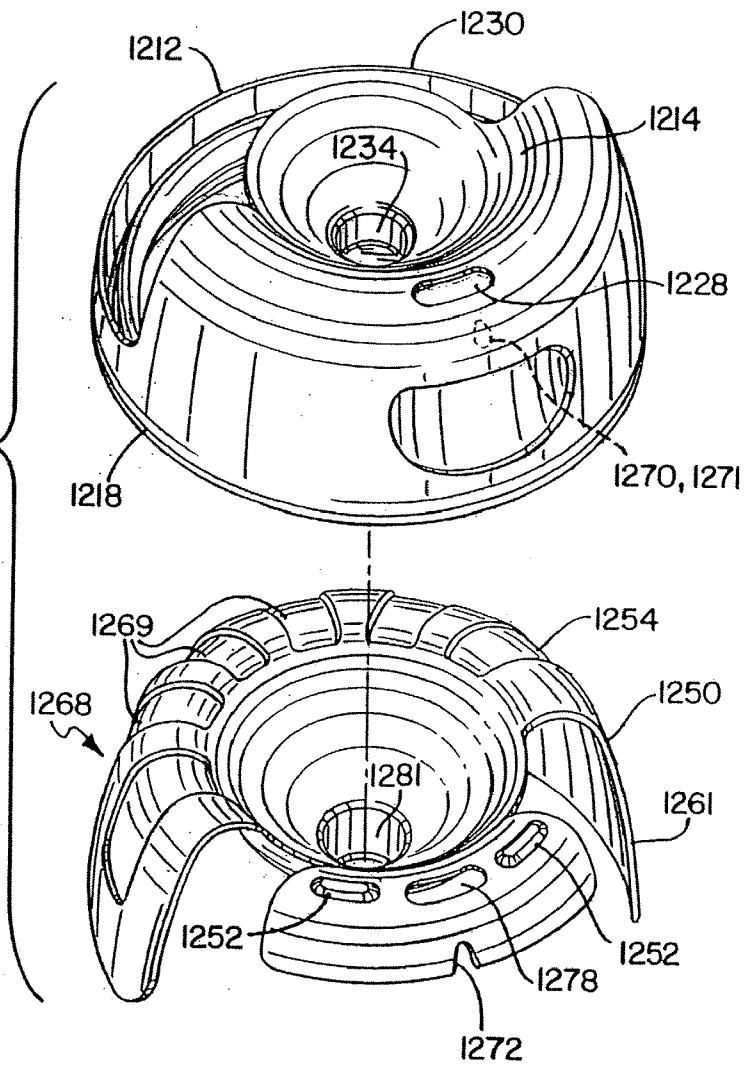

FIG. 47

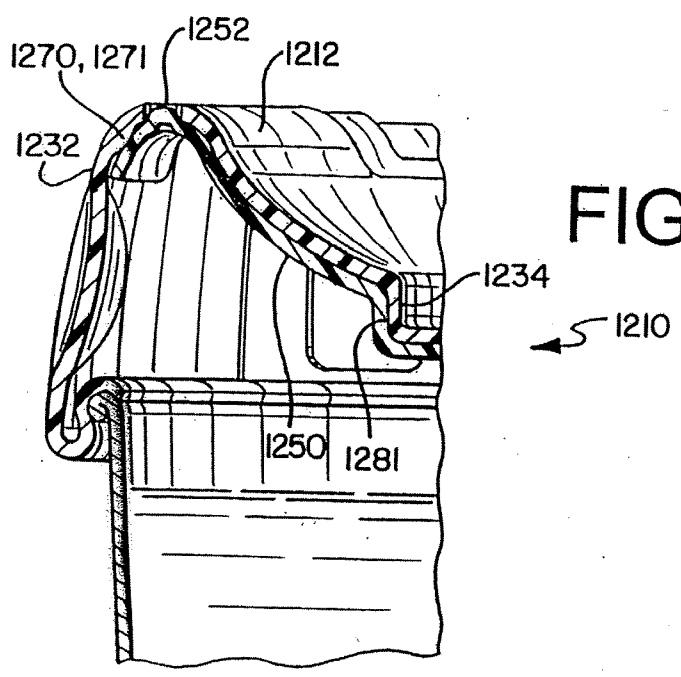

FIG. 48

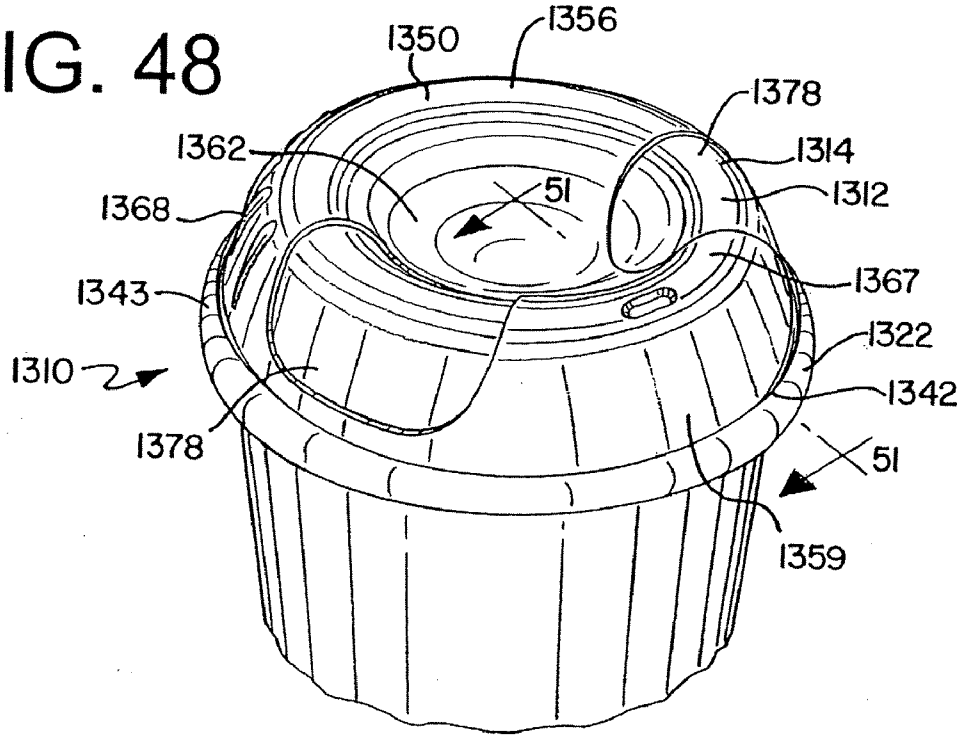

FIG. 49

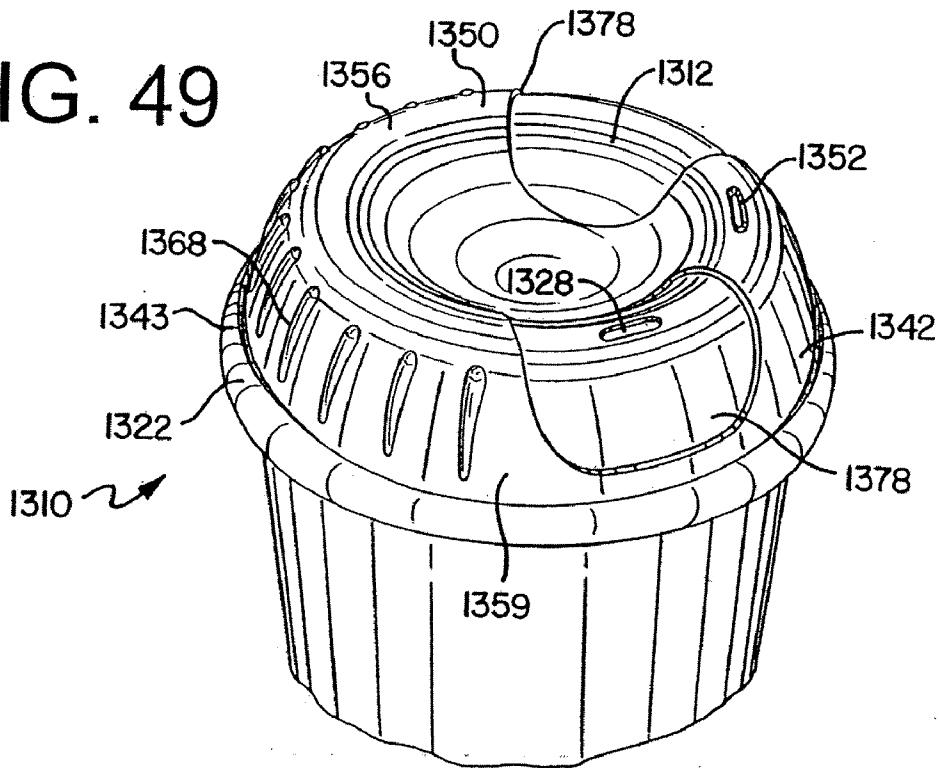



FIG. 50

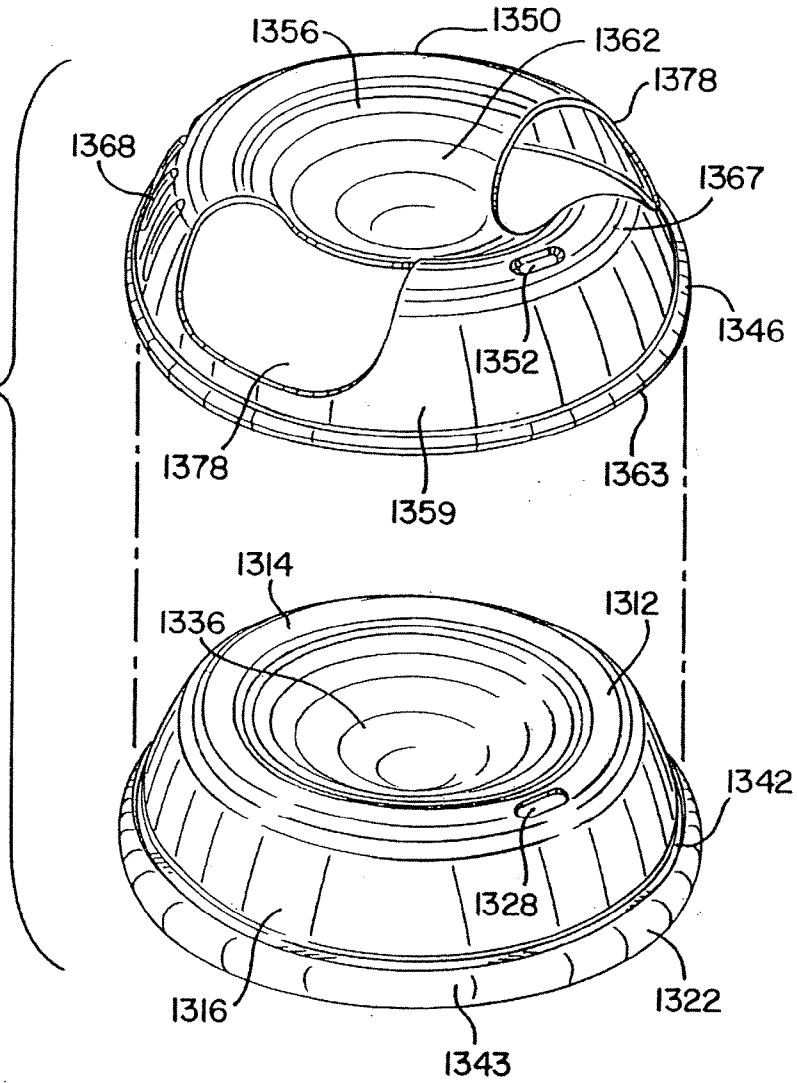
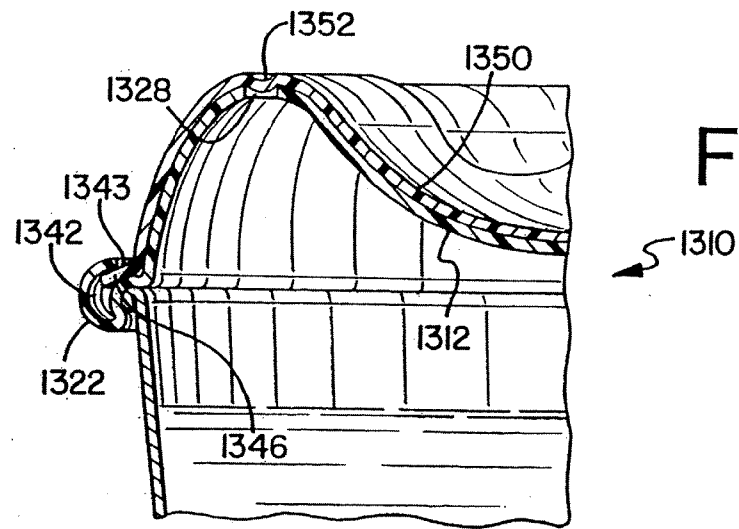

FIG. 51



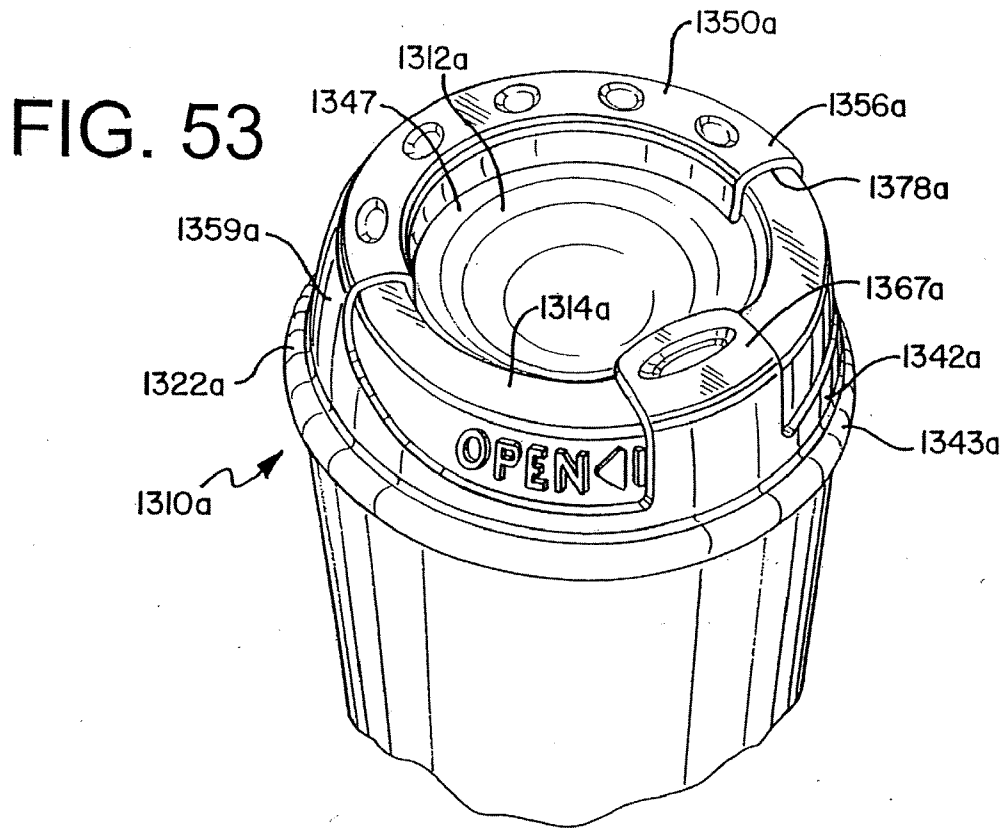
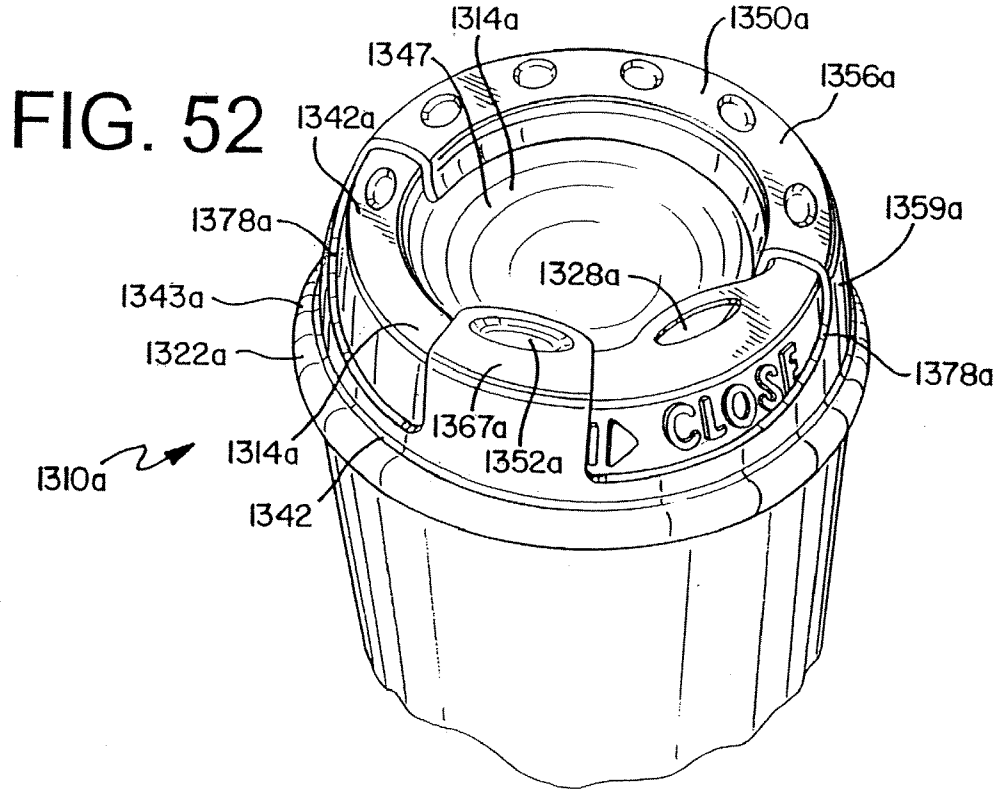

FIG. 54

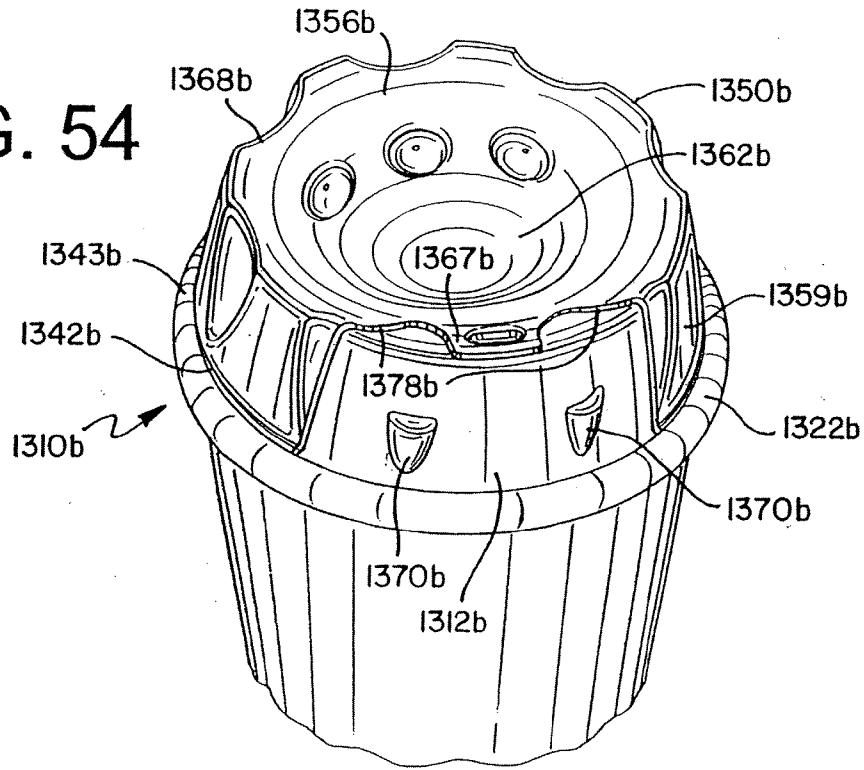

FIG. 55

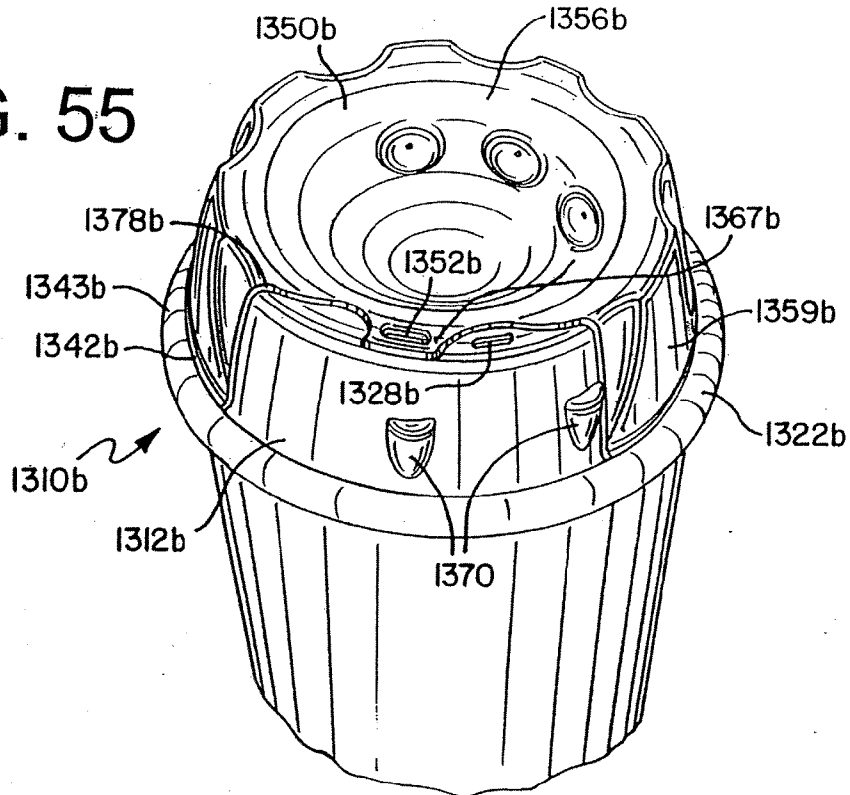

FIG. 56

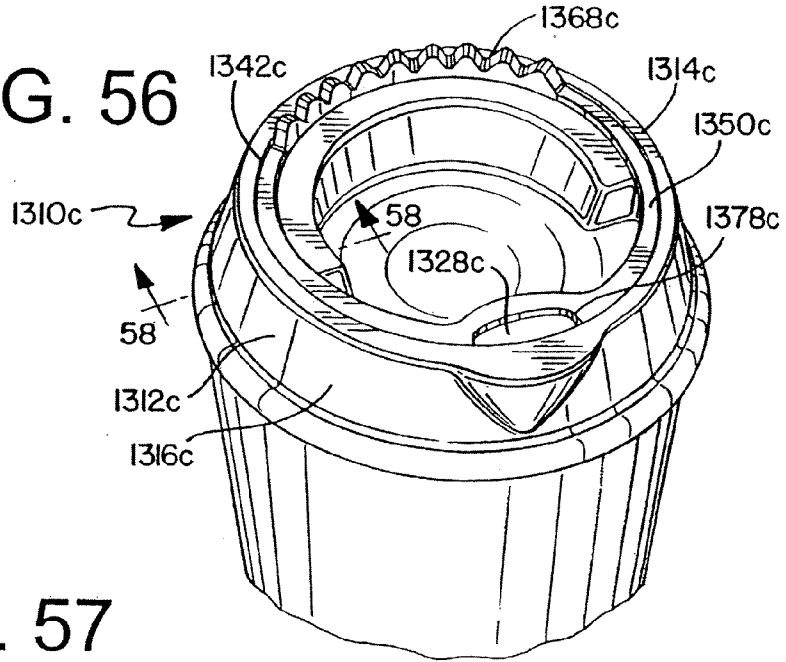

FIG. 57

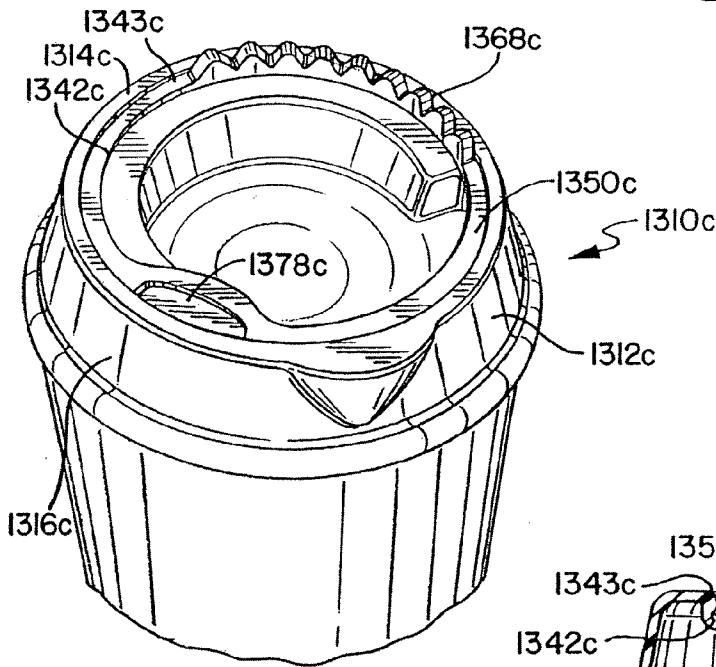
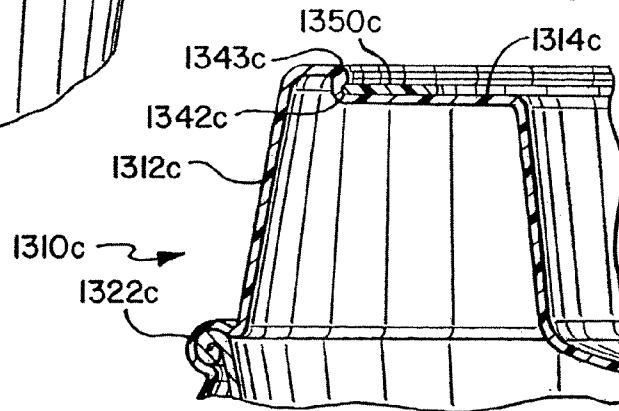
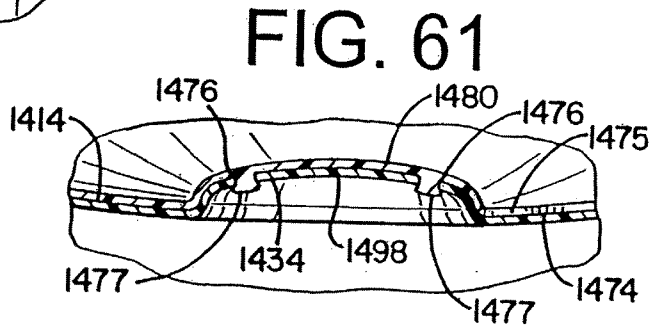
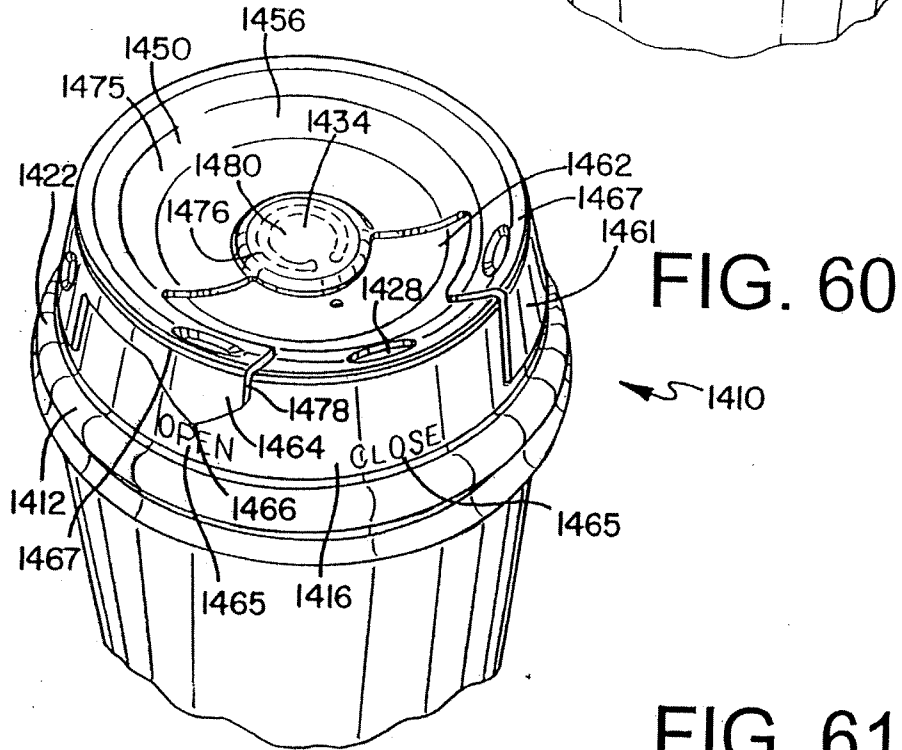
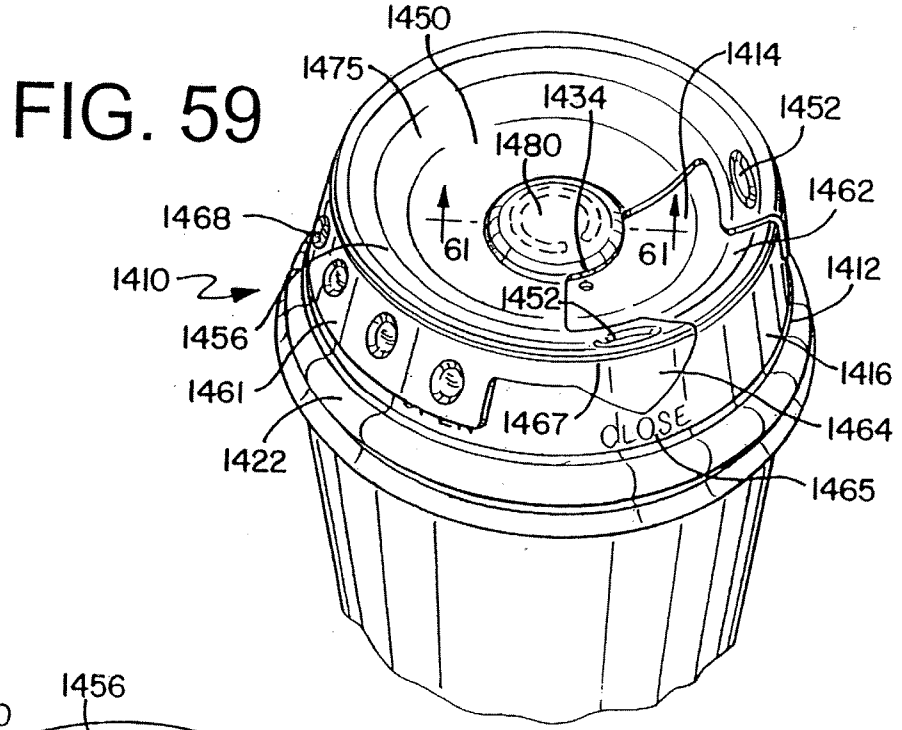

FIG. 58





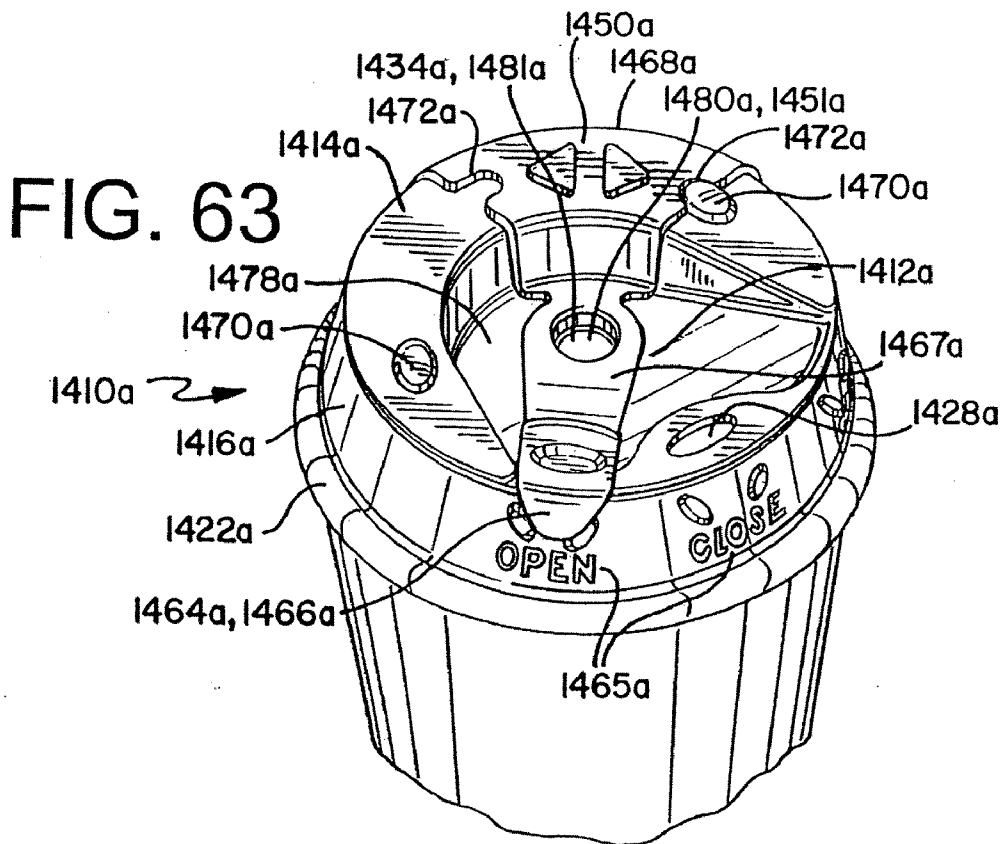
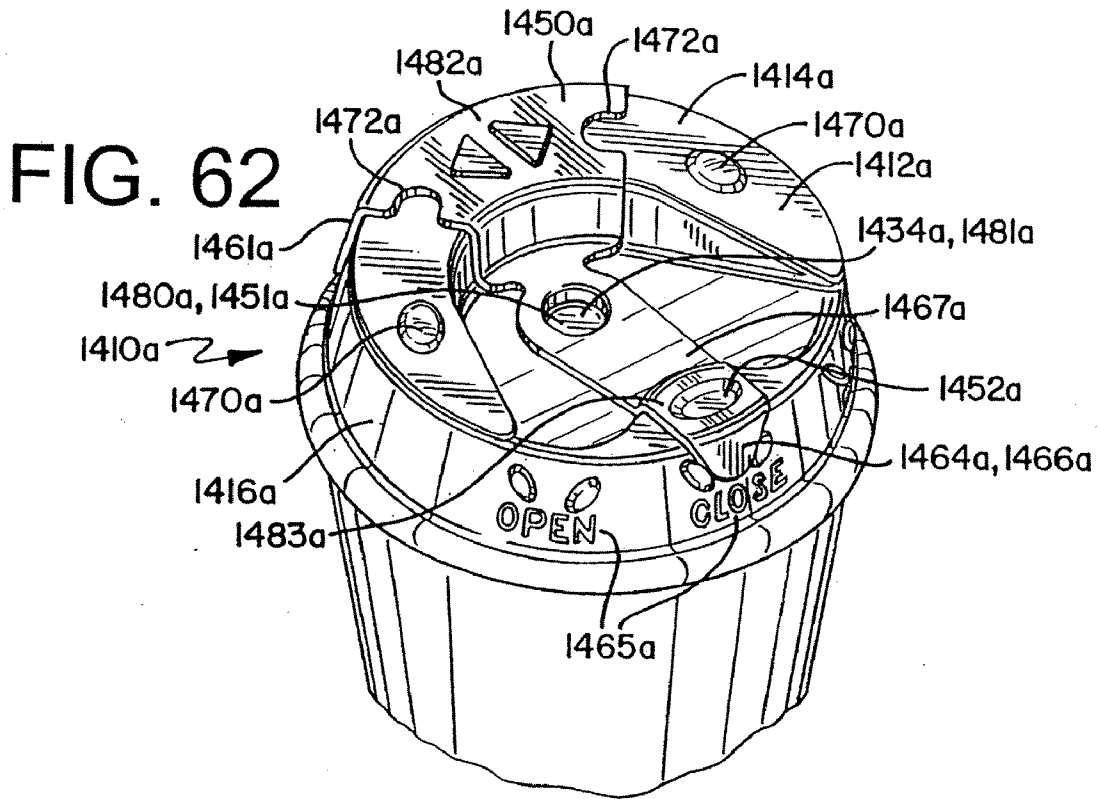

FIG. 64

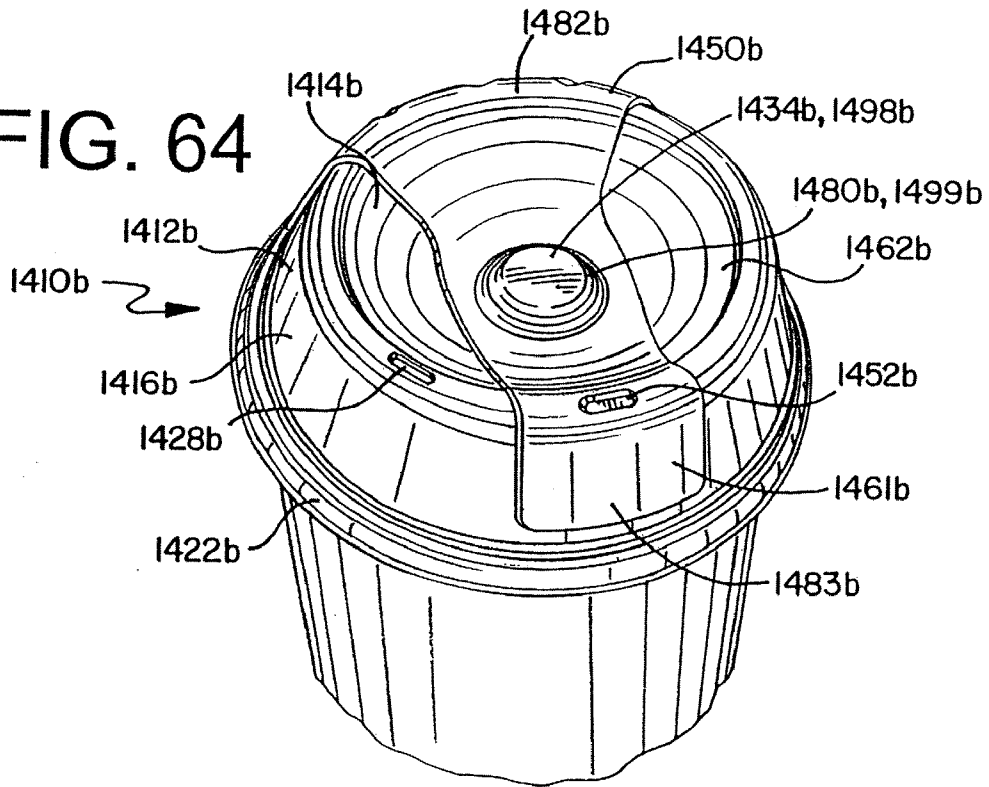
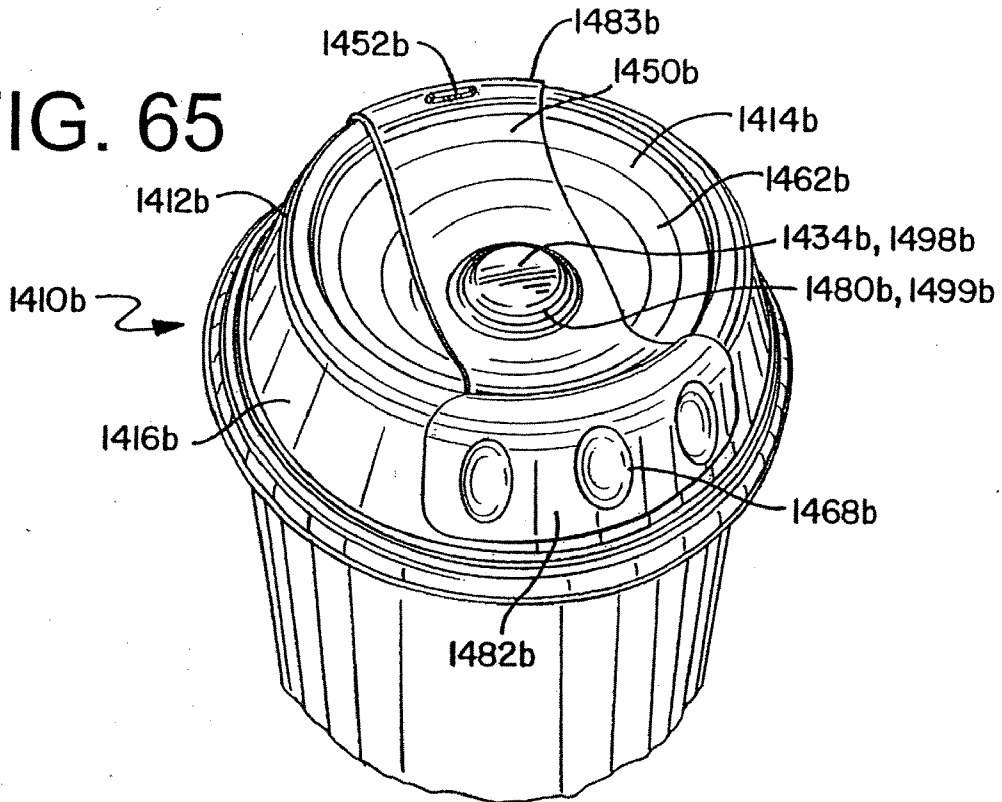

FIG. 65



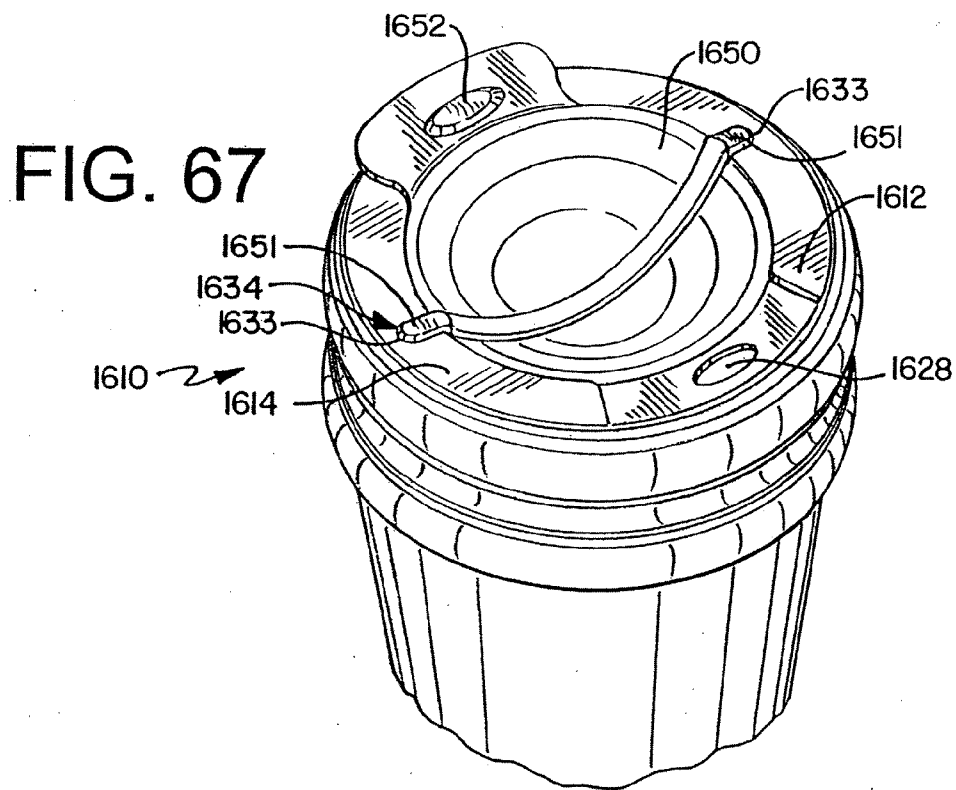
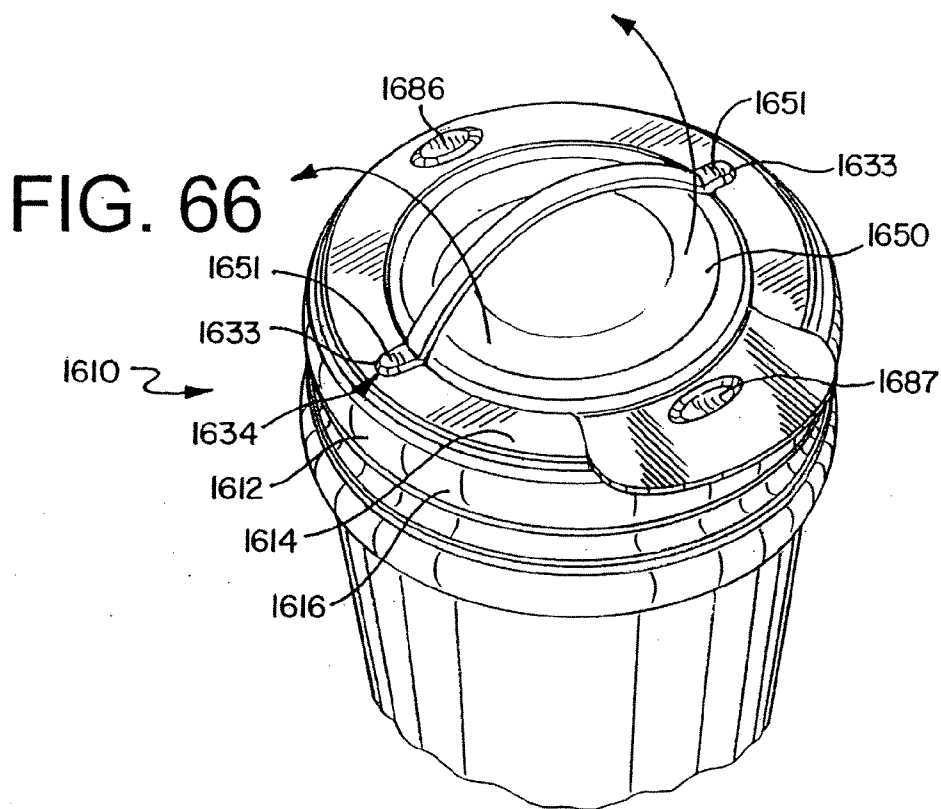



FIG. 68

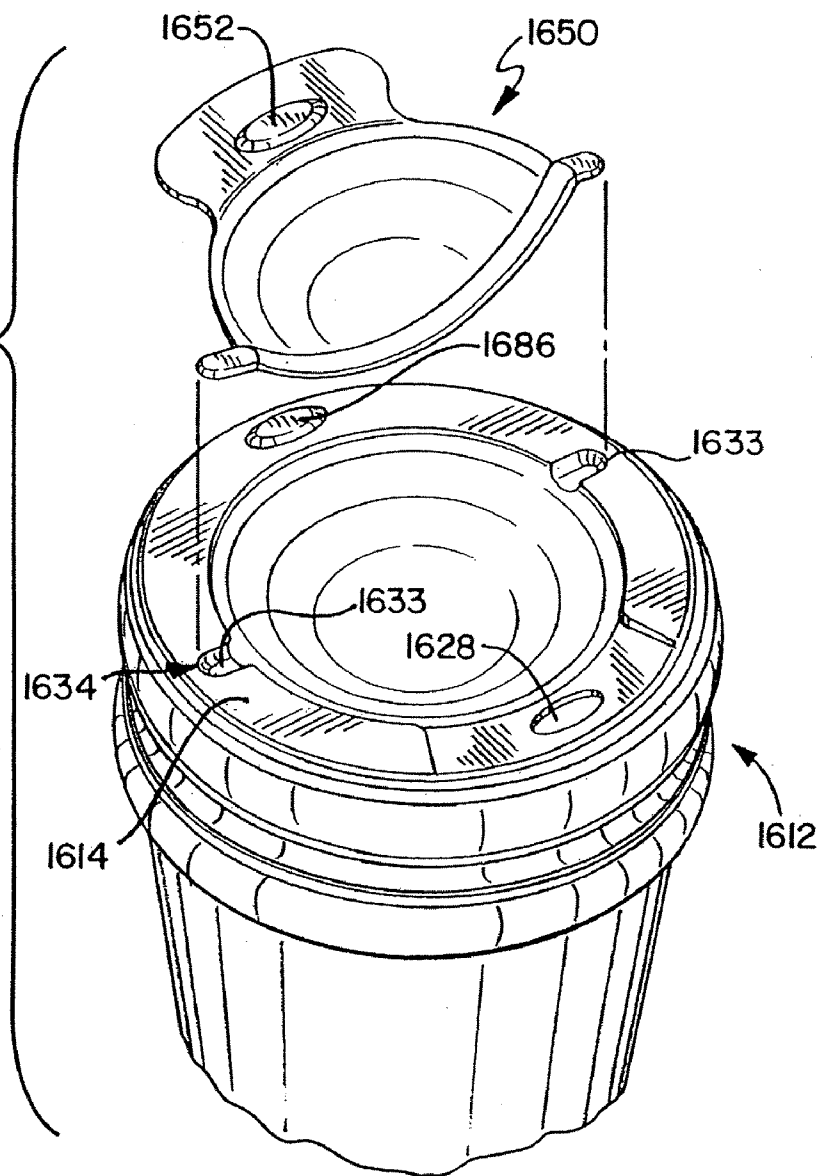

FIG. 69

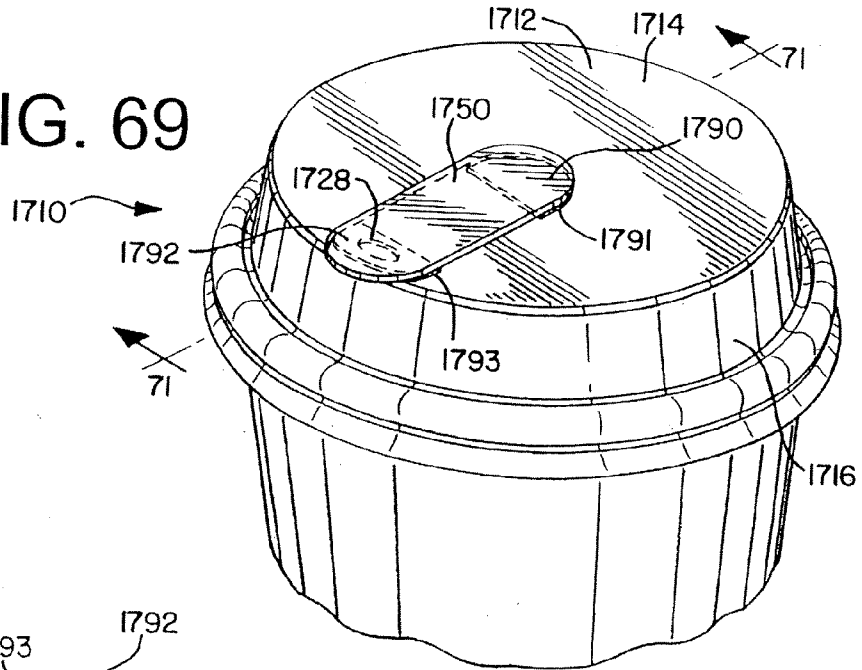

FIG. 70

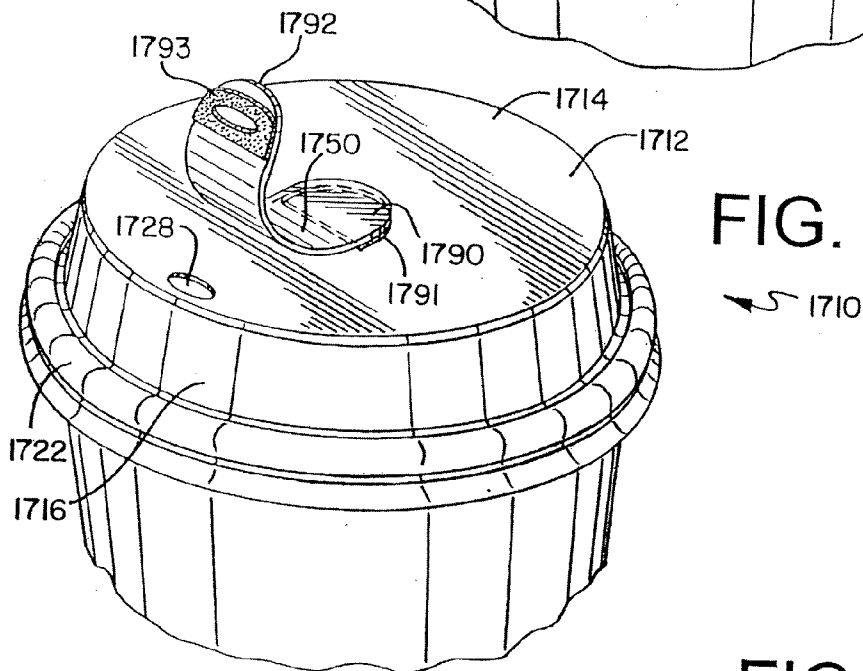

FIG. 71

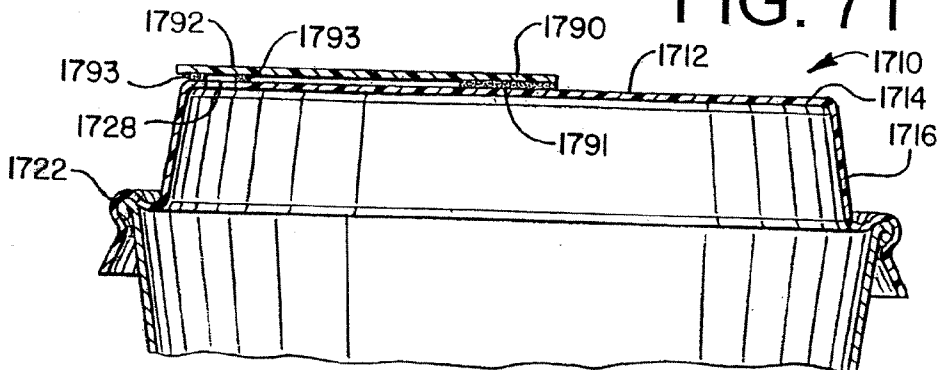

FIG. 72

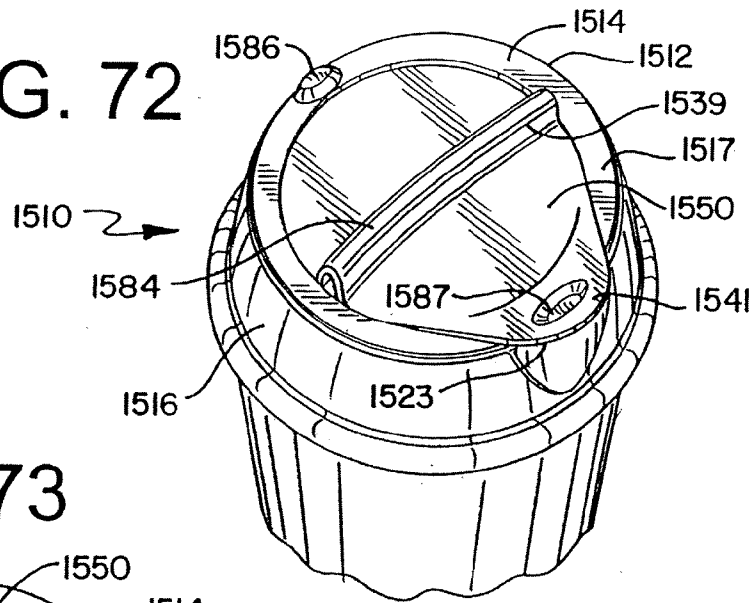

FIG. 73

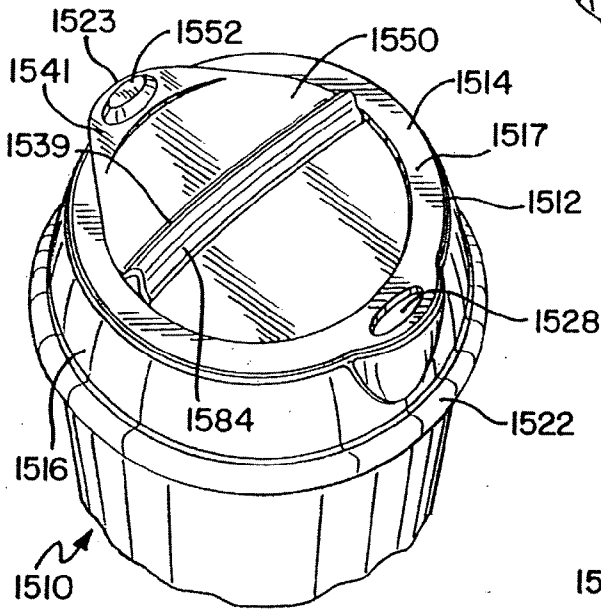

FIG. 74

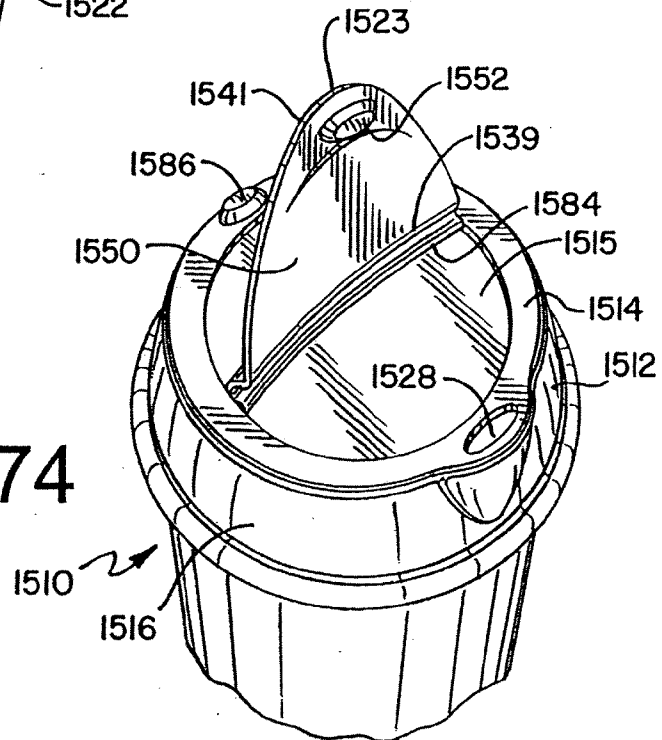

FIG. 75

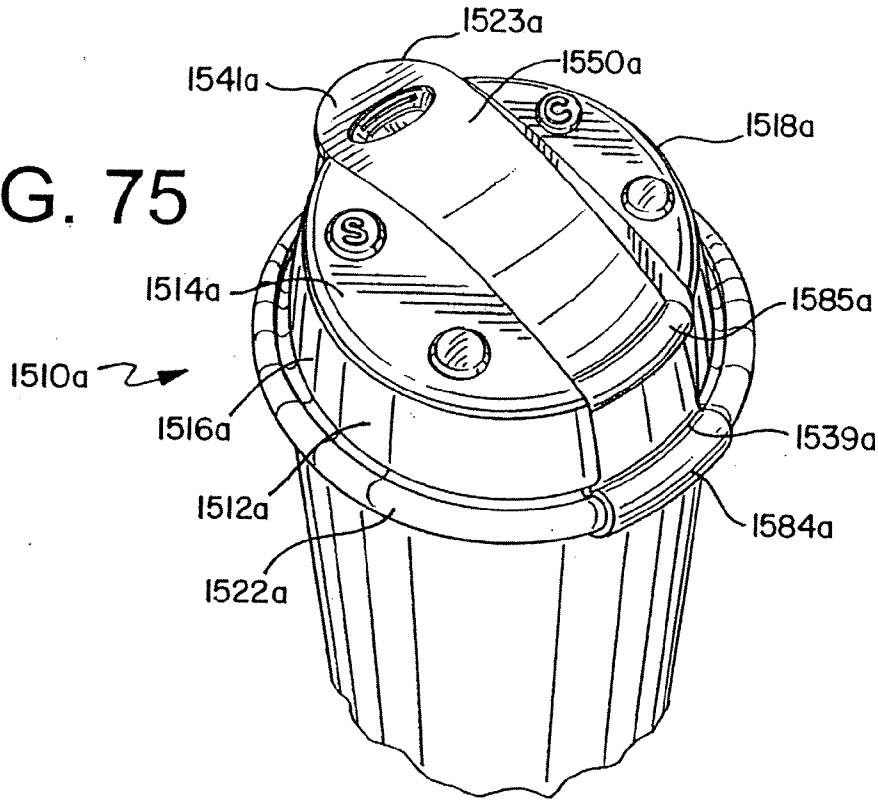

FIG. 76

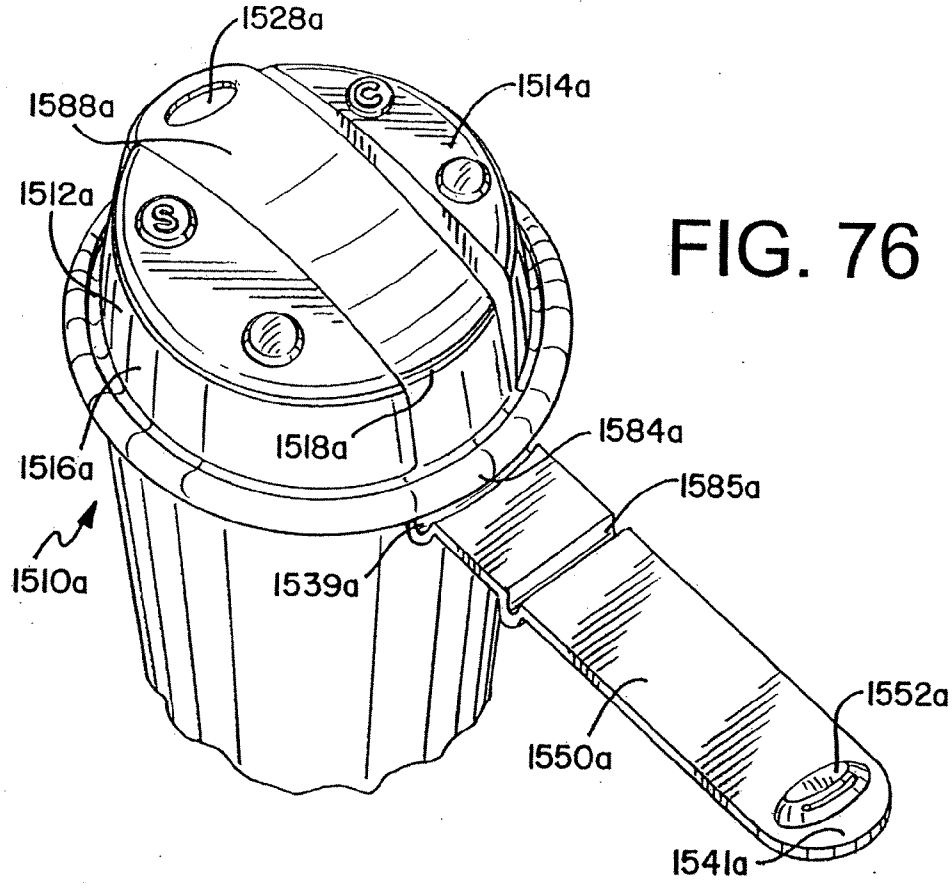

FIG. 77

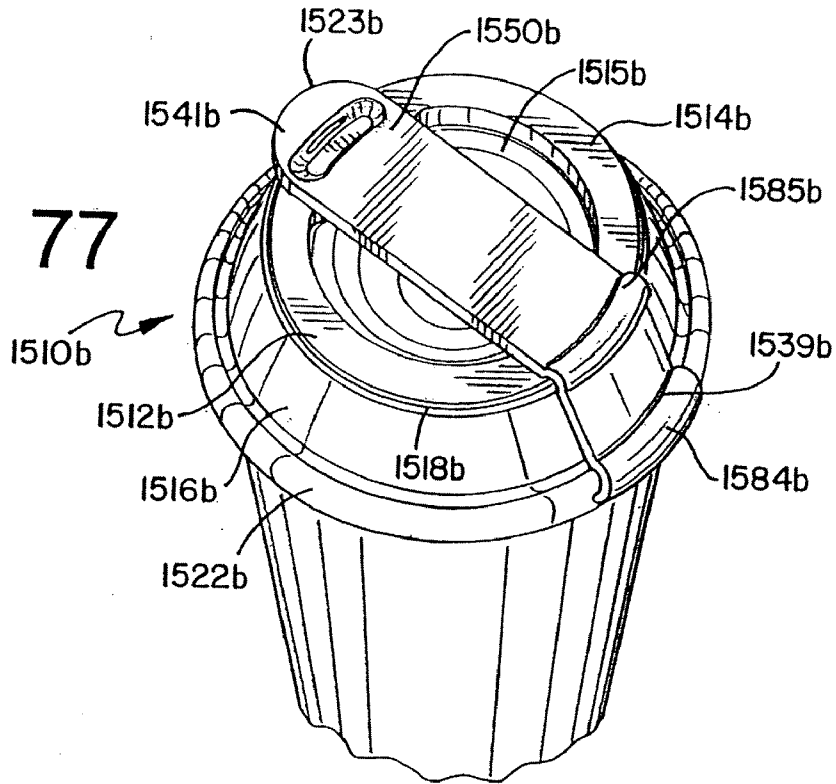

FIG. 78

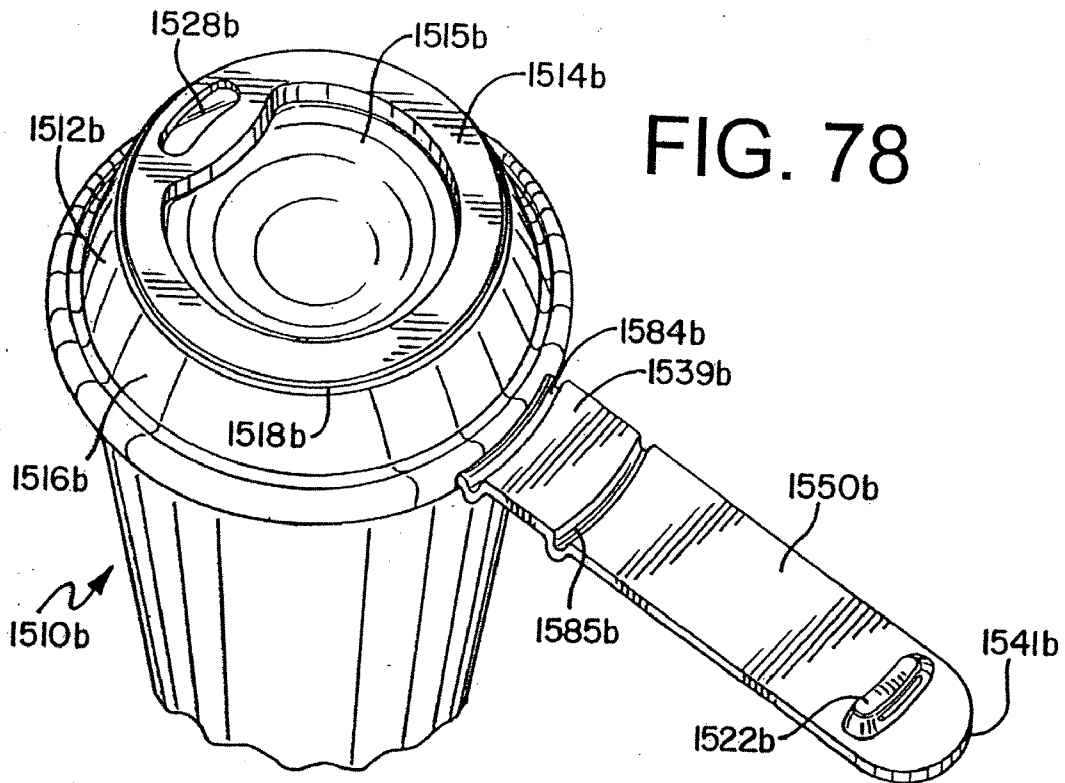

FIG. 79

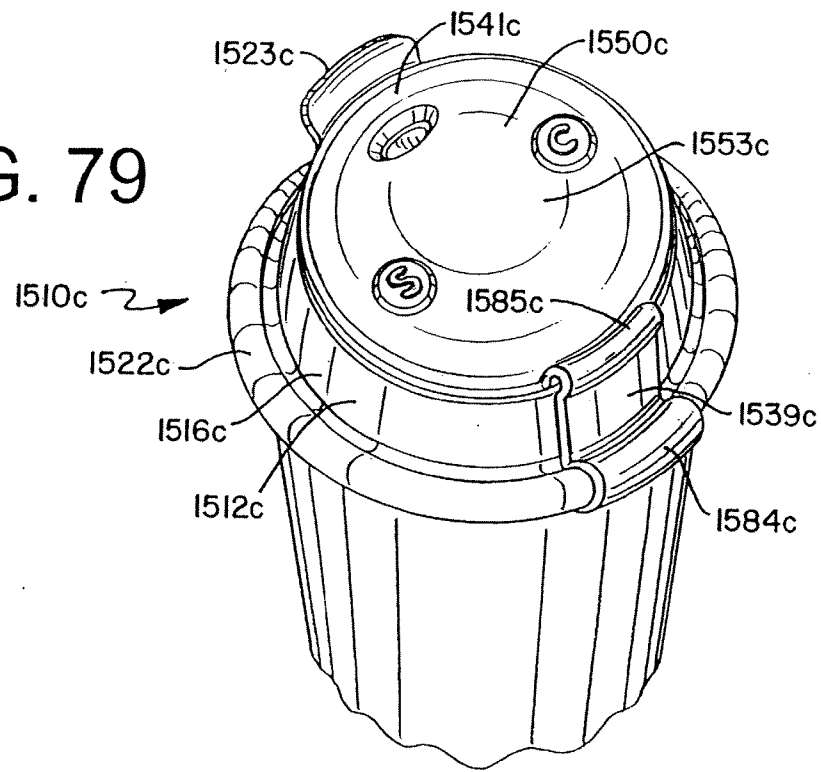

FIG. 80

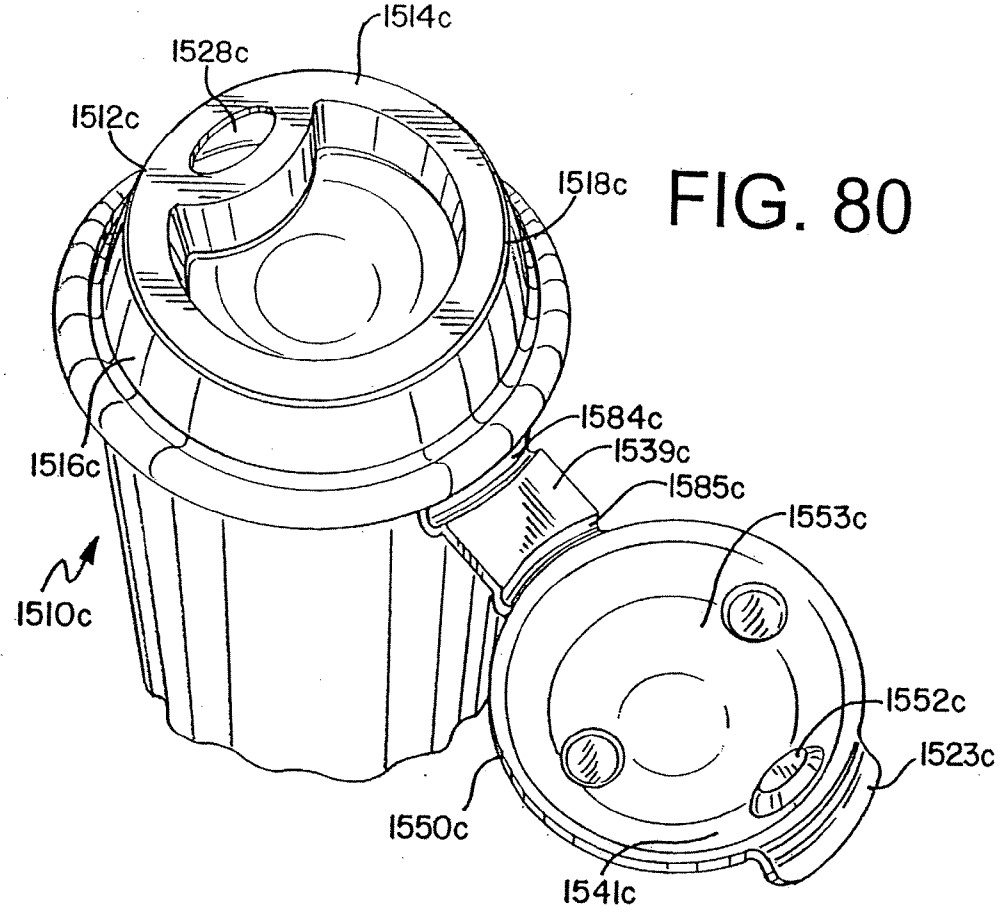

FIG. 81

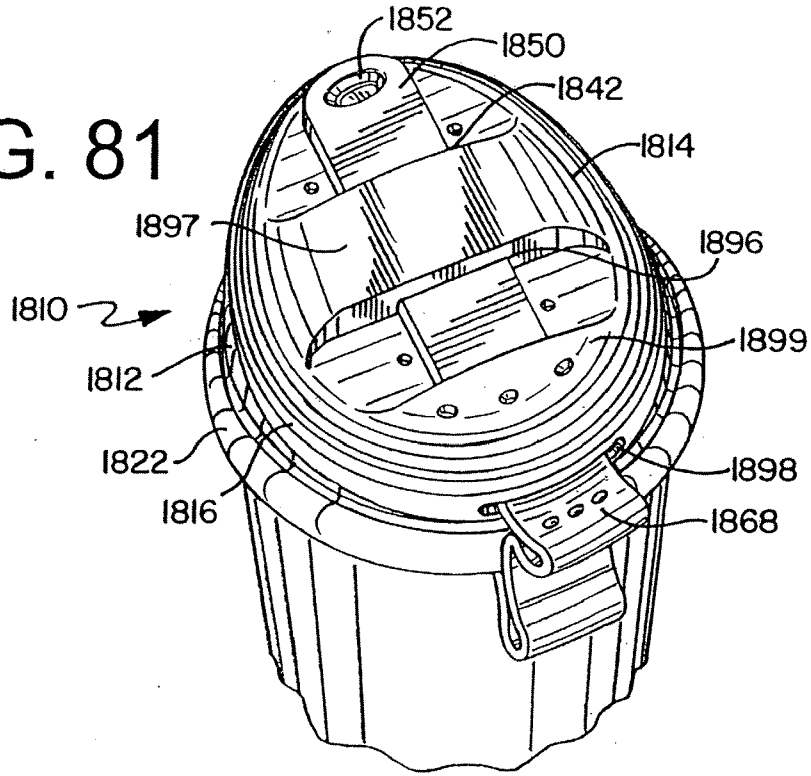

FIG. 82

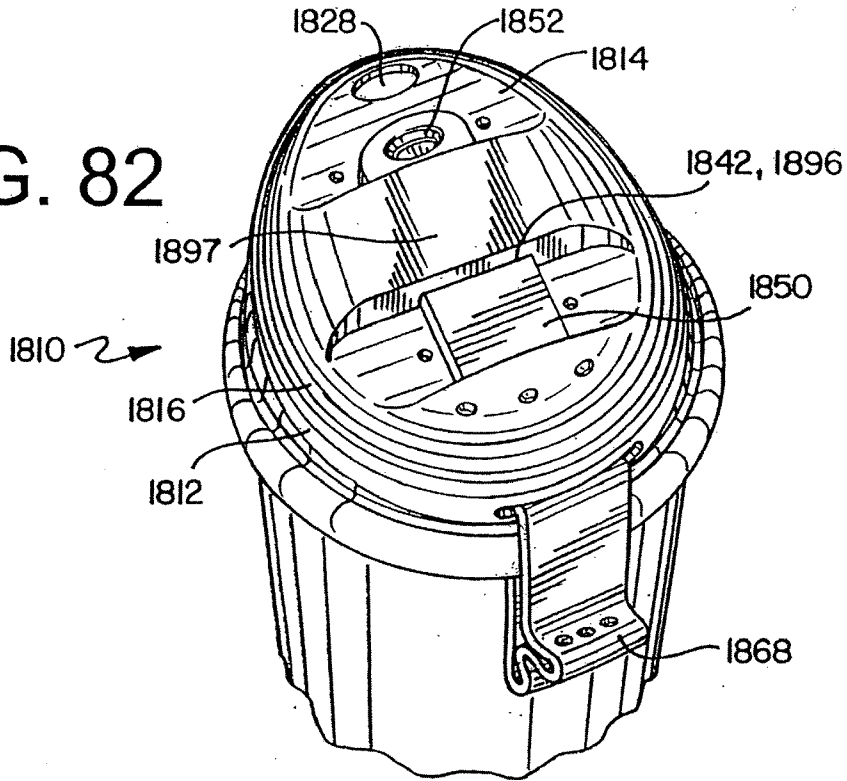





FIG. 86

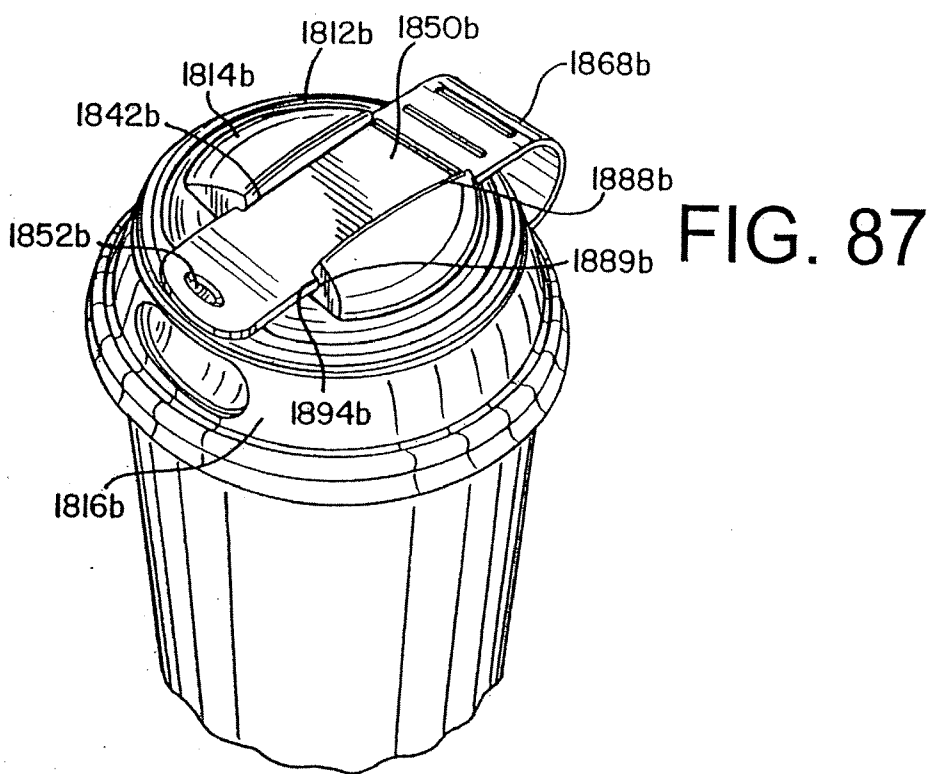
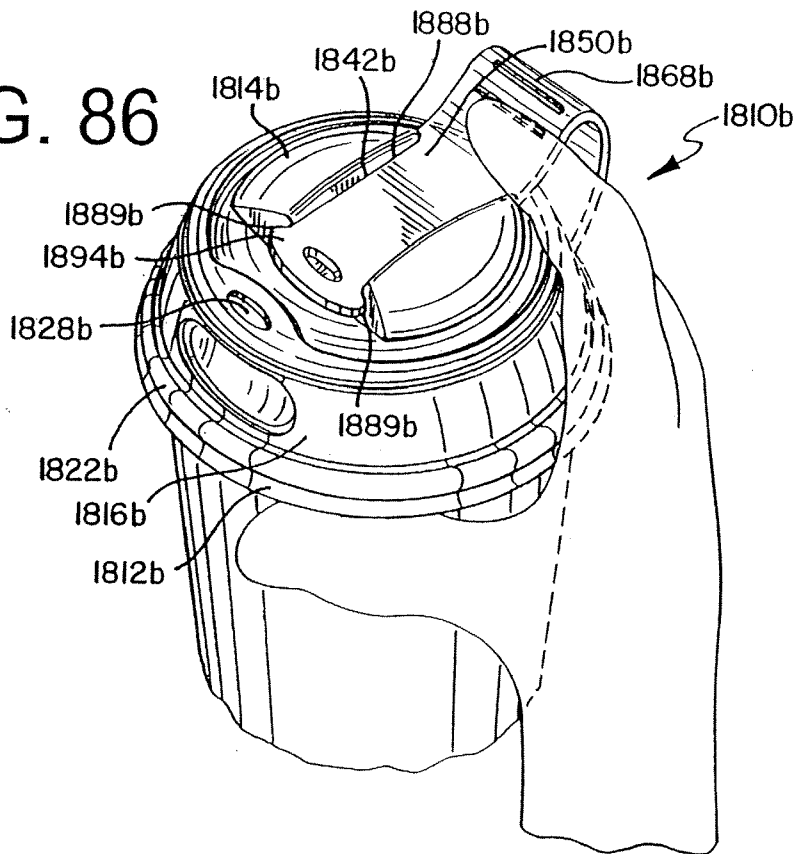

FIG. 87

FIG. 88

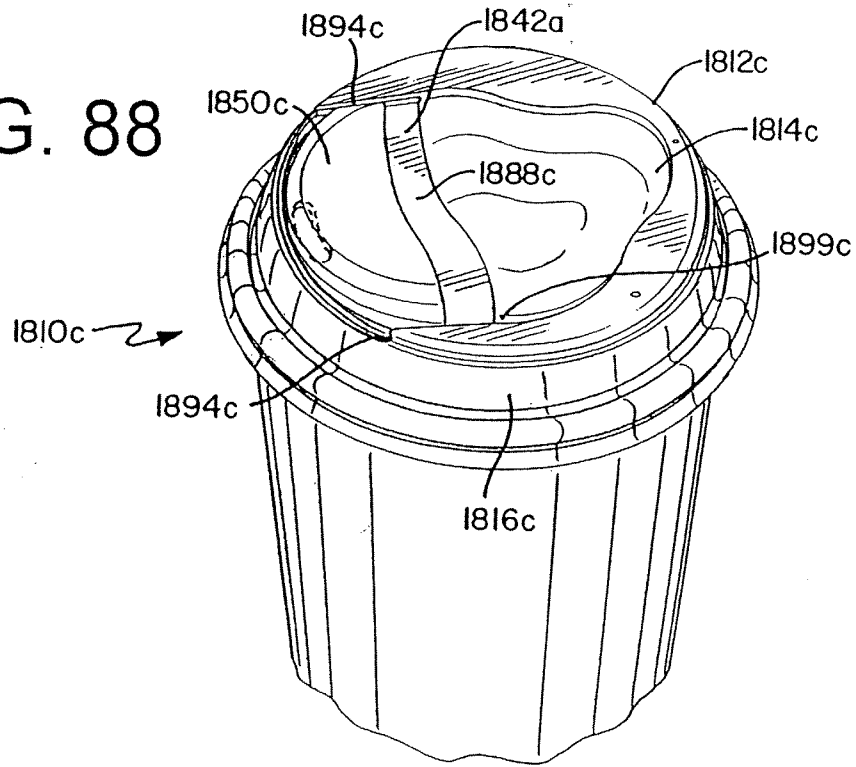

FIG. 89

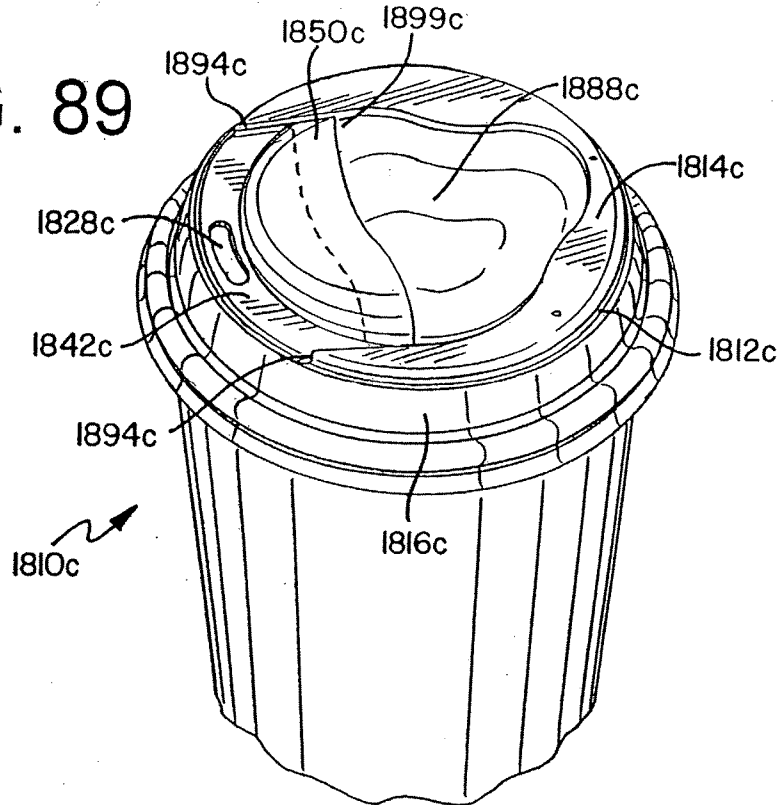

FIG. 90

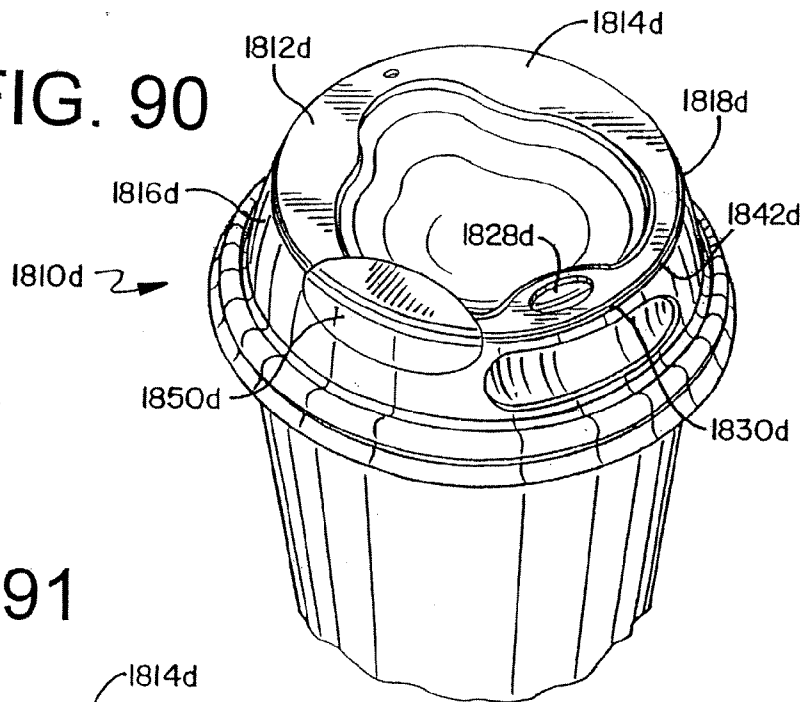

FIG. 91

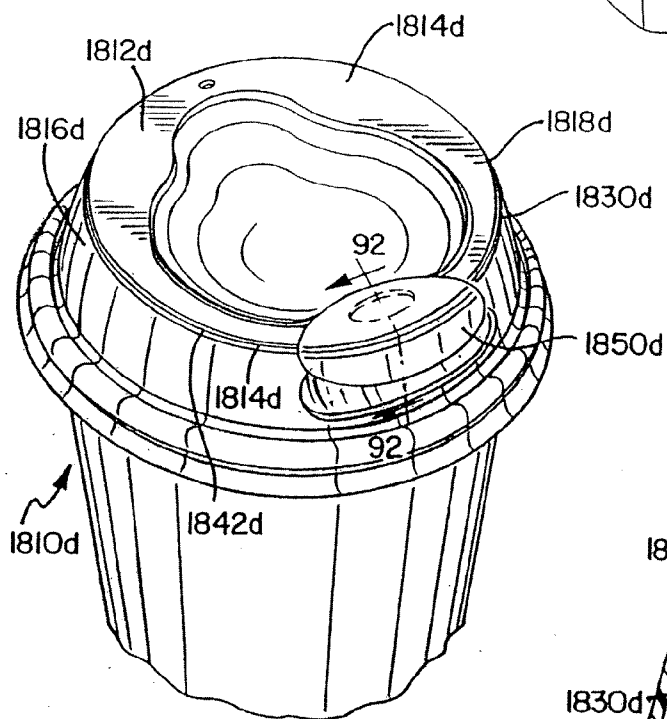

FIG. 92

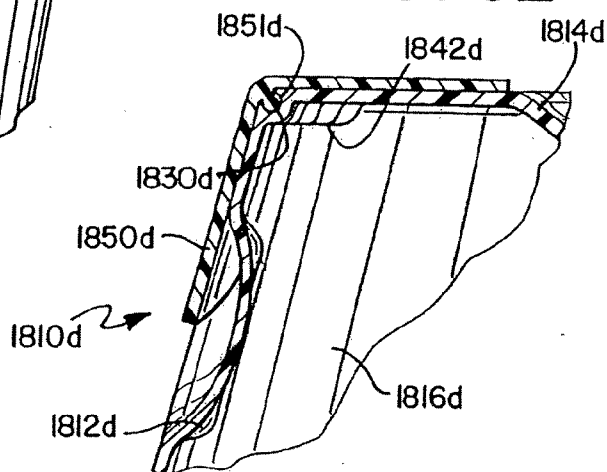

FIG. 93

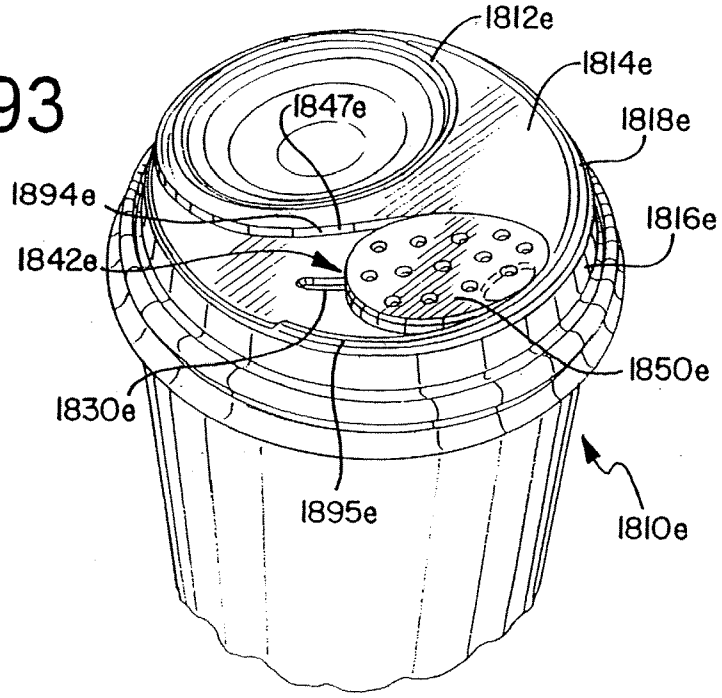

FIG. 94

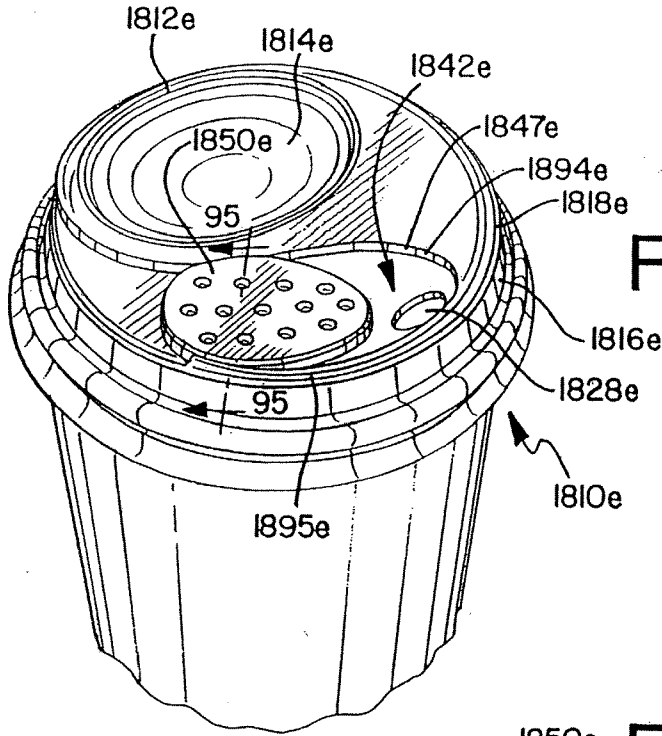
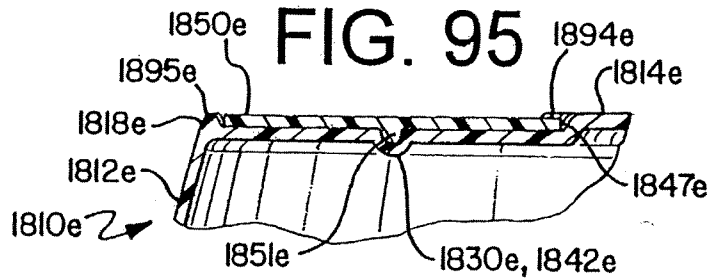

FIG. 95



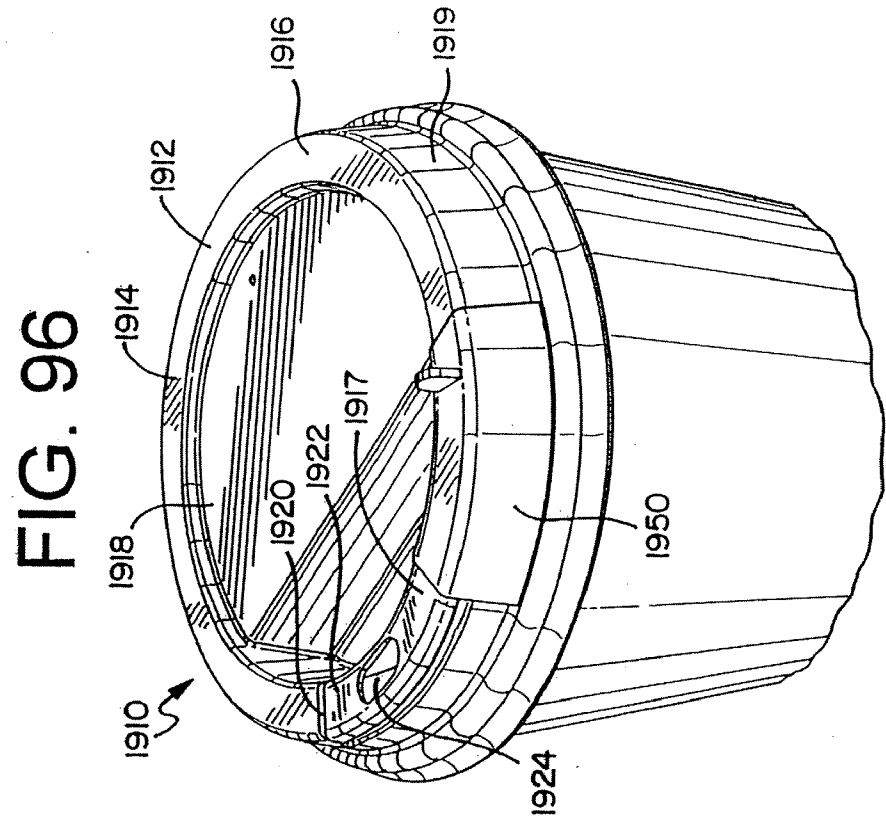
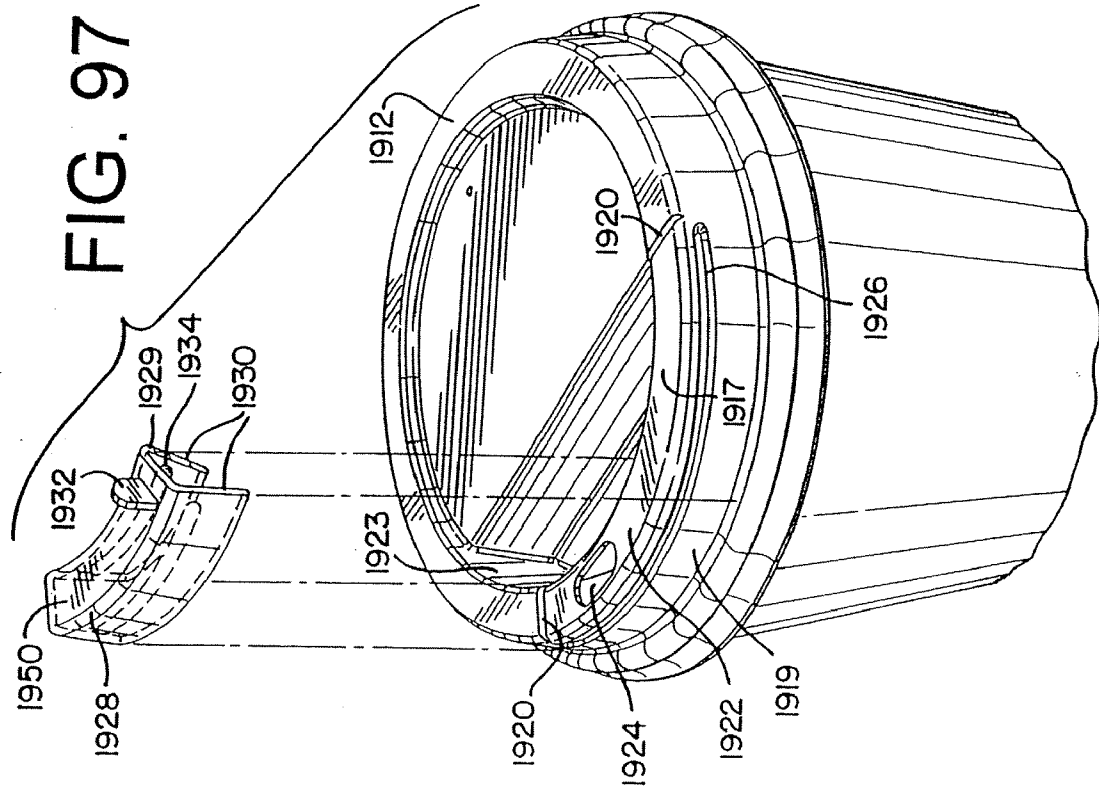

FIG. 98

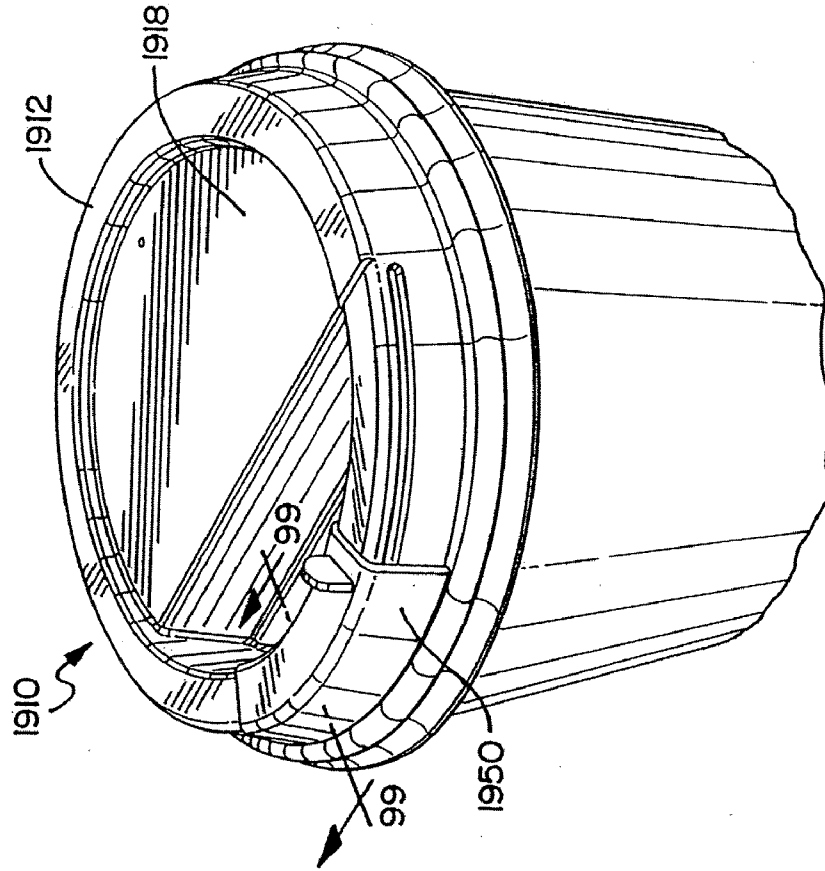
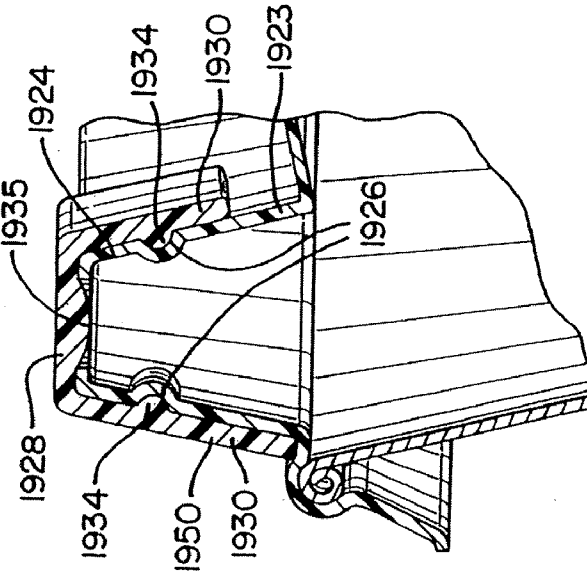

FIG. 99



## RECLOSABLE CONTAINER LID

### CROSS-REFERENCE TO RELATED APPLICATIONS

[0001] This is a Divisional Application from application Ser. No. 10/954,827 (filed Sep. 30, 2004), which is a Continuation-in-Part (CIP) Application from application Ser. No. 10/622,374 (filed on Jul. 18, 2003), issued as U.S. Pat. No. 7,246,715 on Jul. 24, 2007, which is a Continuation-in-Part (CIP) Application from application Ser. No. 09/923,763, (filed on Aug. 6, 2001), issued as U.S. Pat. No. 6,732,875 on May 11, 2004, which Applications are incorporated by reference and made a part hereof.

### FEDERALLY SPONSORED RESEARCH OR DEVELOPMENT

[0002] Not applicable.

### TECHNICAL FIELD

[0003] The present invention relates to a lid for a flowable substance container. More specifically, the present invention relates to a reclosable lid for use with a drink container.

### BACKGROUND OF THE INVENTION

[0004] Lids for containers are well-known in the beverage container industry. In general terms, lids for single-use or disposable containers have three main components: a top wall or surface, a mounting portion, and an opening. Typically, the mounting portion is adapted to engage an upper rim of the container to seal the lid on the container. The opening is adapted to permit the flow of the container contents through the lid.

[0005] Existing lid designs suffer from a number of problems including untimely spillage through the opening due to the lack of a reliable means for sealing the opening. The inability to effectively seal the opening can also result in a significant loss of heat from the container contents through the opening. To address these and other problems, a number of lid designs include a movable cover portion for the opening. However, most existing movable covers lack structural integrity and as a result, do not effectively seal the opening. Also, a number of movable covers are difficult to operate due to their complex design. In addition, a vast majority of movable covers interfere with a user consuming the container contents through the opening.

[0006] U.S. Pat. No. 4,579,245 to Narushko provides an example of a container lid with a movable closing flap. The lid has a raised segment that forms a channel, which is adapted to receive the closing flap. The closing flap is a curved piece that must be inserted into the channel. The closing flap is movable between an open position and a closed position. Because the movement of the closing flap is controlled by a series of notches, grooves, tabs and handles located on the channel and the closing flap, the closing flap is difficult to operate and the effectiveness of the lid is compromised.

[0007] Another example of a lid having a movable cover for the opening is disclosed in U.S. Pat. No. 4,790,444 to Terzi. There, the hood or lid has an opening formed from a depending spout that is inserted into the container opening. The cover has exterior dimensions equivalent to the lid and is placed over the lid. The cover has an opening that must be aligned with the spout and the lid opening to form the drink passageway. The cover has a plurality of sockets, which when prop-

erly aligned, seal the lid opening. The cover is supported on the lid by a series of intricate structures and an annular gasket. Due to its complex array of structures, the lid and cover are difficult to assemble and operate. Furthermore, the array of structures can inhibit the alignment of the lid opening and the cover opening negatively affecting the formation of the drink passageway.

[0008] Therefore, there is a definite need for a reclosable container lid that reliably seals the opening. In addition, there is a need for such a lid that is easy to operate and does not interfere with a user consuming the container contents through the opening.

[0009] The present invention is provided to solve these and other problems.

### SUMMARY OF THE INVENTION

[0010] The present invention relates to a reclosable lid for use with a flowable substance container. The lid has a first piece or cover, and a reclosable second piece or disk. The cover has a top wall and a side wall depending from the top wall. The side wall has a mounting portion for connecting the lid on the container. The cover includes an opening in the top wall, the opening adapted to permit the flow of the substance through the lid. The cover further includes a slot located in the top wall and a recessed portion located in both the top wall and the side wall.

[0011] The disk has at least one aperture, a post, and a projection. The aperture and the projection are each cooperatively dimensioned with the opening. The aperture is adapted to form a passageway when aligned with the opening. The post is adapted to be received by the slot in the cover. The disk is movable between a first and second position, wherein at least a portion of the projection is received in the opening in the first position and wherein the aperture is aligned with the opening in the second position. The disk has at least one well adapted to facilitate stacking the lids in a vertical configuration.

[0012] The cover includes at least one support member having a cavity extending radially inward from the side wall. The cavity of the support member forms a support ledge on an inner surface of the cover that is adapted to provide rotatable support to the disk. The disk is further supported by an internal edge that is formed on the inner surface by the recessed portion, which extends radially inward from the side wall.

[0013] The disk is movable between the first and second positions by a user engaging and actuating the post. While the disk is moved between the first and second positions, the disk is rotatably supported by the support ledge and the support edge.

[0014] In another preferred embodiment of the invention, the lid includes a cover and an overlay. The cover has a top wall and a side wall depending from the top wall. The side wall has a mounting portion for connecting the lid on the container. The lid includes an opening in the top wall, the opening adapted to permit the flow of the substance through the lid. The lid further includes a recessed portion located in both the top wall and the side wall.

[0015] The overlay has a top wall and a side wall depending from the top wall. The side wall has a mounting portion adapted to connect the overlay to the cover. Also, the overlay has a projection in the top wall and at least one aperture. In addition, the overlay has at least one gripping element adapted to facilitate rotational movement of the overlay.

**[0016]** The overlay and the disk are cooperatively dimensioned such that they are in rotational engagement when the overlay is positioned on the disk. The overlay is movable between a first position and a second position, wherein a portion of the projection is received in the opening in the first position and wherein the aperture is aligned with the opening in the overlay in the second position.

**[0017]** The overlay is movable between the first and second positions by a user engaging either the overlay or the gripping element. While the overlay is moved between the first and second positions, the overlay is rotatably supported by the engagement of the mounting portion of the cover and the mounting portion of the overlay.

**[0018]** According to another aspect of the invention, the lid has a tab extending radially outward from a mounting portion of the cover. The tab has a plurality of segments, including at least one sloped or angled segment. Preferably, the tab has curvilinear configuration and is integrally formed with the cover. The tab is adapted to ensure the proper assembly of the lid by fixing the position of the cover with respect to the rotatable element.

**[0019]** According to another aspect of the invention, the lid has a cover adapted to be attached to the container, the cover having a top wall having a generally annular upper level and a generally planar lower level, a side wall depending from the top wall, an opening in the upper level of the top wall, a slot in the lower level of the top wall, a position indicator, and a support member. The lid also has a moveable element rotatably mounted on the support member, the moveable element having an aperture and an actuator accessible through the slot.

**[0020]** According to another aspect of the invention, the lid has a cover adapted to be attached to the container, the cover having an opening, a slot, and a support member. The lid also has a moveable element, having a knob, an appendage, and an actuator accessible through the slot, pivotably mounted on the support member within an interior region of the cover such that the knob is received in the support member.

**[0021]** According to another aspect of the invention, the lid has a cover adapted to be attached to the container, the cover having an opening, a slot, a support member, and a stop. The lid also has a moveable element, having a top wall, a side wall depending from the top wall, an aperture, an actuator comprising a portion of the side wall, and a gripping element. The moveable element is rotatably mounted on the support member such that the actuator is accessible through the slot. The stop constrains rotation of the moveable element. The moveable element is moveable by manipulation of the actuator between a first position wherein the aperture is located to the left of the opening, a second position wherein the aperture is aligned with the opening, and a third position wherein the aperture is located to the right of the opening.

**[0022]** According to another aspect of the invention, the lid may have a position indicator to indicate when the lid is in an open position and a closed position. The position indicator may be located on one of the cover and the moveable element or a combination thereof.

**[0023]** According to another aspect of the invention, the lid has a cover adapted to be attached to the container, the cover having an opening and a track, and an overlay rotatably mounted on the track. The track is preferably an annular cusp and the overlay preferably has an annular flange interlocking with the annular cusp.

**[0024]** According to another aspect of the invention, the lid has a cover adapted to be attached to the container, the cover

having a hub and an opening. The lid also has an overlay having a connector, rotatably mounted on the hub. It is understood that the overlay can take various different forms.

**[0025]** According to another aspect of the invention, the lid has a cover adapted to be attached to the container. The cover has a top wall, a side wall, and an opening, and a moveable element tethered to the cover. The moveable element is moveable between a first position wherein the moveable element obstructs the opening, and a second position wherein the moveable element does not obstruct the opening.

**[0026]** According to another aspect of the invention, the lid has a cover having a top wall and a side wall depending from the top wall. The top wall also has a first notch and a second notch. The lid also has a moveable element having a first peg and a second peg. The first peg fits pivotably within the first notch and the second peg fits pivotably within the second notch. The moveable element is pivotable between open and closed positions.

**[0027]** According to another aspect of the invention, the lid has a cover having an opening. The lid also has a moveable element having a first segment permanently attached to the cover by a high-tack adhesive element, and a second segment having a low-tack adhesive element thereon. The moveable element is moveable between a first position wherein the second segment obstructs the opening, and a second position wherein the second segment does not obstruct the opening. The low-tack adhesive element is releasably attached to the cover in the first position.

**[0028]** According to another aspect of the invention, the lid has a cover adapted to be attached to the container. The cover has a track and an opening. A moveable element is slidably mounted on the track. The moveable element is movable by sliding along the track between a first position wherein the moveable element obstructs the opening, and a second position wherein the moveable element does not obstruct the opening.

**[0029]** Other features and advantages of the invention will be apparent from the following specification taken in conjunction with the following drawings.

#### BRIEF DESCRIPTION OF THE DRAWINGS

**[0030]** FIG. 1 is a perspective view of a reclosable lid of the present invention, showing a cover;

**[0031]** FIG. 2 is an end view of the cover of FIG. 1;

**[0032]** FIG. 3 is a perspective view of an interior cavity of the cover of FIG. 1;

**[0033]** FIG. 4 is a perspective view of a movable disk of the lid of FIG. 1;

**[0034]** FIG. 5 is a perspective view of an alternate embodiment of a lid of the present invention, showing the lid in an open position;

**[0035]** FIG. 6 is a perspective view of a cover of the lid of FIG. 5;

**[0036]** FIG. 7 is a perspective view of an overlay of the lid of FIG. 5;

**[0037]** FIG. 8 is a perspective view of the lid of FIG. 5, showing the lid in a closed position;

**[0038]** FIG. 9 is a perspective view of an alternate embodiment of a lid of the present invention, showing a tab extending from a cover of the lid;

**[0039]** FIG. 10 is top plan view of the lid of FIG. 9;

**[0040]** FIG. 11 is a partial cross-section of the lid taken along line 11-11 of FIG. 10, showing the tab;



[0041] FIG. 12 is a partial cross-section of the lid taken along line 11-11 of FIG. 10, showing an alternate tab;

[0042] FIG. 13 is a perspective view of an alternate embodiment of a lid of the present invention, showing an interior cavity of the lid;

[0043] FIG. 14 is a perspective view of an alternate embodiment of a rotatable element for a lid of the present invention;

[0044] FIG. 15 is a top plan view of an alternate embodiment of a lid of the present invention, showing a lid with a cover having an enlarged slot;

[0045] FIG. 16 is a perspective view of a rotatable element of the lid of FIG. 15, showing the element having a pair of apertures;

[0046] FIG. 17 is a perspective view of an alternate embodiment of a lid of the present invention;

[0047] FIG. 18 is a top plan view of the lid of FIG. 17;

[0048] FIG. 19 is a perspective view of an alternate embodiment of a lid of the present invention, showing a cover and a rotatable element;

[0049] FIG. 20 is an end view of the lid of FIG. 19, showing the cover;

[0050] FIG. 21A is a partial cross-sectional view of the lid of FIG. 19 taken along line 21-21, showing the lid in a closed position;

[0051] FIG. 21B is a partial cross-sectional view of the lid of FIG. 19 taken along line 21-21, showing the lid in an open position;

[0052] FIG. 22 is top plan view of the lid of FIG. 19, showing the rotatable element;

[0053] FIG. 23 is a perspective view of an alternate embodiment of the lid of the present invention, the lid shown in a closed position;

[0054] FIG. 24 is a top view of the lid of FIG. 23, the lid shown in a closed position;

[0055] FIG. 25 is a perspective view of a cover of the lid of FIG. 23;

[0056] FIG. 26 is a perspective view of a moveable element of the lid of FIG. 23;

[0057] FIG. 27 is a cross-sectional view of the lid of FIG. 23, taken along lines 27-27 of FIG. 24;

[0058] FIG. 28 is a perspective view of the lid of FIG. 23, the lid shown in an open position;

[0059] FIG. 29 is a perspective view of an alternate embodiment of the lid of the present invention, the lid shown in a closed position;

[0060] FIG. 30 is a top plan view of the lid of FIG. 29, the lid shown in a closed position;

[0061] FIG. 31 is a perspective view of a cover of the lid of FIG. 29;

[0062] FIG. 32 is a perspective view of a moveable element of the lid of FIG. 29;

[0063] FIG. 33 is a cross-sectional view of the lid of FIG. 23, taken along lines 33-33 of FIG. 30;

[0064] FIG. 34 is a top plan view of the lid of FIG. 29, the lid shown in a first open position;

[0065] FIG. 35 is a top plan view of the lid of FIG. 29, the lid shown in a second open position;

[0066] FIG. 36 is a perspective view of the lid of FIG. 29, the lid shown in the second open position, with the first open position indicated by broken lines;

[0067] FIG. 37 is a perspective view of an alternate embodiment of the lid of the present invention, the lid shown in a closed position, the position of a moveable element indicated by broken lines;

[0068] FIG. 38 is a top plan view of the lid of FIG. 37, the lid shown in the closed position, the position of the moveable element indicated by broken lines;

[0069] FIG. 39 is a perspective view of a cover of the lid of FIG. 37;

[0070] FIG. 40 is a perspective view of the moveable element of the lid of FIG. 37;

[0071] FIG. 41 is a cross-sectional view of the lid of FIG. 37, taken along lines 41-41 of FIG. 38;

[0072] FIG. 42 is a perspective view of the lid of FIG. 37, the lid shown in an open position;

[0073] FIG. 43 is a top plan view of the lid of FIG. 37, the lid shown in the open position, the position of the moveable element indicated by broken lines;

[0074] FIG. 44 is a perspective view of an alternate embodiment of the lid of the present invention, the lid shown in a closed position;

[0075] FIG. 45 is a perspective view of the lid of FIG. 44, the lid shown in an open position;

[0076] FIG. 46 is an exploded perspective view of the lid of FIG. 44, with a connection between the cover and moveable element shown with broken lines;

[0077] FIG. 47 is a partial cross-sectional view of the lid of FIG. 44, taken along lines 47-47 of FIG. 44;

[0078] FIG. 48 is a perspective view of an alternate embodiment of the lid of the present invention, the lid shown in a closed position;

[0079] FIG. 49 is a perspective view of the lid of FIG. 48, the lid shown in an open position;

[0080] FIG. 50 is an exploded view of a separated cover and overlay of the lid of FIG. 48, with connections between the cover and the overlay shown with broken lines;

[0081] FIG. 51 is a partial cross-sectional view of the lid of FIG. 48, taken along lines 51-51 of FIG. 48;

[0082] FIG. 52 is a perspective view of an alternate embodiment of the lid of the present invention, the lid shown in an open position;

[0083] FIG. 53 is a perspective view of the lid of FIG. 52, the lid shown in a closed position;

[0084] FIG. 54 is a perspective view of an alternate embodiment of the lid of the present invention, the lid shown in a closed position;

[0085] FIG. 55 is a perspective view of the lid of FIG. 54, the lid shown in an open position;

[0086] FIG. 56 is a perspective view of an alternate embodiment of the lid of the present invention, the lid shown in an open position;

[0087] FIG. 57 is a perspective view of the lid of FIG. 56, the lid shown in a closed position;

[0088] FIG. 58 is a broken cross-sectional view of the lid of FIG. 56, taken along lines 58-58 of FIG. 56;

[0089] FIG. 59 is a perspective view of an alternate embodiment of the lid of the present invention, the lid shown in a closed position;

[0090] FIG. 60 is a perspective view of the lid of FIG. 59, the lid shown in an open position;

[0091] FIG. 61 is a partial cross-sectional view of the lid of FIG. 59, taken along lines 61-61 of FIG. 59;

[0092] FIG. 62 is a perspective view of an alternate embodiment of the lid of the present invention, the lid shown in a closed position;

[0093] FIG. 63 is a perspective view of the lid of FIG. 62, the lid shown in an open position;

[0094] FIG. 64 is a perspective view of an alternate embodiment of the lid of the present invention, the lid shown in an open position;

[0095] FIG. 65 is a perspective view of the lid of FIG. 64, the lid shown in a closed position;

[0096] FIG. 66 is a perspective view of an alternate embodiment of the lid of the present invention, the lid shown in a closed position;

[0097] FIG. 67 is a perspective view of the lid of FIG. 66, the lid shown in an open position;

[0098] FIG. 68 is an exploded view of the lid of FIG. 66, with connections between the cover and moveable element shown with broken lines;

[0099] FIG. 69 is a perspective view of an alternate embodiment of the lid of the present invention, the lid shown in a closed position;

[0100] FIG. 70 is a perspective view of the lid of FIG. 69, the lid shown in an open position;

[0101] FIG. 71 is a partial cross-sectional view of the lid of FIG. 69, taken along lines 71-71 of FIG. 69;

[0102] FIG. 72 is a perspective view of an alternate embodiment of the lid of the present invention, the lid shown in a closed position;

[0103] FIG. 73 is a perspective view of the lid of FIG. 72, the lid shown in an open position;

[0104] FIG. 74 is a perspective view of the lid of FIG. 72, the lid shown in a position half-way between the open position and the closed position;

[0105] FIG. 75 is a perspective view of an alternate embodiment of the lid of the present invention, the lid shown in a closed position;

[0106] FIG. 76 is a perspective view of the lid of FIG. 75, the lid shown in an open position;

[0107] FIG. 77 is a perspective view of an alternate embodiment of the lid of the present invention, the lid shown in a closed position;

[0108] FIG. 78 is a perspective view of the lid of FIG. 77, the lid shown in an open position;

[0109] FIG. 79 is a perspective view of an alternate embodiment of the lid of the present invention, the lid shown in a closed position;

[0110] FIG. 80 is a perspective view of the lid of FIG. 79, the lid shown in an open position;

[0111] FIG. 81 is a perspective view of an alternate embodiment of the lid of the present invention, the lid shown in a closed position;

[0112] FIG. 82 is a perspective view of the lid of FIG. 81, the lid shown in an open position;

[0113] FIG. 83 is a perspective view of an alternate embodiment of the lid of the present invention, the lid shown in a closed position;

[0114] FIG. 84 is a perspective view of the lid of FIG. 83, the lid shown in an open position;

[0115] FIG. 85 is a partial cross-section view of the lid of FIG. 83, taken along lines 85-85 in FIG. 84;

[0116] FIG. 86 is a perspective view of an alternate embodiment of the lid of the present invention, the lid shown in an open position;

[0117] FIG. 87 is a perspective view of the lid of FIG. 86, the lid shown in a closed position;

[0118] FIG. 88 is a perspective view of an alternate embodiment of the lid of the present invention, the lid shown in a closed position;

[0119] FIG. 89 is a perspective view of the lid of FIG. 88, the lid shown in an open position;

[0120] FIG. 90 is a perspective view of an alternate embodiment of the lid of the present invention, the lid shown in an open position;

[0121] FIG. 91 is a perspective view of the lid of FIG. 90, the lid shown in a closed position;

[0122] FIG. 92 is a partial cross-section view of the lid of FIG. 90, taken along lines 92-92 of FIG. 91;

[0123] FIG. 93 is a perspective view of an alternate embodiment of the lid of the present invention, the lid shown in a closed position;

[0124] FIG. 94 is a perspective view of the lid of FIG. 93, the lid shown in an open position;

[0125] FIG. 95 is a partial cross-section view of the lid of FIG. 93, taken along lines 95-95 of FIG. 94;

[0126] FIG. 96 is a perspective view of an alternate embodiment of the lid of the present invention, the lid shown in an open position;

[0127] FIG. 97 is an exploded perspective view of the lid of FIG. 96;

[0128] FIG. 98 is a perspective view of the lid of FIG. 96, the lid shown in a closed position; and

[0129] FIG. 99 is a partial cross-sectional view of the lid of FIG. 96, taken along lines 99-99 of FIG. 98.

#### DETAILED DESCRIPTION

[0130] While this invention is susceptible of embodiment in many different forms, there is shown in the drawings and will herein be described in detail preferred embodiments of the invention with the understanding that the present disclosure is to be considered as an exemplification of the principles of the invention and is not intended to limit the broad aspect of the invention to the embodiments illustrated.

[0131] A reclosable lid 10 for a container (not shown) of the present invention is illustrated in FIG. 1. The container has a central opening defining a volume that can be used to hold or contain a flowable substance, for example a liquid or a powder. The container and the lid 10 can be of either the disposable or extended use variety. FIG. 1 shows the lid 10 in the closed position wherein the lid 10 is sealed such that the flowable substance cannot flow through the lid 10. The lid 10 generally has a first piece or cover 12, and a movable second piece or disk 50 (positioned underneath cover 12 in FIG. 1).

[0132] The cover 12 of the lid 10 is adapted to span the opening in the upper portion of the container that is generally defined by an upper rim or edge of the container. For illustrative purposes, the container could be a coffee cup having an opening defined by the rim of the cup.

[0133] The cover 12 has an annular top wall 14 and a side wall 16 depending from a peripheral edge 18 of the top wall 14. Although the top wall 14 is shown as having a generally flat upper surface 14a, the upper surface 14a can be curved or angled. The side wall 16 has a side wall surface 16a and a lower edge 20. The side wall surface 16a can be curved or generally flat. The overall shape of the cover 12 is generally frustoconical, however, the cover 12 can have a number of other configurations.

[0134] A mounting portion 22 depends from the lower edge 20 of the side wall 16. The mounting portion 22 includes a generally annular flange 24 and a generally annular skirt 26. The mounting portion 22 is adapted for connecting the lid 10 to the container in a manner that seals the lid 10 on the container. Thus, the mounting portion 22 prevents leakage of

the container contents between the lid 10 and the container when the lid 10 is positioned on the container. In a preferred embodiment, the mounting portion 22 is integral with the side wall 6.

[0135] An aperture or drink opening 28 is located preferably in the top wall 14. Alternatively, the drink opening is located in the side wall 16. The opening 28 is adapted to permit the passage or flow of the flowable contents held by the container through the cover 12. The opening 28 has an edge 29 that defines the shape of the opening 28. Although shown in FIG. 1 as having an obround shape, the opening 28 can have a variety of shapes, including but not limited to circular, square, or rectangular. In the closed lid position shown in FIG. 1, at least a portion of a projection 52 of the disk 50 is received by or positioned in the opening 28. Alternatively, the disk 50 has a generally planar surface that is aligned with a surface of the cover 12 proximate the opening 28 in a surface-to-surface engagement such that the opening 28 is sealed. These aspects will be described below in greater detail.

[0136] A slot or channel 30 is located preferably in the top wall 14. The slot 30 has an edge 32 that defines the shape of the slot 30. Although shown in FIG. 1 as having an obround shape, the slot 30 can have a variety of shapes, including but not limited to circular, square, or rectangular. A post 54 extends from the movable disk 50. The slot 30 is adapted to receive at least a portion of the post 54 extending through at least a portion of the slot 30. Described in a different manner, at least a portion of the post 54 extends past the top wall surface 14a. This aspect will also be described below in greater detail.

[0137] Referring to FIGS. 1 and 2, the cover 12 further comprises at least one support member 34. The support member 34 has a peripheral edge 44 that defines the shape of the support member 34. The peripheral edge 44 has an upper edge 44a and a lower edge 44b. The peripheral edge 44 can have a variety of shapes, including the linear shape of the upper edge 44a and the serrated shape of the lower edge 44b. A cavity 46 is recessed from the peripheral edge 44. Described in a different manner, the cavity 46 extends radially inward from the peripheral edge 44. As a result, at least a portion of the support member 34 extends radially inward past an inner surface of the side wall 16. The dimensions and configurations of the support member 34 and the cavity 46 can vary with design parameters, including but not limited to the overall size of the cover 12 and/or the size of the movable second piece 50. The position of the support member 34 can also vary along the height of the side wall 16. For example, the support member 34 can be positioned proximate the peripheral edge 18, or the support member 34 can be positioned closer to the mounting portion 22.

[0138] FIG. 3 shows an interior cavity of the lid 12. At least one internal support ledge 102 is positioned on an internal surface 100 of the cover 12. The support ledge 102 is formed from the material defining the cavity 46 of the support member 34 which extends radially inward from the side wall 16. Accordingly, the material that forms the cavity 46 also forms the internal support ledge 102. The support ledge 102 has an upper edge 102a. Although shown having an elongated configuration, the dimensions and configurations of the support ledge 102 can vary depending upon the configuration of the support member 34 and the degree to which the support member 34 extends radially inward. The role of the support ledge 102 is fully described below.

[0139] As shown in FIG. 1, a center portion 36 is positioned radially inward from an inner edge 38 of the top wall 14. Preferably, the center portion 36 is recessed such that the center portion 36 has a curvilinear configuration when viewed in cross-section. The degree of recess or curvature of the center portion 36 can vary with the design parameters of the lid 10. Alternatively, the center portion 36 is in planar alignment with the top wall 14. In this configuration, the center portion 36 is not recessed.

[0140] Referring to FIGS. 1 and 2, the side wall 16 has a recessed portion 40, that is adapted to receive a lip of a person drinking from the container. An edge 42 of recessed portion 40 defines the configuration of the portion 40. In a preferred embodiment, the edge 42 has a generally straight base portion 43 that connects with a generally outwardly curved end segment 45 at each end. The recessed portion 40 is positioned radially inward from the side wall surface 16a. Although the recessed portion 40 is shown positioned on both the top wall 14 and the side wall 16, the recessed portion 40 can be limited to either the top wall 14 or the side wall 16. The shape and configuration of the recessed portion 40 can be varied to conform to numerous design parameters. Similarly, the degree of recess of the portion 40 can vary. For example, as shown in FIG. 1, the recessed portion 40 is deeper at base portion 43 and shallower at an end proximate the drink opening 28. Preferably, the recessed portion 40 is positioned about the drink opening 28. The top wall 14 and the side wall 16 cooperate to form a rounded edge 40b at the recessed portion 40.

[0141] Referring to FIG. 3, an internal support edge 104 is positioned in the internal surface 100 of the cover 12. The internal support edge 104 is formed from the material defining the recessed portion 40 which extends radially inward from the side wall 16. Accordingly, a portion of the material that forms the recessed portion 40 also forms the internal support edge 104. Preferably, the support edge 104 is positioned internal to and coincident with the rounded edge 40b of the recessed portion 40. The dimensions and configurations of the support edge 104 can vary depending upon the configuration of the recessed portion 40 and the degree to which the recessed portion 40 extends radially inward. The role of the support edge 104 is fully described below.

[0142] FIG. 4 shows the second piece or disk 50. The disk 50 has an outer edge 51 and a top wall 56 with a top wall surface 56a. The top wall 56 has an outer shoulder 58 and an inner shoulder 60. A side wall 59 depends from the outer shoulder 58. A center portion 62 extends radially inward from the inner shoulder 60. The center portion 62 comprises an annular side wall 64 and an inner portion 66. Preferably, the center portion 62 is recessed such that the center portion 62 has a curvilinear configuration when viewed in cross-section. The degree of recess or curvature of the center portion 62 can vary with the design parameters of the lid 10. Preferably, the degree of recess of the center portion 62 of the disk 50 is similar to the degree of recess of the center portion 36 of the cover 12. Alternatively, the inner portion 66 can be removed from the center portion 62 to reduce the weight and/or cost of the disk 50. In this configuration, the disk 50 has a ring-shaped configuration.

[0143] The projection 52 extends from a portion of the top wall 56. The projection 52 has a peripheral edge 68 that defines the shape of the projection 52. Preferably, the projection 52 is cooperatively dimensioned with the drink opening 28 such that at least a portion of the projection 52 is adapted

to be received by or positioned in the opening 28. The projection 52 has a projection surface 52a that is preferably sloped or angled to facilitate reception of the projection 52 by the opening 28. When the projection 52 is completely received in the opening 28, the opening 28 is sealed and the lid 10 is in the closed position shown in FIG. 1. In the closed position, a top portion 70 of the projection 52 extends past the recessed portion surface 40a.

[0144] The post 54 extends from a portion of the top wall 56. As shown in FIG. 4, the post 54 has opposed end walls 72, opposed side walls 74, and a top wall 76. The post 54 can have either a solid or hollow construction depending upon design parameters. At least a portion of the post 54 is received by the slot 30 and extends past the top wall surface 14a. Although the configuration and dimensions of the post 54 can vary according to design parameters of the lid 10, the post 54 must retain a configuration that permits it to be received by the slot 30. As shown in FIG. 4, the post 54 has a catenoid shape. The post 54 can have a gripping portion (not shown) that is adapted to facilitate the engagement of a user's fingers with the post 54. The gripping portion can be integral to the post 54 or it can be a separate element fastened to a portion of the post 54. For example, the gripping portion can be a plastic or rubber element fastened to the walls 72, 74.

[0145] As shown in FIG. 4, the disk 50 has at least one aperture 78. The aperture 78 has a peripheral edge 80 that defines the shape of the aperture 78. When the aperture 78 is aligned with the drink opening 28, a passageway is formed between the disk 50 and the cover 12 permitting the passage or flow of the flowable substance held by the container through the lid 10. Although the aperture 78 can have a variety of configurations and dimensions, the aperture 78 is preferably cooperatively dimensioned with the drink opening 28. In a preferred embodiment, the aperture 78 is positioned within the disk 50 recessed portion 84 and spaced a distance from the projection 52. In another preferred embodiment, the disk 50 includes two separate apertures 78.

[0146] The disk recessed portion 84 is preferably positioned about the projection 52 and the aperture 78. The degree of recess of the portion 84 can vary. An edge 86 of recessed portion 84 defines the configuration of the recessed portion 84. Although the recessed portion 84 is shown positioned on a portion of both the disk side wall 59 and the disk top wall 56, the recessed portion 84 can be limited to either the side wall 59 or the top wall 56. The recessed portion 84 is adapted to be received by an inner surface of the recessed portion 40 of the cover 12 when the disk 50 is positioned proximate the cover 12. Accordingly, the shape and configuration of the recessed portion 84 of the disk 50 is similar to the shape and configuration recessed portion 40 of the cover 12. The top wall 56 and the side wall 59 cooperate to form a rounded edge 84b at the recessed portion 84.

[0147] As further shown in FIG. 4, the disk 50 has at least one well 90 depending from a portion of the disk 50. The disk 50 has a first well 90a and a second well 90b in one preferred embodiment. The well 90 can depend from either the top wall 56 or the side wall 59, or therebetween. The well 90 has an outer edge 92 that defines the general shape of the well 90. A shoulder 94 depends from the outer edge 92. The shoulder 94 can have a curvilinear portion 94a and a generally linear portion 94b. An inner wall 96 depends from the shoulder 94. As shown in FIG. 4, the inner wall 96 has a generally annular configuration resulting in a generally tubular well configuration. However, the well 90 can have a variety of configura-

tions depending upon design parameters. Preferably, the well 90 has a bottom wall (not shown). Alternatively, the bottom wall is omitted, causing the well 90 to have a hollow, tubular configuration.

[0148] The first and second wells 90a, 90b can be positioned at various locations in the disk 50. Preferably, the first and second wells 90a, 90b are spaced a distance apart. The first well 90a and the second well 90b have the same dimensions and configurations. The depth or length of the well 90, as measured from a lower surface (not shown) of the disk 50 can vary. Similarly, the number and dimensions of the well 90, including the diameter, can vary with the numerous design parameters.

[0149] A drain hole (not shown) can be positioned in the disk 50, preferably in the center portion 62. When the flowable contents, i.e., liquid, accumulate between an interior surface of the cover 12 and the disk 50, the drain hole ensures the drainage of such contents into the container.

[0150] Referring to FIG. 1, the disk 50 and the cover 12 are cooperatively dimensioned such that the disk 50 can be positioned within an interior portion of the cover 12 to define an "assembled position." Referring to FIG. 3, in the assembled position, the disk 50 is rotatably supported by at least one support ledge 102 which is formed by the support member 34 extending radially inward as explained above. Specifically, a portion of the edge 51 of the disk 50 rotatably engages the support ledge 102. The disk 50 can be further rotatably supported by the interior edge 104 of the recessed portion 40. Although the cover 12 is shown in one preferred embodiment as having three support members 34 and three corresponding support ledges 102, the number and configuration of the members 34 and the ledges 102 can vary with the design parameters.

[0151] In the assembled position, the disk 50 is positioned proximate the cover 12 such that at least a portion of the post 54 is received by and extends through the slot 30. Described in a different manner, the disk 50 is positioned beneath the cover 12 such that the center portion 36 of the cover 12 is proximate the center portion 62 of the disk 50.

[0152] In the assembled position, the disk 50 is movable between a first position P1 and a second position P2. In the first position P1, as shown in FIG. 1, the projection 52 is received by the drink opening 28 such that the opening 28 is sealed and the lid 10 is closed. When the opening 28 is sealed, the edge 29 of the opening 28 is in frictional engagement with the projection 52. The top portion 70 of the projection 52 can extend past the edge 29 of the drink opening 28. This seal prevents the flow of the flowable substance in the container through the opening 28, enabling the container and lid 10 to be moved without risking spillage. Also, in the first position P1, the recessed portion 84 of the disk 50 is engaged with the recessed portion 40 of the cover 12. In addition, in the first position P1, the aperture 78 is misaligned or offset from the opening 28. Alternatively, the projection 52 and the opening 28 are in a snap fit engagement wherein each have sufficient structure to enable the snap fit engagement. Other cooperating structures can also be utilized.

[0153] In an alternate configuration of the disk 50, the projection 52 is omitted and the disk 50 has a generally planar surface (not shown). In the first position P1, the planar surface of the disk 50 is aligned with the opening 28 in a surface-to-surface engagement such that the opening 28 is sealed.

[0154] In the second position P2, a user engages the post 54 to rotate the disk 50 wherein the aperture 78 is aligned with

the drink opening 28 to form a passageway between the disk 50 and the cover 12 wherein the lid 10 is open. The passageway permits the passage or flow of the flowable substance held by the container through the lid 10. When the lid 10 is in the second position P2, at least a portion of the edge 80 of the aperture 78 is aligned with at least a portion of the edge 29 of the drink opening 28. Also, in the second position P2, the recessed portion 84 of the disk 50 is misaligned or offset from the recessed portion 40 of the cover 12. In addition, in the second position P2, the projection 52 is misaligned or offset from the opening 28. When the aperture 78 is partially aligned with the drink opening 28, the passageway remains but its dimensions are reduced. When the aperture 78 is completely misaligned with the drink opening 28, the passageway is eliminated. When the aperture 78 is completely misaligned with the drink opening 28 and the projection 52 is completely received in the opening 28, the opening 28 is sealed and the lid 10 is in the first position P1.

[0155] When the disk 50 is moved between the first position P1 and the second position P2, a portion of the edge 51 of the disk 50 remains in rotatable engagement with the support ledge 102. Accordingly, the support ledge 102 provides support to the disk 50 such that the disk 50 remains in the assembled position during movement between the first and second positions, P1, P2. When the cover 12 includes a plurality of support ledges 102, a greater portion of the edge 51 of the disk 50 remains in rotatable engagement with the support ledges 102. The edge 104 of the recessed portion 40 provides additional support for the disk 50 as it is moved between the first and second positions P1, P2.

[0156] A user can move the disk 50 between the first position P1 and the second position P2 by grasping and actuating or manipulating the post 54 between the first end 30a of the slot 30 and the second end 30b of the slot 30. Referring to FIG. 1, when the post 54 is proximate the first end 30a, the disk 50 is in the first position P1. Conversely, when the post 54 is proximate the second end 30b, the disk 50 is in the second position P2. The post 54 can be located in a number of positions between the first and second ends 30a, 30b and as a result, the projection 52 can be misaligned with the opening 28 to varying degrees.

[0157] The disk 50 can be rotated or moved a varying amount depending upon the numerous design parameters of the lid 10, including but not limited to the configuration and dimensions of the post 54 and the slot 30. Thus, the disk 50 assumes a number of positions and those positions depend upon the location of the post 54 relative to the slot 30. The movement of the disk 50 and the post 54 is ultimately constrained by the first and second ends 30a, 30b of the slot 30.

[0158] The lid 10 is adapted to permit a user to move the post 54 between the first and second positions P1, P2 with only one hand. This means that a user can hold the container and manipulate the post 54 with the same hand. This increases the flexibility and the commercial value of the lid 10.

[0159] As explained above, the disk 50 can have two separate apertures 78, wherein the apertures 78 are positioned about the projection 52. In this configuration, the disk 50 can be rotated in either a clockwise or counter-clockwise direction to move the disk 50 between the first position P1 and the second position P2. For example, rotating the disk 50 in the clockwise direction brings one aperture 78 into alignment with the opening 28, while rotating the disk in the counter-clockwise direction brings the other aperture 78 into alignment with the opening 28. This feature further increases the

flexibility and the commercial value of the lid 10. In such configuration, the length of the slot 30 is increased to allow for counterclockwise rotation of the disk 50 such that both apertures 78 can be aligned with the opening 28.

[0160] The lid 10 is adapted to be used without the disk 50. This means that the cover 12 is connected to a container but the disk 50 is omitted. In this configuration, there is no slot 30 and there is no structure to seal the opening 28 in the cover 12 and as a result, the flowable substance held by the container can pass through the lid 10. In this configuration, the recessed portion 40 remains positioned on both the top wall 14 and the side wall 16. However, the drink opening 28 can be positioned in either the top wall 14 or the side wall 16.

[0161] The opening 28 can be formed with a range of dimensions. At a minimum, the opening 28 should have dimensions sufficient to permit the passage of the flowable substance held by the container and receive the projection 52. The slot 30 can be formed with a range of dimensions. At a minimum, the slot 30 should have dimensions sufficient to receive and permit the movement of the post 54.

[0162] The opening 28 can be located at various positions along the top wall 14 depending upon design parameters. Similarly, the slot 30 can be located at various positions along the top wall 12. The opening 28 and the slot 30 are spaced a distance apart. Preferably, the opening 28 and the slot 30 are opposed on the top wall 12, meaning that they are positioned approximately 180 degrees apart. Alternatively, the post 54 is located on the sidewall 59 of the disk 50, and the slot 30 is cooperatively located on the sidewall 16 of the cover 12. In this configuration, a user moves the lid 10 between the first and second positions P1, P2 by engaging the post 54 that extends through the slot 30 positioned on the side wall 16 of the cover 12.

[0163] Although shown as having a generally circular shape, the lid 10, including the mounting portion 22, the flange 24 and the skirt 26, can have numerous configurations. For example, the lid 10 could have a rectangular, square, or oval shape. To ensure a leak-proof seal with the container, the shape of the mounting portion 22 should match the shape of the upper edge of the container so a cooperative sealing engagement can be achieved.

[0164] Alternatively, the mounting portion 22 could have a shape similar to the upper edge of the container, yet dissimilar from the shape of the side wall 16 and the top wall 14. For example, the mounting portion 22 could have an annular shape consistent with the container shape and the walls 14, 16 could have a non-annular shape.

[0165] Unlike prior art designs, the dimensions and the configuration of the opening 28 are not affected by the engagement and disengagement of the projection 52 as the disk 50 is moved between the first and second positions P1, P2. This attribute allows a user to repeatedly move the disk 50 between the first position and second position. Accordingly, the structural integrity and the durability of the lid 10 are increased.

[0166] The well 90 is adapted to aid in the storage and/or stacking of the disk 50 prior to the disk 50 and cover 12 being placed in the assembled position. Specifically, the well 90 is adapted to ensure that multiple disks 50 remain stacked in a stable vertical configuration prior to assembly of the lid 10. A portion of the well 90 of a first disk 50 engages a portion of well 90 of an adjacent second disk 50 positioned below the first disk 50. Accordingly, the well 90 should have a depth or length sufficient to permit it to engage a portion of the well 90

of the second disk 50. In an alternative configuration, the well 90 can be randomly placed wherein the well 90 of the first disk would rest on the top wall 56 of the second disk 50.

[0167] The well 90 is further adapted to aid in the storage and/or stacking of the assembled lid 10. Specifically, the well 90 is adapted to ensure that multiple lids 10 remain stacked in a stable vertical configuration. A portion of the well 90 of a first lid 10 engages a portion of an adjacent cover 12 of a second lid 10 positioned below the first lid 10. Accordingly, the well 90 should have a depth or length sufficient to permit it to engage a portion of the cover 12. The engagement of the well 90 with a portion of the cover 12 stabilizes the first and second lids 10 in their vertical position. The engagement of the well 90 with a portion of the cover 12 prevents the first and second lids 10 from becoming destabilized and/or misaligned.

[0168] The lid 10 can be formed by a variety of manufacturing processes, such as injection molding or a thermoforming operation, preferably vacuum forming and/or pressure forming. The cover 12 is preferably formed from plastic, however, other lightweight materials can be used to form the cover 12. After the manufacturing process has been completed, the drink opening 28 and the slot 30 may be formed in the cover 12 with a punch and die.

[0169] Preferably, the disk 50 is formed from the same material used to form the cover 12. However, the disk 50 can be formed from other lightweight materials. After the manufacturing process has been completed, the aperture 78 may be formed in the disk 50 with a punch and die.

[0170] The lid 10 can include a color-based system for indicating the status of the lid 10. Under the color-based system, a portion of the lid 10 would display a first color, e.g., red, when the lid 10 is closed in the first position P1. Similarly, a portion of the lid 10 would display a second color, e.g., green, when the lid 10 is open in the second position P2. The first and second colors would be displayed in a visible portion of the lid 10 such that a user of the lid 10 could readily ascertain the status of the lid 10. Referring to FIGS. 1 and 4, the first color is positioned on the disk 50 to the right of the post 54 and the second color is positioned on the disk 50 to the left of the post 54. Accordingly, when the lid 10 is in the closed position P1 shown in FIG. 1, the first color is visible through the slot 30. Conversely, when the lid 10 is in the open position P2, the second color is visible through the slot 30. In this manner, a user can verify the status of the lid 10 by simply looking at the color indicator displayed through the slot 30. As a result, the utility and marketability of the lid 10 is increased.

[0171] In an alternate color-based system configuration, the first color is positioned on the projection 52 wherein it is visible when the lid 10 is in the closed position P1. The second color is positioned on the edge 80 about the aperture 78 wherein it is visible when the lid 10 is in the open position P2. In this manner, a user can verify the status of the lid 10 by simply looking at the color indicator displayed in the opening 28.

[0172] FIGS. 5-8 disclose another preferred embodiment of the lid of the present invention. As shown in FIG. 5, the reclosable lid 210 generally includes a first piece or cover 212, and a movable second piece or overlay 250. FIG. 5 shows the lid 210 in the open position wherein the flowable substance can flow or pass through the lid 210 via opening 228.

[0173] Referring to FIGS. 5 and 6, the cover 212 is adapted to span the opening in the upper portion of the container (not

shown) that is generally defined by an upper rim or edge of the container. The cover 212 has an annular top wall 214 and a side wall 216 depending from an outer or peripheral edge 218 of the top wall 214. Although the top wall 214 is shown as having a generally flat upper surface 214a, the upper surface 214a can be curved or angled. The side wall 216 has a side wall surface 216a and a lower edge 220. The side wall surface 216a can be curved, angled, or generally flat. The overall shape of the cover 212 is generally frustoconical, however, the cover 212 can have a number of other configurations.

[0174] A mounting portion 222 depends from the lower edge 220 of the side wall 218. The mounting portion 222 includes a generally annular flange 224 and a generally annular skirt 226. The mounting portion 222 is adapted for connecting the lid 210 to the container in a manner that seals the lid 210 on the container. Thus, the mounting portion 222 prevents leakage of the container contents between the lid 210 and the container when the lid 210 is positioned on the container. In a preferred embodiment, the mounting portion 222 is integral with the side wall 16.

[0175] An aperture or drink opening 228 is located preferably in the top wall 216. Alternatively, the drink opening 228 is located in the side wall 216. The opening 228 is adapted to permit the passage or flow of the flowable contents held by the container through the cover 212. The opening 228 has an edge 229 that defines the shape of the opening 228. Although shown in FIG. 6 as having an obround shape, the opening 228 can have a variety of shapes, including but not limited to circular, square, or rectangular.

[0176] The opening 228 can be formed with a range of dimensions. At a minimum, the opening 228 should have dimensions sufficient to permit the passage of the flowable substance held by the container. The opening 228 can be located at various positions along the top wall 214 depending upon design parameters.

[0177] As shown in FIG. 6, a center portion 236 is positioned radially inward from an inner edge 238 of the top wall 214. Preferably, the center portion 236 is recessed such that the center portion 236 has a curvilinear configuration when viewed in cross-section. Described in a different manner, the center portion 236 has a concave shape when the portion 236 is viewed from a point above the lid 210. The degree of recess or curvature of the center portion 236 can vary with the design parameters of the lid 210.

[0178] Referring to FIGS. 5 and 6, the side wall 216 has a recessed portion 240 that is adapted to receive a lip of a person drinking from the container. An edge 242 of recessed portion 240 defines the configuration of the portion 240. The recessed portion 240 and the recessed surface 240a are positioned radially inward from the side wall surface 216a. Although the recessed portion 240 is shown positioned on both the top wall 214 and the side wall 216, the recessed portion 240 can be limited to either the top wall 214 or the side wall 216. The shape and configuration of the recessed portion 240 can be varied to conform to numerous design parameters. Similarly, the degree of recess of the portion 240 can vary. Preferably, the recessed portion 240 is positioned about the drink opening 228. The top wall 214 and the side wall 216 cooperate to form a rounded edge 240b at the recessed portion 240.

[0179] As shown in FIGS. 5 and 7, the overlay 250 is a discontinuous structure adapted to be positioned about the cover 212. The overlay has a top wall 252 and a side wall 254 depending from an outer or peripheral edge 256 of the top wall 252. Although the top wall 252 is shown as having a

generally flat upper surface 252a, the upper surface 252a can be curved or angled. The side wall 254 has a side wall surface 254a and a lower edge 258. The side wall surface 254a can be curved, angled or generally flat.

[0180] A mounting portion 260 depends from the lower edge 258 of the side wall 254. The mounting portion 260 includes a generally annular flange 262 and a generally annular skirt 264. The mounting portion 260 is adapted for rotatably connecting the overlay 250 to the mounting portion 222 of the cover 212 such that the overlay 250 and the cover 212 are in rotatable engagement. The mounting portions 222, 260 are cooperatively dimensioned such that the overlay 250 can be positioned about the cover 212 wherein the overlay 250 can be rotatably moved with respect to the cover 212. The mounting portions 222, 260 have a generally annular configuration. Alternatively, the mounting portions 222, 260 could have a configuration with angular or linear segments.

[0181] Preferably the mounting portions 222, 260 have a continuous configuration, as shown in FIGS. 5-8. Alternatively, the mounting portions 222, 260 have a discontinuous configuration, meaning that the portions 222, 260 have material removed that results in a notched configuration.

[0182] As shown in FIG. 7, the overlay 250 has a projection 264 that is located preferably in the top wall 252. Alternatively, when the drink opening 228 is positioned in the side wall 216 of the cover 212, the projection 264 is cooperatively positioned in the side wall 254 of the overlay 250. The projection 264 depends from a lower or inner surface (not shown) of the top wall 252. The projection 264 has a peripheral edge 266 that defines the shape of the projection 264. Preferably, the projection 264 is cooperatively dimensioned with the drink opening 228 such that at least a portion of the projection 264 is adapted to be received by or positioned in the opening 228. When the projection 264 is completely received in the opening 228, the opening 228 is sealed and the lid 210 is in the closed position shown in FIG. 8. In the closed position, a bottom wall 268 of the projection 264 extends past the top wall surface 214a.

[0183] As further shown in FIG. 7, a center portion 270 is positioned radially inward from an inner edge 272 of the top wall 252. Preferably, the center portion 270 is recessed such that the center portion 270 has a curvilinear configuration when viewed in cross-section. Described in a different manner, the center portion 270 has a concave shape when the portion 270 is viewed from a point above the lid 210. The degree of recess or curvature of the center portion 270 can vary with the design parameters of the lid 210. Alternatively, the center portion 270 is in planar alignment with the top wall 252. In this configuration, the center portion 270 is not recessed.

[0184] The overlay 250 has at least one gripping element 274 positioned on a portion of the side wall 254. The gripping element 274 is adapted to facilitate rotational movement of the overlay 250. Accordingly, a user engages the element 274 to aid in the rotation of the overlay 250. Although shown as having a generally elongated configuration, the element 274 can have a wide range of configurations and dimensions. In addition, the gripping element 274 can be positioned on the side wall 254, the top wall 252 or on a portion of both the side wall 254 and the top wall 252. Alternatively, the gripping element 274 is positioned on a portion of the mounting portion 260. The gripping element 274 can be integral to the overlay 250 or it can be a separate element fastened to a

portion of the overlay 250. For example, the gripping portion can be a plastic or rubber element fastened to the overlay 250.

[0185] The overlay 250 can have alternate structures for facilitating movement of the overlay 250. For example, the overlay 250 could have a post or a ring extending from a portion of the overlay 250, each adapted for a user to engage and rotate the overlay 250.

[0186] As shown in FIGS. 5, 7 and 8, and as explained above, the overlay 250 has a discontinuous structure, meaning that neither the top wall 252 nor the side wall 254 are continuous along the circumference of the cover 250. As a result, the overlay has a first side wall portion 254b and a second side wall portion 254c. When the projection 264 is located in a portion of the top wall 252, the projection 264 is positioned proximate either of the side wall portion 254b or the second side wall portion 254c. Preferably, the gripping element 274 is positioned on the other of the wall portion 254b or the second side wall portion 254c. Alternatively, the gripping element 274 is positioned on the side wall portion 254b, 254c proximate the projection 264.

[0187] Due to its discontinuous configuration, the overlay 250 has an aperture 276. In one preferred embodiment, the overlay 250 has two aperture 276 wherein the portion of the overlay 250 above the mounting portion 262 has a generally hour-glass shape. The configuration and dimensions of the aperture 276 can vary greatly with the design parameters of the lid 210. Referring to FIG. 7, the overlay 250 has two separate apertures 276a, 276b. Each of the apertures 276a, b span a portion of the side wall 254, the top wall 252 and the center portion 270. Alternatively, the apertures 276a, 276b span only a portion of the side wall 254 and the top wall 252.

[0188] As shown in FIG. 5, the aperture 276 is adapted to permit the passage or flow of the flowable contents held by the container through the opening 228 when the aperture is generally positioned about the opening 228. Described in another manner, when the aperture 276 is aligned with the opening 228, the flowable contents can pass through the opening 228. Therefore, the aperture 276 should have a minimum configuration sufficient to permit the passage of the flowable contents through the aperture 228.

[0189] The cover 212 and the overlay 250 each have a generally thin-wall construction. However, the wall thickness of the cover 212 and the overlay 250 can vary depending upon the design parameters, including the structural integrity of the lid 210.

[0190] Referring to FIGS. 5 and 8, the overlay 250 and the cover 212 are cooperatively dimensioned such that the overlay 250 can be positioned on the cover 212 to define an "assembled position." In the assembled position, the overlay 250 is rotatably supported by the engagement of its mounting portion 260 and the mounting portion 222 of the cover 212. Specifically, a lower surface of the mounting portion 260 engages an upper surface of the mounting portion 222. Accordingly, the mounting portion 260 and the mounting portion 222 are cooperatively dimensioned such that the overlay 250 can be rotated with respect to the cover 212, where the cover 212 is generally fixed to the container.

[0191] In addition, the overlay 250 can be rotatably supported by the engagement of its center portion 270 and the center portion 236 of the cover 212. Specifically, a lower surface of the center portion 270 engages an upper surface of the center portion 236. Accordingly, the center portion 270 is cooperatively dimensioned with the center portion 236 of the cover 212. Alternatively, the lid 210 can be configured to have

a clearance between the center portions 236, 270 such that the center portions 236, 270 are not in engagement. In this configuration, the overlay 250 rotatably engages the cover 212 by the engagement of the mounting portions 222, 260.

[0192] Alternatively, the overlay 250 can be rotatably supported by the engagement of its top wall 252 with the top wall 214 of the cover 212. Accordingly, the top wall 252 is cooperatively dimensioned with the top wall 214 of the cover 212. In another alternative, the overlay 250 can be rotatably supported by the engagement of its side wall 254 with the side wall 216 of the cover 212. Accordingly, the side wall 254 is cooperatively dimensioned with the side wall 216 of the cover 212.

[0193] In the assembled position, the overlay 250 is movable between a first position P1 and a second position P2. In the first position P1, shown in FIG. 8, the projection 264 is received by the drink opening 228 such that the opening 228 is sealed wherein the lid 210 is closed. When the opening 228 is sealed, the edge 229 of the opening 228 is in frictional engagement with the projection 264. A bottom portion (not shown) of the projection 264 can extend past the edge 229 of the drink opening 228. This seal prevents the flow of the flowable substance in the container through the opening 228, enabling the container and lid 210 to be moved without risking spillage. Also, in the first position P1, the aperture 276 is misaligned or offset from the opening 228. Alternatively, the projection 264 and the opening 228 are in a snap fit engagement wherein each have sufficient structure to enable the snap fit engagement. Other cooperating sealing structures can also be utilized.

[0194] In the second position P2, shown in FIG. 5, a user rotates the overlay 250 wherein the aperture 276 is aligned with the drink opening 228 to form a passageway between the overlay 250 and the cover 212. In the second position P2, the lid 210 is open. The passageway permits the passage or flow of the flowable substance held by the container through the lid 210. When the lid 210 is in the second position P2, at least a portion of the aperture 276 is aligned with at least a portion of the edge 229 of the drink opening 228. Also, in the second position P2, at least a portion of the recessed portion 240 of the cover 212 is aligned with the aperture 276. In addition, in the second position P2, the projection 264 is misaligned or offset from the opening 228. When the aperture 276 is partially aligned with the drink opening 228, the passageway remains but its dimensions are reduced.

[0195] When the overlay 250 is moved between the first position P1 and the second position P2, the mounting portion 260 of the overlay 250 remains in rotatable engagement with at the mounting portion 222 of the cover 212. Accordingly, the mounting portions 222, 260 provide support to the overlay 250 such that the overlay 250 remains in the assembled position during movement between the first and second positions, P1, P2.

[0196] When the overlay 250 is moved between the first position P1 and the second position P2, the center portion 270 of the overlay 250 remains in rotatable engagement with the center portion 236 of the cover 212. Accordingly, the center portions 236, 270 provide an additional amount of support to the overlay 250 such that the overlay 250 remains in the assembled position during movement between the first and second positions, P1, P2.

[0197] A user can move the overlay 250 between the first position P1 and the second position P2 by grasping and manipulating a portion of the overlay 250, for example, the

side wall 254, the top wall 252 or the mounting portion 260. Alternatively, when so configured, the user can move the overlay 250 between the first and second positions P1, P2 by engaging the gripping element 274.

[0198] The overlay 250 can be rotated or moved a varying amount depending upon the numerous design parameters of the lid 210, including but not limited to the configuration and dimensions of the side wall 254, the mounting portion 260, the projection 264 and the aperture 276. Thus, the overlay 250 can assume a number of positions with respect to the cover 212. The lid 210 is adapted to permit a user to move the overlay 250 between the first and second positions P1, P2 with only one hand. This means that a user can hold the container and manipulate the overlay 250 with the same hand. This increases the flexibility and the commercial value of the lid 210. As shown in FIGS. 5, 7 and 8, the overlay 250 has two separate apertures 276 which permit the overlay 250 to be rotated in either a clockwise or counter-clockwise direction to move the overlay 250 between the first position P1 and the second position P2. This feature further increases the flexibility and the commercial value of the lid 210.

[0199] The lid 210 is adapted to be used without the overlay 250. This means that the cover 212 is connected to a container but the overlay 250 is omitted. In this configuration, there is no structure to seal the opening 228 in the cover 212 and as a result, the flowable substance held by the container can pass through the lid 210. In this configuration, the recessed portion 240 remains positioned on both the top wall 214 and the side wall 216. However, the drink opening 228 can be positioned in either the top wall 214 or the side wall 216.

[0200] Although shown as having a generally circular shape, the lid 210, including the mounting portions 222, 260, can have numerous configurations. For example, the lid 210 could have a rectangular, square, or oval shape. To ensure a leak-proof seal with the container, the shape of the mounting portion 222, 260 should match the shape of the upper edge of the container so a cooperative sealing engagement can be achieved.

[0201] Alternatively, the mounting portions 222, 260 could have a shape similar to the upper edge of the container, yet dissimilar from the shape of the side walls 216, 254 and the top walls 214, 252. For example, the mounting portions 222, 260 could have an annular shape consistent with the container shape and the side walls 216, 254 and/or the top walls 214, 252 could have a non-annular shape.

[0202] Unlike prior art designs, the dimensions and the configuration of the opening 228 are not affected by the engagement and disengagement of the projection 264 as the overlay 250 is moved between the first and second positions P1, P2. This attribute allows a user to repeatedly move the overlay 250 between the first position P1 and the second position P2. Accordingly, the structural integrity and the durability of the lid 210 are increased.

[0203] The lid 210 can be formed by a variety of manufacturing processes, such as injection molding or a thermoforming operation, preferably vacuum forming and/or pressure forming. The cover 212 is preferably formed from plastic, however, other lightweight materials can be used to form the cover 212. After the manufacturing process has been completed, the drink opening 228 may be formed in the cover 212 with a punch and die. The aperture 276 could also be formed with a punch and die.



[0204] Preferably, the overlay 250 is formed from the same material used to form the cover 212. However, the overlay 250 can be formed from other lightweight materials.

[0205] The cover 212 can have at least one cover drain hole (not shown), preferably positioned in the center portion 236 near a lowermost portion of the center portion 236. When excess flowable contents, e.g., liquid, accumulate on the cover 212, the drain hole ensures the drainage of such contents into the container.

[0206] The overlay 250 can have an overlay drain hole (not shown), that is cooperatively dimensioned with the cover drain hole described above. The overlay drain hole is cooperatively positioned with the cover drain hole such that when the overlay 250 is rotated to the first position P1, the cover drain hole and the overlay drain hole align to form a passageway that ensures the drainage of accumulated container contents. Alternatively, the overlay drain hole is cooperatively positioned with the cover drain hole such that when the overlay 250 is rotated to the second position P2, the cover drain hole and the overlay drain hole align to form the passageway.

[0207] The cover 212 can have at least one cover vent hole (not shown), preferably in the center portion 236 or the side wall 216. Alternatively, the cover vent hole is positioned in a portion of the top wall 214 or a portion of the side wall 216. The cover vent hole is adapted to ensure the continuous flow of the container contents through the opening 228 while venting the container. Preferably, the cover vent hole is positioned such that the venting of the container occurs while the lid 210 is in the second position P2.

[0208] The overlay 250 can have an overlay vent hole (not shown), that is cooperatively dimensioned with the cover vent hole described above. The overlay vent hole is cooperatively positioned with the cover vent hole such that when the overlay 250 is rotated to the second position P2, the cover vent hole and the overlay vent hole align to form a passageway that ensures the venting of the container.

[0209] The drain holes and the vent holes described above can be formed with a punch and die after the lid 210 manufacturing process has been completed. Alternatively, a pointed tool may be used to form the drain holes and the vent holes.

[0210] In another preferred embodiment (not shown), the lid has at least one pin on either the overlay or the cover. In addition, the lid has at least one socket on the other of the overlay or the cover. The pin and the socket are cooperatively dimensioned such that when the pin is received by the socket, the overlay is in rotational engagement with the cover. Because the overlay and the cover are in rotational engagement, the lid can be rotated between the first and second positions P1, P2. The pin and socket are adapted to support the overlay when the lid is rotated between the first and second positions P1, P2.

[0211] The cover has a center portion that can be recessed. The overlay is a discontinuous structure that is adapted to be positioned about the cover. The overlay has at least one aperture that is alignable with an opening in the cover. Preferably, the pin depends from a lower surface of the overlay, and the socket depends from an upper surface of the cover. In this configuration, the socket is positioned in the center portion of the cover.

[0212] The overlay can include an annular mounting portion that engages a mounting portion of the cover. The overlay mounting portion supports the overlay during movement

between the first and second positions. Alternatively, the overlay includes a mounting portion but it is segmented, meaning that it is not annular.

[0213] In another alternative, the annular mounting portion is omitted from the overlay. In this configuration, the pin and socket primarily support the overlay when the lid is rotated between the first and second positions P1, P2.

[0214] FIGS. 9 and 10 disclose an alternate embodiment of a lid of the present invention, generally designated with the reference numeral 310. The lid 310 generally includes a cover 312 and the movable or rotatable element or disk 50, and the similar elements thereof retain their reference numerals. The lid 310 is shown having a tab 323 extending from a portion of the cover 312. The tab 323 is adapted to permit a user to easily position and/or remove the lid 310 from a container 325. The tab 323 extends radially outward from the mounting portion 322. Described in a different manner, the tab 323 extends radially from the peripheral edge 360 of the skirt 326. However, the tab 323 can extend from a different portion of the cover 312, including the side wall 16 or the flange 324. Although a single tab 323 is shown, the lid 310 can have a plurality of tabs 323 wherein the tabs 323 are spaced about the mounting portion 322. The tab 323 has a curved peripheral edge 327 that causes the tab 323 to have a curvilinear configuration. Alternatively, the tab 323 has an angular or linear configuration. As shown in FIG. 11, the thickness of the tab 323 generally corresponds to the thickness of the mounting portion 322. However, the thickness of the tab 323 can be either increased or decreased as necessary.

[0215] An alternate tab 423 extending from the mounting portion 322 is shown in FIG. 12. The tab 423 has a curvilinear configuration with a first segment 429, a second segment 431, and a third segment 433. The first segment 429 extends radially outward from an edge 360 of the skirt 326. The second segment 431 is angled or sloped upward from the first segment 429 to the third segment 433 whereby the tab 423 has a "stepped" configuration. The third segment 433 has a rounded edge 427 which causes the tab 423 to have a curvilinear configuration. Alternatively, the third segment 433 has a squared end or terminus. When viewed from above, a channel 435 is defined by the skirt 326, the first segment 429, and the second segment 431. The first segment 429 defines a first plane, the second segment 431 defines a second plane, and the third segment 433 defines a third plane. Due to the angled second segment 431, the first plane and the third plane are misaligned. Described in a different manner, the first plane is not in planar alignment with the third plane. Further, neither the first plane nor the third plane are in planar alignment with a plane defined by the flange 324. In another alternative (not shown), the tab has a second segment that is angled or sloped downward from the first segment towards the third segment causing the tab to have a stepped configuration in a downward direction. With this alternate design, the third segment is positioned lower than the skirt of the mounting portion.

[0216] As described above, the lid 310, or portions thereof can be formed by a variety of manufacturing processes, such as injection molding or a thermoforming operation, preferably vacuum forming and/or pressure forming. However, the primary components of the lid, the cover 312 and the rotatable element 50, can be formed from distinct processes. For example, the cover 312 can be thermoformed while the rotatable element 50 can be injection molded. Furthermore, the cover 312 and/or the element 50 can be co-injection molded, meaning that multiple polymers can be used to form the

element 50. For example, the rotatable element 50 can be formed from a thermoplastic polymer and a thermoset polymer. In addition, an additive such as a filler, plasticiser, stabilizer, or colorant can be utilized to form the cover 312 and/or element 350.

[0217] Preferably, the tab 323 is integrally formed with the cover 312. Preferably, the thickness of the tab 323 corresponds with the cover 312, however, it can differ based upon design parameters of the lid 310. A conventional cutting tool is used to trim excess material from the lid 310 to form the tab 323. The precise configuration and/or thickness of the tab 323 can be revised by the changing the operating parameters of the cutting tool.

[0218] As also mentioned above, the tab 323 is adapted for a user to easily position and/or remove the lid 310 from the container 325. When the lids 310 are stacked in a vertical arrangement at a retail distribution point, an employee can grasp the tab 323 to quickly separate the uppermost lid 310 from others within the stack. The tab 323 furthers the assembly of the cover 312 and the rotatable element 50. During the step of assembling the cover 312 and the rotatable element 50, the tab 323 helps to fix the position of the cover 312 such that the rotatable element 50 can be properly positioned within the interior region of the cover 312. The tab 323 enhances the alignment between the cover 312 and the element 50 to effectuate the assembly of the lid 310. Referring to FIG. 10, the tab 323 of the lid 310 is shown positioned between a pair of guides or pegs G, which typically extend from a piece of equipment or tooling. Alternatively, the tab 323 is positioned against a single guide G. The interaction between the guides G and the tab 323 secures the lid 310 in a pre-assembly position wherein the cover 312 is separated from the rotatable element 50. In the pre-assembly position, the precise location of the slot 30 is fixed to facilitate reception of the actuator 54. Described in a different manner, the angular orientation of the cover 312, including the slot 30 is fixed. While the tab 323 is positioned between the guides G, the rotatable element 50 is moved towards the interior region of the cover 312. To reach an assembled position, the rotatable element 50 is positioned within the interior region of the cover 312 whereby the actuator 54 is received by the slot 30. In addition, the rotatable element 50 is positioned such that it rotatably engages the support members 102. Thus, the tab 323 helps to ensure the proper assembly and formation of the lid 310. In addition to providing positioning benefits during assembly of the lid 310, the tab 323 provides positioning benefits during the use of the lid 310. Specifically, the tab 323 provides tactile feedback for a user to determine the position of the drink opening 28 with respect to the position of the tab 323. This aspect is beneficial in low light conditions.

[0219] As shown in FIG. 1, the cover 12 has a drink opening 28 that is adapted to receive the projection 52 of the rotatable element 50 in the first position P1. The drink opening 28 is shown as being positioned in the top wall 14 of the cover 12. However, a spout can extend upward in a generally vertical manner from the top wall 14 and include a drink opening. In this manner, the drink opening is positioned above the top wall 14 due to the spout. In the first position P1, the flowable contents of the container flow through the aperture 78 of the element 50 and the spout. The spout can extend upwardly from the top wall 14 or a combination of the top wall 14 and the central region 36. Preferably, the spout is integrally formed with the cover 12. The dimensions of the spout, including the height and the width, vary with the design

parameters of the lid 10. Preferably, the spout is cooperatively dimensioned with the projection 52 such that a base region of the spout receives the projection 52 to generally seal the opening 28 of the lid 10 in the second position P2.

[0220] Referring to FIG. 3 and as mentioned above, the cover 12 has a plurality of support members 34 and support ledges 102, where the support ledges 102 extend into the interior region of the cover 12 from the side wall 16. As shown in FIG. 13, a cover 412 has a support ledge 102B that is positioned within the recessed portion 40 of the side wall 16 and near the drink opening 28. Alternatively, the recessed portion 40 is omitted and the support ledge 102B is positioned near the drink opening 28. In yet another alternative, a pair of support ledges 102B can extend inward from the side wall 16 and be positioned about the drink opening 28. As fully explained above, the rotatable element 50 is rotatably supported by the ledges 102 such that the element 50 is moveable between the first and second positions P1, P2. As shown in FIG. 13, the support ledge 102B has a reduced length compared to the other support ledges 102. However, the dimensions including the length of the support ledges 102, 102B can vary with the design parameters of the cover 12. The positioning of the support ledge 102B near the drink opening 28 enhances the operation of the rotatable element 50. In the first or closed position P1, the support ledge 102B provides further support to the element 50 such that the projection 52 is properly received by the drink opening 28. In the second or open position P2, the support ledge 102B provides further support to the element 50 such that the aperture 78 remains properly aligned with the drink opening 28. Furthermore, in either position P1, P2, the interaction between the support ledge 102B and the rotatable element 50 minimizes the chance for seepage past the element 50 in the region about the drink opening 28. Although the cover 412 is shown as not having the tab 323 of FIGS. 9-11, it is understood that the cover 412 can have a tab and that such structure will not interfere with the operation of the lid 412.

[0221] As shown in FIG. 13, the support ledges 102, 102B extend radially inward from the inner surface 100 of the side wall 16 of the cover 412. Alternatively, the cover 412 has a support channel in the side wall 16 wherein the channel is adapted to rotatably support the element 50. In this manner, the support channel is recessed into the side wall 16 such that it does not extend beyond the inner surface 100. The support channel can be positioned along the entire circumference of the side wall 16, or an extent of the circumference. The support channel can be continuous or interrupted, meaning spaced along the circumference of the side wall 16. Preferably, the element 50 has a rib or rail that is received by the support channel to rotatably support the element 50. To ensure proper rotation of the rotatable element 50, the rib and the support channel are cooperatively dimensioned. The rib can extend from a number of locations of the element 50, including the top wall 56, the side wall 59, or the lower edge 51. Like the support channel, the rib can be continuous or interrupted. For larger containers, the size of the cover 12 can be increased such that cover 12 has a plurality of support channels and the rotatable element 50 has a corresponding number of cooperating ribs. Preferably, the support channel in the side wall 16 is dimensioned to receive only the rib of the element 50. Alternatively, the height of the support channel is increased such that a greater extent of the element 50 is rotatably received. This means at least the outer edge 51 and the side wall 59 of the element 50 are received by the larger

support channel. In another alternative, the support channel and rib configuration is reversed such that the rotatable element 50 has a recessed channel that receives a rib of the cover 12.

[0222] As explained above, the rotatable element 50 is moveably supported by support ledges 102 located in the side wall 16. Alternatively, the rotatable element 50 is rotatably supported by other portions of the cover 12 such as the top wall 14 and/or the central portion 36 of the cover 12. Thus, the top wall 14 could have at least one structure adapted to rotatably support the element 50. For example, a support ledge 102 can depend from the top wall 14 and rotatably support the element 50. In this configuration, the support ledge 102 depends from the top wall 14 at a position radially inward of the peripheral edge of the top wall 14. This support ledge 102 has a horizontal component that engages and rotatably supports the element 50, which can be a ring-shaped structure. As another example, a support ledge 102 can depend from the central portion 36 and rotatably support the element 50. As yet another example, a support ledge 102 can extend from the point where the top wall 14 and the side wall 16 converge. In is further understood that the element 50 could be rotatably supported on a top surface of the cover 12.

[0223] Referring to FIG. 4, the rotatable element or disk 50 has an aperture 78 that is aligned with the drink opening 28 in the second or open position P2. Alternatively and as shown in FIG. 14, the aperture 78 is omitted and the element 450 has at least one structure configured to define a passageway for the flow of the container contents. In a preferred embodiment, the element 450 has a notch 478 that defines a channel or passageway 479. The dimensions of the passageway 479 are determined by the width and length of the notch 478. The notch 478 extends radially inward from the outer edge 51 of the element 450. The notch 478 terminates prior to the top wall 56 of the element 450. However, the notch 478 can extend into the top wall 56 and/or into the inner shoulder 60 of the element 450. The notch 478 is positioned adjacent the recessed portion 84 of the element 450. In the first position P1, the notch 478 is misaligned with the drink opening 28 causing misalignment between the passageway 479 and the opening 28. In the second position P2, the notch 478 is generally aligned with the drink opening 28 causing the passageway 479 to be aligned with the opening 28. As a result, the passageway 479 permits the passage of the flowable substance held by the container through the lid 10. In yet another alternative, the element 450 has an upwardly directed or raised segment that defines a channel or passageway. To prevent binding of the rotatable element during its movement between the first and second positions P1, P2, the height of the raised segment corresponds to the height of the projection 52.

[0224] As discussed above and as shown in FIG. 14, the center or central portion 462 of the rotatable element 450 has an opening 463. As a result of the opening 463, the element 450 has a ring-shaped configuration. The opening 463 is adapted to permit the drainage of the liquid contents of the container pass between the element 450 and the cover 12. Although the diameter of the opening 463 is shown as roughly corresponding to the diameter of the wells 90, the size of the opening 463 can vary with the design parameters of the rotatable element 450. As a result, the dimensions of the ring-shaped element 450 will vary. For example, the diameter of the opening 463 is increased and the width of the center portion 462 corresponds to the width of the top wall 56 of the rotatable element 450.

[0225] In another embodiment, the rotatable element 50 has a band extending radially outward from the peripheral or outer edge 51 proximate the projection 52. The band is adapted to increase the sealing of the drink opening 28 by the projection when the lid 10 is in the closed or first position P1. Preferably, the band has a rectangular configuration and extends outward from the recessed portion 84 of the element 50. When the lid 10 is in the closed position P1, the band is positioned beneath the drink opening 28 and against the inner surface 100 of the cover 12. In this manner, the band helps to further seal the drink opening 28 in the closed position P1. The rotatable element 50 could also have a projection 52 with pliable characteristics to assist in sealing the drink opening 28. This type of projection 52 can be formed, for example, using a two-shot injection molding process.

[0226] In another embodiment, the rotatable element 50 has a recessed portion 84 with a vertical side wall 59. When the element 50 is viewed from the side, the vertical side wall 59 forms a shoulder or ledge (not shown) near the peripheral edge 51 of the element 50. The shoulder has a vertical wall component that originates at the peripheral edge and terminates near the edge 80 of the aperture 78. The shoulder extends an extent of the recessed portion 84. Preferably, the shoulder extends along the projection 52 and the aperture 78. The vertical side wall 59 is adapted to aid the interaction between the recessed portion 84 and the recess 40 of the cover 12.

[0227] FIGS. 15 and 16 disclose an alternate embodiment of a lid of the present invention generally designated with the reference numeral 510. The lid 510 generally has a cover 512 and the rotatable element 550, and the similar elements thereof retain their reference numerals. The lid 510 has a slot 530 with increased dimensions. Specifically, the arc length of the slot 530 is increased. In the first or closed position P1 shown in FIG. 15, the actuator 54 is positioned between a first slot portion 530a and a second slot portion 530b. Thus, two distinct slot portions 530a, b flank the actuator 54 in the first position P1. In the first position P1, the actuator 54 is positioned at the general midpoint of the slot 530. The rotatable element 550 has a first aperture 78 and a second aperture 578, wherein the apertures 78, 578 are positioned about the projection 52. Preferably, the second aperture 578 is positioned in the recessed portion 84 of the element 550. Like the first aperture 78, the second aperture 578 has a peripheral edge 580 that defines the shape of the aperture 578. When the second aperture 578 is aligned with the drink opening 28, a passageway is formed between the disk 50 and the cover 512 permitting the passage or flow of the flowable substance held by the container through the lid 510. To move the lid 510 from the first position P1 to the open or second position P2, a user actuates the actuator 54 in either a clockwise or counter-clockwise direction such that either the first aperture 78 or the second aperture 578 is aligned with the drink opening 28. Therefore, the lid 510 is capable of movement in one of two distinct directions from the first position P1 to the second position P2, which increases the utility of the lid 510. Alternatively, the lid 510 has a pair of projections 52 positioned about the first aperture 78. In this configuration, to move the lid 510 from the second position P2 to the closed or first position P1, a user actuates the actuator 54 in either a clockwise or counter-clockwise direction such that either the first projection 52 or the second projection 52 is received by the drink opening 28.

[0228] Although the rotatable element 50 is shown in FIG. 4 as having a disk configuration, the element 50 can have a variety of configurations. For example, the rotatable element 50 can have a ring-shaped configuration. Also, at least one spoke or rib can be added to the ring-shaped element 50 to increase its structural integrity. The spoke(s) can have a recessed central portion that corresponds with the recessed configuration of the central region 36 of the cover 12. Alternatively, the rotatable element 50 can have a hour-glass shaped configuration where the portions not having either the post 54 or the recessed portion 84 are removed. This configuration reduces the quantity of material used to fabricate the rotatable element 50.

[0229] Again referring to FIG. 4, the rotatable element 50 has an actuator 54 defined by a post that extends generally upward from a top wall 56 of element 50. Alternatively, the post 54 depends downward from the top wall 56 to define a well. The well is cooperatively dimensioned with the slot 30 of the cover 12 such that a user can actuate the lid 10 between the first position P1 and the second position P2. For example, a user can insert a finger into the slot 30 and the well formed by the depending post 54 to actuate the element 50 between the first and second positions P1, P2. Thus, the well is adapted to receive a user's finger to actuate the rotatable element 50. In another alternative, the actuator 54 is defined by a plurality of protrusions such that a user can engage the protrusions to actuate the rotatable element 50 between the first and second positions P1, P2.

[0230] FIGS. 17 and 18 disclose an alternate embodiment of a lid of the present invention generally designated with the reference numeral 610. As shown therein, the support members 34 and the resulting support ledges 102 are omitted from the side wall 616 of the cover 612. Also, the actuator or post 654 of the rotatable element 650 has a flange 671 that is adapted to slidably engage the top wall 14 of the cover 612. As explained above, in an assembled position, the post 654 extends through the slot 30 in the cover 612 wherein the flange 671 slidably engages a portion of the top wall 14 of the cover 12. This means that a lower surface of the flange 671 slidably engages the upper surface 14a of the top wall 14. The interaction between the flange 671 and the top wall 14 provides moveable support for the element 650 such that the element 650 is rotatable between the first position P1 and the second position P2. Thus, the flange 671 provides means for supporting the element 650 within the internal cavity 38 of the cover 612 whereby the element 650 is rotatable between the first and second positions P1, P2.

[0231] As shown in FIGS. 17 and 18, the flange 671 is positioned about the end walls 674 and the side walls 674, but below the top wall 676 of the post 654. Also, the flange 671 extends from the periphery of the post 654 such that the post 654 has a "T-shaped" configuration. Preferably, the flange 671 is integrally formed with the post 654 and is flexible. As a result, when the post 654 is inserted into the slot 30 during the assembly process, the flange 671 flexes as it passes through the slot 30 and then returns to its original configuration (meaning un-flexed) when it clears the slot 30. The flange 671 defines a plane that is in planar alignment with a plane defined by the top wall 14 of the cover 612. Alternatively, the flange 671 is angled, peaked, or sloped. The flange 671 has a length and a width, wherein each is greater than a length and width of the post 654. Preferably, the width of the flange 671 corresponds with the width of the top wall 14 of the cover 612. One of ordinary skill recognizes that the dimensions of the

flange 671 can not be so great as to preclude the passage of the flange 671 through the slot 30.

[0232] The lid 610 is shown as having the flange 671 and no support members 34. However, the lid 610 can have a combination of these structures. For example, the lid 610 could include the flange 671 and at least one support member 34 and the resulting support ledge 100. In this configuration, the element 650 is rotatably supported by the interaction between the flange 671 and the top wall 14 and by the interaction between the peripheral edge 51 of the element and the support ledge 100. As another example, the lid 610 could have two or more posts 654 and a corresponding number of slots 30, wherein each post 654 has a flange 671 that slidably engages the top wall 14 of the cover 612 near each respective slot 30. In this manner, the element 650 is rotatably supported by the interaction between multiple flanges 671 and the top wall 14.

[0233] FIGS. 19-22 disclose an alternate embodiment of a lid of the present invention generally designated with the reference numeral 710. The lid 710 generally has a cover 712 and the rotatable element 750, and the similar elements thereof retain their reference numerals. The cover 712 has a side wall 716 with a vertical channel or rib 717. The vertical channel 717 is internal to the cover 712, however, the channel 717 protrudes from the outer surface 716a of the side wall 716. This means that the side wall 716 is raised at the channel 717. The channel 717 extends between the lower edge 20 of the side wall 716 and the peripheral edge 18 of the top wall 714. This means that the channel 717 is positioned between the mounting portion 22 and the top wall 714. The channel 717 is adapted to provide a first passageway for the flow of the flowable contents through the lid 710. In this manner, the channel 717 provides a generally vertical passageway for the content to flow to the opening 28 of the lid 710.

[0234] Referring to FIG. 22, the rotatable element 750 has a first projection 752 and a second projection 753. The projections 752, 753 are spaced a distance apart but remain within the recessed portion 784 of the element 750. Since the portion 784 is recessed or depressed with respect to the top wall 756 of the element 750, the element 750 has transition walls 785 between the top wall 756 and the recessed portion 784. Furthermore, the recessed portion 784 defines a plane that is below a plane defined by the top wall 756. Unlike recessed portions discussed above, the recessed portion 784 has increased dimensions such that the recessed portion 784 extends to the peripheral edge 751 of the element 750. Described in a different manner, the recessed portion 784 has an extended portion 784a that is coincident with the peripheral edge 751. As a result, an extent of the outer shoulder 758 and the side wall 759 approximate the extended portion 784 are omitted. Due to the configuration of the recessed portion 784, the aperture 78 is omitted. The recessed portion 784 is adapted to provide a second passageway for the flow of the flowable contents through the lid 710. The rotatable element 750 has an opening 763 and a plurality of wells 790 positioned radially outward of the opening 763. The recessed portion 784 is shown as spanning a pair of wells 790, however, the dimensions of the portion 784 can vary with the design parameters of the lid 710.

[0235] The lid 710 is movable between a closed or first position P1 and an open or second position P2. In the first position P1 shown in FIGS. 19 and 21A, the first projection 752 is received by the drink opening 28 of the cover 712. The second projection 753 is positioned beneath the top wall 714 but preferably beyond the lip recess 40 of the cover 712. Also,

the channel 717 is positioned between the first and second projection 752, 753. Furthermore, the post 54 of the rotatable element 750 extends through the slot 30 of the cover 712. Although the vertical channel 717 creates a fluid passageway, the first projection 752 obstructs fluid flow through the drink opening 28 of the cover 712.

[0236] Consistent with that explained above, the post 54 is actuated to move the lid 710 between the first and second positions P1, P2. In the open or second position P2 shown in FIG. 21B, both the first projection 752 and the second projection 753 are misaligned with the drink opening 28. Described in a different manner, the first and second projections 752, 753 are positioned about the opening 28. Referring to FIG. 21B, the first projection 752 is shown as being positioned beyond the opening 28, while the second projection 753 is not shown due to the section line used to section FIG. 19. In the second position P2, the recessed portion 784 of the element 750 is in fluid communication with the channel 717. Specifically, the extended portion 784a of the recessed portion 784 is in fluid communication with the channel 717. In the second position P2, the second projection 753 is positioned between the drink opening 28 and the channel 717. In the second position P2, the interaction between the cover 712 and the projections 752, 753 exerts a downwardly directed force on the element 750 which deflects the element 750. This deflection of the element 750 creates a clearance C between the inner surface of the cover 712 and the rotatable element 750. Specifically, the interaction between the first projection 752 and/or second projection 753 and an inner surface of the top wall 40c of the recessed portion 40 causes the element 740 to deflect or flex which results in the clearance C near the drink opening 28 of the cover 712. The clearance C is a function of the deflection of the rotatable element 750. Preferably, the region of deflection of the element 750 is the recessed portion 784. The top wall 40c of the recessed portion is positioned below the top wall 714 of the cover 712 which is evidenced by the notch or step between the top wall 40c and the top wall 714. The clearance is further defined by the extended portion 784a of the recessed portion 784 of the rotatable element 750. The clearance C completes the fluid passageway that allows the container contents to flow through the drink opening 28. Accordingly, the fluid passageway is formed by the vertical channel 717 and the clearance C between the rotatable element 750 and top wall 40c about the drink opening 28. The clearance C is maintained while the rotatable element 750 is rotatably supported by the support members 102 of the cover 712. The top walls 714, 40c are dimensioned such that the first projection 752 and/or the second projection 753 can slidably engage the inner surface thereof to permit movement between the first and second positions P1, P2.

[0237] FIGS. 23-28 disclose another embodiment of the reclosable lid of the present invention, generally designated with the reference numeral 810. Like the previous embodiments, the lid 810 is adapted to be attached to a container 825. The container 825 has a central opening defining a volume that can be used to hold or contain a flowable substance, for example a liquid. The container 825 and the lid 810 can be of either the disposable or extended use variety. FIGS. 23 and 24 show the lid 810 in a closed position P1 wherein the lid 810 is sealed such that the flowable substance cannot flow through the lid 810. FIG. 28 shows the lid 810 in an open position P2, wherein a flowable substance may flow from the container

825 and through the lid 810. The lid 810 generally comprises a cover 812 and a moveable or rotatable element 850.

[0238] The cover 812 is adapted to be attached to the container 825 that holds a flowable substance. The cover 812 is adapted to span the opening in the upper portion of the container 825 that is generally defined by an upper rim or edge 827 of the container 825. For illustrative purposes, the container 825 could be a coffee cup having an opening defined by the rim of the cup. The cover 812, as illustrated in FIGS. 23-25, generally has a top wall 814, a side wall 816, and a mounting portion 822 adapted to be attached to the container 825.

[0239] The top wall 814 is generally annular, although other configurations are possible. The side wall 816 depends from a peripheral edge 818 of the top wall 814. Although the top wall 814 is shown as having a generally level upper surface 814a, the upper surface 814a can be curved or angled. The side wall 816 has a side wall surface 816a and a lower edge 820. The side wall surface 816a can be curved or generally flat. The overall shape of the cover 812 is generally frustoconical, however, the cover 812 can have a number of other configurations.

[0240] A mounting portion 822 depends from the lower edge 820 of the side wall 816, and can be considered as part of the side wall 816. The mounting portion 822 includes a generally annular flange 824 and a generally annular skirt 826. The mounting portion 822 is adapted for connecting the lid 810 to the container 825 in a manner that seals the lid on the container 825. Thus, the mounting portion 822 prevents leakage of the container 825 contents between the lid 810 and the container 825 when the lid 810 is positioned on the container 825. In a preferred embodiment, the mounting portion 822 is integral with the side wall 816.

[0241] A drink opening 828 is located preferably in the top wall 814. Alternatively, the opening 828 is located in the side wall 816. The opening 828 is adapted to permit the passage or flow of the flowable contents held by the container 825 through the cover 810. The opening 828 has an edge 829 that defines the shape of the opening 828. Although shown in FIGS. 23-25 as having an obround shape, the opening 828 can have a variety of shapes, including but not limited to circular, square, or rectangular.

[0242] A slot or channel 830 is located preferably in the top wall 814. Alternatively, the slot 830 may be located in the side wall 830. The slot 830 permits access to the actuator 854 used for rotating the moveable element 850 as described in greater detail below. The slot 830 has an edge 832 that defines the shape of the slot 830. Although shown in FIGS. 23-25 as having an obround shape, the slot 830 can have a variety of shapes, including but not limited to circular, square, or rectangular. Because the slot 830 must provide access to the actuator 854, the shape and size of the slot 830 will be related to the form and size of the actuator 854. As previously described, in an alternate embodiment, the moveable element 850 can have two apertures. While most features of the cover 810 need not be changed to adapt to a double-aperture element, the slot 830 may need to be enlarged to accommodate the larger range of motion required to move between additional positions.

[0243] As further shown in FIGS. 23, 25 and 27, the cover 810 has a support member 837, which preferably depends from a central portion 836 of the top wall 814. In a most preferred embodiment, the support member 837 depends from a center of the top wall 814. The support member 837 is

adapted such that the rotatable element **850** may be rotatably mounted on the support member **837**. The support member **837** is generally a cylindrical protrusion in the underside of the top wall **814**, and has an inner side wall **837a** and an outer side wall **837b**. Alternatively, the support member **837** may be embodied in one of many other shapes and forms. For example, the support member **837** may contain or comprise a lip or cusp (not shown) for securing the disk. Furthermore, although in the preferred embodiment, the support member **837** is located substantially in the center of the top wall **814**, it need not be located in the center, nor even in the top wall **814**. Additionally, the support member **837** need not depend from the top wall **814**, and may comprise any form on which the element **850** may be rotatably mounted, for example a depression on the underside of the top wall **814** (which may form a projection from the upper side of the top wall) or an aperture through the top wall **814**. Preferably, the support member **837** is integral with the top wall **814**, but a separable support member would function suitably. In addition, the support member **837** may comprise a separate rivet member. The support member **837** could also comprise a generally arrowhead-shaped member that cooperates with an opening in the moveable element **850**. The support member **837** could also form part of a ball and socket arrangement with the moveable element **850** to rotatably support the element **850**. It is further understood that in a preferred embodiment, the element **850** is rotatably supported on an underside of the cover **812**. It is appreciated, however, that the element **850** could be supported on a top surface of the cover **812** to provide the reclosable lid of the present invention.

[0244] As shown in FIG. 23, the top wall **814** has a center portion **836** which is preferably recessed such that the center portion **836** has a curvilinear configuration when viewed in cross-section. The degree of recess or curvature of the center portion **836** can vary with the design parameters of the lid. Alternatively, the entire top wall **814** is in planar alignment. In this configuration, the center portion **836** is not recessed.

[0245] Referring to FIGS. 23 and 24, the side wall **816** has a recessed portion **840**, which is adapted to receive a lip of a person drinking from the container. An edge **842** of the recessed portion **840** defines the configuration of the portion. The recessed portion **840** is positioned radially inward from the side wall surface **816a**. Although the recessed portion **840** is shown positioned on both the top wall **814** and the side wall **816**, the recessed portion **840** can be limited to either the top wall **814** or the side wall **816**. The shape and configuration of the recessed portion **840** can be varied to conform to numerous design parameters. Similarly, the degree of recess of the portion **840** can vary. For example, as shown in FIG. 1, the recessed portion **840** is deeper at a base portion and shallower at an end proximate the drink opening **828**. Preferably, the recessed portion **840** is positioned about the drink opening **828**. The top wall **814** and the side wall **816** cooperate to form a rounded edge or shoulder **840b** at the recessed portion **840**. It is further understood that the cover **812** of the lid **810** could also have a tab formed thereon as shown in the embodiment of FIG. 9.

[0246] The moveable element, or disk, **850** is illustrated in FIGS. 23 and 26. The element **850** is rotatably mounted on the support member **837** of the cover **812** such that the support member **837** is received in a portion of the element **850**. As discussed above, several structures have been disclosed and other structures are possible wherein the element **850** is rotatably supported with respect to the cover **812**. In addition,

although the moveable element **850** is illustrated as a disk, and is referred to interchangeably as a “disk” throughout this description, this is only illustrative of the preferred embodiment. The moveable element **850** may take any of a multitude of forms other than a disk, and the shape of the movable element **850** is not a limitation of the present invention. For example, the disk can be ring-shaped as described above in other embodiments of the invention.

[0247] As shown in FIG. 26, the element **850** has an aperture **878**, an actuator **854** accessible through the slot **830**, a projection **852**, and an indentation or depression **881**. The element **850** has an outer edge **851** and a top wall **856** with an top wall surface **856a** and a center portion **862**. A side wall **859** depends from the top wall **856**. The top wall **856** has a center portion **862** extending radially inward from the top wall surface **856a**. Preferably, the center portion **862** is recessed such that the center portion **862** has a curvilinear configuration when viewed in cross-section. The degree of recess or curvature of the center portion **862** can vary with the design parameters of the lid **810**. Preferably, the degree of recess of the center portion **862** of the element **850** is similar to the degree of recess of the center portion **836** of the cover **812**. Alternatively, if the entire top wall **814** of the cover **812** is in planar alignment, the top wall surface **814a** and the center portion **862** of the element **850** are also in planar alignment.

[0248] The projection **852** extends from a portion of the top wall **856**. The projection **852** has a peripheral edge **853** that defines the shape of the projection **852**. Preferably, the projection **852** is cooperatively dimensioned with the drink opening **828** such that at least a portion of the projection **852** is adapted to be received by, or positioned in, the opening **828**. The projection **852** has a projection surface **852a** that is preferably sloped or angled to facilitate reception of the projection **852** by the opening **828**. When the projection **852** is completely received in the opening **828**, the opening **828** is sealed and the lid **810** is in the closed position shown in FIG. 23. Although the presence of the projection **852** is preferable, it is not essential to the present invention. Alternatively, the element **850** has a generally planar surface that is aligned with a surface of the cover **812** proximate the opening **828** in a surface-to-surface engagement such that the opening **828** is sealed. Such as shown in the above embodiments, the element **850** can have an opening adapted to drain the flowable contents into the container **825**.

[0249] The actuator **854** is accessible through the slot **830** in the cover **812**, and is manipulated to move the element **850** between an open position **P2** and a closed position **P1**. As illustrated in FIG. 26, the actuator **854** is preferably a post, but may take any other form suitable for manipulation. For example, the actuator **854** could be a small projection or protuberance; a series of smaller projections, bumps, or ridges; or simply a high-friction surface. The post **854** of the preferred embodiment extends from a portion of the top wall **856**. In an alternative embodiment, the post or actuator **854** may be positioned on the side wall **859** of the element **850**, and the slot **830** may be correspondingly positioned on the side wall **816** of the cover **812**. The post **854** can have either a solid or hollow construction depending upon design parameters. At least a portion of the post **854** is received by the slot **830** and extends past the top wall surface **814a**. Although the configuration and dimensions of the post **854** can vary according to design parameters of the lid **810**, the post **854** must retain a configuration that permits it to be accessible

through the slot 830. As shown in FIG. 26, the post 854 has a catenoid shape. The post 854 can have a gripping portion (not shown) that is adapted to facilitate the engagement of a user's fingers with the post 854. The gripping portion can be integral to the post 854 or it can be a separate element fastened to a portion of the post 854. For example, the gripping portion can be a plastic or rubber element fastened to the walls of the post 854.

[0250] As shown in FIG. 26, the disk 850 has at least one aperture 878. The aperture 878 has a peripheral edge 880 that defines the shape of the aperture 878. When the aperture 878 is aligned with the drink opening 828, a passageway is formed between the element 850 and the cover 812 permitting the passage or flow of the flowable substance held by the container 825 through the lid 810. Although the aperture 878 can have a variety of configurations and dimensions, the aperture 878 is preferably cooperatively dimensioned with the drink opening 828. In a preferred embodiment, the aperture 878 is positioned on the disk top wall 856 and spaced a distance from the projection 852. In another preferred embodiment, similar to the embodiment described in FIGS. 15-16, the element 850 could include two separate apertures, each spaced a distance from the projection 852. The aperture 878 may be positioned on the disk side wall 859 if necessary, such as if the drink opening 828 of the cover 812 is positioned on the cover side wall 816. The aperture 878 could be formed merely by forming a slot or channel in the peripheral edge 851 of the element 850.

[0251] A disk recessed portion 884 is preferably positioned about the projection 852 and the aperture 878. The degree of recess of the portion 884 can vary. Although the recessed portion 884 is shown positioned on a portion of both the disk side wall 859 and the disk top wall 856, the recessed portion 884 can be limited to either the side wall 859 or the top wall 856. The recessed portion 884 is adapted to be received by an inner surface of the recessed portion 840 of the cover 812 when the element 850 is positioned proximate the cover 812. The position of the recessed portion 884 of the element 850 is similar to the position of the recessed portion 840 of the cover 812.

[0252] An indentation 881 is located in the center 862 of the disk top wall 856, and is one preferred mechanism for rotatably mounting the disk 850 on the support member 837. As discussed, several structures can be used to rotatably support the element 850 on the cover 812. The indentation 881 illustrated in FIG. 26 is cylindrical in shape, and has an indentation edge 883 and an inner side wall 885. Alternatively, the indentation 881 may have a more complex shape, or may simply comprise an aperture. The support member 837 and the indentation 881 are cooperatively dimensioned such that they are in rotational engagement with each other. Preferably, the support member 837 and the indentation 881 engage each other with an interference fit between the inner side wall 883 of the indentation 881 and the outer side wall 837b of the support member 837, as illustrated in FIG. 27.

[0253] Referring to FIG. 23, the element 850 and the cover 812 are cooperatively dimensioned such that the element 850 can be positioned within the interior region defined by the cover 812, to comprise an "assembled position," wherein the element 850 is rotatably mounted on the support member 837. As further shown in FIGS. 23, 27 and 28, the element 850 is attached to the support member 837 in such a way that the element 850 is held in place, while having at least some freedom to rotate in either direction. Preferably, as described

above, the support member 837 and the indentation 881 are cylindrically shaped and engage each other with an interference fit. Other structures could be added to the support member 837 and indentation 881 to enhance the rotatable connection. However, many other mechanisms for rotatably mounting the element 850 upon the support member 837 exist, and the present invention is not intended to be limited to any particular mechanism for rotational engagement between the element 850 and the cover 812. In one alternative embodiment, the support member 837 contains or comprises a lip or cusp for holding the disk in place, eliminating the necessity for an interference fit. In another possible embodiment, the support member 837 consists of only an aperture, and the disk contains a cooperatively dimensioned projection that extends through the aperture to support the disk, rather than an indentation. Furthermore, it is understood that the male/female aspects of the support member 837 and indentation 881 could be reversed on the cover 812 and element 850. The key aspect of the present invention is not the structure of the mounting mechanism, but the use of a moveable element rotatably mounted by a support member.

[0254] In the assembled position, the actuator 854 is accessible by a user through the slot 830. In the preferred embodiment, the element 850 is positioned proximate the cover 812 such that at least a portion of the post 854 is received by and extends through the slot 830. In this configuration, the element 850 is positioned beneath the cover 812 such that the center portion 836 of the cover 812 is proximate the center portion 862 of the element 850. The actuator 854 may take one of many other forms, but regardless of the form of the actuator, it is accessible through the slot 830.

[0255] In the assembled position, the element 850 is movable by rotating between a first, or closed, position and a second, or open, position. The element 850 is moved between the first and second positions P1, P2 by manipulation of the actuator 854 by a user. In the first position P1, as shown in FIG. 23, the projection 852 is received by the drink opening 828 such that the opening 828 is sealed and the lid 810 is closed. When the opening 828 is sealed, the edge 829 of the opening 828 is in frictional engagement with the projection 852. The top portion of the projection 852 can extend past the edge 829 of the drink opening 828. This seal prevents the flow of the flowable substance in the container 825 through the opening 828, enabling the container 825 and lid 810 to be moved without risking spillage. Also, in the first position P1, the recessed portion 862 of the element 850 is engaged with the recessed portion 836 of the cover 812. In addition, in the first position P1, the aperture 878 is misaligned or offset from the opening 828. Alternatively, the projection 852 and the opening 828 are in a snap fit engagement wherein each have sufficient structure to enable the snap fit engagement. Other cooperating structures can also be utilized.

[0256] In an alternate configuration of the element 850, the projection 852 is omitted (not shown), and the top wall surface 856 is substantially flat. In the first position P1, the flat top wall 856 surface of the element 850 is aligned with the opening 828 in a surface-to-surface engagement such that the opening 828 is sealed.

[0257] In the second position P2, the aperture 878 is aligned with the drink opening 828 to form a passageway between the element 850 and the cover 812 wherein the lid 810 is open, as illustrated in FIG. 28. The passageway permits the passage or flow of the flowable substance held by the container 825 through the lid 810. When the lid 810 is in the second position

P2, at least a portion of the aperture 878 is aligned with at least a portion of the edge 829 of the drink opening 828. In addition, in the second position P2, the projection 852 is misaligned with, or offset from, the opening 828. When the aperture 878 is partially aligned with the drink opening 828, the passageway remains but its dimensions are reduced. When the aperture 878 is completely misaligned with the drink opening 828, the passageway is eliminated. When the aperture 878 is completely misaligned with the drink opening 828 and the projection 852 is received in the opening 828, the opening 828 is sealed and the lid 810 is in the first position, P1. Alternatively, if no projection is present, the element 850 is returned to the first position P1 wherein the aperture 878 is completely misaligned with the drink opening 828, and the opening 828 is sealed.

[0258] A user can move the element 850 between the first position P1 and the second position P2 by manipulating the actuator 854. In the preferred embodiment, this is done by grasping and actuating or manipulating the post 854 between the first end 830a of the slot 830 and the second end 830b of the slot 830. Referring to FIG. 23, when the post 854 is proximate the first end 830a, the element 850 is in the first position P1. Conversely, referring to FIG. 28, when the post 854 is proximate the second end 830b, the element 850 is in the second position P2. The post 854 can be located in a number of positions between the first and second ends, and as a result, the projection 852 can be misaligned with the opening to varying degrees.

[0259] As explained above, the element 850 can have a first and second aperture, wherein the apertures are positioned about the projection such as shown by the disk in FIG. 16. In this configuration, the disk can be rotated in either a clockwise or counter-clockwise direction to move the disk between a first position, in which the lid is closed, and a second position and a third position, in which the lid is open. In this position, the actuator is located close to the center of the slot, rather than at either end. When the disk is in the first position, rotating the disk in the clockwise direction brings the first aperture into alignment with the opening. Similarly, when the disk is in the first position, rotating the disk in the counter-clockwise direction moves the disk to the third position, bringing the second aperture into alignment with the opening. This feature further increases the flexibility and value of the lid.

[0260] Several additional embodiments of the lid of the present invention are further disclosed herein and described below.

[0261] FIGS. 29-36 disclose another embodiment of the lid, generally designated with the reference numeral 1010. The lid 1010 generally includes a cover 1012 and a moveable element 1050.

[0262] The cover 1012 has a top wall 1014 and a side wall 1016 depending from the top wall 1014. The top wall 1014 further has an opening 1028 and a slot 1030. The cover 1012 further has a mounting portion 1022 connected to the side wall 1016 that is configured to mount to a container or cup as shown in FIG. 29. The top wall 1014 further has a support member 1034 generally at a central portion 1017 of the top wall 1014. In one preferred embodiment, the support member 1034 is in the form of a depending post.

[0263] In this embodiment, the top wall 1014 of the cover 1012 is bi-leveled, as further shown in FIGS. 29 and 31. The top wall 1014 has an upper level 1013 and a lower level 1015. The relatively annular upper level 1013 is connected to the

relatively planar lower level 1015 by the tapering central portion 1017. This configuration provides a means of clearance for a nose of a user drinking from the container. The slot 1030 is located on the lower level 1015 and the opening 1028 is located on the upper level 1013. As further shown in FIGS. 29 and 31, the cover 1012 further includes a position indicator 1064 located on the top wall 1014 generally at the central portion 1017. The position indicator 1064 is described in greater detail below.

[0264] As further shown in FIGS. 29-33, the moveable element 1050 is rotatably mounted on the cover 1012. The moveable element 1050 is generally disk-shaped and has a projection 1052, an aperture 1078 (preferably a first aperture 1078 and a second aperture 1078), and an actuator 1054. The moveable element 1050 further has a central indentation 1081 that cooperates with the support member 1034 of the cover 1012 as described in greater detail below. Additionally, the moveable element 1050 is cooperatively dimensioned to accommodate the bi-leveled top wall 1014 of the cover 1012. Like the cover 1012, the moveable element 1050 has a top wall 1056 that has a relatively annular upper level 1055 and a relatively planar lower level 1057 connected by a tapering central portion 1059.

[0265] As shown in FIGS. 29, 30 and 33, the moveable element 1050 is rotatably mounted on the cover 1012. Preferably, the moveable element 1050 is mounted on the support member 1034 wherein the indentation 1081 of the moveable element 1050 is received by the support member 1034 of the cover 1012. The indentation 1081 is dimensioned so as to fit around the support member 1034. However, the moveable element 1050 may be rotatably mounted on the support member 1034 by any other known means as well as those methods described herein. Once properly mounted, the actuator 1054 is received by the slot 1030. In the assembled lid 1010, the actuator 1054 is accessible through the slot 1030.

[0266] The moveable element 1050 is moveable between a first position and a second position by rotation of the moveable element 1050 about the support member 1034. FIGS. 29 and 30 show the lid 1010 in the first position defining a closed position. In the closed position, the projection 1052 is positioned within the opening 1028. The apertures 1078 are misaligned with the opening 1028. Also, the position indicator 1064 indicates to the user that the lid 1010 is in the closed position. The indicator 1064 is aligned with the actuator 1054 to indicate the closed position. As shown in FIG. 34, the moveable element 1054 is rotatably moveable to the second position such as by a user manipulating the actuator 1054. The second position defines an open position wherein the aperture 1078 is aligned with the opening 1028 wherein a flowable substance can pass therethrough. In this position, the actuator 1054 is positioned to one end of the slot 1030 wherein the actuator 1054 is misaligned with the position indicator 1064. As further shown in FIG. 35, because the moveable element 1054 has a second aperture 1078, the actuator 1054 can be rotated in an opposite direction than as shown in FIG. 34, wherein the actuator 1054 is rotated to an opposite side of the slot 1034. In this position, the other aperture 1078 is aligned with the opening 1028. Thus, the moveable element 1054 can be rotated in either a clockwise direction or a counterclockwise direction to place the moveable element 1054 in the second, open position.

[0267] It is understood that the position indicator 1064 and the actuator 1054 have first and second positional relationships with respect to one another when the lid is in the closed



and open positions. In the present embodiment, the closed position is indicated by the position indicator 1064 being aligned with the actuator 1054. The open position is indicated by misalignment of the indicator 1064 and the actuator 1054. It is understood, however, that this configuration could be reversed wherein an aligned configuration could indicate an open position and a misalignment could indicate a closed position. It is further understood that the indicator 1064 may take other forms.

[0268] FIGS. 37-43 disclose another embodiment of the lid of the present invention. The lid 1110 generally includes a cover 1112 and a moveable element 1150.

[0269] As further shown in FIGS. 37-39, the cover 1112 has a top wall 1114 and a depending side wall 1116. The cover 1112 further has an opening 1128, a slot 1130, a mounting portion 1122, and a support member 1134. The opening 1128 is preferably in the top wall 1114 but could be in other locations such as the side wall 1116. The support member 1134 protrudes, rather than depends, from the top wall 1114, and the support member 1134 is located near an edge 1160 of the top wall 1114, rather than in the center, as illustrated in FIGS. 37-43. As described in greater detail below, the moveable element 1150 is pivotally mounted on the support member 1134.

[0270] Preferably, the support member 1134 for this embodiment is a protrusion from the top wall 1114, which receives a member projecting from the moveable element 1150. Alternately, the support member 1134 can have any one of the many possible configurations already discussed herein. The slot 1130 in the top wall 1114 provides access to an actuator associated with the moveable element 1150 and allows the moveable element 1150 to pivot between the open and closed positions. As further shown in FIG. 37, the cover 1112 may have indicators for additives that may be included with flowable contents contained in the container, generally designated "S;" (sugar) and "C" (cream). Other indicators, such as "D" (decaf) may also be included.

[0271] As shown in FIG. 40, the moveable element 1150 of the lid 1110 includes a knob 1151 and an actuator 1154 affixed to an appendage 1148. The appendage 1148 is an elongated finger-type member rather than being disk-shaped. Preferably, the moveable element 1150 has no aperture, and opens and closes the lid 1110 by blocking or moving away from the opening 1128, creating an open position and a closed position. Alternately, the moveable element 1150 contains an aperture (not shown). The moveable element 1150 can also contain a projection 1152 for sealing the opening 1128 when the moveable element 1150 is in the closed position. The moveable element 1150 is pivotably mounted on the support member 1134. Preferably, and as can be appreciated from FIGS. 41-43, the knob 1151 fits inside the support member 1134, forming an interference fit, allowing the moveable element 1150 to pivot between the open and closed positions. Nearly any means discussed herein of rotatably mounting a moveable element 1150 on a support member 1134 will function to pivotably mount a moveable element 1150 as well. Thus, a wide range of mounting configurations are available.

[0272] As shown in FIGS. 41-43, the lid 1110 is moveable between an open position and a closed position by the user manipulating the actuator 1154, which is accessible through the slot 1130. The appendage 1148 of the moveable element 1150 is preferably a generally elongated member, as illustrated in FIG. 40. In the closed position, illustrated in FIGS. 37 and 38, the tip of the appendage 1148 obstructs the open-

ing 1128. The actuator 1154 is positioned at an end of the slot generally towards a central portion of the cover 1112. In the open position, illustrated in FIGS. 42 and 43, the appendage 1148 is pivoted away from the opening 1128, allowing a flowable substance to pass through. A user forces the actuator 1154 to an opposite end of the slot 1130 generally towards an outer edge of the container 1112. Thus, the actuator 1154 moves to and from a center portion of the cover 1112 or to and from an outer edge of the cover 1112. This movement pivots the moveable element 1150 about the support member 1134. The slot 1130 of this embodiment is fairly short in length, since the proximity of the actuator 1154 to the point of rotation requires a small movement for operation. The movement and location of the actuator 1154 of this embodiment favors the use of a trigger-shaped actuator 1154, rather than the standard post described above. It is understood that the location of the support member 1134 could vary to accommodate different shapes of pivoting moveable members 1150.

[0273] FIGS. 44-47 disclose another embodiment of the lid of the present invention, generally designated with the reference numeral 1210. The lid 1210 generally includes a cover 1212 and a moveable element 1250.

[0274] The cover 1212 has an opening 1228, a slot 1230, a mounting portion 1218, and a support member 1234 depending from a center of the top wall 1214. The top wall 1214 has a central recessed portion. The support member 1234 is generally in the form of a post. As described in greater detail below, the moveable element 1250 is rotatably mounted on the support member 1234. The slot 1230 is a large slot 1230 and extends about a half of the circumference of the cover 1212, and further extends to both the top wall 1214 and sidewall 1216 of the cover 1212. Further, the cover 1212 contains a stop 1270 (FIG. 47) that constrains the rotation of the moveable element 1250 as described in greater detail below.

[0275] As shown in FIGS. 46-47, the moveable element 1250 has a central recessed portion that corresponds to the central recessed portion of the cover 1212. The moveable element 1250 has an indentation 1281 that defines a recess. As explained in greater detail below, the indentation 1281 receives the support member 1234 of the cover 1212 for rotatable support. The moveable element 1250 further has an aperture 1278 and a projection 1252 on each side of the aperture 1278. The aperture 1278 and projections are located on a frontal segment of the moveable element 1250. Finally, the moveable element 1250 has an actuator 1254 accessible through the slot 1230. The actuator 1254 extends around a circumference of the element and is spaced from the frontal segment. Generally, the moveable element 1250 is contoured to correspond in shape with the inside structure of the cover 1212.

[0276] The actuator 1254 defines an extended side wall 1261 opposite the aperture 1278. The actuator 1254 has recesses 1269 on the side wall 1261 to form a gripping element 1268 to enhance the grippability of the actuator 1254. To accommodate this extended side wall 1261, the slot 1230 in the cover 1212 extends through a portion of the cover top wall 1214 and through most of the height of the cover side wall 1216, stretching for nearly half the circumference of the cover 1212. The configuration of this embodiment of the present invention provides a large area of access to the actuator 1254.

[0277] As shown in FIGS. 46 and 47, the moveable element 1250 is preferably rotatably supported by the cover 1212. The moveable element 1250 is positioned within the cover 1212

wherein the indentation 1281 receives the support member 1234. The indentation 1281 is dimensioned so as to fit around the support member 1234. However, the moveable element 1250 can be rotatably mounted on the support member 1234 by any means described herein. As discussed and disclosed, the overall contour of the moveable element 1250 generally corresponds to the inner surface of the cover 1212.

[0278] The moveable element 1250 of the lid 1210 illustrated in FIGS. 44-47 is moveable between an open position and a closed position. As shown in FIG. 45, when the aperture 1278 that is cooperatively dimensioned with the opening 1228, is aligned with the opening 1228 on the cover 1212, the lid 1210 is in the “open” position. As discussed, the projections 1252 are located on either side of the aperture 1278. When a user engages the actuator 1254 and rotates the moveable element 1250, one of the projections 1252 is aligned with the opening 1228, wherein the opening 1228 is obstructed and the lid 1210 is in the closed position. The gripping element 1268 of the actuator 1254 assists the user in rotating the moveable element 1250. It is understood that the moveable element 1250 can be rotated in an opposite direction wherein the other projection 1252 will be aligned with the opening 1228 to also create a closed lid position. Thus, the lid 1210 has two closed positions and one open position. Accordingly, as illustrated and described, the lid 1210 can be moved from one closed position, where the aperture 1278 is located to the left of the opening 1228, to the open position, and to the other closed position, where the aperture 1278 is located to the right of the opening 1228, by rotation.

[0279] As can be understood by FIGS. 44-47, the slot 1230 does not constrain the rotation of the moveable element 1250, because the actuator 1254 does not project through the slot 1230. Accordingly, the lid 1210 has at least one stop 1270 to constrain rotation of the moveable element 1250. As shown in FIGS. 46 and 47, the stop 1270 preferably comprises a tab 1271 on the inner surface 1232 of the cover 1212. The stop 1270 shown in FIGS. 46-47 is aligned with the center of the opening 1228, and the moveable element 1250 has a notch 1272 aligned with the center of the aperture 1278, such that the tab 1271 will sit within the notch 1272, partially constraining the rotation of the moveable element 1250, when the aperture 1278 and the opening 1228 are aligned. Thus, the lid 1210 will be “locked” in the open position, and small forces exerted on the lid 1210, resulting from jostling or bumping, will not move the lid 1210 from the open position. The lid 1210 may additionally or alternately include stops (not shown) to the left and/or right of the opening 1228 to create other partially constrained (“locked”) positions, or to totally constrain rotation of the moveable element 1250 beyond certain points of rotation. Alternately, a stop 1270 may both partially and totally constrain rotation of the moveable element 1250, as may be desired.

[0280] As illustrated in FIGS. 5-8, the moveable element used to seal and open the lid may be an overlay (e.g. the overlay 250) rather than being positioned on the interior of the lid. However, other means of mounting the overlay on the cover exist beyond those previously illustrated and described. FIGS. 48-58 disclose additional embodiments utilizing rotatable overlay elements. It will be understood that the several embodiments share common features that will be designated with similar reference numerals. The lid disclosed in FIGS. 48-51, generally designated with the reference numeral 1310, will be described in greater detail. As there are many structural similarities, this detailed description will also apply to

the other embodiments such as in FIGS. 52-53 (utilizing “1310a” reference designations), FIGS. 54-55 (utilizing “1310b” reference designations) and FIGS. 56-58 (utilizing “1310c” reference designations). Other distinguishing features of each embodiment will also be described.

[0281] As shown in FIGS. 48-51, the lid 1310 generally includes a cover 1312 and a moveable element in the form of a rotatable overlay 1350. As explained in greater detail below, the overlay 1350 is rotatably supported on a track of the cover 1312.

[0282] The cover 1312 generally has a top wall 1314, a side wall 1316 depending from the top wall 1314, a mounting portion 1322 at the base of the side wall 1316 and an opening 1328. The top wall 1314 also has a recessed central portion 1336. The cover 1312 further defines a track 1342 that rotatably supports the overlay 1350. As shown in FIGS. 48 and 51, the track 1342 is preferably annular, and most preferably comprises an annular cusp 1343 extending around the entire circumference of the cover 1312. The cusp 1343 is positioned on the outside of the side wall 1316 and preferably extends from a portion of the mounting portion 1322. The track 1342 is defined generally between the cusp 1343 and a portion of the mounting portion 1322.

[0283] The overlay 1350 generally has a similar contoured shape as the cover 1312. As shown in FIGS. 48 and 50, the overlay 1350 has a top wall 1356 and a depending side wall 1359. The overlay 1350 has a recessed central portion 1362 cooperatively dimensioned with the recessed central portion 1336 of the cover 1312. Additionally, the overlay 1350 preferably has at least one aperture 1378, which is aligned with the opening 1328 in the open position, providing access to the opening 1328. The aperture 1378 is preferably a cut-away portion 1378 of the overlay 1350, but is alternately a small hole or slot in the overlay 1350. Preferably, the overlay 1350 has two apertures 1378 that create a finger 1367 therebetween. The finger 1367 is adapted to seal the opening 1328 in the closed position. In one embodiment, the finger 1367 is connected to the overlay 1350 at both ends, as illustrated in FIGS. 48-51. The overlay 1350 further has an annular flange 1346 extending from the side wall 1359 of the overlay 1350. The annular flange 1346 is dimensioned to fit in the track 1342 as described in greater detail below.

[0284] Further, the overlay 1350 preferably has an actuator 1368 in the form of a gripping element 1368 to facilitate gripping and manipulating the overlay 1350, such as one or more ridges. Finally, the overlay 1350 preferably includes a projection 1352, which projects from the bottom surface of the overlay 1350, and preferably at the finger 1367. The projection 1352 fits within the opening 1328 when the lid 1310 is in the closed position, sealing the opening 1328.

[0285] As can be appreciated from FIGS. 50-51, the overlay 1350 fits over the cover 1312. As discussed, the overlay 1350 is rotatably supported in the track 1342 of the cover 1312. The annular flange 1346 on the overlay 1350 is received in the track 1342. The cusp 1343 engages the flange 1346 as shown in FIG. 51. The cusp 1343 holds the overlay 1350 close to the top of the lid 1310 while allowing it the freedom to rotate relative to the cover 1312.

[0286] Notably, while the track 1342 for mounting the overlay 1350 is preferably annular, the structure or structures creating the track 1342 need not be. For example, the annular track 1342 may alternately comprise several intermittently spaced cusps (not shown) around the circumference of the sidewall, the flange 1346 being interlocked with the cusps.

Similarly, the track **1342** may only extend for a portion of the perimeter of the cover **1312**. Finally, the track **1342** need not be annular, although an annular track **1342** is preferable, and any configuration of the track **1342** allowing the overlay **1350** to be rotatably mounted on the cover **1312** is effective. Still other embodiments and configurations are possible.

[0287] As with the previous embodiments, the lid **1310** has a closed position and an open position. The closed position is shown in FIG. **48** wherein the finger **1367** is proximate and covering the opening **1328**. Furthermore, the projection **1352** is received in the opening **1328**. As shown in FIG. **49**, a user rotates the overlay **1350** such as by engaging the actuator **1368** wherein the aperture **1378** is generally aligned with the opening **1328** to allow a flowable substance to flow through the opening **1328**. It is understood that a user could rotate the overlay **1350** in an opposite direction wherein the other aperture is aligned with the opening **1328**. When moving between the open and closed positions, the overlay **1350** rides in the track **1342** of the cover **1312**.

[0288] FIGS. **52-53** disclose another embodiment of the lid using a rotatable overlay, generally designated with the reference numeral **1310a**. The lid **1310a** has similar features to the lid **1310** of FIGS. **48-51**. As shown in FIGS. **52** and **53**, the lid **1310a** has a recessed central portion. The overlay **1350a** has an open central portion **1347** and preferably has a generally toroidal shape, i.e. a three-dimensional ring wherein the recessed central portion of the cover **1312a**. The cover **1312** has a top wall **1314a** that defines an additional annular track. The overlay **1350a** also has a top wall **1356a** that corresponds to the top wall **1314a** of the cover **1312a**. The top wall **1356a** is also rotatably supported by the top wall **1356a** of the cover **1312a**, as the overlay **1350a** rides along the annular track defined by the top wall **1314a** of the cover **1312a**. The overlay **1350a** also has apertures **1378a** separated by the finger **1367a**. In this embodiment, the finger **1367a** extends upwards from a base of the overlay **1350a** and does not extend across the central portion of the overlay **1350a**. The finger **1367a** has a distal end that rides over the top wall **1314a** of the cover **1312**.

[0289] FIG. **52** shows the open position wherein the overlay **1350a** is rotated such that the finger **1367** is spaced from the opening **1328a** and one of the apertures **1378a** is aligned with the opening **1328a**. In this position, the side wall of the cover **1312** has a “close” indicia thereon indicating a direction of rotation for the overlay **1350a** to close the lid **1310a**. FIG. **53** shows the overlay **1350a** rotated such that the finger **1367** obstructs the opening **1328a**. In this position, the side wall of the cover **1312** has an “open” indicia thereon indicating a direction of rotation for the overlay **1350a** to open the lid **1310a**.

[0290] FIGS. **54-55** show another embodiment of the lid utilizing a rotatable overlay, the lid being generally designated with the reference numeral **1310b**. The structure is similar as described above. The overlay **1350b** has larger ridges **1368b** than in the previous embodiments. The overlay **1350b** has cut-away portions or apertures **1378b** wherein the finger **1367b** extends therebetween. As shown in FIGS. **54-55**, the cover **1312b** includes one or more stops **1370** for constraining rotation of the overlay **1350b**. The stops **1370** may partially constrain rotation of the overlay **1350b**, by creating one or more “locked” positions, or may totally constrain rotation of the overlay **1350b**, or may do both. For example, the stops **1370** of the lid **1310b** illustrated in FIGS.

**54-55** totally constrain rotation of the overlay **1350b** in one direction. Many other stop configurations are possible to achieve the same effect.

[0291] FIG. **54** shows the lid in a closed position wherein the finger **1367b** obstructs the opening **1328b**. FIG. **55** shows the overlay **1350b** rotated wherein the lid is in the open position. In this position, an edge portion of the overlay **1350b** engages the stop **1370** to prevent further rotation of the overlay **1350b**. It is understood that the other stop **1370** is used to engage another edge portion of the overlay **1350b** if the overlay **1350b** is rotated in an opposite direction.

[0292] FIGS. **56-58** show yet another embodiment utilizing a rotatable overlay, the lid being designated with the reference numeral **1310c**. In this embodiment, the track **1342c** is located in the top wall **1314c** of the cover **1312c**, rather than in the side wall **1316c**. The overlay **1350c** is annular and generally ring-shaped. The overlay **1350c** has an aperture **1378c** to expose the opening **1328c**, and rotates while mounted on the annular track **1342c** in the top wall **1314c**. The overlay **1350c** has an actuator in the form of a plurality of upstanding ridges **1368c**. FIG. **56** shows the lid **1310c** in the open position. FIG. **56** shows the lid **1310c** with the overlay **1350c** rotated wherein the lid **1310c** is in the closed position. FIG. **58** shows a cross-sectional view of the overlay **1350c** mounted on the cover **1312c**.

[0293] FIGS. **59-65** disclose yet additional embodiments of lids utilizing rotatable overlay elements having alternate mounting structures. It will be understood that the several embodiments have similar structural features that will be designated with similar reference numerals. The lid disclosed in FIGS. **59-61**, generally designated with the reference numeral **1410**, will be described in greater detail. This detailed description will also apply to the other embodiments such as in FIGS. **62-63** (utilizing “**1410a**” reference designations) and FIGS. **64-65** (utilizing “**1410b**” reference designations). Other distinguishing features of each embodiment will also be described.

[0294] As shown in FIGS. **59-61**, the lid **1410** generally includes a cover **1412** and an overlay **1450** rotatably supported on the cover **1412**.

[0295] The cover **1412** has a top wall **1414**, a hub **1434** located in the top wall **1414**, a side wall **1416** depending from the top wall **1414**, and an opening **1428**. Preferably, the cover **1412** also has a mounting portion **1422** for mounting to a container. The top wall **1414** has a recessed central portion **1462**. The hub **1434** is preferably located in the recessed central portion **1462**. As further shown in FIGS. **59-61**, the hub **1434** is a knob **1498** on the top wall **1414** of the cover **1412**. The hub **1434** further has an annular groove **1476** extending almost a circumference on the hub **1434**. The cover **1412** further has status indicia **1465** located on the side wall **1416** of the cover **1412**. Preferably, the status indicia **1465** is an embossed “open” and/or “close” on the cover **1412**.

[0296] The overlay **1450** is rotatably mounted on the cover **1412** and has a top wall **1456** and a depending side wall **1461**. The overlay **1450** further has an outer surface **1475**, an inner surface **1474**. A connector **1480** is included on the top wall **1456**. The overlay **1450** preferably includes a gripping element **1468** on the side wall as in the embodiments discussed above. The connector **1480** of the overlay **1450** further has a tab portion **1477** that depends from the connector **1480** and fits within the annular groove **1476** of the hub **1434** described

in greater detail below. In this embodiment, the side wall **1461** of the overlay **1450** does not extend down the entire side wall of the cover **1412**.

[0297] The overlay **1450** has a cut out portion, or aperture **1478**, that defines a pair of fingers **1467**. The fingers **1467** have a projection **1452** thereon that seals the opening **1428** when the lid **1410** is in the closed position.

[0298] In some embodiments, as discussed above, the overlay **1450** has a position indicator **1464**. This position indicator **1464** may take any of the forms previously discussed, but preferably is a pointer **1466** on the overlay **1450** that points to one or more status indicia **1465** on the cover **1412**. In a preferred embodiment, the position indicator **1464** depends from one of the fingers **1467**. The status indicia **1465** communicates the position of the lid **1410** in a variety of different ways, as discussed above. The shape of the overlay **1450** is preferably asymmetrical, as shown in FIGS. **59-65**, but may be symmetrical as well.

[0299] The hub **1434** and connector **1480** may have one of a number of different forms, allowing the overlay **1450** to be rotatably mounted on the hub **1434**. As illustrated in FIGS. **59-61**, the overlay **1450** is positioned over the cover **1412**. The tab portions **1477** on the overlay **1450** fit into the annular groove **1476** as shown in FIG. **61**. The tab portions **1477** can slide within the groove **1476** when the overlay **1450** is rotated. As shown, the overlay **1450** is cooperatively dimensioned wherein the top wall **1456** and side wall **1461** of the overlay confronts the top wall **1414** and side wall **1416** of the cover **1412**. Other structures for connecting the overlay **1450** to the cover **1412** are also possible.

[0300] As discussed above, the lid **1410** may incorporate stops to partially constrain rotation of the overlay **1450**. The stops may create one or more “locked” positions, or may totally constrain rotation of the overlay **1450**, or may do both. The stops can be one of the embodiments previously described or be incorporated into the hub/tab connecting portions between the cover **1412** and the overlay **1450**.

[0301] As with the previous embodiments, the lid **1410** has a closed position and an open position. The closed position is shown in FIG. **59** wherein the finger **1467** is proximate and covering the opening **1428**. Furthermore, the projection **1452** is received in the opening **1428**. Also, the pointer **1466** of the position indicator **1464** is aligned with the “close” indicia **1465**. As shown in FIG. **60**, a user rotates the overlay **1450** such as by engaging the actuator **1468** wherein the aperture **1478** is generally aligned with the opening **1428** to allow a flowable substance to flow through the opening **1428**. In this position, the pointer **1466** of the position indicator **1464** is aligned with the “open” indicia **1465**. It is understood that a user could rotate the overlay **1450** in an opposite direction to close the lid **1410**. When moving between the open and closed positions, the overlay **1450** rides in the track or groove **1476** of the cover **1412**.

[0302] FIGS. **62-63** disclose another embodiment of the lid utilizing a center-mounted overlay, the lid generally being designated with the reference numeral **1410a**. The lid **1410a** has the cover **1412a** and the overlay **1450a**. The cover **1412a** has the hub **1434a** that is an indentation **1481a** in the top wall **1414a** of the cover **1412a**. The overlay **1450a** has the connector **1480a** in the form of a knob **1451a** on the inner surface **1474a** of the overlay **1450a**. In such a configuration, the indentation **1481a** is cooperatively dimensioned with the knob **1451a** such that the knob **1451a** fits within the indentation **1481a**, securing the overlay **1450a** to the cover **1412a**

and permitting rotation of the overlay **1450a** between the open position and the closed position. This mounting configuration is similar to that illustrated above with respect to other embodiments, such as in FIG. **33**.

[0303] It is further appreciated that the top wall **1414a** of the cover **1412a** defines an annular rail structure generally at a rear periphery of the cover **1412a**. The cover **1412a** further has indicia indicators **1465a** on the side wall **1416a** of the cover **1412a**. As discussed in greater detail below, stops **1470a** are located on the top wall **1414a** of the cover **1412a**.

[0304] The overlay **1450a** in FIGS. **62-63** has a first end **1482a** and a second end **1483a** on opposing sides of the connector **1480a**. The width of the overlay **1450a** is greater at the first end **1482a** than at the second end **1483a**. The overlay **1450a** narrows such that a point **1466a** is created and serving as a position indicator **1464a**. A distal end of the second end **1483a** extends downward along the side wall **1416a** of the cover **1412a**.

[0305] As discussed, the cover **1412a** includes one or more stops **1470a** for constraining rotation of the overlay **1450a**. The stops **1470a** of the lid **1410a** illustrated in FIGS. **62-63** totally constrain rotation of the overlay **1450a** in one direction (not allowing it to move past a certain point), but also frictionally engage notches **1472a** in the overlay **1450a** to “lock” the overlay **1450a** in the open position, partially constraining its rotation in the other direction. It is appreciated that there are two pairs of stop/notch structures for restraining rotation of the overlay **1450a** in either direction.

[0306] The lid **1410a** has a closed position and an open position. The closed position is shown in FIG. **62** wherein the finger **1467a** is proximate and covering the opening **1428a**. Furthermore, the projection **1452a** is received in the opening **1428a**. Also, the pointer **1466a** of the position indicator **1464a** is aligned with the “close” indicia **1465a**. It is further shown that additional ribs could be located on the side wall **1416a** of the cover **1412a** above the indicia **1465a**. The pointer **1466a** rests between the ribs in the closed and open positions. As shown in FIG. **63**, a user rotates the overlay **1450a** such as by engaging the actuator **1468a** wherein the finger **1467a** is spaced from the opening **1428a** to allow a flowable substance to flow through the opening **1428a**. In this position, the pointer **1466a** of the position indicator **1464a** is aligned with the “open” indicia **1465a**. It is further understood that the notch **1472a** is received by the stop **1470a** to prevent further rotation of the overlay **1450a**. It is understood that a user could rotate the overlay **1450a** in an opposite direction to close the lid **1410a**. It is further shown that the overlay **1450a** could have direction indicia on the top wall of the overlay **1450a**, such as in the form of arrows.

[0307] FIGS. **64-65** disclose yet another embodiment, generally designated with the reference numeral **1410b**. The hub **1434b** is a knob **1498b** on the top wall **1414b** of the cover **1412b** and the connector **1480b** is an indentation **1499b** in the inner surface of the overlay **1450b**. The indentation **1499b** is cooperatively dimensioned with the knob **1498b** such that the knob **1498b** fits within the indentation **1499b**, securing the overlay **1450b** to the cover **1412b** and permitting rotation of the overlay **1450b** between the open position and the closed position. The overlay **1450b** shown in FIGS. **64-65** has a narrow, finger-like end **1483b** with a projection **1452b** for sealing the opening, allowing the lid **1410b** to be opened with a smaller rotation of the overlay **1450b**, while having a wider end **1482b** opposite the projection, to create a more effective

gripping surface. It is appreciated that the overlay **1450b** is rotated in either direction to place the lid **1410b** in open and closed positions.

[0308] FIGS. **66-68** disclose another alternate embodiment of the lid of the present invention, generally designated with the reference numeral **1610**. In this embodiment, the lid **1610** generally includes a cover **1612** and a moveable member or moveable element **1650**.

[0309] The cover **1612** has a top wall **1614**, a side wall **1616**, a mounting portion **1622**, an opening **1628** and a support member **1634**. Preferably, as illustrated in FIGS. **66-68**, the support member **1634** is a pair of notches **1633** in the top wall **1614** of the cover **1612**. The top wall **1614** further has a protuberance **1686**. The moveable element **1650** has a base portion having a pair of pegs **1651**. The moveable element **1650** further has a plug **1652** located in an extension member that extends from the base. Opposite the plug **1652**, the moveable element **1650** has a recess **1687**.

[0310] As shown in FIGS. **66-68**, the moveable element **1650** is pivotally mounted to the cover **1612** wherein the element **1650** cooperates with the support member **1634**. Specifically, the two pegs **1651** on the moveable element **1650** “snap” into the notches **1633** on the cover **1612**. Alternately, the support member **1634** takes a different form (not shown), wherein the moveable element **1650** is more permanently attached to the cover **1612**. Additionally, the peg **1651** can have a more complex shape, such as a cross-shaped peg (not shown) that may be pivotally mounted on a cooperatively-shaped support member. Many other cooperative configurations are possible.

[0311] As shown by the arrows in FIG. **66**, the moveable element **1650** pivots within the notches **1633** between an open position and a closed position. FIG. **66** disclosed the closed position wherein the plug **1652** is received in the opening **1628** for sealing the opening **1628**. FIG. **67** discloses the open position wherein the moveable element **1650** is pivoted away from the opening **1628**. The pegs **1651** rotate within the notches **1633** to allow for the pivotal movement. As further shown in FIG. **67**, the recess **1687** engages the protuberance **1686** on the cover **1612** to lock the lid **1610** in the open position.

[0312] FIGS. **69-71** disclose another embodiment of the lid of the present invention, generally designated with the reference numeral **1710**. The lid **1710** generally includes a cover **1712** and a moveable element **1750**.

[0313] The cover **1712** has a top wall **1714**, a depending side wall **1716**, and a mounting portion **1722**, and an opening **1728**. The moveable element **1750** is mounted on the cover **1712**, preferably on the top wall **1714**. The moveable element **1750** preferably has a first segment **1790** permanently attached to the cover **1712** by a high-tack adhesive element **1791**, and a second segment **1792** releasably attached to the cover **1712** by a low-tack adhesive element **1793**. Preferably, the low-tack adhesive element **1793** is located on the second segment **1792** of the moveable element **1750**. Alternately, the low-tack adhesive element **1793** is located on the cover **1712**, preferably near or around the opening **1728**. The second segment **1792** is preferably positioned near the opening **1728** and the low-tack adhesive element **1793** releasably holds the second segment **1792** to the cover **1712**, sealing the opening **1728**. To open the lid **1710**, the second segment **1792** of the moveable element **1750** is pulled away from the cover **1712**, exposing the opening **1728**, while the first segment **1790** remains connected to the high-tack adhesive element **1791**.

The strength of the low-tack adhesive element **1793** is sufficient to hold the lid **1710** in a closed position, but not so great that the moveable element **1750** is difficult to separate from the cover **1712**. Additionally, the low-tack adhesive element **1793** preferably remains sticky after the lid **1710** is opened, allowing the lid **1710** to be re-sealed.

[0314] The high-tack adhesive element **1791** is not a necessary component of the lid **1710**, although it is preferably present. Accordingly, in another embodiment, the lid **1710** has a low-tack adhesive element **1793** releasably attaching at least a portion of the moveable element **1750** to the cover **1712**, with the high-tack adhesive element **1791** optionally present. If the high-tack adhesive element **1791** is not present, the moveable element **1750** can be permanently attached to the cover **1712** by any means described herein with respect to any other embodiment. For example, the moveable element **1750** may be tethered to the cover **1712**. Alternately, the moveable element **1750** is not permanently attached to the cover **1712**, being completely removable by releasing the low-tack adhesive element **1793**.

[0315] FIGS. **72-80** disclose yet additional embodiments of lids utilizing moveable members that are externally mounted and generally tethered to the cover. It will be understood that the several embodiments have similar structural features that will be designated with similar reference numerals. The lid disclosed in FIGS. **72-74**, generally designated with the reference numeral **1510**, will be described in greater detail. This detailed description will also apply to the other embodiments such as in FIGS. **75-76** (utilizing “**1510a**” reference designations), FIGS. **77-78** (utilizing “**1510b**” reference designations), and FIGS. **79-80** (utilizing “**1510c**” designations). Other distinguishing features of each embodiment will also be described.

[0316] As shown in FIGS. **72-74**, the lid **1510** generally includes a cover **1512** and a moveable element or moveable member **1550**.

[0317] The cover **1512** generally includes a cover **1512** having a top wall **1514**, a depending side wall **1516**, a mounting portion **1522** for mounting to a container, and an opening **1528**. The top wall **1514** has a recessed central portion **1515** and an annular ring portion **1517**. The top wall **1514** further has a protuberance **1586** that cooperates with the moveable element **1550** to be described below. In a preferred embodiment, the opening **1528** and the protuberance **1586** are located in the annular ring portion **1517** of the top wall **1514**.

[0318] The moveable element **1550** is tethered to the cover **1512**. In other words, the moveable element **1550** has one fixed end **1539** and one moveable end **1541**. The moveable element **1550** is tethered to the cover **1512** by a permanent or semi-permanent connection **1584**. The moveable element **1550** may be integrally molded with the cover **1512**, forming a single integral piece. Alternately, the moveable element **1550** is manufactured separately and attached to the cover **1512** by any acceptable means. Preferably, the moveable element **1550** is a flap or a strap having a plug **1552** that fits within the opening **1528**. The moveable element **1550** further has a recess **1587** that is dimensioned to cooperate with the protuberance **1586** of the cover **1512**. In the one preferred embodiment, the moveable element **1550** is shaped as a segment of a circle, preferably a semicircle. The moveable element **1550** has a hinge **1584**.

[0319] As further shown in FIGS. **72-74**, the moveable element **1550** is positioned within the central recessed portion of the top wall **1514**. The outer peripheral surface of the

moveable element 1550 abuts an inner surface defined by the annular ring portion 1517. The lid 1510 is tethered by the hinge 1584 across the top wall 1514 of the cover 1512. The hinge 1584 allows the moveable element 1550 to be pivoted about the hinge 1584.

[0320] As with the other embodiments, the moveable element 1550 is moveable to place the lid 1510 in a closed position and an open position. FIG. 72 shows the closed position. The moveable element 1550 is positioned along a front portion of the cover top wall 1514 wherein the plug 1552 is received in the opening 1528. FIG. 74 shows the moveable element 1550 moving from the closed position. The moveable element 1550 is pivotable about the hinge 1584. As shown in FIG. 73, the protuberance 1586 is received in the recess 1587 in the open position, locking the lid 1510 in the open position. Preferably, the protuberance 1586 and the recess 1587 are cooperatively dimensioned such that they are frictionally engaged with each other in the open position. Also, the moveable element 1550 preferably includes a tab 1523 or flange at the edge, facilitating the opening and closing of the lid 1510.

[0321] It is further understood that the moveable element 1550 of the lid 1510 of the present invention may function effectively having almost any shape or configuration. The moveable element 1550 may similarly be tethered to nearly any part of the cover 1512.

[0322] FIGS. 75-76 disclose another embodiment of the lid, generally designated with the reference numeral 1510a, wherein the moveable element 1550a is tethered to the cover 1512a.

[0323] As shown in FIG. 76, the cover 1512a has a channel 1588a extending across the top wall 1514a from a front portion to a rear portion. The opening 1528a is positioned in the top wall 1514a at the channel 1588a. The moveable element 1550a is tethered to the cover 1512a by a connection proximate the mounting portion 1522a of the cover 1512a. This connection could be integral or separately made. The moveable element 1550a has the first hinge 1584a having a curved portion. The moveable element 1550a further has a second hinge 1585a, also having a curved portion.

[0324] FIG. 76 shows the lid 1510a in the open position wherein the moveable member 1550a is pivoted about the first hinge 1584a and extends away from the cover 1512a. FIG. 75 shows the closed position. The moveable element 1550a is pivoted about the first hinge 1584a wherein the curved portion accommodates the mounting portion 1522a. The moveable element further pivots about the second hinge 1585a wherein the curved portion accommodates the interface between the cover side wall 1516a and the cover top wall 1514a. This configuration permits the moveable element 1550a to bend to conform to the shape of the cover 1512a to reduce the profile of the closed lid 1510a. The moveable member 1550a fits within the groove 1588a and the plug fits into the opening 1528a further enhancing the low profile characteristics of the lid 1510a.

[0325] FIGS. 77-78 disclose another embodiment, generally designated with the reference numeral 1510b, similar to the embodiment in FIGS. 75-76. The cover 1512b has a central recessed portion. The moveable element 1550b pivots about the first hinge 1584b and the second hinge 1585b. The moveable element 1550b extends across the central recessed portion of the cover top wall 1514b.

[0326] FIGS. 79-80 disclose another embodiment, generally designated with the reference numeral 1510c, similar in construction to the embodiments in FIGS. 75-78. The top wall

1514c has a central recessed portion 1515c. An annular ring portion 1517c is further defined in the top wall 1514c. In this embodiment, the moveable element 1550c has an enlarged portion 1553c that is generally in the form of a circle. The enlarged portion 1553c has an outer periphery that generally corresponds to the outer periphery defined by the annular ring portion 1517c of the top wall 1514c. Thus, as shown in FIG. 79, when the lid 1510c is in the closed position, the enlarged portion 1553c generally completely covers the top wall 1514c of the cover 1512c. FIG. 80 shows the lid 1510c in the open position.

[0327] FIGS. 81-99 disclosed several additional embodiments of the lid of the present invention utilizing a moveable member that generally moves along a track associated with the cover of the lid. The movement is generally axially along a straight line of motion or along a curved line of motion.

[0328] FIGS. 81 and 82 disclose a lid having a cover 1812 and a moveable member 1850. The cover has a top wall 1814, a side wall 1816 depending from the top wall 1814, a mounting portion 1822, a track 1842, and an opening 1828. The track 1842 preferably extends transversely across the cover 1814. Most preferably, the track 1842 extends transversely across the cover 1814, proximate a center line of the cover 1812. The cover has a front raised portion 1897 and a rear raised portion 1899. The front raised portion has a front passageway 1896 therethrough and the rear raised portion has rear passageway 1898. The passageways 1896, 1898 are cooperatively dimensioned with the moveable element 1850. The passageways 1896, 1898 cooperate to form portions of the track 1842.

[0329] Preferably, the moveable element 1850 is in the form of a strap that extends from the cover 1812 and along the track 1842. The moveable element 1850 contains a gripping element 1868 to facilitate gripping and otherwise manipulating the moveable element 1850 by a user. Additionally, the moveable element 1850 preferably contains a projection 1852 which seals the opening 1828 in the closed position.

[0330] As shown in FIGS. 81 and 82, the moveable element 1850 is tethered to the cover 1812. The moveable element 1850 is mounted on the track 1842. As discussed, one end of the moveable element 1850 is connected to the cover 1812. The free end of the moveable element 1850 is fed through the rear passageway 1898 and then through the front passageway 1896 wherein the member 1850 is moveable along the track 1842. The moveable element 1850 is axially slideable along the cover 1812.

[0331] The moveable element 1850 is moved between an open position and a closed position by sliding along the track 1842. Sliding occurs by the movement of the member 1850 back and forth along a single line of motion. Generally, this line of motion is straight. A user engages the gripping element 1868 to move the moveable element 1850 between the closed and open positions. FIG. 81 shows the lid 1810 in the closed position wherein the plug 1852 is received in the opening 1828. FIG. 82 shows the lid 1810 in the open position wherein the moveable element 1850 is slid along the track 1842 wherein the plug 1852 is spaced away from the opening 1828.

[0332] FIGS. 83-85 disclose another embodiment of the lid of the present invention designated with the reference numeral 1810a. The lid 1810a also utilizes a moveable element 1850a that slides along a track 1842a. The track 1842a is defined in the top wall 1814a wherein a raised portion defines a channel 1888a. The channel 1888a extends laterally

across the top wall **1814a**. As shown in FIGS. **83** and **85**, the channel **1888a** preferably has longitudinal grooves **1889a** on opposing sides.

[0333] The moveable element **1850a** is generally in the form of a strap. In this particular embodiment, the moveable element **1850a** is not tethered to the cover **1812a**. The moveable element **1850a** is dimensioned to cooperate with the channel **1888a**. Edges of the moveable element **1850a** are received in the longitudinal grooves **1889a**. The moveable element **1850a** has extension portions **1894a** that are received in the respective grooves **1889a** of the channel **1888a**. The moveable element **1850a** has a gripping element **1868a** in the form of a raised ridge on the element **1850a**.

[0334] As shown in FIGS. **83** and **84**, the moveable element **1850a** is slideable within the track **1842a** and channel **1888a** between closed and open positions. FIG. **83** shows the lid **1810a** in a closed position wherein the moveable element **1850a** is slid forward wherein the plug **1852a** is received in the opening **1828a**. FIG. **84** shows the lid **1810a** in an open position wherein the moveable element **1850a** is slid along the track **1842a** towards the rear of the cover **1812a** wherein the plug **1852a** is spaced from the opening **1828a**. The moveable element **1850a** is guided in the track **1842a**.

[0335] FIGS. **86-87** disclose another embodiment of the lid of the present invention designated with the reference numeral **1810b**. The lid **1810b** also utilizes a moveable element **1850b** that slides along a track **1842b**. The track **1842b** is defined in the top wall **1814a** wherein a raised portion defines a channel **1888b**. The channel **1888b** extends laterally across the top wall **1814b**. As shown in FIG. **86**, the channel **1888b** preferably has longitudinal grooves **1889b** on opposing sides.

[0336] The moveable element **1850b** is generally in the form of a strap. In this particular embodiment, the moveable element **1850b** is tethered to the cover **1812b**. The moveable element **1850b** is connected to the side wall **1816b** of the cover **1812b**. The moveable element **1850b** is dimensioned to cooperate with the channel **1888b**. As shown in FIGS. **86** and **87**, the moveable element **1850b** is slideable within the track **1842b** and channel **1888b** between closed and open positions. FIG. **87** shows the lid **1810b** in a closed position wherein the moveable element **1850b** is slid forward wherein the plug **1852b** is received in the opening **1828b**. FIG. **86** shows the lid **1810b** in an open position wherein the moveable element **1850b** is slid along the track **1842b** towards the rear of the cover **1812b** wherein the plug **1852b** is spaced from the opening **1828b**. The moveable element **1850b** is guided in the track **1842b**.

[0337] FIGS. **88-89** disclose another embodiment of the lid of the present invention designated with the reference numeral **1810c**. The lid **1810c** also utilizes a moveable element **1850c** that slides along a track **1842c**. The track **1842c** is defined in the top wall **1814c** wherein a raised portion defines a channel **1888c**. The channel **1888c** extends laterally across the top wall **1814c**. The channel **1888c** has a generally narrowing section **1899c** as the channel **1888c** extends towards a rear of the top wall **1814c**.

[0338] The moveable element **1850c** is generally almost semi-circular in shape although several other shapes are possible. In this particular embodiment, the moveable element **1850c** is not tethered to the cover **1812c**. The moveable element **1850c** has a peripheral edge that is annular. The moveable element **1850c** is further dimensioned wherein a portion of the peripheral edges engage inner faces of the channel

**1888c**. There is generally an interference fit between the moveable element **1850c** and the channel **1888c** that maintains the moveable element **1850c** connected to the channel **1888c** but allows for sliding movement. The channel **1888c** preferably contains retaining lips **1894c** at each edge to retain the moveable element **1850c** in the channel **1888c**, while allowing for sliding movement. It is understood that the moveable element **1850c** may be retained in the channel **1888c** by a myriad of different means, and the track **1842c** may take a different form than those described.

[0339] As shown in FIGS. **88** and **89**, the moveable element **1850c** is slideable within the track **1842c** and channel **1888c** between closed and open positions. FIG. **88** shows the lid **1810b** in a closed position wherein the moveable element **1850c** is slid forward wherein the moveable element **1850c** covers the opening **1828c**. In this position, the annular peripheral edge of the moveable element **1850c** generally coincides with the annular edge of the top wall **1814c**. FIG. **89** shows the lid **1810c** in an open position wherein the moveable element **1850c** is slid along the track **1842c** towards the rear of the cover **1812c** wherein the moveable element **1850c** is spaced from the opening **1828b**. The moveable element **1850c** is guided in the track **1842c** and the narrowing portion **1899c** of the channel **1888c** provides a stop for the moveable element **1850c**.

[0340] FIGS. **90-92** disclose another embodiment of the lid, generally designated with the reference numeral **1810d**. In this embodiment, the track **1842d** is located on or near an outer peripheral edge **1818d** of the cover **1812d**, even extending circumferentially around the edge **1818d** of the cover **1812d**.

[0341] As further shown in FIGS. **90-92**, the track **1842d** is annular and is defined in the cover **1812d** at the interface between the cover top wall **1814d** and the cover side wall **1816d**. In one preferred embodiment, the track **1842d** has a slot **1830d**. Although the slot **1830d** extends generally around a full circumference of the cover **1812d**, it is understood that the slot **1830d** could only extend a portion of the circumference proximate the opening **1828d**. Also, the slot **1830d** does not extend completely through the cover **1812d**, to avoid problems with spillage of the flowable substance through the slot **1830d**.

[0342] The moveable element **1850d** is generally a tab member having one portion that extends across the top wall **1814d** of the cover **1812d** and another portion that extends across the side wall **1816d** of the cover **1812d**. At an interface between the portions, the moveable element **1850d** has a mount **1851d** located on an inner surface of the moveable element **1850d**. The mount **1851d** is dimensioned to be received in the slot **1830d** of the cover **1812d**. The mount **1851d** is preferably received in the slot **1830d** in a snap-fit arrangement. As shown in FIG. **92**, this cooperative structure secures the moveable element **1850d** to the cover **1812d** while permitting the moveable element **1850d** to slide along the track **1842d** between the open position and the closed position. This mount **1851d** can comprise a lip, cusp, peg, or other protrusion that extends into the slot **1830d**. Thus, the important aspect is that the cooperative structure maintains a sliding connection between the moveable element **1850d** and the cover **1812d**. It is understood that the moveable element **1850d** can be retained to the cover **1812d** in a variety of different ways, and the track **1842d** could take one of many different forms. For example, cover **1812d** could contain retaining lips or other retaining structure on the top wall

**1814d** and side wall **1816d**, retaining the moveable element **1850d** to the cover **1812d**. In such case, the cooperative structure between the mount **1851d** and the slot **1830d** could be modified to primarily a guide structure rather than a retaining structure.

[0343] As shown in FIGS. 90-92, the moveable element **1850d** is slideable along the outer peripheral track **1842d** between closed and open positions. FIG. 91 shows the lid **1810d** in a closed position wherein the moveable element **1850d** is slid along the track **1842d** wherein the moveable element **1850d** covers the opening **1828d**. FIG. 90 shows the lid **1810d** in an open position wherein the moveable element **1850c** is slid along the track **1842d** to one side wherein the moveable element **1850d** is spaced from the opening **1828d**. The moveable element **1850d** is guided in the track **1842d** by the cooperative structure of the mount **1851d** and slot **1830d**. It is understood that the moveable element **1850d** can be slid on either side of the opening **1828d**.

[0344] FIGS. 93-95 disclose yet another variation of the lid, generally designated with the reference numeral **1810e**. As shown in FIG. 95, the cooperative structure in this embodiment is a track **1842e**, defining a slot **1830e** in the top wall **1814e**, that receives a mount **1851e** located on an underside surface of the moveable element **1850e**. The moveable member **1850e** is generally a flat, disk shaped member. The top wall **1814e** has a contoured edge **1847e** that a peripheral edge of the moveable element **1850e** engages between the open and closed positions. The contoured edge **1847e** may also include a retaining lip **1894e** (FIG. 95) that cooperates with another retaining lip **1895e** (FIG. 94) on the peripheral edge **1818e** of the top wall **1814e** to secure the moveable element **1850e** to the cover **1812e**. Although not shown in FIGS. 93-95, the retaining lip **1895e** may include a top overhang member if desired. FIG. 93 shows the lid **1810e** in a closed position wherein the moveable member **1850e** covers the opening **1828e**. FIG. 94 shows the lid **1810e** in an open position wherein the moveable member **1850** slides along the track **1842e** and is spaced from the opening **1828e**. It is understood that the slot **1830e** could be modified to secure the moveable element **1850e** to the cover **1812e** without the need for the retaining lips **1894e**, **1895e**. For example, the mount **1851e** and slot **1830e** structures could be modified to resemble the mount **1851d** and slot **1830d** structures shown in FIGS. 90-92.

[0345] Yet an additional embodiment of a lid assembly **1910** according to the present invention is disclosed in FIGS. 96-99. The lid assembly **1910** generally includes a lid or cover **1912** and a movable element **1950** operably associated therewith.

[0346] The cover **1912** includes a top wall **1950** having in one preferred embodiment, an annular top wall **1916** and a central portion **1918**. The central portion **1918** is generally recessed from the annular top wall **1916** and has a recessed area for receiving a lip of a user when drinking from the lid assembly **1910**. The cover **1912** further has a side wall **1919** depending from the annular top wall **1916** and having a mounting portion adapted for mounting the cover **1912** to a cup as previously described and as shown in FIG. 96. The recessed area further defines an inner sidewall **1923**. The annular top wall **1916** has an offset portion **1917** that defines a first stop **1920** and a second stop **1920**. An annular rail **1922** is defined in the offset portion **1917** and specifically between the stops **1920**. The annular rail **1922** may also include the portions of the side wall **1919** and the inner side wall **1923**

between the stops **1920**. The cover **1912** has a drink opening **1924** positioned in the annular top wall **1916** at the annular rail **1922**. The annular rail **1922** has a pair of grooves or channels **1926** located on the side wall **1919** and inner side wall **1923**. The channels **1926** are opposed to one another.

[0347] As further shown in FIGS. 96-99, the movable element **1950** includes a base **1928** and a skirt assembly **1929**. The skirt assembly **1929** comprises a pair of opposed depending walls **1930** depending from the base **1928**. A tab **1932** extends from the base **1928**. Protruding from an inner surface of each depending wall **1930** is a ridge **1934**. An underside of the base **1928** includes a slight bump **1935**. The bump **1935** is generally shaped similar to the drink opening **1924**.

[0348] To assemble the moveable element **1950** to the cover **1912**, the moveable element **1950** is positioned slightly above the annular rail **1922** such that the annular rail **1922** is generally received between the pair of depending walls **1930**. The moveable element **1950** is then pressed against the lid **1912** such that each ridge **1934** is received by a respective channel **1926**. There is some flexibility in the pair of depending walls **1930** to permit them to expand slightly to allow the ridges **1934** to be received by a respective channel **1926**.

[0349] In operation, the moveable element **1950** slides or moves along the annular rail **1922** between a first, closed position as shown in FIG. 98 to a second, open position as shown in FIG. 96. More specifically, each ridge **1934** slides along and within its respective channel **1926** between the open and closed positions. In the closed position shown in FIGS. 98 and 99, the base **1928** substantially seals or closes the drink opening **1924** and the bump **1935** is received by the drink opening **1924**. The bump **1935** and drink opening **1924** cooperate to act as a detent and provide the user with a tactile indication that the moveable element **1914** is in the closed position. Also, the bump **1935** and drink opening **1924** cooperate to maintain the moveable element **1950** in the closed position in the event of any vibration or unintended forces being exerted on the moveable element **1950** thereby tending to prevent any unintended spillage of the cup contents. As further shown, the movable element abuts one of the stops **1920**. In the second, or open position, the base **1928** is moved away from the drink opening **1924** to expose the drink opening **1924** to allow access to the cup contents. In the open position, the movable element **1950** abuts the other stop **1920**. To move the moveable element **1950** between open and closed positions, a user engages the tab **1932** with a finger or thumb to exert a force on the tab **1932** consistent with the direction of intended travel of the moveable element **1950**.

[0350] Additionally, the cooperation between the bump **1935** and the drink opening **1924** may also provide a tactile indication that the moveable element **1950** is in the closed position as well as the cooperation between the bump **1935** and the annular rail **1922** may also provide a tactile indication that the moveable element **1950** is in the open position. Frictional engagement between the bump **1935** and annular rail **1922**, as well as the movable element **1950** in general, may assist to retain the moveable element **1950** in the open position.

[0351] It is noted that the drink opening **1924** may alternatively have a slight bump and the underside of the base **1928** may have a slight recess to provide a similar, but reversed structure as shown in the figures.

[0352] As shown in FIGS. 96-99, the moveable element **1950** is movable generally to one side of the drink opening **1924**. It is understood that the annular rail **1922** could be



positioned about the drink opening 1924 such that the moveable element 1950 is movable to generally the opposite side as shown in the figures. It is further understood that the annular rail 1922 could extend to both sides of the drink opening 1924 wherein a user could move the moveable element 1950 to either side of the drink opening 1924 for the open position.

[0353] In one preferred embodiment, the lid 1912 is thermoformed and the movable element 1950 is an injected-molded part. It is understood, however, that the components of the lid assembly 1910 could be formed from a variety of known manufacturing processes.

[0354] Still other embodiments are contemplated, incorporating different combinations of the features described herein.

[0355] The lids of the present invention provide several benefits. The lid provides a means by which to allow a consumer to seal the contents of the beverage inside the container to prevent leakage, spillage, contamination, and heat loss or gain, while retaining the ability to quickly and easily reopen the container for beverage consumption. The lid of the present invention has a construction providing for simple and effective operation and is easy to assemble. The lid can be easily mass-produced and is disposable and recyclable.

[0356] The lids of the present invention can be manufactured using a variety of different processes, including thermoforming, vacuum forming, pressure forming, injection molding, blow molding, and any other suitable process. Additionally, separate components of the same lid can be made using different manufacturing processes. For example, the cover of a particular lid may be thermoformed, while the moveable element is injection molded.

[0357] Finally, several preferred embodiments of the lid of the present invention have been described herein. It is understood that the different features of the several different embodiments can be utilized in various combinations as desired.

[0358] The dimensions of the lids 10, 210, 310, 510, 610, 710, 810, 1010, 1110, 1210, 1310, 1410, 1510, 1610, 1710, 1810, 1910 can vary with design parameters. For example, the outer diameter of the aforementioned lids as measured from opposed points in the mounting portion can vary. As another example, the overall height of the lids as measured from the lower edge of the mounting portion to the top wall can vary. One of ordinary skill recognizes that the dimensions can be adjusted without departing from the spirit of the invention.

[0359] While specific embodiments have been illustrated and described, numerous modifications come to mind without significantly departing from the spirit of the invention and the scope of protection is only limited by the scope of the accompanying Claims.

What is claimed is:

1. A lid for a container holding a flowable substance, the lid comprising:

a cover adapted to be attached to the container, the cover having a top wall, a side wall having a mounting portion configured for connecting the lid to the container, and an opening, the cover having a track extending along a center of the cover; and

a moveable element slidably mounted on the track,

wherein the moveable element is moveable by sliding along the track between a first position wherein the moveable element obstructs the opening, and a second position wherein the moveable element does not obstruct the opening.

2. The lid of claim 1, wherein the moveable element further comprises a gripping element extending from the moveable element.

3. The lid of claim 1, wherein the moveable element further comprises a plug, wherein when the moveable element is in the first position, a portion of the plug is received in the opening.

4. The lid of claim 1, wherein the track extends along the top wall of the cover.

5. The lid of claim 4, wherein the track extends along a top surface of the top wall, and the moveable element is slidably mounted above the top surface of the top wall.

6. The lid of claim 1, wherein the track has a flat surface and the moveable element has a flat surface, and wherein the flat surface of the moveable element is positioned in confronting relation to the flat surface of the track and slides against the flat surface of the track.

7. The lid of claim 1, wherein the track comprises two elongated members, each elongated member engaging a portion of the moveable element to slidably mount the moveable element on the track.

8. The lid of claim 1, wherein the track comprises two elongated, parallel, linear grooves, and the moveable element is slidably mounted on the track such that portions of the moveable element are received in each of the two grooves.

9. The lid of claim 8, wherein the moveable element has two opposed, linear edges, and wherein each of the edges is received in one of the two grooves to slidably mount the moveable element on the track.

10. The lid of claim 8, wherein the track further comprises generally vertical portions adjacent each groove, the vertical portions and the grooves forming a channel, and wherein the moveable element is received in the channel.

11. The lid of claim 1, wherein the track comprises a channel formed on the top wall of the lid, and the moveable element is received in the channel to slidably mount the moveable element on the track.

12. The lid of claim 11, wherein the channel is located on a top surface of the top wall of the lid and is recessed from an uppermost point of the top surface.

13. The lid of claim 1, wherein the cover further has a lip recess proximate the opening.

14. The lid of claim 13, wherein the mounting portion is located below the lip recess.

15. The lid of claim 1, wherein the moveable element is elongated and has a length dimensioned such that the moveable element is positioned within an outer periphery of the top wall when the moveable element is in the first position and the second position.

16. The lid of claim 1, wherein moveable element and the track are elongated in a direction of sliding of the moveable element.

17. A lid for a container holding a flowable substance, the lid comprising:

a cover adapted to be attached to the container, the cover having a top wall, a side wall having a mounting portion configured for connecting the lid to the container, an opening, and a track thereon extending along the cover, the track comprising two parallel grooves; and

a moveable element slidably mounted on the track, wherein portions of the moveable element are received in each of the two grooves,

wherein the moveable element is moveable by sliding along the track between a first position wherein the

moveable element obstructs the opening, and a second position wherein the moveable element does not obstruct the opening.

18. The lid of claim 17, wherein the moveable element further comprises a gripping element extending from the moveable element.

19. The lid of claim 17, wherein the moveable element further comprises a plug, wherein when the moveable element is in the first position, a portion of the plug is received in the opening.

20. The lid of claim 17, wherein the track extends across a top surface of the top wall, and the moveable element is slidably mounted above the top surface of the top wall.

21. The lid of claim 17, wherein the track has a flat surface located between the two grooves and the moveable element has a flat surface, and wherein the flat surface of the moveable element is positioned in confronting relation to the flat surface of the track and slides against the flat surface of the track.

22. The lid of claim 17, wherein the moveable element has two opposed, linear edges, and wherein each of the edges is received in one of the two grooves to slidably mount the moveable element on the track.

23. The lid of claim 17, wherein the track further comprises generally vertical portions adjacent each groove, the vertical portions and the grooves forming a channel, and wherein the moveable element is received in the channel.

24. The lid of claim 23, wherein the channel is located on a top surface of the top wall of the lid and is recessed from an uppermost point of the top surface.

25. A thermoformed lid for a container holding a flowable substance, the lid comprising:

a cover adapted to be attached to the container, the cover having a top wall, a side wall having a mounting portion configured for connecting the lid to the container, an opening, and an elongated track thereon extending laterally across the top wall proximate a center of the cover, the track comprising two parallel, linear grooves and generally vertical portions adjacent each groove, the vertical portions and the grooves forming a channel; and an elongated moveable element slidably mounted on the track, the moveable element having two opposed, linear edges, wherein the moveable element is received in the channel and each of the edges is received in one of the two grooves to slidably mount the moveable element on the track, the moveable element further comprising a gripping element extending from the moveable element, wherein the moveable element is moveable by sliding along the track between a first position wherein the moveable element obstructs the opening, and a second position wherein the moveable element does not obstruct the opening.

26. The lid of claim 25, wherein the track extends across a top surface of the top wall, wherein the channel is recessed from an uppermost point of the top surface of the top wall, and wherein the moveable element is slidably mounted above the top surface of the top wall.

\* \* \* \* \*