

T. Singleton,

Warping Machine.

No. 110,795.

Patented Jan. 3. 1871.

Fig. 1.

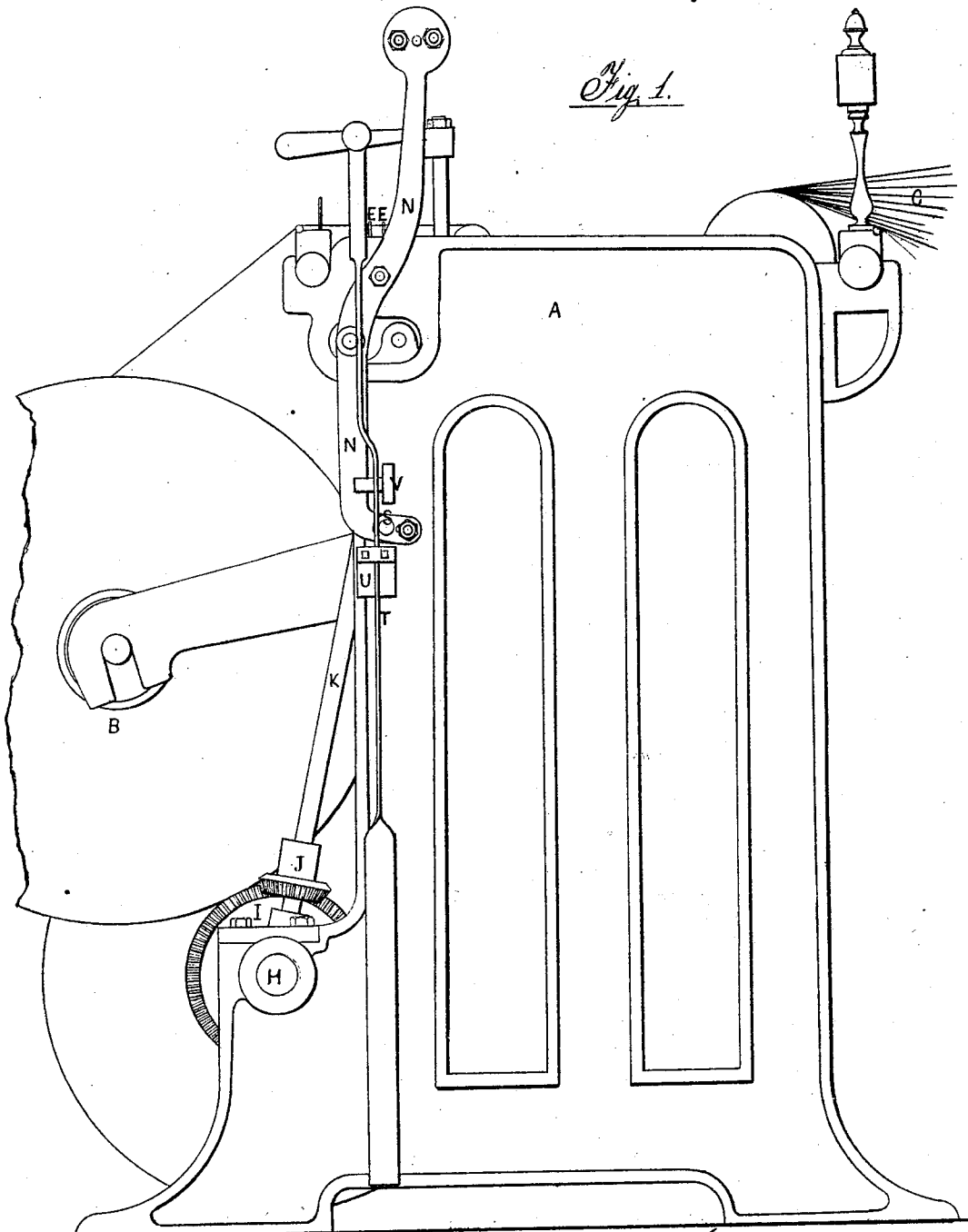

Witnesses.

Thomas Hogston
Oliver Wolcott Holme

Inventor.

Thomas Singleton

T. Singleton,

3, Sheets, Sheet 2.

Warping Machine.

No. 110,795.

Patented Jan. 3, 1871.

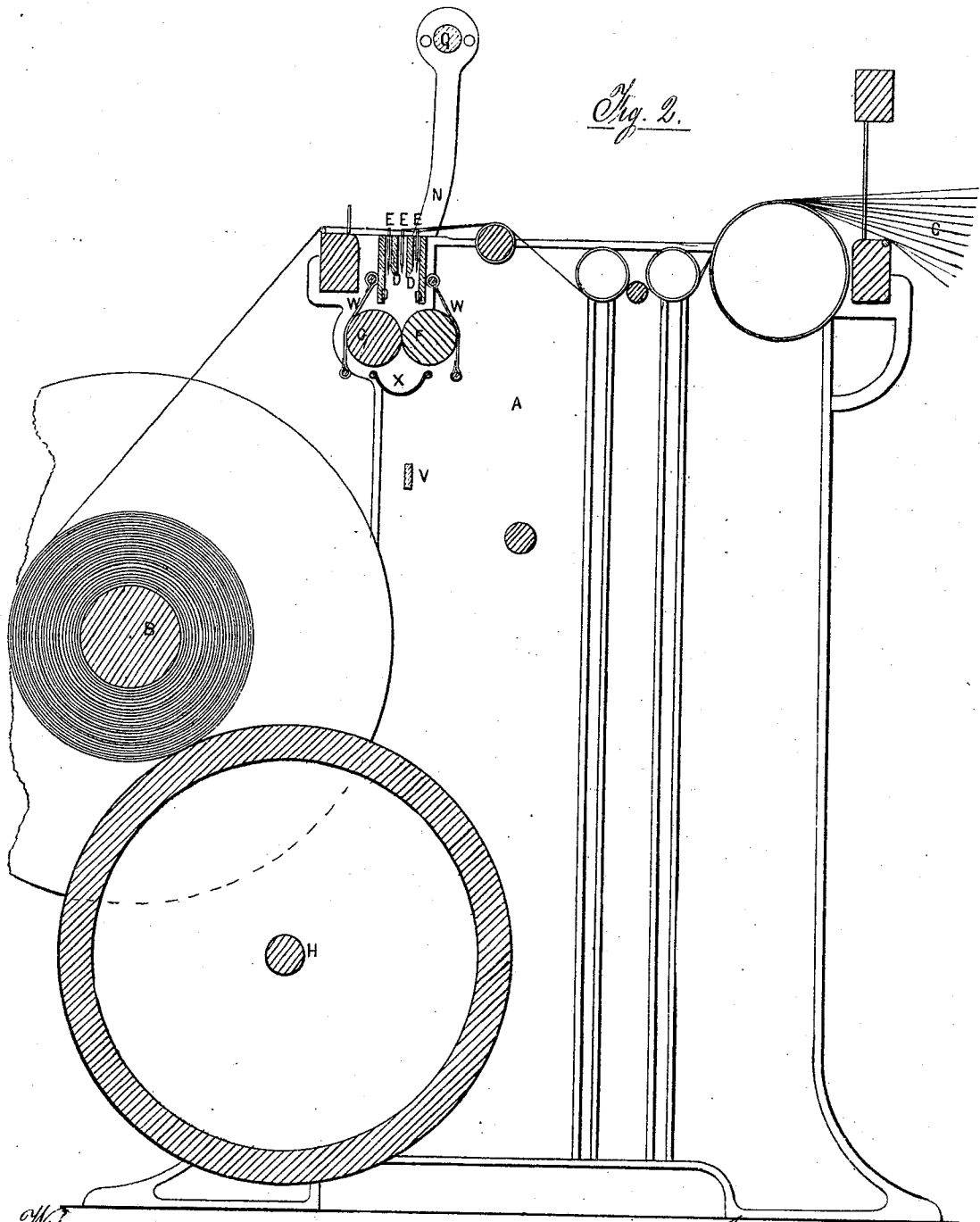

Witnesses

Thomas Houghton
Pearce & Co. Stockholm

Inventor
Thomas Singleton

T. Singleton,

Warping Machine.

No. 110,795.

Patented Jan. 3. 1871.

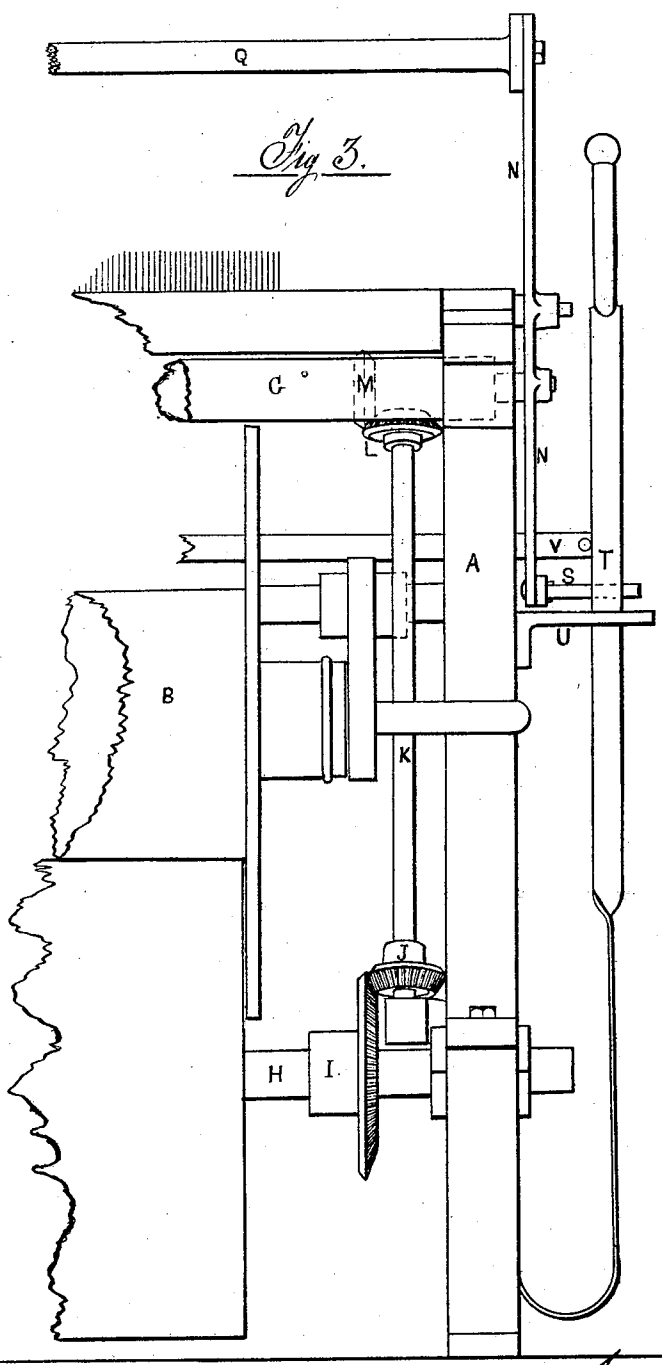

Witnesses

*Thomas Houghton
Pearce & Wolstenholme*

Inventor

Thomas Singleton

United States Patent Office.

THOMAS SINGLETON, OF OVER DARWEN, ENGLAND.

Letters Patent No. 110,795, dated January 3, 1871.

IMPROVEMENT IN WARPING-MACHINES.

The Schedule referred to in these Letters Patent and making part of the same.

I, THOMAS SINGLETON, of Over Darwen, in the county of Lancaster, England, have invented certain "Improvements in Warping-Machines," of which the following is a specification.

Nature and Objects of the Invention.

The nature of my invention consists in a self-acting stopping motion, and has for its object that of causing the machine to stop in case a thread of the warp breaks.

For this purpose I take an ordinary warping-machine and place near where the warp passes through the front comb, either in front or behind the said comb, two or more bars or plates of metal or other material placed edge upward and extending across the machine. These bars or plates may be attached together at the ends or rest separately in suitable bearings, the said bars and the spaces between them forming a sort of grid or grate, which, instead of being made in parts as here described, may be made in one piece.

The said grid or grate I place in such a position that the threads of the warp shall pass across the spaces in the grid and touch, or nearly so, the metal between the spaces.

Upon each thread of the warp I hang a small weight, by preference in the form of a staple, open at or near the bottom, for the convenience of putting it on the thread. These staples hang down in the spaces of the grid, the metal bars of which serve to keep them from moving forward or backward with the threads of the warp upon which they hang, at the same time the slots or spaces in the grid will allow them to move sidewise as the sheet of warp may be expanded or contracted in width.

Extending all along, and just below where these staples hang upon the threads of the warp, I have two rollers, either fluted or plain, revolving in contact, one only of which rollers need be driven by the machine, as the other roller, being free to turn, will revolve by contact with the driven roller.

One of the two rollers, which I will call the swing-roller, is suspended by two arms, and is capable of moving to and from the other roller. The said arms are either each attached to a shaft, so that one arm may not move without the other, or they may be attached to the grid, which, in that case, is made with a pivot at each end, so that it may turn slightly.

If a thread of the warp should break, the staple hung upon it at once falls down onto and is taken between the two rollers revolving below, thus separating them a short distance apart, and causing a pin or projection on one of the arms to push the ordinary

knocking-off spring from its detent, and so stop the machine.

The operative has a number of spare staples, and, after piecing the broken thread, drops one of them upon it to replace the one that has passed through the rollers. Those which pass through the rollers fall into a box below them, from which box they may be taken out occasionally.

Description of the Accompanying Drawing.

Figure 1 is an end elevation of a machine embodying my invention.

Figure 2 is a transverse section.

Figure 3 is a part of a front elevation.

Figures 4 and 5 are detached parts, showing the arms attached to the grid, and showing the pivots of the grid.

Figures 6 and 7 show the staples full size.

General Description.

A is the frame of the machine;

B, the beam upon which the warp is wound; and

C, the threads of the warp coming to the machine from the creel, and which, after passing under and over the various rollers, pass through the staples E E on their way to the beam.

D D D D are the bars of metal forming the grid.

F and G are the two rollers revolving in contact, F being the driven one, and receiving its motion from the driving-shaft H of the machine either by means of an arrangement of toothed gearing, as shown by the parts I J K L M, or by means of a pulley on the shaft H driving a pulley on the roller F by a strap.

G is the roller which revolves by contact with the roller F. It is supported by arms N, figs. 1, 2, 3, or by arms P, figs. 4 and 5.

The arms N are attached to the shaft Q, figs. 2 and 3, for the purpose of insuring them both moving at once.

Figs. 4 and 5 show the manner of attaching the arms to the grid in lieu of to the shaft Q, in which case the grid is made with a journal, R, to allow it to adapt itself to the motion of the arms.

S is an adjustable pin or projection upon one of the arms, and acts upon the knocking-off spring T, pressing it out of its detent in the bracket U, when, as is usual, the spring flies inward and carries with it the rod V, to which is attached the strap-fork, and which carries the strap onto the loose pulley, and the machine stops.

W W are pieces of flannel resting lightly on the two rollers, and serving to keep them clean.

X is the box into which the staples fall after passing through the rollers.

Claims.

I claim as my invention—

1. The two rollers F and G and the two arms N or P, and the journal R, in combination, substantially as and for the purpose hereinbefore set forth.
2. The falling weights or staples E E E, in com-

ination with the rollers F and G, to stop the machine, as hereinbefore described.

THOMAS SINGLETON.

Witnesses:

CHARLES DARLEY,
Solicitor, Blackburn.

THOMAS COLLISON,
Patent Agent, Blackburn.