

(No Model.)

J. WOODS.  
FARM GATE.

No. 525,674.

Patented Sept. 4, 1894.

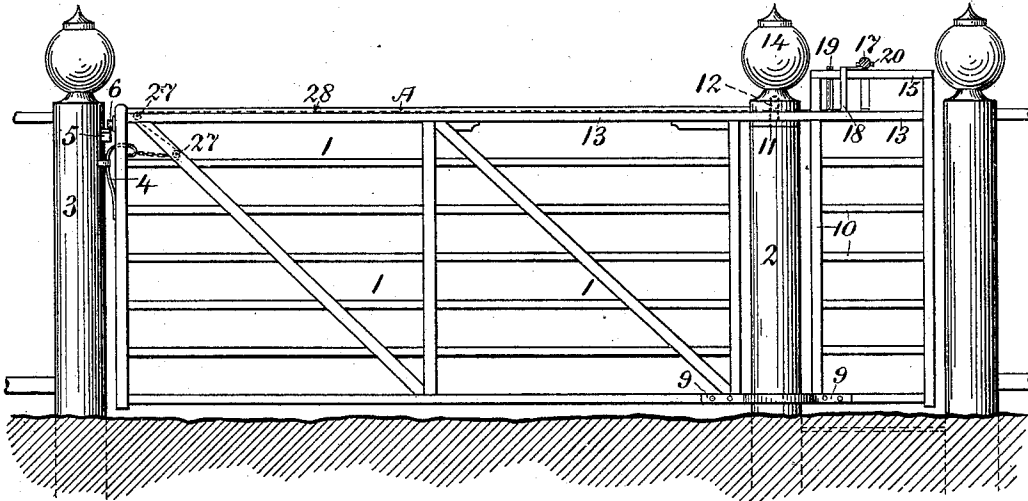

Fig. 1.

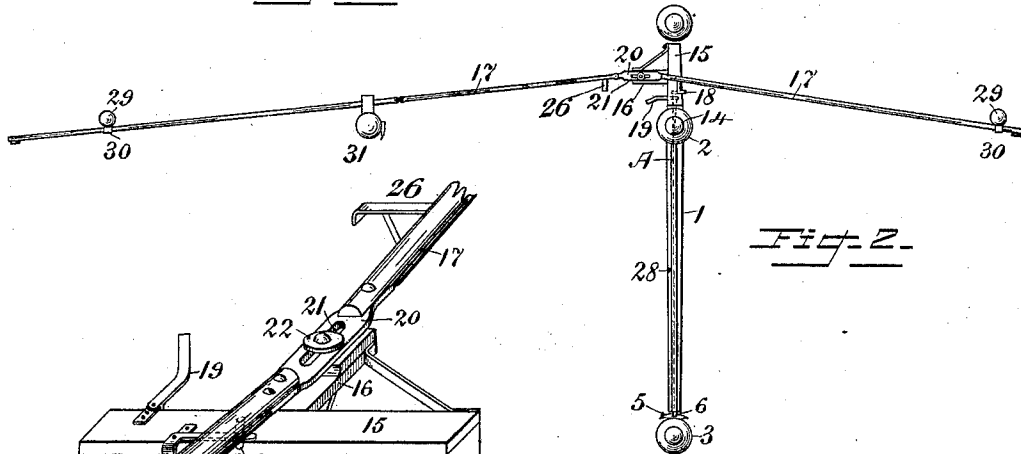

Fig. 2.

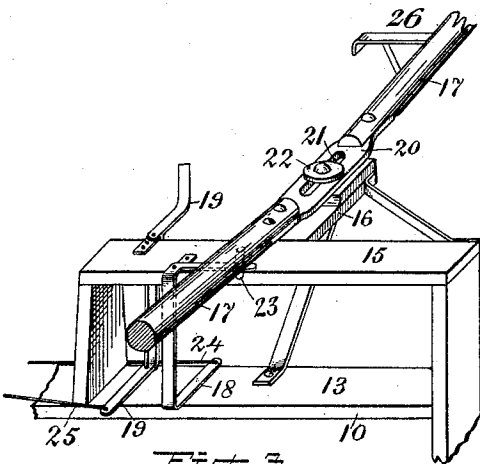

Fig. 3.

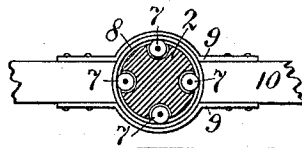

Fig. 4.

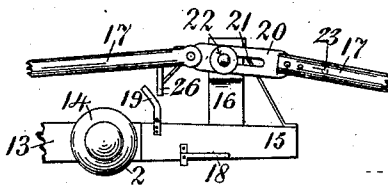

Fig. 5.

WITNESSES

*Harry Dixon*

*C. L. Lawrie*

INVENTOR

*James Woods*

*Per W. Graham*

*Atty.*

# UNITED STATES PATENT OFFICE.

JAMES WOODS, OF NEWTON BROOK, CANADA.

## FARM-GATE.

SPECIFICATION forming part of Letters Patent No. 525,674, dated September 4, 1894.

Application filed December 18, 1893. Serial No. 493,967. (No model.)

*To all whom it may concern:*

Be it known that I, JAMES WOODS, of Newton Brook, in the county of York and Province of Ontario, Canada, have invented a certain new and useful Farm-Gate, of which the following is a specification.

My invention relates particularly to that class of farm gates that can be opened by a rider or driver from a vehicle.

In the accompanying drawings illustrating my invention, in which similar numbers of reference refer to similar parts throughout—Figure 1, represents a side elevation of the gate having the operating rod in section, and showing the posts. Fig. 2, represents a reduced plan of the gate closed. Fig. 3, represents a perspective detail of the principal operating mechanism in opening and closing and latching and unlatching the gate in both positions. Fig. 4, represents a section of the hinge post at the lower hinge, and Fig. 5, represents a detail plan of a portion of the gate to more fully show the operation and construction.

The gate, 1, may be constructed of usual materials, and between the hinge and latch posts, 2, and 3, respectively, does not differ materially from other gates, the usual spring latch, 4, being employed preferably, and a rest piece 5, on the post, 3, on which an anti-friction roller, 6, on the gate, 1, bears when closed, and relieves the hinge post, 2, from the entire weight constantly, of the gate, 1.

The hinge post, 2, has at the bottom of the gate, 1, four anti-friction rollers, 7, disposed round its circumference and secured in adapted recesses in the post, 2, as shown in Fig. 4, which rollers, 7, are for the ring, 8, to bear on. The ring, 8, is preferably a metal ring and is clamped by two bars, 9, curved to fit on said ring, 8, and extending straight at their ends by which they are secured by ordinary bolts to the gate, 1, at the front, and to the partial counterweight, 10, in rear of said hinge post, 2. The upper end of the post, 2, terminates near the top of the gate, 1, and is capped by a metal disk, 11, secured thereon and having a center pin, 12, which projects through the top rail, 13, of the gate, 1, and into the head, 14, of said post, 2. The top rail, 13, extends in the rear of the post, 2, and supports the partial counter weight, 10,

and the operating mechanism hereinafter described.

The counter weight portion, 10, of the gate, 1, may be used to form a gate for pedestrians, or the fence may be extended and connected to the post, 2, on the back side of, and out of the way of the counter weight 10, when swinging.

On the top rail, 13, is supported a frame, 15, having a right-angled extension, 16, suitably braced and adapted to carry the operating bars, 17, and the cranked levers, 18, and 19, supported on opposite sides of the frame, 15, and contacted and operated by the operating bars, 17, to operate the spring latch, 4, first and finally to act on the counter weight portion, 10, of the gate, 1, in opening and closing the same.

The operating bars, 17, are secured to opposite ends of the plate, 20, (one of them being jointed thereto as shown.) In the plate, 20, a slot, 21, is provided through which is passed a bolt, 22, to connect said plate, 20, loosely to the extension, 16, of the gate, 1, allowing the plate, 20, to reciprocate some distance without moving the gate, 1. One of these operating bars, 17, has a pin, 23, projecting beneath it to engage with the cranked lever, 18, (on the same side of the frame, 15,) for the purpose of operating said lever, 18, to draw the rod, 24, and operate the latch, 4, in opening the gate, 1. On the other operating bar, 17, is a bracket, 26, adapted to engage with the cranked-lever, 19, and by the medium of the rod, 25, operate said latch, 4, when closing the gate, 1.

The rods, 24, and 25, unite and are connected to a chain, A, which extends along the top rail, 13, and over rollers, 27 to the latch, 4, and is covered by a grooved strip, 28, within which the chain A, is protected from ice, snow, and damage.

The bars, 17, extend on opposite sides of the gate, 1, normally or when closed, and are supported on posts, 29, but at one side of the gate, 1, the corresponding bar 17 extends the width of the gate, 1, farther, to provide for its opening to that side. The posts, 29, have an eye, 30, on each to carry the bars, 17.

On the opposite side of the road from the latch post, 3, and the width of the gate, 1, from the post, 2, is an open latch post, 31, to

which the gate, 1, opens and latches similarly as it latches when closed to the post, 2.

When the gate is being opened one of the operating bars, 17 is pushed or pulled according to the side approached from and the following action takes place: The pin, 23, or the bracket, 26, on the operating bars, 17, operates one of the cranked levers 18, or 19 to draw back the latch, 4, then the bolt, 22, in the plate, 20, is engaged and carries the gate, 1, open. In closing the gate, 1, one of the bars, 17, is operated reversely to the direction of opening; the alternative cranked lever 18 or 19 is operated to draw the latch, 4, and disengage it from the latch post, 31, next the gate, 1, swings closed and by the momentum thereof it latches on the latch post, 3, again.

Having described my invention, what I

claim, and desire to secure by Letters Patent, is—

In combination, the gate having a counter weighted portion as specified, the hinge post having anti-friction rollers and a center pin to support the bottom and top rails, respectively, of the gate, a latch spring at the front, levers on the counter-weighted portion as specified, means to connect said latch with said levers, and the operating bars connected to a slotted plate between them and one having a pin and the other a bracket to engage said levers, substantially as specified.

JAMES WOODS.

In presence of—

MUNRO INNES,

ALEX. D. CARTWRIGHT.