



## INTERNATIONAL APPLICATION PUBLISHED UNDER THE PATENT COOPERATION TREATY (PCT)

<p>(51) International Patent Classification <sup>6</sup> : <b>F28G 15/04, B08B 9/04, B65H 75/44</b></p>	<p><b>A1</b></p>	<p>(11) International Publication Number: <b>WO 00/17595</b></p> <p>(43) International Publication Date: 30 March 2000 (30.03.00)</p>
<p>(21) International Application Number: PCT/IT98/00253</p> <p>(22) International Filing Date: 23 September 1998 (23.09.98)</p> <p>(71) Applicant (for all designated States except US): IDROJET S.A.S. [IT/IT]; Via Luigi Pirandello, I-95040 Piano Tavola (IT).</p> <p>(72) Inventor; and (75) Inventor/Applicant (for US only): LA FERLA, Danilo [IT/IT]; Via Alcide de Gasperi, 177, I-95127 Catania (IT).</p> <p>(74) Agents: LEONE, Mario et al.; Società Italiana Brevetti S.p.A., Piazza di Pietra, 39, I-00186 Roma (IT).</p>		<p>(81) Designated States: AL, AM, AT, AU, AZ, BA, BB, BG, BR, BY, CA, CH, CN, CU, CZ, DE, DK, EE, ES, FI, GB, GD, GE, GH, GM, HR, HU, ID, IL, IS, JP, KE, KG, KP, KR, KZ, LC, LK, LR, LS, LT, LU, LV, MD, MG, MK, MN, MW, MX, NO, NZ, PL, PT, RO, RU, SD, SE, SG, SI, SK, SL, TJ, TM, TR, TT, UA, UG, US, UZ, VN, YU, ZW, ARIPO patent (GH, GM, KE, LS, MW, SD, SZ, UG, ZW), Eurasian patent (AM, AZ, BY, KG, KZ, MD, RU, TJ, TM), European patent (AT, BE, CH, CY, DE, DK, ES, FI, FR, GB, GR, IE, IT, LU, MC, NL, PT, SE), OAPI patent (BF, BJ, CF, CG, CI, CM, GA, GN, GW, ML, MR, NE, SN, TD, TG).</p> <p><b>Published</b> With international search report. In English translation (filed in Italian).</p>

(54) Title: CLEANING DEVICE

(57) Abstract

A cleaning device (1) of the type operating by means of a pair of hydraulic nozzles (2), each nozzle spraying a cleaning liquid jet which carries out a swabbing action, allowing a considerable handling flexibility by making the nozzles (2) substantially independent from each other, and comprising an operative end (3) for handling said hydraulic nozzles (2); and a feeding unit (4) operating said hydraulic nozzles (2) by unwinding and winding a pair of hoses (5), each tube being connected to the respective hydraulic nozzle (2), comprising a reel (21), wherein said hoses (5) are wound; one or more motor-driven rotating elements (23) for moving said hoses (5) forward and backward; a drive shaft (30) controlled by a reversible

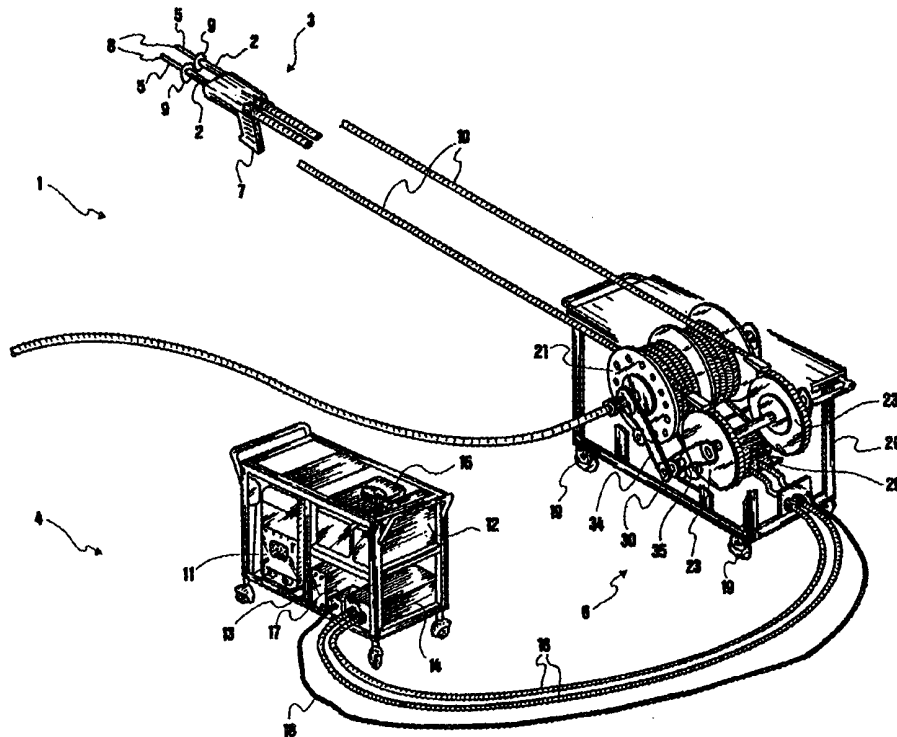

mover (29), mechanically connected both to the reel (21) and the rotating elements, so as to provide them with the same direction of rotation, said reel (21) being connected to said drive shaft (30) by a first power chain (31, 32, 34, 36) which operates when the hoses (5) are moved backward, with said rotating elements being independently connected from each other to said drive shaft (30) by respective second power chains (31, 33, 35, 37) which operates when said hoses (5) are moved forward.

**FOR THE PURPOSES OF INFORMATION ONLY**

Codes used to identify States party to the PCT on the front pages of pamphlets publishing international applications under the PCT.

AL	Albania	ES	Spain	LS	Lesotho	SI	Slovenia
AM	Armenia	FI	Finland	LT	Lithuania	SK	Slovakia
AT	Austria	FR	France	LU	Luxembourg	SN	Senegal
AU	Australia	GA	Gabon	LV	Latvia	SZ	Swaziland
AZ	Azerbaijan	GB	United Kingdom	MC	Monaco	TD	Chad
BA	Bosnia and Herzegovina	GE	Georgia	MD	Republic of Moldova	TG	Togo
BB	Barbados	GH	Ghana	MG	Madagascar	TJ	Tajikistan
BE	Belgium	GN	Guinea	MK	The former Yugoslav Republic of Macedonia	TM	Turkmenistan
BF	Burkina Faso	GR	Greece			TR	Turkey
BG	Bulgaria	HU	Hungary	ML	Mali	TT	Trinidad and Tobago
BJ	Benin	IE	Ireland	MN	Mongolia	UA	Ukraine
BR	Brazil	IL	Israel	MR	Mauritania	UG	Uganda
BY	Belarus	IS	Iceland	MW	Malawi	US	United States of America
CA	Canada	IT	Italy	MX	Mexico	UZ	Uzbekistan
CF	Central African Republic	JP	Japan	NE	Niger	VN	Viet Nam
CG	Congo	KE	Kenya	NL	Netherlands	YU	Yugoslavia
CH	Switzerland	KG	Kyrgyzstan	NO	Norway	ZW	Zimbabwe
CI	Côte d'Ivoire	KP	Democratic People's Republic of Korea	NZ	New Zealand		
CM	Cameroon			PL	Poland		
CN	China	KR	Republic of Korea	PT	Portugal		
CU	Cuba	KZ	Kazakstan	RO	Romania		
CZ	Czech Republic	LC	Saint Lucia	RU	Russian Federation		
DE	Germany	LI	Liechtenstein	SD	Sudan		
DK	Denmark	LK	Sri Lanka	SE	Sweden		
EE	Estonia	LR	Liberia	SG	Singapore		

**“CLEANING DEVICE”****DESCRIPTION**

The present invention relates to a cleaning device, in particular for tube bundles and the like, comprising a pair of hydraulic nozzles which carry out a swabbing action by spraying a cleaning liquid.

In its general-purpose embodiment, such device comprises an operative end for handling said nozzles, and a feeding unit moving said nozzles by winding and unwinding a pair of hoses, each connected to its respective hydraulic nozzle, said feeding unit comprising a reel wherein the hoses are wound, and one or more motor-driven rotating elements, which are apt to drag forward and backward said hoses.

As it is known, devices of the above-mentioned type are used especially in petrochemical plants, refineries and thermal power plants during maintenance operations for cleaning of heat exchange tube frames, eliminating the need to disassemble said frames.

In this kinds of applications, whose object is to remove said frames fouling which limits the effectiveness of the heat exchange, time is a crucial factor, as protracted maintenance extends downtime of said complex plants, resulting in money loss.

Present techniques provide manual operation of the hydraulic nozzles, possibly with the help of motor-driven mechanisms for winding and unwinding the hoses feeding the hydraulic nozzles, followed by manual finishing. A mechanism of this kind is described in European Patent No. 0,446,653 B1 in the name of MIGEN S.r.l.

Such techniques are slow, and imply the presence of at least two people carrying out a particularly heavy work.

Further devices are known, which provide mechanical operation of the pair of nozzles, wherein the control of the forward and backward motion is carried out by a single drive unit that acts on the nozzles only, i.e. on the rotating elements which are intended to move the hoses forward, feeding the nozzles

Said devices, even if they speed up the cleaning operations, involve reliability problems as, in cases when progress of one of the nozzles is stopped, for example because of particularly hard fouling, the other nozzle

stops as well.

Other systems comprise winches provided with helicoidal grooves or similar thrusting means for unwinding hoses from a reel, or smooth drums having roller assemblies that force the tubes against the cylindrical surface of the reel. These systems, like the ones mentioned above, provided with pneumatic drives, involve great problems with the nozzle synchronization.

Moreover, they are not particularly suitable for multiple nozzle operation.

The technical problem which underlies the present invention is to provide a cleaning device for overcoming the drawbacks mentioned with reference to the prior art.

Said problem is solved by a cleaning device, as set forth above, characterized in that said feeding unit comprises at least one drive shaft operated by a reversible mover, mechanically connected both to the reel and the rotating elements so as to provide them with the same direction of rotation, said reel being directly connected to said drive shaft by means of a first power chain which operates when the hoses are moved backward, and said rotating elements being independently connected from each other to said drive shaft by means of respective second power chains which operate when said hoses are moved forward.

The main advantage of the cleaning device according to the present invention is that it allows the nozzles to be moved forward independently from each other, so that while one of them is applied in the removal of hard fouling, the other is moved forward inside the tube bundle carrying out its own cleaning actions.

Furthermore, the reliability of the device is increased, while operating time is reduced, as no nozzle suffers an inactivity period during cleaning operations.

The present invention will be hereinafter disclosed by a preferred embodiment thereof, shown as a non-limiting example, with reference to the annexed drawings wherein:

\* figure 1 is a perspective view of the cleaning device according to the present invention;

\* figure 2 is a more detailed perspective view of the cleaning device of figure 1;

- 3 -

- \* figure 3 is an elevational side view of a detail of the cleaning device of figure 1;
- \* figure 4 is a side cross section view, along line A-A of figure 3, of the detail illustrated in said figure;
- 5 \* figure 5 is an elevational side view of a further detail of the cleaning device of figure 1; and
- \* figure 6 is a side cross section view, along line B-B of figure 5, of the detail shown in said figure.

10 With reference to figure 1, the cleaning device is indicated 1 as a whole. It is of the type normally used in petrochemical plants, refineries, thermal power plants and similar plants during maintenance operations for cleaning heat exchange tube frames, eliminating the need to disassemble said frames.

To this purpose, the device 1 comprises a pair of hydraulic nozzles 2 to be inserted inside the tubes, which spray a cleaning liquid jet, for example high-  
15 pressure water, carrying out a swabbing action inside the tubes.

The device 1 illustrated hereby generally consists of three components: an operative end 3, held by an operator to handle said hydraulic nozzles 2; a feeding unit 4, moving said hydraulic nozzles 2 by winding and unwinding a  
20 pair of hoses 5, each tube being connected to the respective hydraulic nozzle 2; and a power unit 6, which provides the feeding unit 4 and the nozzles 2 with the required power as it will be explained herebelow, for the forward and the backward motion of the nozzles 2.

In the present embodiment, pressurized water is provided by a feeding pipeline C, directly connected to the feeding unit 4.

25 The end 3 (figure 1) comprises a pistol-grip 7 supporting the pair of nozzles 2, which is used to position the latter in front of the inlet of the tube frame or bundle to be swabbed.

The pistol-grip 7 comprises switches to control the forward and the backward motion of the nozzles 2, together with the injection and the shutdown of the  
30 water flow.

Moreover, said pistol-grip 7 comprises a pitch adjuster of the usual type and hence not shown in figure 1, able to adjust the distance between the axes of the two nozzles to the pitch of the tubes to be swabbed.

- 4 -

Each nozzle 2 comprises a spraying outlet 8 and a protective element 9, protecting the operator from high-pressure liquid spray, which can be placed on the respective inlet of the tube to be cleaned.

5 The outlet 8 can be of the multiple-jet type, i.e. able to spray various jets whose directions originating from the outlet or head 8, to increase the swabbing action of said nozzle 2.

10 The end 3 is connected to the feeding unit 4 by means of a pair of flexible safety pipes 10, for example of the corrugated-surface type, inside which are housed the respective hoses 5, which feed the nozzles 2 with the water to be sprayed.

The main function of the flexible pipes 10 is the protection of said hoses 5, whose diameter is large enough to allow the hoses 5 to slide freely.

The power unit 6 (figure 1) comprises a first engine 11, which is the primary source of mechanic and hydraulic power of the device 1.

15 Said engine 11 can be for example of the silenced Diesel type, fed from a respective fuel, i.e. naphtha, tank 12, controlled by a suitable control board 13. Moreover, the engine 11 comprises a battery, not shown, for both the start up and the supply of the control board 13.

20 Furthermore, the power unit 6 comprises a first high-pressure hydraulic pump, driven by the engine axle and therefore not shown, for an oil circuit which, as will be explained herebelow, supplies hydraulic energy needed for moving the hoses 5 and the nozzles 2 forward and backward. Said pump is fed by a second tank 15 for the oil.

25 Pressurized oil is forwarded and brought back into the pump by a group of valves 14 and through respective first supply and return tubes, connecting the power unit 6 to the feeding unit 4.

The power unit 6 comprises also a terminal board 17, connecting it to the feeding unit 4 by way of a suitable electrical connection 18.

30 The feeding unit 4 (figure 1 and 2), mounted on wheels 19, comprises a frame 20 having a substantially parallelepipedal shape, wherein its components are installed.

The unit 4 comprises a reel 21, consisting of two separate spools indicated 21a and 21b, wherein hoses 5 are wound.

- 5 -

The reel 21 is installed on a first driven shaft 22, installed on the frame 20. Furthermore, the reel 21 horizontal axis of rotation is adjacent to one of unit 4 end side, i.e. the one wherefrom protective pipes 10 branch out, with the hoses 5 which are wound so as to unwind from the bottom of the reel 21, proceeding toward the center of the unit 4.

The reel 21 comprises, at its driven shaft 22 (figure 4), a rotating fluid joint 43 for the connection with the feeding pipeline C, which supplies high-pressure liquid, i.e. water in this example, to the wound hoses. To this purpose the joint 43 is provided with a threaded hub 44.

Such joint must withstand a 100 MPa pressure.

The unit 4, moreover, comprises a pair of rotating elements which, in the illustrated embodiment, comprise respective pulleys, each indicated 23, receiving in corresponding races 24 the hoses 5 from the reel 21. In order to guarantee the input of the hoses 5 into the corresponding race 24, the bottom of the pulley 23 comprises a leading element 45.

The pulleys 23 are mounted inside the frame 20 by means of a second horizontal driven axle 25, parallel to the axle of the reel 21 and installed substantially at the same level.

The hoses 5 are wound on the respective pulleys 23 with a circular arc of approximately  $190^\circ$ , and in any case wider than  $180^\circ$ . At the upper apex of the pulleys 23, the hoses 5 come out of the respective races 24 and are introduced into the respective protective pipes 10, which connect them to the respective hydraulic nozzles 2, as previously illustrated.

At said pulleys 23 (figures 5 and 6), the unit 4 comprises means to keep the hoses 5 adhered to the respective races 24.

Said means comprises, for each pulley, a plurality of chained rollers 26, which extend from the leading element to the upper apex of the pulleys 23.

In this preferred embodiment, the chained rollers 26 comprise an idle roller triple chain 27, extending on a circular arc of at least  $180^\circ$ , in order to keep the hoses 5 pressed and adhered to the races 24 because the high-pressure liquid flowing inside hoses 5 tends to keep them straighten.

This straightening force tends to eliminate the contact between the hoses 5 and the races 24, preventing pulleys 23 from dragging said hoses 5, as will be explained in detail herebelow.

- 6 -

Moreover, the unit 4 comprises (figures 5 and 6) first tightening means for keeping the triple chain 27, i.e. the rollers 26, pressed to the respective hose 5. Said tightening means comprises a dynamometer system 28 for exerting a variable adhering pressure against hoses 5, which will conveniently increase as internal pressure in hoses 5 increases.

The feeding unit 4 comprises moreover a reversible mover 29, fed by the driving fluid supplied by power unit 6.

Said mover 29 is a reversible hydraulic motor, i.e. capable of reversing its direction of rotation by simply changing the path followed by the driving fluid inside said motor.

Adjustment of motion induced by unit 4 is this way made easy, and can be controlled directly from operative end 3.

The hydraulic motor 29 rotates, in both possible directions, a drive shaft 30 of the feeding unit 4, provided with first gear wheels 31 for transmitting the motion produced by the shaft 30.

The driven axles 22, 25 of the reel 21 and of the pulleys 23 have, in their turn, respective second and third gear wheels 32 and 34 for to receive the motion produced by the drive shaft 30.

The drive shaft 30 is mechanically connected to control the rotation of the reel 21 and of the pulleys 23, so as to provide them with the same direction of rotation: the hoses 5, dragged by the pulleys 23, move forward when the reel 21 is operated to unwind, while, when the reel 21 is operated to wind, the hoses 5 are dragged backward.

To this purpose, the reel 21 is connected to the drive shaft 30 by a first power chain comprising, besides the relative first and second gear wheels 31 and 32, a first element for the transmission of motion 34, i.e. a chain in the present embodiment.

Similarly, each pulley 23 is connected to the drive shaft 30 by a second power chain, comprising a second element for the transmission of motion 35, i.e. a chain in the present embodiment.

Said first and second power chains further comprise respective first and second freewheel couplings 36 and 37, mounted on the respective driven shafts 22 and 25, which allow rotation of the reel 21 and of the pulleys 23.

- 7 -

In particular, the free-wheel coupling 36 and 37 are unidirectionally driving couplings provided with a driving element which drives a driven element only when it rotates in a predetermined direction, while it automatically disengaging when the driving element rotates in the opposite direction.

5 In the device 1 of the present invention, the free-wheel couplings 36 and 37 are placed so that the first power chain, i.e. the one connecting the drive shaft 30 and the reel 21, operates only when the hoses 5 are dragged backward, i.e. when the hoses 5 are wound on the reel 21.

10 Furthermore, the second power chain, i.e. the one connecting the drive shaft 30 and the pulleys 23, operates only when hoses 5 are moved forward, i.e. when the hoses 5 are pulled and pushed by the operation of the pulleys 23, in cooperation with the means for keeping hoses 5 adhering to the races 24.

15 In other words, thanks to the action second power chain, the drive shaft 30 transmits the motion to the pulleys 23, which make the hoses 5, and therefore the hydraulic nozzles 2 of the operative end 3, move forward, as the reel 21, which is free to rotate following to the direction of the pulleys 23, unwinds.

20 The driving action of the pulleys 23, i.e. of the corresponding rotating elements such as drums and similar, is therefore allowed, causing the hoses 5 to be dragged.

It is to be noted that each pulley 23 comprises its own second free-wheel coupling 37, so that they are connected to the drive shaft 30 independently from each other.

25 Moreover, thanks to the second power chain, the drive shaft 30 transmits the motion to the reel 21, which carries out a driving action, winding and unwinding the hoses 5.

30 The continuity of the motion transmission along the first and second power chains is assured by respective second and third tightening means, 38 and 39, connected to the frame 20 and partly shown (figure 2), which are connected to respective first and second auxiliary gear wheels, 40 and 41, which, supported by bars 42 hinged to frame 20, are pressed against motion transmitting chains 34 and 35.

The feeding unit 4 further comprises a limit stop 46 (figure 3), to prevent the pulleys from thrusting when the reel 21 has completed unwinding or winding

of hoses 5 .

Said stop 46 comprises a threaded spindle 47 caused to rotate by the reel 21 by means of a suitable gear-down device, comprising a chain 50 and a further gear wheel 51, both connected to the first driven axle 22, and suitable  
5 down gears 52, moving a mated follower 48, running along the whole spindle length: in one direction during unwinding, and in the opposite direction during winding.

The spindle ends are equipped with limit switches 49, contacted by the mated follower 48, so as to stop the hydraulic motor 29.

10 The hydraulic motor 29 is stopped also when the nozzles 2, or one of the nozzles 2, meet excessive resistance. This stop is regulated by a hydraulic oil maximum allowable pressure, monitored by a special sensor connected to the control board, not shown in the figure.

As for the operation of the device 1, the operator inserts the nozzles 2 in the  
15 respective tubes, and controls from the operative end 3 as the hoses 5 start unwinding and progress through the protective pipes 10, pushing the hydraulic nozzles 2 forward. In order to better protect the operator from sudden pressure surges, which could cause the hoses to dart like whips, the protective pipes 10 are stiffen by an internal steel braided wire.

20 At the same time, the pressurized water flow is let in, allowing it to defouling the tube internal surfaces.

As the hoses 5 move forward, the second free-wheel coupling 37 causes the pulleys 23, rotated by hydraulic motor 29 by means of the drive shaft 30 and the second power chain 31,33,35,37, to drag the hoses 5.

25 The adherence between the hoses 5 and the races 24 is assured by the above described means, which prevent the hoses 5 from slipping off, thus making the swabbing action ineffective.

When fouling is so hard as to slow down the forward motion of one of the  
30 nozzles 2, paired motion of the nozzles can be reinstated by reversing the rotation of the reel 21, i.e. making it drive and drag the hoses 5, so that the pulley 23 relative to the slowed-down nozzle 2, under the pulling action of the reel 21, will be able to rotate more quickly than the other pulley, pulleys 23 being free to rotate on their free-wheel couplings 37 and being no longer connected to the second driven shaft 25.

- 9 -

Any skewness of the nozzles 2 can therefore be corrected by a suitable winding, even minimum, by reversing the motion, an operation which can be easily carried out by a single operator from operative end 3.

5 A series of "forward and backward" operations can therefore rid the tube of the hardest fouling. In case the elimination of the latter should prove impossible, this would anyway cause nozzle 2 to stop, so that the operator would not need to stop the device 1 manually.

10 Besides the above mentioned advantage, the cleaning device described above with reference to its preferred embodiment allows significant reduction in the number of manual operations, with consequent reduction in the number of working accidents.

15 In order to meet further contingencies, a man skilled in the art will be able to provide the cleaning device described above with further different modifications, all of them, however, falling within the protective scope of the present invention, as defined by claims annexed hereinafter.

- 10 -

**CLAIMS**

1. A cleaning device (1) of the type operating by means of a pair of hydraulic nozzles (2), each nozzle spraying a jet of cleaning liquid which carries out a swabbing action, comprising an operative end (3) for handling said hydraulic nozzles (2); and a feeding unit (4), operating said hydraulic nozzles (2) by winding and unwinding a pair of hoses (5), each hose being connected to a respective hydraulic nozzle (2), said feeding unit (4) comprising a reel (21) wherein said hoses (5) are wound, and one or more motor-driven rotating elements (23), which are apt to drag forward and backward said hoses (5), characterized in that said feeding unit (4) comprises at least one drive shaft (30), controlled by a reversible mover (29) mechanically connected both to the reel (21) and the rotating elements (23) so as to provide them with the same direction of rotation, said reel (21) being directly connected to said drive shaft (29) by means of a first power chain (31, 32, 34, 36), which operates when said hoses (5) are moved backward, and said rotating elements (23) being independently connected from each other to said drive shaft (30) by respective second power chains (31, 33, 35, 37), which operate when said hoses (5) are moved forward.
2. The cleaning device, according to claim 1, wherein said first power chain comprises a first element (34) for the transmission of motion, connected to a respective first freewheel coupling (36) placed so as to transmit motion to the reel (21) when the hoses (5) are moved backward, allowing the reel (21) driving action to unwind the hoses (5).
3. The cleaning device (1), according to claim 1, wherein said second power chain comprises a second element (35) for the transmission of motion, connected to a respective second free-wheel coupling (37) placed so as to transmit motion to the respective rotating element (23) when the hoses (5) are moved forward, allowing the rotating element driving action to drag the hoses (5).
4. The cleaning device (1), according to claim 2, wherein said first element (34) for the transmission of motion is a chain.
5. The cleaning device (1) according to claim 3, wherein said second element (35) for transmission of motion is a chain.
6. The cleaning device (1) according to claim 1, wherein said one or more motor-driven rotating elements comprise a pair of pulleys (23), each of them

being apt to drag a corresponding hose (5) inserted in a respective race (24) of the pulley (23).

5       **7.** The cleaning device (1) according to claim 6, wherein the feeding unit (4) comprises means (26, 27) to keep the hoses (5) adhering their respective race (24).

**8.** The cleaning device (1) according to claim 7, wherein said means to keep the hoses (5) adhering comprise a plurality of rollers (26) chained therebetween and kept adhered to the respective hose (5) by tightening means (28).

10       **9.** The cleaning device (1) according to claim 8, wherein said plurality of chained rollers (26) is an idle roller triple chain (27).

**10.** The cleaning device (1) according to claim 8, wherein the chained rollers (26) extend on a circular arc of at least 180° on the respective pulley (23).

15       **11.** The cleaning device (1) according to claim 8, wherein said tightening means comprise a dynamometer system (28).

**12.** The cleaning device (1), according to claim 8, wherein adhering pressure exerted by the tightening means (28) increases as the hose (5) internal pressure increases.

20       **13.** The cleaning device (1) according to claim 1, where said reversible mover comprises a hydraulic motor (29) to which power is supplied by means of a pressurized driving liquid from a power unit (6).

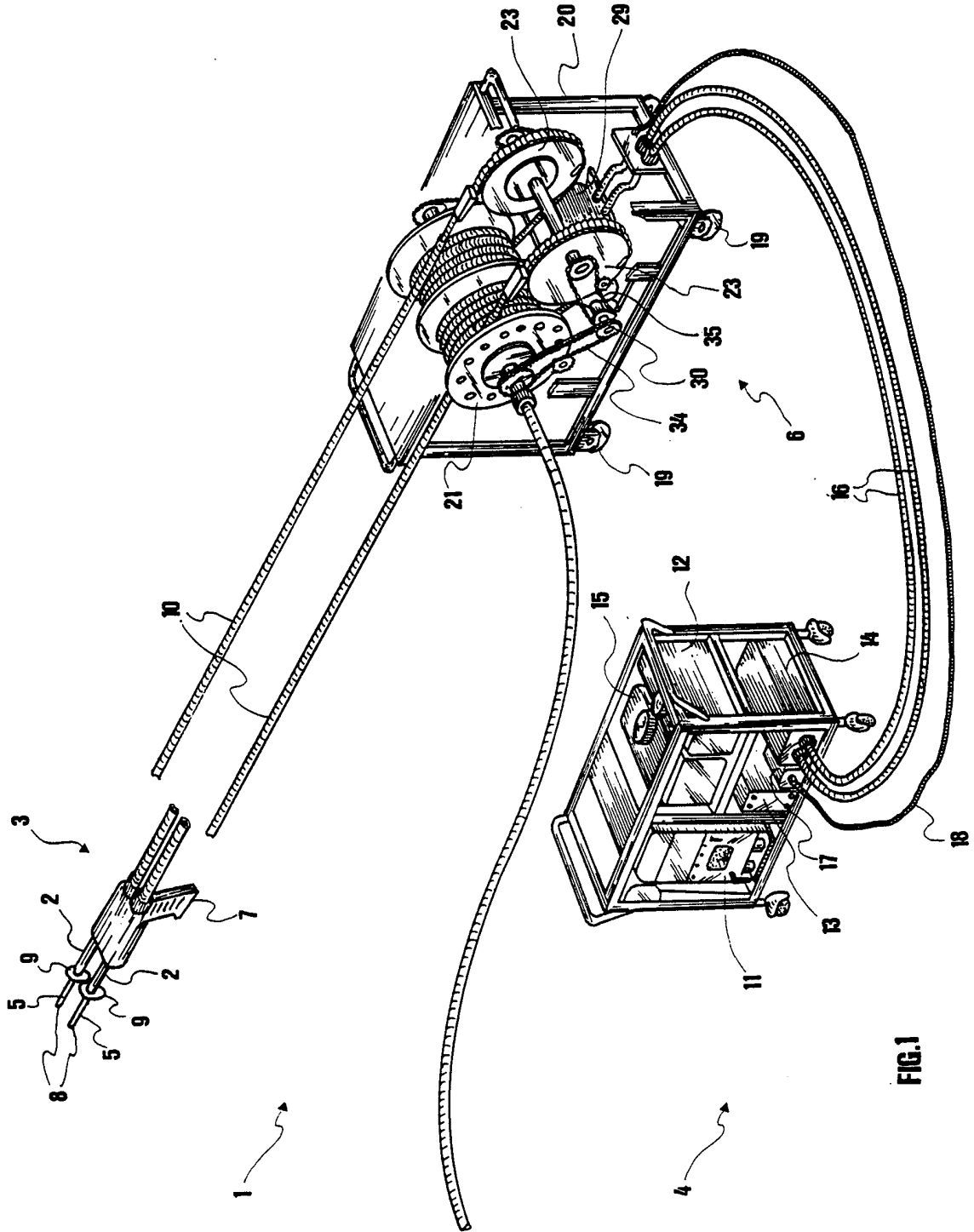

FIG. 1

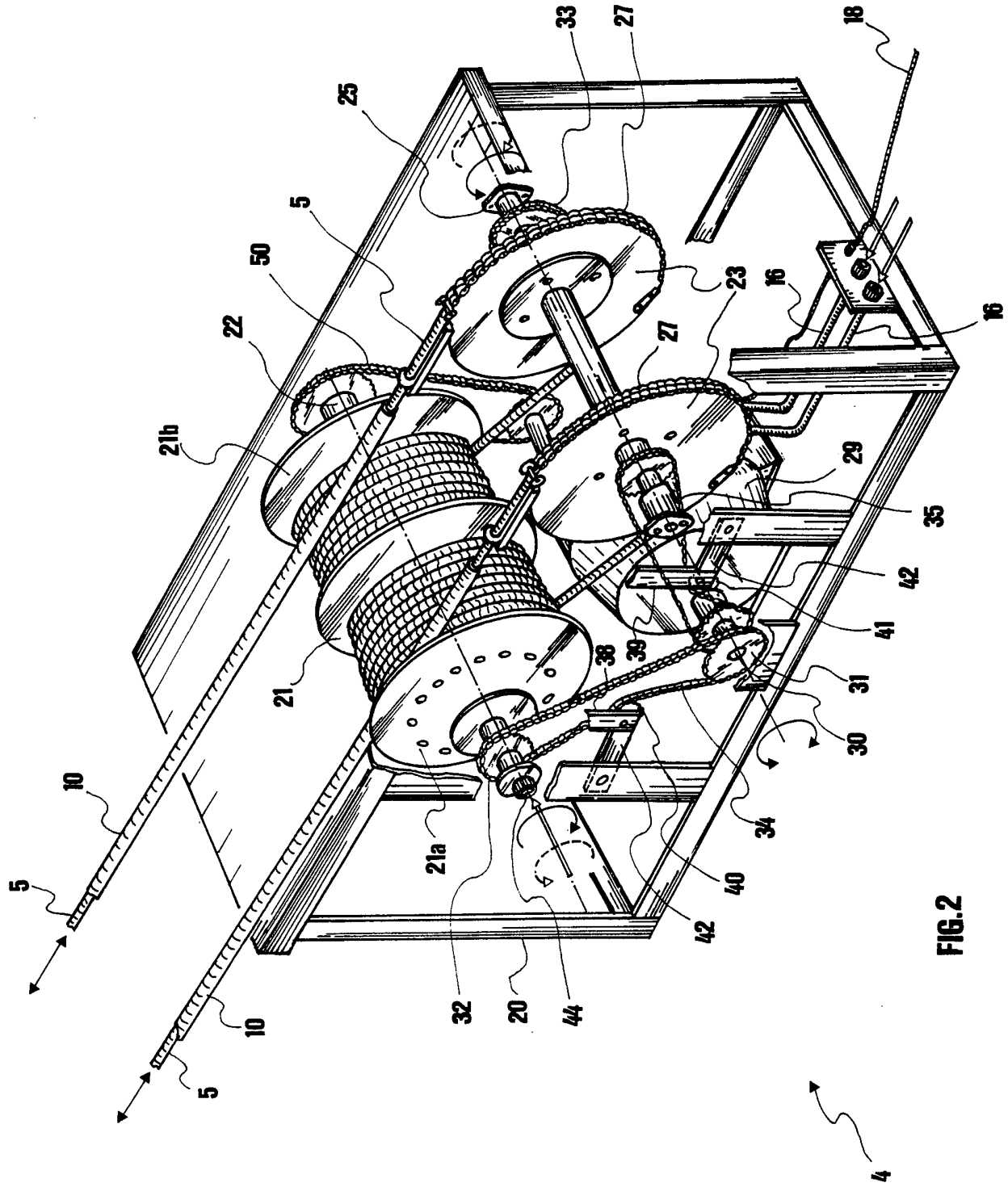

FIG. 2

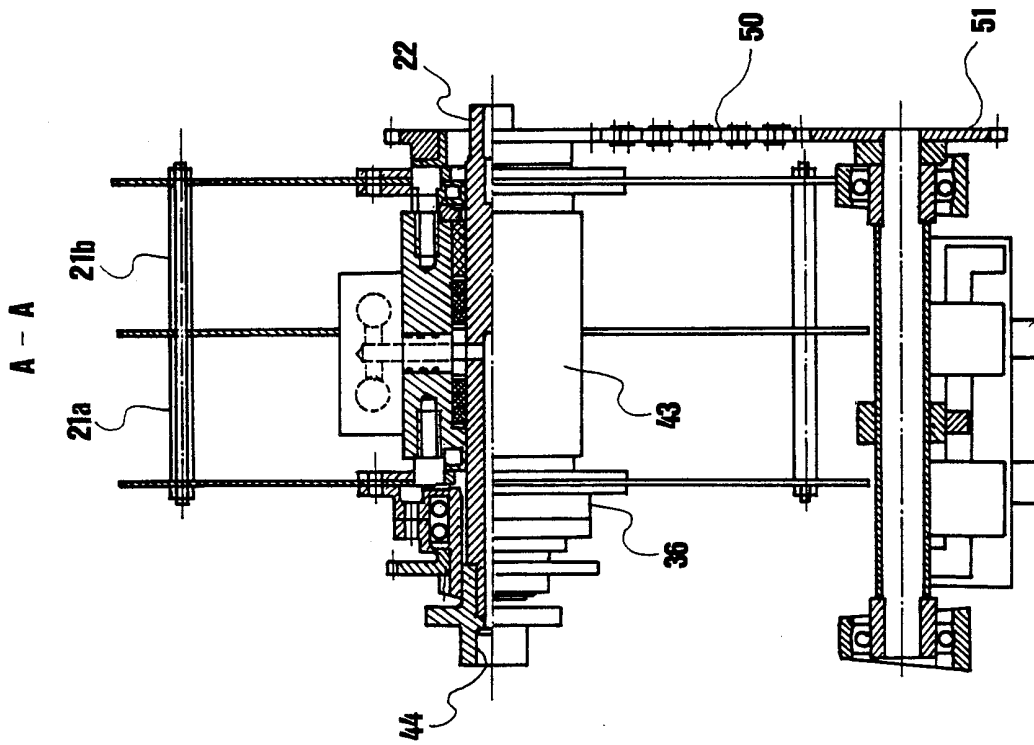

FIG. 4

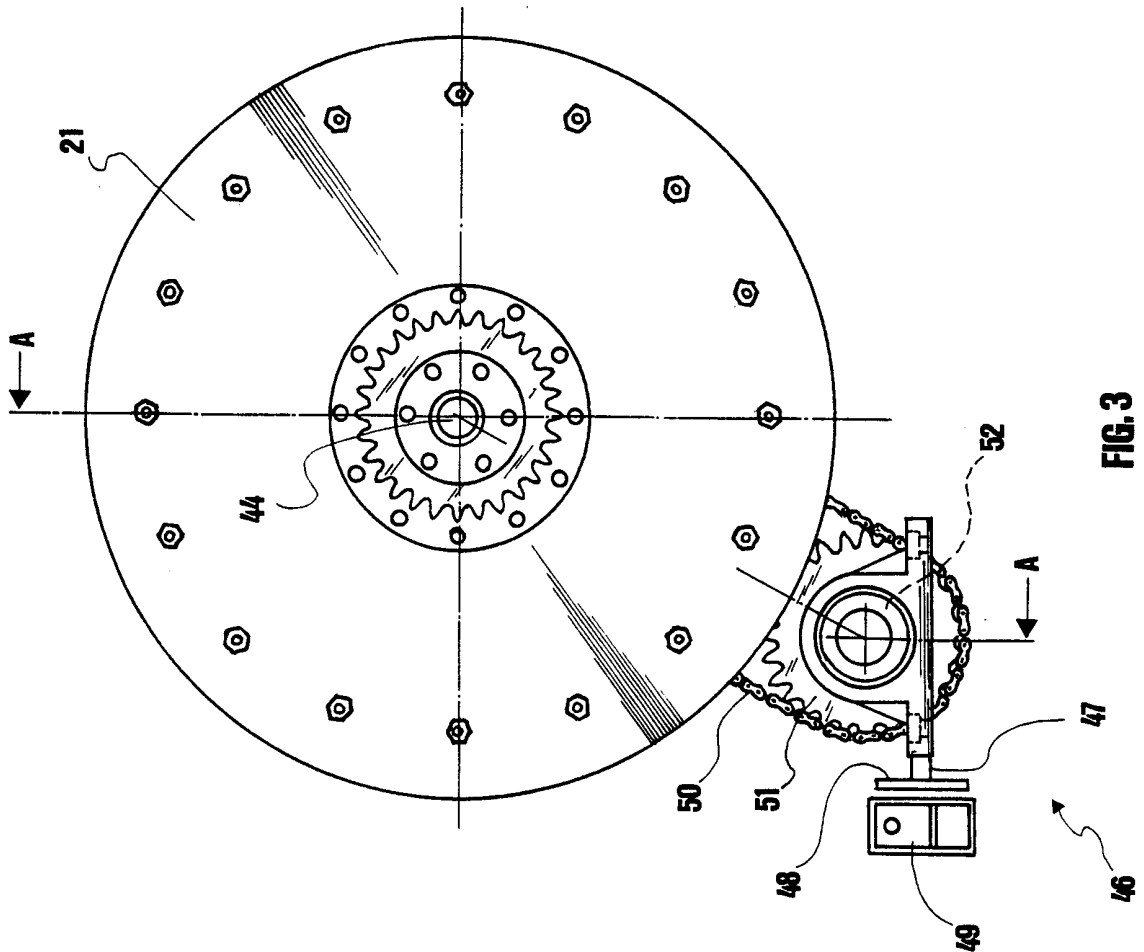

FIG. 3

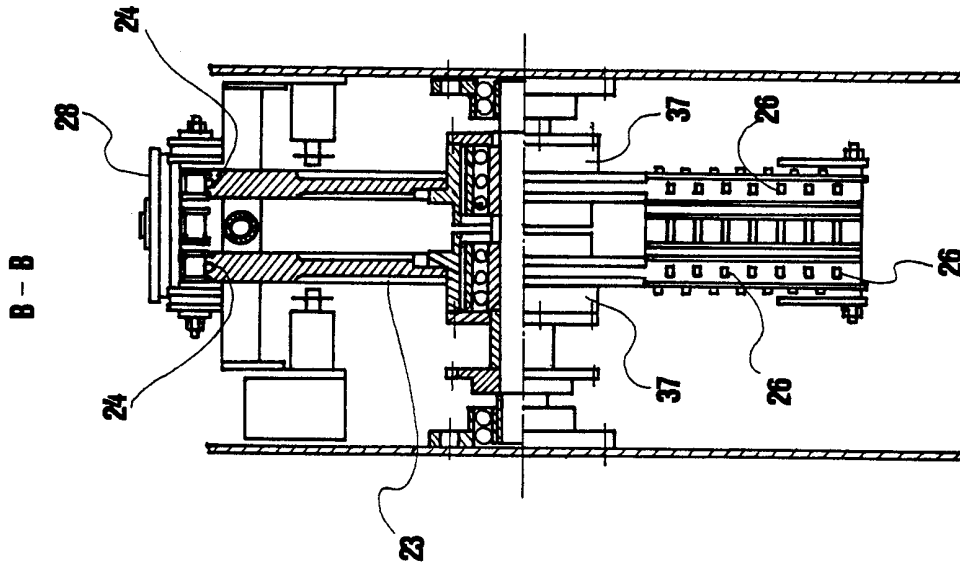

FIG. 6

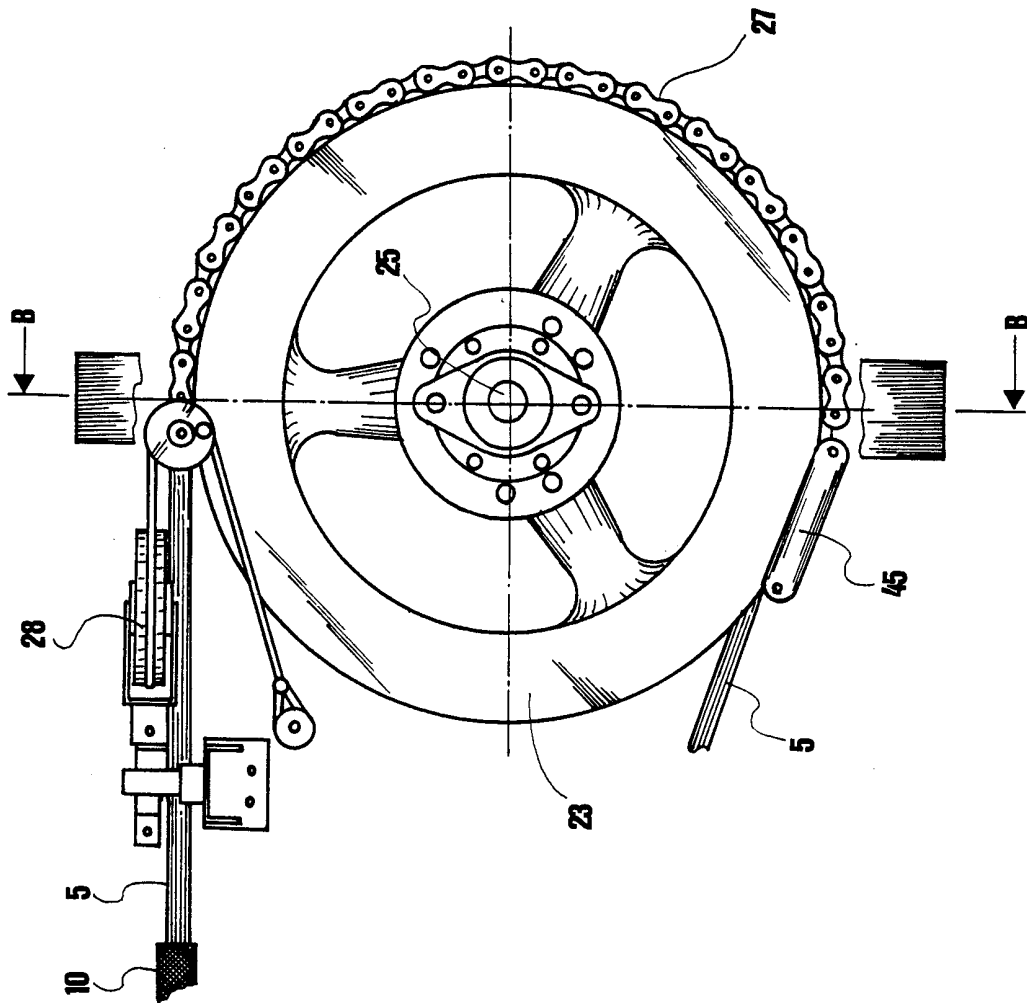

FIG. 5

# INTERNATIONAL SEARCH REPORT

International Application No

PCT/IT 98/00253

<b>A. CLASSIFICATION OF SUBJECT MATTER</b> IPC 6 F28G15/04 B08B9/04 B65H75/44				
According to International Patent Classification (IPC) or to both national classification and IPC				
<b>B. FIELDS SEARCHED</b>				
Minimum documentation searched (classification system followed by classification symbols) IPC 6 F28G B08B B65H				
Documentation searched other than minimum documentation to the extent that such documents are included in the fields searched				
Electronic data base consulted during the international search (name of data base and, where practical, search terms used)				
<b>C. DOCUMENTS CONSIDERED TO BE RELEVANT</b>				
Category °	Citation of document, with indication, where appropriate, of the relevant passages	Relevant to claim No.		
A	EP 0 050 362 A (WALCKER) 28 April 1982 see page 12, line 26 - page 15, line 33 see figures 6,7 ---	1		
A	EP 0 446 653 A (MIGEN) 18 September 1991 cited in the application see column 4, line 47 - column 5, line 22 see figures 1,2 ---	1		
A	US 5 022 463 A (BOISTURE) 11 June 1991 see abstract; figures ---	1		
A	GB 2 086 830 A (MOWLEM) 19 May 1982 -----			
<input type="checkbox"/> Further documents are listed in the continuation of box C.				
<input checked="" type="checkbox"/> Patent family members are listed in annex.				
° Special categories of cited documents :				
<table style="width: 100%; border: none;"> <tr> <td style="width: 50%; border: none; vertical-align: top;">                     "A" document defining the general state of the art which is not considered to be of particular relevance                      "E" earlier document but published on or after the international filing date                      "L" document which may throw doubts on priority claim(s) or which is cited to establish the publication date of another citation or other special reason (as specified)                      "O" document referring to an oral disclosure, use, exhibition or other means                      "P" document published prior to the international filing date but later than the priority date claimed                 </td> <td style="width: 50%; border: none; vertical-align: top;">                     "T" later document published after the international filing date or priority date and not in conflict with the application but cited to understand the principle or theory underlying the invention                      "X" document of particular relevance; the claimed invention cannot be considered novel or cannot be considered to involve an inventive step when the document is taken alone                      "Y" document of particular relevance; the claimed invention cannot be considered to involve an inventive step when the document is combined with one or more other such documents, such combination being obvious to a person skilled in the art.                      "&amp;" document member of the same patent family                 </td> </tr> </table>			"A" document defining the general state of the art which is not considered to be of particular relevance "E" earlier document but published on or after the international filing date "L" document which may throw doubts on priority claim(s) or which is cited to establish the publication date of another citation or other special reason (as specified) "O" document referring to an oral disclosure, use, exhibition or other means "P" document published prior to the international filing date but later than the priority date claimed	"T" later document published after the international filing date or priority date and not in conflict with the application but cited to understand the principle or theory underlying the invention "X" document of particular relevance; the claimed invention cannot be considered novel or cannot be considered to involve an inventive step when the document is taken alone "Y" document of particular relevance; the claimed invention cannot be considered to involve an inventive step when the document is combined with one or more other such documents, such combination being obvious to a person skilled in the art. "&" document member of the same patent family
"A" document defining the general state of the art which is not considered to be of particular relevance "E" earlier document but published on or after the international filing date "L" document which may throw doubts on priority claim(s) or which is cited to establish the publication date of another citation or other special reason (as specified) "O" document referring to an oral disclosure, use, exhibition or other means "P" document published prior to the international filing date but later than the priority date claimed	"T" later document published after the international filing date or priority date and not in conflict with the application but cited to understand the principle or theory underlying the invention "X" document of particular relevance; the claimed invention cannot be considered novel or cannot be considered to involve an inventive step when the document is taken alone "Y" document of particular relevance; the claimed invention cannot be considered to involve an inventive step when the document is combined with one or more other such documents, such combination being obvious to a person skilled in the art. "&" document member of the same patent family			
Date of the actual completion of the international search  <div style="text-align: center; font-size: 1.2em;">26 May 1999</div>		Date of mailing of the international search report  <div style="text-align: center; font-size: 1.2em;">04/06/1999</div>		
Name and mailing address of the ISA European Patent Office, P.B. 5818 Patentlaan 2 NL - 2280 HV Rijswijk Tel. (+31-70) 340-2040, Tx. 31 651 epo nl, Fax: (+31-70) 340-3016		Authorized officer  <div style="text-align: center; font-size: 1.2em;">Leitner, J</div>		

# INTERNATIONAL SEARCH REPORT

Information on patent family members

International Application No

PCT/IT 98/00253

Patent document cited in search report	Publication date	Patent family member(s)	Publication date
EP 50362 A	28-04-1982	DE 3039648 A	06-05-1982
EP 446653 A	18-09-1991	IT 1239357 B	20-10-1993
		AT 129483 T	15-11-1995
		DE 69114032 D	30-11-1995
		DE 69114032 T	11-04-1996
		ES 2081378 T	01-03-1996
		US 5183218 A	02-02-1993
US 5022463 A	11-06-1991	US 5002120 A	26-03-1991
		US 5129455 A	14-07-1992
		US 5031691 A	16-07-1991
		US 5067558 A	26-11-1991
GB 2086830 A	19-05-1982	AU 7695281 A	13-05-1982
		ZA 8107539 A	27-10-1982