



- (51) International Patent Classification:
G11C 11/15 (2006.01)
- (21) International Application Number:
PCT/US2012/023681
- (22) International Filing Date:
2 February 2012 (02.02.2012)
- (25) Filing Language: English
- (26) Publication Language: English
- (30) Priority Data:
13/023,441 8 February 2011 (08.02.2011) US
- (71) Applicant (for all designated States except US): **CROCUS TECHNOLOGY INC.** [US/US]; 710 Lakeway Drive, Suite 100, Sunnyvale, California 94085 (US).
- (72) Inventors; and
- (75) Inventors/Applicants (for US only): **BERGER, Neal** [US/US]; 22623 Woodridge Court, Cupertino, California 95014 (US). **EL BARAJI, Mourad** [MA/US]; 1235 Wildwood Avenue, #392, Sunnyvale, California 94089 (US).
- (74) Agents: **LIU, Cliff Z.** et al.; Cooley LLP, 777 6th Street, Suite 1100, Washington, District of Columbia 20001 (US).

(81) Designated States (unless otherwise indicated, for every kind of national protection available): AE, AG, AL, AM, AO, AT, AU, AZ, BA, BB, BG, BH, BR, BW, BY, BZ, CA, CH, CL, CN, CO, CR, CU, CZ, DE, DK, DM, DO, DZ, EC, EE, EG, ES, FI, GB, GD, GE, GH, GM, GT, HN, HR, HU, ID, IL, IN, IS, JP, KE, KG, KM, KN, KP, KR, KZ, LA, LC, LK, LR, LS, LT, LU, LY, MA, MD, ME, MG, MK, MN, MW, MX, MY, MZ, NA, NG, NI, NO, NZ, OM, PE, PG, PH, PL, PT, QA, RO, RS, RU, RW, SC, SD, SE, SG, SK, SL, SM, ST, SV, SY, TH, TJ, TM, TN, TR, TT, TZ, UA, UG, US, UZ, VC, VN, ZA, ZM, ZW.

(84) Designated States (unless otherwise indicated, for every kind of regional protection available): ARIPO (BW, GH, GM, KE, LR, LS, MW, MZ, NA, RW, SD, SL, SZ, TZ, UG, ZM, ZW), Eurasian (AM, AZ, BY, KG, KZ, MD, RU, TJ, TM), European (AL, AT, BE, BG, CH, CY, CZ, DE, DK, EE, ES, FI, FR, GB, GR, HR, HU, IE, IS, IT, LT, LU, LV, MC, MK, MT, NL, NO, PL, PT, RO, RS, SE, SI, SK, SM, TR), OAPI (BF, BJ, CF, CG, CI, CM, GA, GN, GQ, GW, ML, MR, NE, SN, TD, TG).

Declarations under Rule 4.17:

— as to applicant's entitlement to apply for and be granted a patent (Rule 4.17(ii))

[Continued on next page]

(54) Title: MEMORY DEVICES WITH SERIES-INTERCONNECTED MAGNETIC RANDOM ACCESS MEMORY CELLS

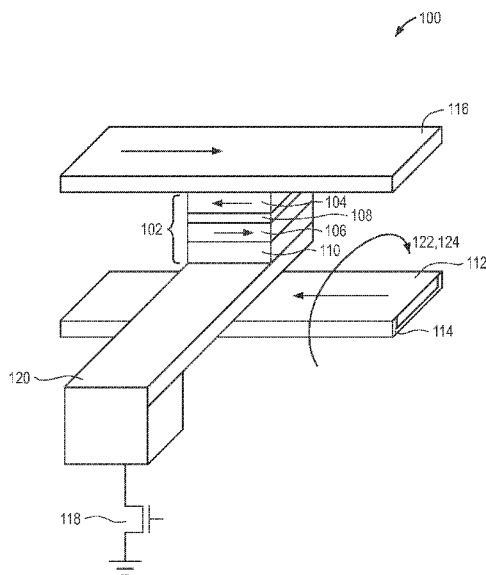

FIG. 1

(57) Abstract: A memory device includes magnetic random access memory ("MRAM") cells that are electrically connected in series, each one of the MRAM cells having a storage magnetization direction and a sense magnetization direction. During a write operation, multiple ones of the MRAM cells are written in parallel by switching the storage magnetization directions of the MRAM cells. During a read operation, a particular one of the MRAM cells is read by varying the sense magnetization direction of the particular one of the MRAM cells, relative to the storage magnetization direction of the particular one of the MRAM cells.



Published:

- *without international search report and to be republished upon receipt of that report (Rule 48.2(g))*

MEMORY DEVICES WITH SERIES-INTERCONNECTED MAGNETIC RANDOM ACCESS MEMORY CELLS

FIELD OF THE INVENTION

[0001] The invention relates generally to memory devices. More particularly, the invention relates to memory devices with series-interconnected magnetic random access memory (“MRAM”) cells.

BACKGROUND

[0002] MRAM devices have become the subject of increasing interest, in view of the discovery of magnetic tunnel junctions having a strong magnetoresistance at ambient temperatures. MRAM devices offer a number of benefits, such as faster speed of writing and reading, non-volatility, and insensitivity to ionizing radiations. Consequently, MRAM devices are increasingly replacing memory devices that are based on a charge state of a capacitor, such as dynamic random access memory devices and flash memory devices.

[0003] In a conventional implementation, a MRAM device includes an array of MRAM cells, each one of which includes a magnetic tunnel junction formed of a pair of ferromagnetic layers separated by a thin insulating layer. One ferromagnetic layer, the so-called reference layer, is characterized by a magnetization with a fixed direction, and the other ferromagnetic layer, the so-called storage layer, is characterized by a magnetization with a direction that is varied upon writing of the device, such as by applying a magnetic field. When the respective magnetizations of the reference layer and the storage layer are antiparallel, a resistance of the magnetic tunnel junction is high, namely having a resistance value R_{\max} corresponding to a high logic state “1”. On the other hand, when the respective magnetizations are parallel, the resistance of the magnetic tunnel junction is low, namely having a resistance value R_{\min} corresponding to a low logic state “0”. A logic state of a MRAM cell is read by comparing its resistance value to a reference resistance value R_{ref} , which is derived from a reference cell or a group of reference cells and represents an in-between resistance value between that of the high logic state “1” and the low logic state “0”.

[0004] In a conventional MRAM cell, a reference layer is typically exchange biased by an adjacent antiferromagnetic layer, which is characterized by a threshold temperature T_{BR} of the antiferromagnetic layer. Below the threshold temperature T_{BR} , a magnetization of the reference layer is pinned by the exchange bias of the antiferromagnetic

layer, thereby retaining the magnetization of the reference layer in a fixed direction. Above the threshold temperature T_{BR} , the exchange bias substantially vanishes, thereby unpinning the magnetization of the reference layer. Consequently, and in order to avoid data loss, an operation temperature window of the conventional MRAM cell has an upper bound defined by the threshold temperature T_{BR} .

[0005] In the case of a MRAM cell that is implemented for thermally assisted switching (“TAS”), a storage layer also is typically exchange biased by another antiferromagnetic layer, which is adjacent to the storage layer and is characterized by a threshold temperature T_{BS} that is smaller than the threshold temperature T_{BR} . Below the threshold temperature T_{BS} , a magnetization of the storage layer is pinned by the exchange bias, thereby inhibiting writing of the storage layer. Writing is carried out by heating the MRAM cell above the threshold temperature T_{BS} (but below T_{BR}), thereby unpinning the magnetization of the storage layer to allow writing, such as by applying a magnetic field. The MRAM cell is then cooled to below the threshold temperature T_{BS} with the magnetic field applied, such that the magnetization of the storage layer is “frozen” in the written direction.

[0006] While offering a number of benefits, a conventional TAS-type MRAM device suffers from certain deficiencies. Specifically, a write operation temperature window is defined by $T_{BR} - T_{BS}$ and, therefore, is bounded by the threshold temperature T_{BR} at the upper end and the threshold temperature T_{BS} at the lower end. Because of practical constraints on antiferromagnetic materials for exchange bias, the write operation temperature window can be rather limited, such as to a range less than 200°C or less than 150°C . Moreover, in the case of an array of TAS-type MRAM cells, characteristics of individual cells can vary across the array due to manufacturing variability. This variability can result in a distribution of the threshold temperatures T_{BS} and T_{BR} for the array, which, for example, can amount up to $\pm 30^{\circ}\text{C}$, thereby further reducing the write operation temperature window. In addition, this variability can impact a resistance of magnetic tunnel junctions across the array and can result in a distribution of the resistance values R_{\min} and R_{\max} for the array, thereby complicating a comparison between a measured resistance value of an individual cell and a reference resistance value R_{ref} during reading. Consequently, a tight tolerance control can be required during manufacturing, and this tight tolerance control can translate into lower manufacturing yields and higher manufacturing costs.

[0007] It is against this background that a need arose to develop the memory devices and related methods described herein.

SUMMARY

[0008] One aspect of the invention relates to a memory device. In one embodiment, the memory device includes MRAM cells that are electrically connected in series, each one of the MRAM cells having a storage magnetization direction and a sense magnetization direction. During a write operation, multiple ones of the MRAM cells are written in parallel by switching the storage magnetization directions of the MRAM cells. During a read operation, a particular one of the MRAM cells is read by varying the sense magnetization direction of the particular one of the MRAM cells, relative to the storage magnetization direction of the particular one of the MRAM cells.

[0009] Another aspect of the invention relates to a method of operating a memory device. In one embodiment, the method includes providing series-interconnected MRAM cells in the memory device. The method also includes, during a write operation, switching a storage magnetization direction of each one of the MRAM cells from an initial logic state to another logic state to store a respective portion of a multi-bit data value. The method further includes, during a read operation, varying a sense magnetization direction of a selected one of the MRAM cells, relative to the storage magnetization direction of the selected one of the MRAM cells, to determine the portion of the multi-bit data value stored by the selected one of the MRAM cells.

[0010] Other aspects and embodiments of the invention are also contemplated. The foregoing summary and the following detailed description are not meant to restrict the invention to any particular embodiment but are merely meant to describe some embodiments of the invention.

BRIEF DESCRIPTION OF THE DRAWINGS

[0011] For a better understanding of the nature and objects of some embodiments of the invention, reference should be made to the following detailed description taken in conjunction with the accompanying drawings.

[0012] FIG. 1 illustrates a memory device including a MRAM cell, according to an embodiment of the invention.

[0013] FIG. 2 illustrates a memory device including multiple, series-interconnected MRAM cells arranged in a vertical stack, according to another embodiment of the invention.

[0014] FIG. 3 illustrates a memory device including multiple, series-interconnected MRAM cells arranged in a horizontal array, according to a further embodiment of the invention.

DETAILED DESCRIPTION

Definitions

[0015] The following definitions apply to some of the aspects described with respect to some embodiments of the invention. These definitions may likewise be expanded upon herein.

[0016] As used herein, the singular terms “a,” “an,” and “the” include plural referents unless the context clearly dictates otherwise. Thus, for example, reference to an object can include multiple objects unless the context clearly dictates otherwise.

[0017] As used herein, the term “set” refers to a collection of one or more objects. Thus, for example, a set of objects can include a single object or multiple objects. Objects of a set also can be referred to as members of the set. Objects of a set can be the same or different. In some instances, objects of a set can share one or more common characteristics.

[0018] As used herein, the terms “substantially” and “substantial” refer to a considerable degree or extent. When used in conjunction with an event or circumstance, the terms can refer to instances in which the event or circumstance occurs precisely as well as instances in which the event or circumstance occurs to a close approximation, such as accounting for typical manufacturing tolerances or variability of the embodiments described herein.

[0019] As used herein, the term “adjacent” refers to being near or adjoining. Adjacent objects can be spaced apart from one another or can be in actual or direct contact with one another. In some instances, adjacent objects can be formed integrally with one another.

[0020] As used herein, the terms “connect,” “connected,” and “connection” refer to an operational coupling or linking. Connected objects can be directly coupled to one another or can be indirectly coupled to one another, such as via another set of objects.

[0021] As used herein, the term “main group element” refers to a chemical element in any of Group IA (or Group 1), Group IIA (or Group 2), Group IIIA (or Group 13), Group IVA (or Group 14), Group VA (or Group 15), Group VIA (or Group 16), Group VIIA (or Group 17), and Group VIIIA (or Group 18). A main group element is also sometimes referred to as a *s*-block element or a *p*-block element.

[0022] As used herein, the term “transition metal” refers to a chemical element in any of Group IVB (or Group 4), Group VB (or Group 5), Group VIB (or Group 6), Group VIIB (or Group 7), Group VIIIB (or Groups 8, 9, and 10), Group IB (or Group 11), and Group IIB (or Group 12). A transition metal is also sometimes referred to as a *d*-block element.

[0023] As used herein, the term “rare earth element” refers to any of Sc, Y, La, Ce, Pr, Nd, Pm, Sm, Eu, Gd, Tb, Dy, Ho, Er, Tm, Yb, and Lu.

MRAM Devices

[0024] Attention first turns to FIG. 1, which illustrates a memory device implemented in accordance with an embodiment of the invention. In the illustrated embodiment, the memory device is a MRAM device 100 that includes a MRAM cell 102. For ease of presentation and to motivate certain benefits and functionalities of the MRAM device 100 and other MRAM devices, the single MRAM cell 102 is illustrated in FIG. 1, although it is contemplated that multiple MRAM cells can be included, such as in an interconnected fashion.

[0025] In the illustrated embodiment, the MRAM cell 102 is implemented for self-referenced operations, in which a read operation can be carried out based on a relative alignment of magnetizations within the MRAM cell 102 and without requiring a comparison to an external resistance value of a reference cell or a group of reference cells. As further explained below, the self-referenced implementation of the MRAM cell 102 allows the omission of a reference layer with a fixed magnetization and, therefore, allows the operation of the MRAM cell 102 in the absence of, or without regard to, a threshold temperature T_{BR} . In such manner, an operation temperature window of the MRAM device 100 can be greatly expanded, such as to allow operation under high ambient temperatures or to allow a faster speed of writing. Moreover, the MRAM device 100 can be afforded with a greater insensitivity to manufacturing variability, thereby increasing manufacturing yields and lowering manufacturing costs. Furthermore, the self-referenced implementation of the

MRAM cell 102 allows the MRAM cell 102 to be interconnected with other MRAM cells that are similarly implemented in a vertical stack or a horizontal array, as further explained below.

[0026] The MRAM cell 102 is implemented as a magnetic tunnel junction, and includes a sense layer 104, a storage layer 106, and a spacer layer 108 that is disposed between the sense layer 104 and the storage layer 106. Other implementations of the MRAM cell 102 are contemplated. For example, the relative positioning of the sense layer 104 and the storage layer 106 can be reversed, with the storage layer 106 disposed above the sense layer 104.

[0027] Each of the sense layer 104 and the storage layer 106 includes, or is formed of, a magnetic material and, in particular, a magnetic material of the ferromagnetic type. A ferromagnetic material can be characterized by a substantially planar magnetization with a particular coercivity, which is indicative of a magnitude of a magnetic field to reverse the magnetization after it is driven to saturation in one direction. In general, the sense layer 104 and the storage layer 106 can include the same ferromagnetic material or different ferromagnetic materials. As illustrated in FIG. 1, the sense layer 104 includes a soft ferromagnetic material, namely one having a relatively low coercivity, such as no greater than about 0.01 oersted, while the storage layer 106 includes a hard ferromagnetic material, namely one having a relatively high coercivity, such as greater than about 0.01 oersted. In such manner, a magnetization of the sense layer 104 can be readily varied under low-intensity magnetic fields during read operations, while a magnetization of the storage layer 106 remains stable. Suitable ferromagnetic materials include transition metals, rare earth elements, and their alloys, either with or without main group elements. For example, suitable ferromagnetic materials include iron ("Fe"), cobalt ("Co"), nickel ("Ni"), and their alloys, such as permalloy (or $\text{Ni}_{80}\text{Fe}_{20}$); alloys based on Ni, Fe, and boron ("B"); $\text{Co}_{90}\text{Fe}_{10}$; and alloys based on Co, Fe, and B. In some instances, alloys based on Ni and Fe (and optionally B) can have a smaller coercivity than alloys based on Co and Fe (and optionally B). A thickness of each of the sense layer 104 and the storage layer 106 can be in the nanometer ("nm") range, such as from about 1 nm to about 20 nm or from about 1 nm to about 10 nm. Other implementations of the sense layer 104 and the storage layer 106 are contemplated. For example, either, or both, of the sense layer 104 and the storage layer 106 can include multiple sub-layers in a fashion similar to that of the so-called synthetic antiferromagnetic layer.

[0028] The spacer layer 108 functions as a tunnel barrier, and includes, or is formed of, an insulating material. Suitable insulating materials include oxides, such as aluminum oxide (e.g., Al_2O_3) and magnesium oxide (e.g., MgO). A thickness of the spacer layer 108 can be in the nm range, such as from about 1 nm to about 10 nm.

[0029] In the illustrated embodiment, the MRAM cell 102 is implemented to store data corresponding to one of a pair of logic states. In other words, the MRAM cell 102 is a single-bit cell that stores a single-bit data value, although multi-bit implementations for storing multi-bit data values are also contemplated. In accordance with the single-bit implementation of the MRAM cell 102, the storage layer 106 has a storage magnetization that is switchable between a pair of directions corresponding to the pair of logic states. Referring to FIG. 1, the MRAM cell 102 also includes a pinning layer 110, which is disposed adjacent to the storage layer 106 and, through exchange bias, stabilizes the storage magnetization along a particular one of the pair of directions when a temperature within, or in the vicinity of, the pinning layer 110 is lower than a threshold temperature T_{BS} , such as a blocking temperature, a Neel temperature, or another threshold temperature. The pinning layer 110 unpins, or decouples, the storage magnetization direction when the temperature is at, or above, the threshold temperature T_{BS} , thereby allowing the storage magnetization direction to be switched to another one of the pair of directions. In contrast, such a pinning layer is omitted adjacent to the sense layer 104, and, as a result, the sense layer 104 has a sense magnetization direction that is unpinned and is readily varied, with the substantial absence of exchange bias. The pinning layer 110 includes, or is formed of, a magnetic material and, in particular, a magnetic material of the antiferromagnetic type. Suitable antiferromagnetic materials include transition metals and their alloys. For example, suitable antiferromagnetic materials include alloys based on manganese (“Mn”), such as alloys based on iridium (“Ir”) and Mn (e.g., IrMn); alloys based on Fe and Mn (e.g., FeMn); alloys based on platinum (“Pt”) and Mn (e.g., PtMn); and alloys based on Ni and Mn (e.g., NiMn). In some instances, the threshold temperature T_{BS} of alloys based on Ir and Mn (or based on Fe and Mn) can be in the range of about 120°C to about 220°C or about 150°C to about 200°C , and can be smaller than the threshold temperature T_{BS} of alloys based on Pt and Mn (or based on Ni and Mn), which can be in the range of about 300°C to about 350°C . Because the sense magnetization direction is unpinned, the threshold temperature T_{BS} can be selected to accommodate a desired application, in the absence of, or without regard to, a threshold

temperature T_{BR} that would otherwise set an upper bound of an operation temperature window.

[0030] Still referring to FIG. 1, the MRAM device 100 also includes a set of traces (or strip conductors) to provide write and read functionality. Specifically, a bit line 116 is electrically connected to the MRAM cell 102 on the side of the sense layer 104 and is substantially parallel to a field line 112, which is disposed below and magnetically connected to the MRAM cell 102 on the side of the storage layer 106. In the illustrated embodiment, the field line 112 includes a cladding 114, which forms an exterior of the field line 112 adjacent to the sides and the bottom of the field line 112 and serves to concentrate a magnetic field towards the MRAM cell 102. The cladding 114 includes, or is formed of, a magnetic material and, in particular, a magnetic material of the ferromagnetic type. The MRAM device 100 further includes a transistor 118, which is electrically connected, through a strap 120, to the MRAM cell 102 on the side of the storage layer 106. The transistor 118 is switchable between a blocked mode (OFF) and a saturated mode (ON), thereby allowing the flow of a current through the MRAM cell 102.

[0031] During a TAS-type write operation, the MRAM cell 102 is heated by applying a heating current through the MRAM cell 102 via the bit line 116, with the transistor 118 in a saturated mode. The MRAM cell 102 is heated to a temperature above the threshold temperature T_{BS} of the pinning layer 110, such that a magnetization of the storage layer 106 is unpinned. Simultaneously or after a short time delay, the field line 112 is activated to induce a write magnetic field 122 to switch the storage magnetization from an initial direction to another direction. Specifically, a write current is applied through the field line 112 to induce the write magnetic field 122 to switch the storage magnetization direction accordingly. Because the storage magnetization direction can be aligned according to the write magnetic field 122, the storage magnetization direction can be switched between multiple directions according to a write encoding scheme. One possible write encoding scheme is implemented with a pair of directions that are displaced by about 180° , such that the logic state "0" is assigned to one of the pair of directions, and the logic state "1" is assigned to another one of the pair of directions.

[0032] Once the storage magnetization is switched to a written direction, the transistor 118 is switched to a blocked mode to inhibit current flow through the MRAM cell 102, thereby cooling the MRAM cell 102. The write magnetic field 122 can be maintained during cooling of the MRAM cell 102, and can be deactivated once the MRAM cell 102 has

cooled below the threshold temperature T_{BS} of the pinning layer 110. Because the storage magnetization direction is pinned by the exchange bias of the pinning layer 110, its orientation remains stable so as to retain the written data.

[0033] Other implementations of write operations are contemplated. For example, the MRAM cell 102 can be implemented with an anisotropic shape having a relatively high aspect ratio, such as about 1.5 or more. In such an anisotropic-shaped implementation of the MRAM cell 102, the storage magnetization direction can be switched and can remain stable, without requiring the pinning layer 110. As another example, a write operation can be carried out by applying a write current through the MRAM cell 102 via the bit line 116, using the so-called spin transfer torque (“STT”) effect. In such a STT-type write operation, the write current can become spin polarized by passing through a polarizing magnetic layer (not illustrated) or through the sense layer 104, and a magnetization of the storage layer 106 can be switched according to a spin-polarized orientation of the write current. Switching of the storage layer magnetization with the spin-polarized write current also can be combined with a TAS-type write operation, such as by heating the MRAM cell 102 above the threshold temperature T_{BS} and then applying the spin-polarized write current through the MRAM cell 102.

[0034] During a read operation of the MRAM cell 102, the field line 112 is activated to induce a read magnetic field 124 to vary a magnetization of the sense layer 104. Specifically, a read current is applied through the field line 112 to induce the read magnetic field 124 to vary the sense magnetization direction accordingly. Because the sense layer 104 is subject to little or no exchange bias, the sense magnetization direction can be readily varied under low-intensity magnetic fields and at a temperature below the threshold temperature T_{BS} , while the storage magnetization remains stable in a written direction.

[0035] For certain implementations, the read operation of the MRAM cell 102 is carried out in multiple read cycles, in which the field line 112 is activated to induce the read magnetic field 124 that is compatible with a write encoding scheme. Because the sense magnetization direction can be aligned according to the read magnetic field 124, the sense magnetization direction can be successively switched between multiple directions according to the write encoding scheme, such as one in which a pair of directions are displaced by about 180° . In such manner, the sense magnetization can be switched from an initial direction, which corresponds to one of the pair of directions of the write encoding scheme, to another

direction, which corresponds to another one of the pair of directions of the write encoding scheme.

[0036] As part of each read cycle, a degree of alignment between the sense magnetization direction and the storage magnetization direction is determined by applying a sense current through the MRAM cell 102 via the bit line 116, with the transistor 118 in a saturated mode. Measuring a resulting voltage across the MRAM cell 102 when the sense current is applied yields a resistance value of the MRAM cell 102 for a particular read cycle and for a particular direction of the sense magnetization. Alternatively, a resistance value can be determined by applying a voltage across the MRAM cell 102 and measuring a resulting current. When the respective magnetizations of the sense layer 104 and the storage layer 106 are antiparallel, a resistance value of the MRAM cell 102 typically corresponds to a maximum value, namely R_{\max} , and, when the respective magnetizations are parallel, a resistance value of the MRAM cell 102 typically corresponds to a minimum value, namely R_{\min} . When the respective magnetizations are between antiparallel and parallel, a resistance value of the MRAM cell 102 is typically between R_{\max} and R_{\min} . Resistance values for multiple read cycles are processed to determine which sense magnetization direction yielded a minimum resistance value, thereby yielding a written direction of the storage layer 106 and its stored data value based on which logic state is assigned to that written direction. Processing of the resistance values can be carried out using a suitable controller in combination with, for example, a sample/hold circuit.

[0037] The read operation of the MRAM cell 102 explained above is self-referenced, since it can be carried out based on the relative alignment of magnetizations within the MRAM cell 102, without requiring a comparison to a reference cell or a group of reference cells. As a result, the read operation is less prone to complication and errors in view of manufacturing variability. The self-referenced implementation of the MRAM cell 102 also allows the omission of a reference layer with a fixed magnetization and, therefore, allows the operation of the MRAM cell 102 in the absence of, or without regard to, a threshold temperature T_{BR} . In such manner, an operation temperature window of the MRAM cell 102 can be greatly expanded, such as to temperatures up to about 400°C or more. Moreover, and in view of the expanded operation temperature window, a high-intensity heating current can be applied during writing, such as in the form of a pulse having a duration of less than about 10 nanoseconds, thereby allowing a faster speed of writing.

[0038] Other implementations of read operations are contemplated. For example, a faster speed of reading can be achieved with a single read cycle, albeit involving a comparison to a reference resistance value. During the single read cycle, the sense magnetization can be aligned along a predetermined read direction, such as along one of a pair of directions of a write encoding scheme, and a resulting resistance value of the MRAM cell 102 can be compared with a reference resistance value R_{ref} , which represents an in-between resistance value between R_{max} and R_{min} . A written direction of the storage layer 106 and its stored data value can be determined based on whether the resistance value of the MRAM cell 102 is greater than R_{ref} , which indicates an antiparallel alignment with respect to the predetermined read direction, or smaller than R_{ref} , which indicates a parallel alignment with respect to the predetermined read direction. As another example, the sense magnetization can be “wiggled” with respect to a predetermined read direction and without completely reversing its direction, by applying an alternating sense current. Here, the alternating sense current can induce a varying read magnetic field, and a resistance value of the MRAM cell 102 can vary alternatively as the sense magnetization is “wiggled” by the varying read magnetic field. A written direction of the storage layer 106 and its stored data value can be determined based on whether the varying resistance value of the MRAM cell 102 is in phase, or out of phase, with respect to the alternating sense current.

[0039] Attention next turns to FIG. 2, which illustrates a MRAM device 200 implemented in accordance with another embodiment of the invention. In the illustrated embodiment, the MRAM device 200 includes multiple MRAM cells 202a, 202b, and 202c that are arranged in a vertical stack 204a. Adjacent to the vertical stack 204a is another vertical stack 204b, which can include multiple MRAM cells that are arranged in a similar fashion as the MRAM cells 202a, 202b, and 202c. The vertically stacked implementation of the MRAM device 200 allows multiple MRAM cells to be arranged on top of one another, thereby achieving a higher density of the MRAM cells for a given footprint area. While the two vertical stacks 204a and 204b are illustrated in FIG. 2, it is contemplated that more or less vertical stacks can be included in the MRAM device 200. For ease of presentation, the following explanation is primarily directed to the vertical stack 204a, although the explanation is also applicable to other vertical stacks included in the MRAM device 200. Also, certain aspects of the MRAM device 200 and the MRAM cells included in the MRAM device 200 are implemented in a similar fashion as the MRAM device 100 explained with reference to FIG. 1, and those aspects are not repeated below.

[0040] Referring to FIG. 2, the MRAM cells 202a, 202b, and 202c are disposed at respective levels of the vertical stack 204a, with the MRAM cell 202a disposed at a top level (or a third level), the MRAM cell 202b disposed at an intermediate level (or a second level), and the MRAM cell 202c disposed at a bottom level (or a first level). Within the vertical stack 204a, the MRAM cells 202a, 202b, and 202c are electrically connected in series, thereby allowing the flow of a common current through the MRAM cells 202a, 202b, and 202c during write and read operations. During a TAS-type write operation, a common heating current can be applied through the MRAM cells 202a, 202b, and 202c to write multiple ones of the MRAM cells 202a, 202b, and 202c in parallel, resulting in lower power consumption while retaining a desirable speed of writing. In addition, self-referenced implementation of the MRAM cells 202a, 202b, and 202c and the provision of variable sense magnetizations allow an individual one of the MRAM cells 202a, 202b, and 202c to be selected and probed, thereby facilitating read operations of the series-interconnected MRAM cells 202a, 202b, and 202c while retaining the benefits of reduced power consumption.

[0041] In the illustrated embodiment, the MRAM device 200 also includes a set of traces (or strip conductors) and a transistor 216 to provide write and read functionality. Specifically, a bit line 214 is electrically connected in series to the MRAM cells 202a, 202b, and 202c on the side of the MRAM cell 202a, and the transistor 216 is electrically connected in series to the MRAM cells 202a, 202b, and 202c on the side of the MRAM cell 202c. The bit line 214 serves as a common bit line that is shared by the MRAM cells 202a, 202b, and 202c, and the transistor 216 serves as a common transistor that is shared by the MRAM cells 202a, 202b, and 202c. The implementation of such shared bit line 214 and such shared transistor 216 conserves valuable footprint area and lowers manufacturing costs. Referring to FIG. 2, the MRAM device 200 further includes a set of field lines, namely a field line 218a, which is disposed below and magnetically connected to the MRAM cell 202a, a field line 218b, which is disposed below and magnetically connected to the MRAM cell 202b, and a field line 218c, which is disposed below and magnetically connected to the MRAM cell 202c. While not illustrated in FIG. 2, each one of the field lines 218a, 218b, and 218c can include a cladding to concentrate a magnetic field towards a respective one of the MRAM cells 202a, 202b, and 202c.

[0042] Still referring to FIG. 2, components disposed at different levels of the vertical stack 204a are electrically interconnected through a set of traces (or strip conductors) and a set of vias. Specifically, the bit line 214 is electrically connected to the MRAM cell

202a through a via 220. Also, the MRAM cell 202a is electrically connected to the MRAM cell 202b through a strap 206a, a pair of vias 208a and 210a, and a trace 212a, and the MRAM cell 202b is electrically connected to the MRAM cell 202c through a strap 206b, a pair of vias 208b and 210b, and a trace 212b. Likewise, the MRAM cell 202c is electrically connected to the transistor 216 through a strap 206c, a pair of vias 208c and 210c, and a trace 212c. The vias 208a, 208b, 208c, 210a, 210b, and 210c and the traces 212a, 212b, and 212c provide electrical connection functionality as well as spacing to accommodate the field lines 218a, 218b, and 218c.

[0043] Other implementations of the vertical stack 204a are contemplated. For example, while the three levels of the MRAM cells 202a, 202b, and 202c and related components are illustrated in FIG. 2, it is contemplated that more or less levels can be included in the vertical stack 204a. As another example, one or more of the vias 210a, 210b, and 210c can be omitted, while retaining the spacing to accommodate the field lines 218a, 218b, and 218c. As a further example, one or more of the field lines 218a, 218b, and 218c can serve as a common field line that is shared across multiple vertical stacks, such as the vertical stacks 204a and 204b.

[0044] During a TAS-type write operation, the vertical stack 204a is heated by applying a common heating current through the MRAM cells 202a, 202b, and 202c via the bit line 214, with the transistor 216 in a saturated mode. The MRAM cells 202a, 202b, and 202c are heated to a temperature above a threshold temperature T_{BS} , such that storage magnetizations of the MRAM cells 202a, 202b, and 202c are unpinned. Simultaneously or after a short time delay, the field lines 218a, 218b, and 218c are activated to induce write magnetic fields to switch the storage magnetization directions according to a write encoding scheme, such as one with a pair of directions corresponding to the logic state “0” and the logic state “1”. For example, the storage magnetization direction of the MRAM cell 202a can be switched from the logic state “0” to the logic state “1”, the storage magnetization direction of the MRAM cell 202b can be switched from the logic state “1” to the logic state “0”, and the storage magnetization direction of the MRAM cell 202c can be switched from the logic state “0” to the logic state “1”. Once the storage magnetizations are switched to their written directions, the transistor 216 is switched to a blocked mode to inhibit current flow through the vertical stack 204a, thereby cooling the MRAM cells 202a, 202b, and 202c below the threshold temperature T_{BS} and retaining the storage magnetizations along their written directions. In such manner, a multi-bit data value, such as “101”, can be written into the

MRAM cells 202a, 202b, and 202c in a single write cycle, with each one of the MRAM cells 202a, 202b, and 202c storing a respective portion of the multi-bit data value.

[0045] During a read operation, an individual one of the MRAM cells 202a, 202b, and 202c is selectively addressed to determine a respective portion of a multi-bit data value stored by that MRAM cell. In the case that the MRAM cell 202a is read, for example, the field line 218a is activated to induce a read magnetic field to vary a sense magnetization direction of the MRAM cell 202a. During the read operation of the MRAM cell 202a, the field lines 218b and 218c can remain deactivated to reduce power consumption, and sense magnetization directions of the MRAM cells 202b and 202c can remain substantially unchanged, other than possible variations resulting from thermal agitation and possible interactions with the read magnetic field induced by the field line 218a.

[0046] In the illustrated embodiment, the read operation of the MRAM cell 202a is carried out in multiple read cycles, in which the sense magnetization direction of the MRAM cell 202a is successively switched according to a write encoding scheme, such as between a pair of directions corresponding to the logic state "0" and the logic state "1". As part of each read cycle, a degree of alignment between the sense magnetization direction and the storage magnetization direction of the MRAM cell 202a is determined by applying a sense current through the vertical stack 204a via the bit line 214, with the transistor 216 in a saturated mode. Measuring a resulting voltage (or a resulting current) across the vertical stack 204a yields a resistance value of the vertical stack 204a for a particular read cycle and for a particular sense magnetization direction of the MRAM cell 202a. The resistance value of the vertical stack 204a includes a series resistance contribution of the MRAM cells 202a, 202b, and 202c, in which the sense magnetization direction of the MRAM cell 202a is switched, while the sense magnetization directions of the MRAM cells 202b and 202c remain substantially unchanged. When the sense magnetization and the storage magnetization of the MRAM cell 202a are antiparallel, the series resistance contribution of the MRAM cells 202a, 202b, and 202c typically has a maximum value, such as a local maximum value, and, when the magnetizations of the MRAM cell 202a are parallel, the series resistance contribution of the MRAM cells 202a, 202b, and 202c typically has a minimum value, such as a local minimum value. Resistance values for multiple read cycles are processed to determine which sense magnetization direction yielded a minimum resistance value, thereby yielding a written direction of the MRAM cell 202a and its stored portion of a multi-bit data value. By operating in a similar fashion, the MRAM cells 202b and 202c can be addressed to determine

respective portions of the multi-bit data value stored by the MRAM cells 202b and 202c, thereby allowing the multi-bit data value to be read from the vertical stack 204a on a level-by-level basis or a cell-by-cell basis.

[0047] Other implementations of read operations are contemplated. For example, during a read operation of the MRAM cell 202a, the sense magnetization direction of the MRAM cell 202a can be varied, with the field lines 218b and 218c activated to align the sense magnetization directions of the MRAM cells 202b and 202c along a predetermined read direction, such as along one of a pair of directions of a write encoding scheme. In such manner, the MRAM cell 202a can be read, while reducing the impact of variations of the sense magnetization directions of the remaining MRAM cells 202b and 202c. As another example, a multi-bit data value can be written into multiple vertical stacks in parallel, with each one of the vertical stacks storing a respective portion of the multi-bit data value. During a read operation, the multi-bit data value can be read from the vertical stacks in parallel, resulting in a faster speed of reading.

[0048] FIG. 3 illustrates a MRAM device 300 implemented in accordance with a further embodiment of the invention. Certain aspects of the MRAM device 300 are implemented in a similar fashion as the MRAM devices 100 and 200 explained with reference to FIG. 1 and FIG. 2, and those aspects are not repeated below. Referring to FIG. 3, the MRAM device 300 includes multiple MRAM cells 302a, 302b, 302c, and 302d that are arranged in a side-by-side fashion in a horizontal array 304. Within the horizontal array 304, the MRAM cells 302a, 302b, 302c, and 302d are electrically connected in series, thereby allowing the flow of a common current through the MRAM cells 302a, 302b, 302c, and 302d during write and read operations. Although occupying a larger footprint area relative to a vertically stacked implementation, the MRAM device 300 retains the benefits of reduced power consumption, while allowing implementation at lower manufacturing costs and facilitating integration with other types of MRAM cells.

[0049] In the illustrated embodiment, the MRAM device 300 also includes a bit line 314, which is shared by and electrically connected in series to the MRAM cells 302a, 302b, 302c, and 302d on the side of the MRAM cell 302a, and a transistor 316, which is shared by and electrically connected in series to the MRAM cells 302a, 302b, 302c, and 302d on the side of the MRAM cell 302d. Referring to FIG. 3, the bit line 314 is electrically connected to the MRAM cell 302a through a via 308a and a strap 306a. Also, the MRAM cell 302a is electrically connected to the MRAM cell 302b through a pair of vias 310a and

310b and a trace 312a, the MRAM cell 302b is electrically connected to the MRAM cell 302c through a shared strap 306b, and the MRAM cell 302c is electrically connected to the MRAM cell 302d through a pair of vias 310c and 310d and a trace 312b. And, the MRAM cell 302d is electrically connected to the transistor 316 through a strap 306c, a pair of vias 308b and 310e, and a trace 312c. The vias 308a, 308b, and 310e and the trace 312c provide electrical connection functionality as well as spacing to accommodate a set of field lines, namely field lines 318a, 318b, 318c, and 318d, which are disposed below and magnetically connected to respective ones of the MRAM cell 302a, 302b, 302c, and 302d.

[0050] Other implementations of the horizontal array 304 are contemplated. For example, while the four MRAM cells 302a, 302b, 302c, and 302d are illustrated in FIG. 3, it is contemplated that more or less MRAM cells can be included in the horizontal array 304. As another example, the bit line 314 can be disposed above the strap 306a, rather than below the strap 306a. As additional examples, one or more of the vias 310a, 310b, 310c, 310d, and 310e can be omitted, and one or more of the field lines 318a, 318b, 318c, and 318d can serve as a common field line that is shared across multiple horizontal arrays. As a further example, the horizontal array 304 can be implemented in combination with a vertical stack of MRAM cells, such as the vertical stack 204a explained with reference to FIG. 2.

[0051] While the invention has been described with reference to the specific embodiments thereof, it should be understood by those skilled in the art that various changes may be made and equivalents may be substituted without departing from the true spirit and scope of the invention as defined by the appended claims. In addition, many modifications may be made to adapt a particular situation, material, composition of matter, method, or process to the objective, spirit and scope of the invention. All such modifications are intended to be within the scope of the claims appended hereto. In particular, while the methods disclosed herein have been described with reference to particular operations performed in a particular order, it will be understood that these operations may be combined, sub-divided, or re-ordered to form an equivalent method without departing from the teachings of the invention. Accordingly, unless specifically indicated herein, the order and grouping of the operations are not limitations of the invention.

What is claimed is:

1. A memory device comprising:
a plurality of magnetic random access memory (MRAM) cells that are electrically connected in series, each one of the MRAM cells having a storage magnetization direction and a sense magnetization direction,
wherein, during a write operation, multiple ones of the MRAM cells are configured to be written in parallel by switching the storage magnetization directions of the MRAM cells, and
wherein, during a read operation, a particular one of the MRAM cells is configured to be read by varying the sense magnetization direction of the particular one of the MRAM cells, relative to the storage magnetization direction of the particular one of the MRAM cells.
2. The memory device of claim 1, wherein the MRAM cells are arranged in a vertical stack.
3. The memory device of claim 1, wherein the MRAM cells are arranged in a horizontal array.
4. The memory device of claim 1, wherein the storage magnetization direction of each one of the MRAM cells is switchable between a plurality of directions to store at least a portion of a multi-bit data value.
5. The memory device of claim 4, wherein, during the write operation, the multi-bit data value is written into the MRAM cells, with each one of the MRAM cells storing a respective portion of the multi-bit data value.
6. The memory device of claim 5, wherein, during the read operation, the sense magnetization direction of the particular one of the MRAM cells being read is varied to determine the portion of the multi-bit data value stored by the particular one of the MRAM cells.
7. The memory device of claim 1, wherein at least one of the MRAM cells includes:
a sense layer having a sense magnetization direction;

a storage layer having a storage magnetization direction;
a spacer layer disposed between the sense layer and the storage layer; and
a pinning layer disposed adjacent to the storage layer and configured to stabilize the storage magnetization direction with respect to a threshold temperature.

8. The memory device of claim 7, wherein the sense layer includes a first ferromagnetic material, the storage layer includes a second ferromagnetic material, and a coercivity of the first ferromagnetic material is smaller than a coercivity of the second ferromagnetic material.

9. The memory device of claim 1, further comprising a transistor electrically connected in series to the MRAM cells, and wherein the transistor is switchable to allow flow of a current through the MRAM cells.

10. The memory device of claim 9, further comprising a bit line electrically connected in series to the MRAM cells, and wherein, during the write operation, the bit line is configured to apply a heating current to heat the MRAM cells above a threshold temperature to switch the storage magnetization directions of the MRAM cells.

11. The memory device of claim 10, wherein, during the read operation, the bit line is configured to apply a sense current to determine a resistance of the MRAM cells.

12. The memory device of claim 11, wherein, during the read operation, the sense magnetization direction of the particular one of the MRAM cells being read is varied to determine a minimum of the resistance.

13. The memory device of claim 1, further comprising a plurality of field lines that are magnetically connected to respective ones of the MRAM cells, and wherein, during the write operation, each one of the field lines is configured to apply a write current to induce a write magnetic field.

14. The memory device of claim 13, wherein, during the read operation, a particular one of the field lines is selectively activated to apply a read current to induce a read magnetic field, and the sense magnetization direction of the particular one of the MRAM cells being read is varied in accordance with the read magnetic field.

15. The memory device of claim 1, wherein the MRAM cells are arranged in a first vertical stack, and the memory device further comprises a second vertical stack disposed adjacent to the first vertical stack.
16. A method of operating a memory device, comprising:
 - providing a plurality of series-interconnected MRAM cells in the memory device;
 - during a write operation, switching a storage magnetization direction of each one of the MRAM cells from an initial logic state to another logic state to store a respective portion of a multi-bit data value; and
 - during a read operation, varying a sense magnetization direction of a selected one of the MRAM cells, relative to the storage magnetization direction of the selected one of the MRAM cells, to determine the portion of the multi-bit data value stored by the selected one of the MRAM cells.
17. The method of claim 16, further comprising, during the write operation, applying a heating current through the MRAM cells to facilitate switching the storage magnetization directions of the MRAM cells.
18. The method of claim 16, further comprising, during the read operation, inducing a read magnetic field adjacent to the selected one of the MRAM cells to vary the sense magnetization direction of the selected one of the MRAM cells.
19. The method of claim 18, further comprising, during the read operation, applying a sense current through the MRAM cells to determine a resistance value of the MRAM cells, with the resistance value being dependent upon a degree of alignment between the sense magnetization direction and the storage magnetization direction of the selected one of the MRAM cells.
20. The method of claim 19, wherein, during the read operation, the sense magnetization direction of the selected one of the MRAM cells is varied to determine a minimum resistance value.

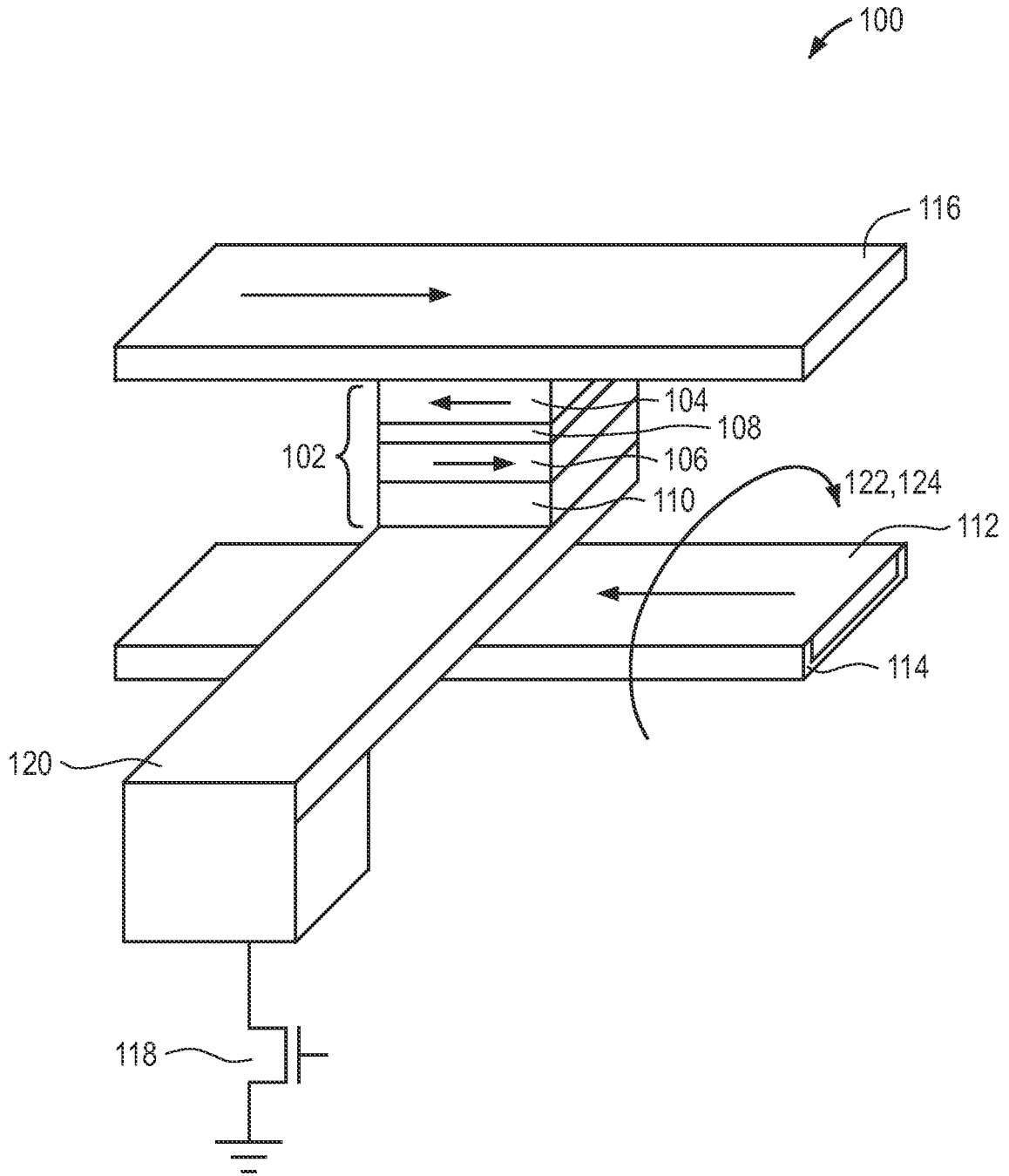

FIG. 1

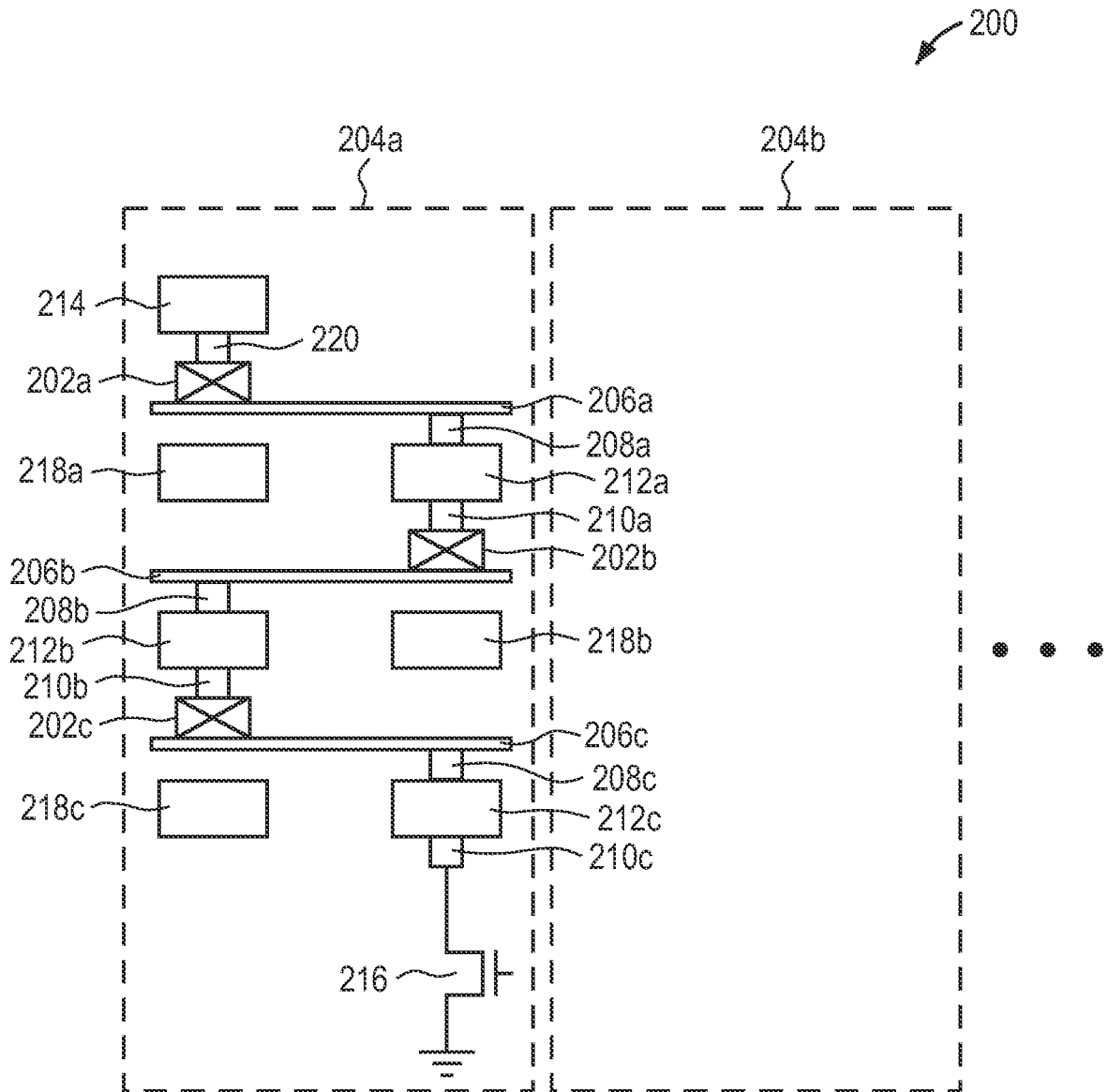

FIG. 2

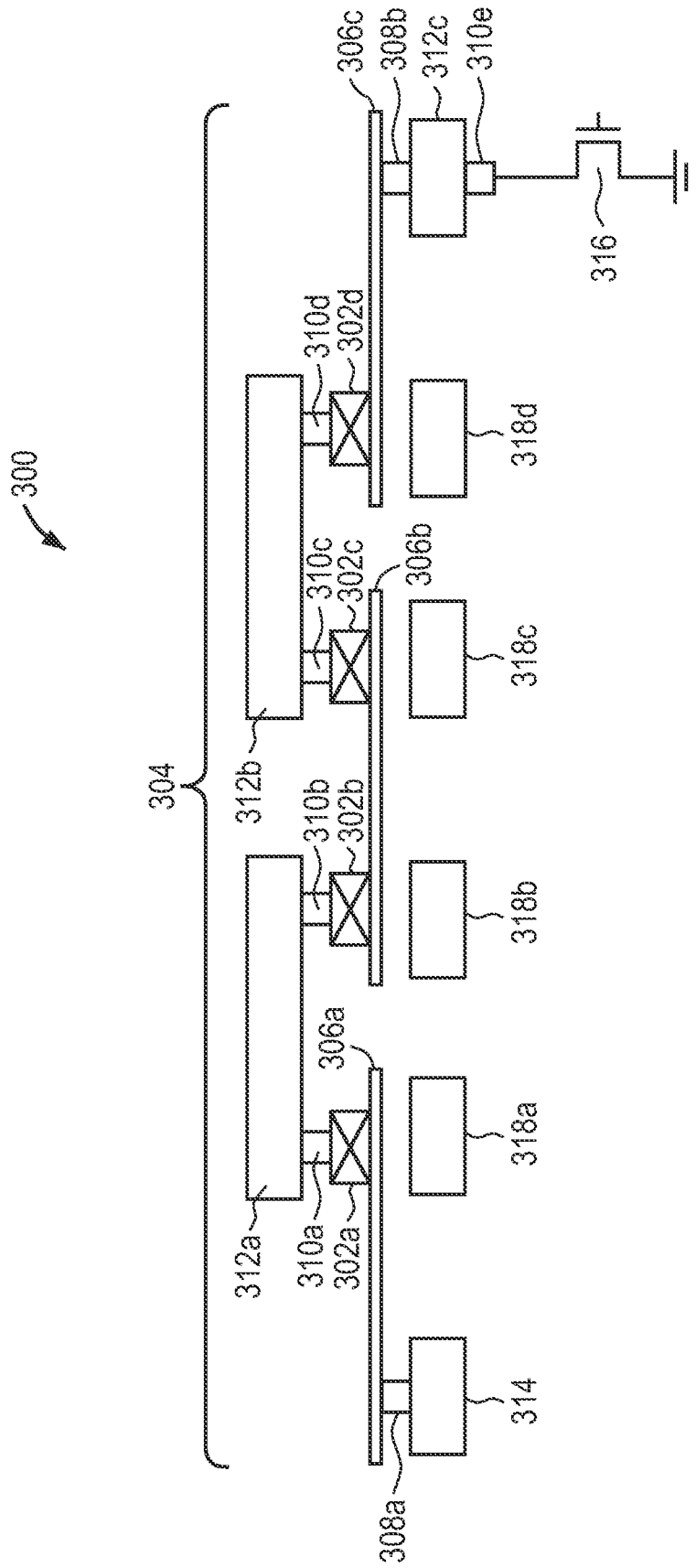

FIG. 3