

(No Model.)

C. L. MEINZER.

GRAIN DRILL.

No. 336,420.

Patented Feb. 16, 1886.

Fig. 1.

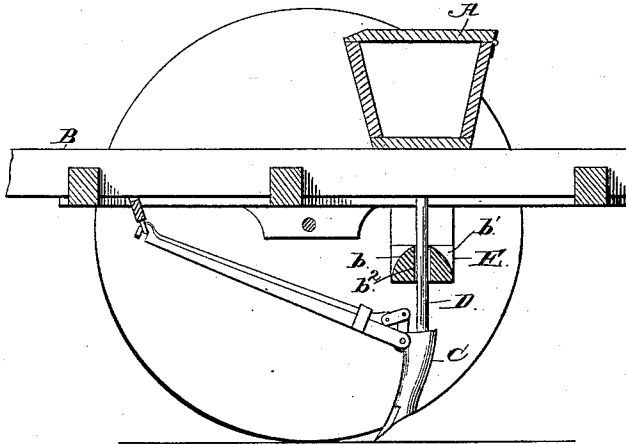

Fig. 2.

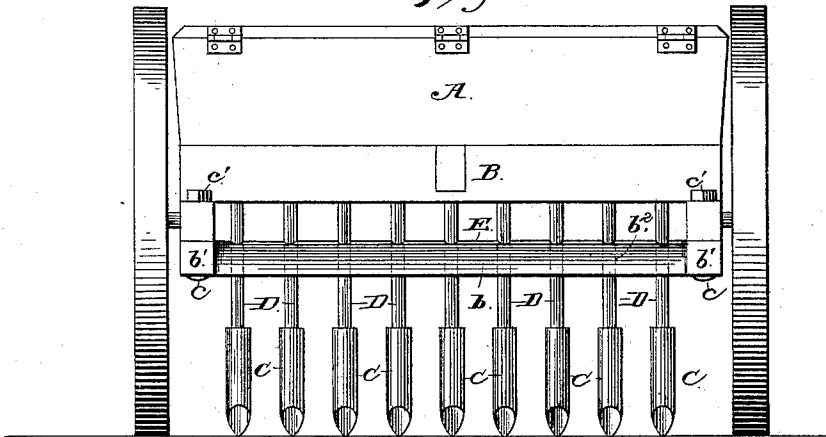

Fig. 3.



WITNESSES

M. E. Fowler

H. Bernhart

INVENTOR

Charles L. Meinzer

By M. Snowles
Attorneys

UNITED STATES PATENT OFFICE.

CHARLES LEWES MEINZER, OF PITT, OHIO.

GRAIN-DRILL.

SPECIFICATION forming part of Letters Patent No. 336,420, dated February 16, 1886.

Application filed October 21, 1885. Serial No. 180,527. (No model.)

To all whom it may concern:

Be it known that I, CHARLES L. MEINZER, a citizen of the United States, residing at Pitt, in the county of Wyandot and State of Ohio, have invented new and useful Improvements in Grain-Drills, of which the following is a specification, reference being had to the accompanying drawings.

My invention has relation to improvements in grain-drills of that class employing adjustable boots and conducting-tubes from the seed-hopper to said boots; and the novelty consists in the peculiar construction, combination, and arrangement of parts, substantially as herein-after fully set forth, and specifically pointed out in the claims.

In drills of the class above described the flexible conducting-tubes from the hopper to the boots are liable to become disengaged from the latter when the machine is in use, particularly when drilling rough ground and on hillsides, or when one of the boots strikes a clod of earth or stone or other obstruction, and the lower ends of said conducting-tubes are liable to become worn and useless in a short time through excessive friction and rubbing between the two surfaces.

My invention has for its objects to provide a device which shall retain the flexible conducting-tubes at all times in engagement with the boots without reference to the class of work being performed by the drill; to provide means for holding said conducting-tubes at all times in a vertical or their proper position, and which shall be easily and readily detached from and secured to the machine-frame.

In the accompanying drawings, Figure 1 is a side elevation of a grain-drill, partly broken away to show the relative arrangement of parts, and having my improved tube-holding device applied thereto. Fig. 2 is a rear elevation thereof, and Fig. 3 is a detail perspective view of the tube holding or retaining bar detached from the machine.

Referring to the drawings, in which like letters of reference indicate corresponding parts in all the figures, A designates the hopper of a grain-drill of ordinary construction; B, the supporting-frame thereof; C, the adjustable boots; D, the flexible conducting-tubes leading from and connected to the hop-

per A and the boots C, and E my improved retaining or holding bar arranged above the boots C and bolted to the frame B, as will be more fully described presently. The cross-bar E preferably has its upper surface rounded or beveled, as at *b*, the ends thereof being left square or rectangular to provide bearing or supporting blocks *b'*, and a series of holes or openings, *b''*, are cut or formed transversely through the same and of a diameter a little larger than the diameters of the conducting-tubes D.

To secure the device in position, the flexible conducting-tubes D are passed through the openings *b''* in the cross-bar E, which is then moved into position so that the blocks or shoulders *b'* thereof bear against the lower faces of the side bars of the main frame B, and through-bolts *c* are then passed through the blocks or shoulders *b'* and the side bars of said frame and receive securing-nuts *c'*, as will be very readily understood.

From the foregoing description, taken in connection with the drawings, it will be observed that by means of the cross or tube-holding bar the conducting-tubes are held in their proper position at all times, no matter what the character of the work being performed by the drill; that the tubes are prevented from movement when the machine is in motion, and are thus kept in proper position in the boots and out of contact with the same at their lower ends, and thus increase the durability of said conducting-tubes by preventing friction and wear between the tubes and boots; that the tubes will be properly held to discharge or conduct the seed when the machine is used on the hillsides and without reference to the speed at which the machine is driven, and that the device can be easily and readily detached and applied to any machine of the class above described.

If desired, a block may be inserted between the bearing-shoulders *b'* of the tube-retaining and guide bar and the drill-frame, to cause the former to be located at a farther distance from the hopper. For drilling zigzag two bars are provided—one to each end of the boots and conducting-tubes—and when the timothy seed sower is in front of the hopper both of said bars may be in one piece and flat. The

means for fastening or securing the bar to the hopper may be varied, as a thumb-nut may be employed to hold the bar adjustably to the frame; or a casting with a set-screw may be substituted.

The holes or openings in the bar are made to correspond in number and distance apart to the number of tubes on the machine and to the width which separates them, and in lieu of the holes or openings brackets or staples may be employed to hold and guide the tubes.

Having thus fully described my invention, what I claim as new, and desire to secure by Letters Patent, is—

1. In a seeding-machine, the combination of the frame, the boots, the conducting-tubes leading from the hopper to said boots, and a guide-bar secured to the frame above the boots and having guides that engage the conducting-tubes to hold them normally in proper

position within the boots, substantially as described.

2. In a seeding-machine, the combination of the frame, the adjustable boots thereof, the flexible conducting-tubes leading from the hopper to said boots, and a guide-bar arranged above the boots and detachably bolted to the frame and having a series of openings, b^2 , through which the flexible conducting-tubes are passed and normally held by said bar in proper position within the boots, substantially as described.

In testimony that I claim the foregoing as my own I have hereto affixed my signature in presence of two witnesses.

CHARLES LEWES MEINZER.

Witnesses:

ISAAC CAHILL,
IDA B. RUHL.