



- (51) International Patent Classification:
G01H 11/08 (2006.01) G01N 29/22 (2006.01)
- (21) International Application Number:
PCT/US2016/048577
- (22) International Filing Date:
25 August 2016 (25.08.2016)
- (25) Filing Language: English
- (26) Publication Language: English
- (30) Priority Data:
62/214,233 4 September 2015 (04.09.2015) US
- (71) Applicant: UT-BATTELLE, LLC [US/US]; One Bethel Valley Road, 4500n, Ms-6258, Oak Ridge, Tennessee 37831-6258 (US).
- (72) Inventor: MCINTYRE, Timothy J.; 208 Lawton Boulevard, Farragut, Tennessee 37934 (US).
- (74) Agent: NELSON, Gregory A.; Fox Rothschild LLP, 997 Lenox Drive, Building 3, Lawrenceville, New Jersey 08648 (US).

- (81) Designated States (unless otherwise indicated, for every kind of national protection available): AE, AG, AL, AM, AO, AT, AU, AZ, BA, BB, BG, BH, BN, BR, BW, BY, BZ, CA, CH, CL, CN, CO, CR, CU, CZ, DE, DK, DM, DO, DZ, EC, EE, EG, ES, FI, GB, GD, GE, GH, GM, GT, HN, HR, HU, ID, IL, IN, IR, IS, JP, KE, KG, KN, KP, KR, KZ, LA, LC, LK, LR, LS, LU, LY, MA, MD, ME, MG, MK, MN, MW, MX, MY, MZ, NA, NG, NI, NO, NZ, OM, PA, PE, PG, PH, PL, PT, QA, RO, RS, RU, RW, SA, SC, SD, SE, SG, SK, SL, SM, ST, SV, SY, TH, TJ, TM, TN, TR, TT, TZ, UA, UG, US, UZ, VC, VN, ZA, ZM, ZW.
- (84) Designated States (unless otherwise indicated, for every kind of regional protection available): ARIPO (BW, GH, GM, KE, LR, LS, MW, MZ, NA, RW, SD, SL, ST, SZ, TZ, UG, ZM, ZW), Eurasian (AM, AZ, BY, KG, KZ, RU, TJ, TM), European (AL, AT, BE, BG, CH, CY, CZ, DE, DK, EE, ES, FI, FR, GB, GR, HR, HU, IE, IS, IT, LT, LU, LV, MC, MK, MT, NL, NO, PL, PT, RO, RS, SE, SI, SK, SM, TR), OAPI (BF, BJ, CF, CG, CI, CM, GA, GN, GQ, GW, KM, ML, MR, NE, SN, TD, TG).

Published:
— with international search report (Art. 21(3))



WO 2017/040174 A1

(54) Title: DIRECT WRITE SENSORS

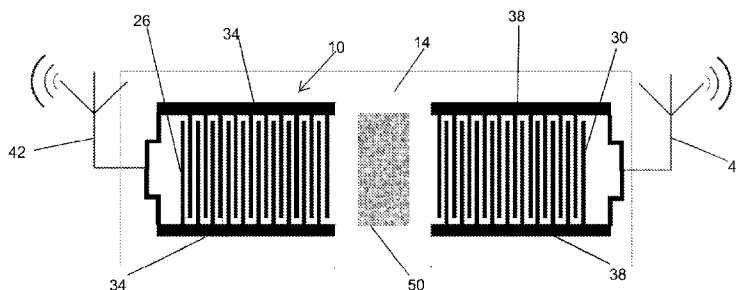

FIG. 2

(57) Abstract: A method of making an acoustic wave sensor includes the steps of providing a piezoelectric substrate layer and printing on the substrate layer a sensor layer comprising a first interdigitated acoustic wave transducer, a sensing film, and positioned on an opposing side of the sensing film from the first interdigitated acoustic wave transducer at least one selected from the group consisting of a second interdigitated acoustic wave transducer and a Bragg reflector. An insulation layer can be printed. An antenna can be printed in an antenna layer, and the insulation layer can be interposed between the antenna layer and the sensor layer. An electrical connection can be printed between the antenna and the first interdigitated acoustic wave transducer. An acoustic wave sensor is also disclosed.

DIRECT WRITE SENSORS

STATEMENT REGARDING FEDERALLY SPONSORED RESEARCH

[1] This invention was made with government support under contract No. DE-AC05-00OR22725 awarded by the US Department of Energy. The government has certain rights in this invention.

CROSS-REFERENCE TO RELATED APPLICATION

[2] This Application claims priority to U.S. Patent Application No. 62/214,233, filed September 4, 2015, entitled "Direct Write Sensors", the entirety of which is incorporated herein by reference.

FIELD OF THE INVENTION

[3] This invention relates generally to acoustic wave sensors, and more particularly to methods and designs for making acoustic wave sensors.

BACKGROUND OF THE INVENTION

[4] Bulk acoustic wave (BAW) and surface acoustic wave (SAW) devices have been fabricated for decades using traditional semiconductor integrated circuit methods. These methods are mature and optimized to produce >1 billion high fidelity, matched filters for RF and microwave communications such as cell phones, walkie-talkies, and other devices. However, relatively sophisticated and expensive equipment is required to produce these devices.

[5] High performance acoustic wave structures have recently been exploited for sensor applications. Acoustic wave structures have been demonstrated to perform as temperature, strain and hydrogen sensing

devices, employing traditional photo-lithography for device fabrication. Photo-lithography is time consuming and comparatively expensive, and accordingly new methodologies for manufacturing such sensors are necessary.

SUMMARY OF THE INVENTION

[6] A method of making an acoustic wave sensor includes the steps of providing a piezoelectric substrate layer and printing on the substrate layer a sensor layer comprising a first interdigitated acoustic wave transducer, and at least one other feature selected from the group consisting of a sensing film, an interdigitated acoustic wave transducer, and a Bragg reflector. A second interdigitated acoustic wave transducer or one or more Bragg reflectors can be positioned on an opposing side of the sensing film, if present, from the first interdigitated acoustic wave transducer. An insulation layer can be printed. An antenna can be printed in an antenna layer, and the insulation layer can be interposed between the antenna layer and the sensor layer. An electrical connection can be printed between the antenna and the first interdigitated acoustic wave transducer. The printing method can be performed by aerosol jet direct digital printing.

[7] The acoustic wave sensor can be a bulk acoustic wave sensor. The Q factor of the bulk acoustic wave sensor can be greater than 1000.

[8] The piezoelectric substrate can be provided as a film and moved roll to roll during the printing process.

[9] The method can further include the step of controlling the movement of the aerosol jet thorough a control system and at least one processor.

[10] A plurality of acoustic wave sensors can be printed on the piezoelectric substrate, and the method can further include the step of separating the substrate and the acoustic wave sensors into individual acoustic wave sensors.

[11] The sensing film can include a hydrophilic material. The sensing film can include palladium. The sensing film can include graphene. The sensing film can include a carbon nanotube array. The sensor can have a maximum dimension of less than 2mm^2 .

[12] The sensor layer and antenna layer can be printed on opposing sides of the piezoelectric substrate layer. At least a portion of the sensor layer and the antenna layer can be printed simultaneously.

[13] An acoustic wave sensor can include a piezoelectric substrate layer and a sensor layer joined to the substrate layer and comprising a first interdigitated acoustic wave transducer, and at least one other feature selected from the group consisting of a sensing film, an interdigitated acoustic wave transducer, and a Bragg reflector. A second interdigitated acoustic wave transducer or one or more Bragg reflectors can be positioned on an opposing side of the sensing film, if present, from the first interdigitated acoustic wave transducer. All of the interdigitated acoustic wave transducers and Bragg reflector can be aerosol jet printed.

[14] An antenna layer can be provided and an insulation layer can be interposed between the antenna layer and the sensor layer, and the insulation layer and antenna layer can be aerosol jet printed. At least one of the sensor layer and antenna layer can include a dielectric matrix material. The sensor layer and the antenna layer can be printed on opposing sides of the piezoelectric substrate layer.

BRIEF DESCRIPTION OF THE DRAWINGS

[15] There are shown in the drawings embodiments that are presently preferred it being understood that the invention is not limited to the arrangements and instrumentalities shown, wherein:

[16] Fig. 1 is a schematic diagram of a surface acoustic wave device according to the invention.

[17] Fig. 2 is a schematic diagram of a surface acoustic wave device functionalized by a chemical specific film.

[18] Fig. 3 is a schematic diagram of aerosol jet printing of surface acoustic wave devices on a piezoelectric wafer.

[19] Fig. 4 is a schematic diagram of multi-head printing of surface acoustic wave devices.

[20] Fig. 5 is a schematic diagram of multi-head printing on both top and bottom surfaces of moving media.

[21] Fig. 6 is a schematic diagram illustrating pulsed thermal processing of printed surface acoustic wave structures.

[22] Fig. 7A is a schematic diagram of standard aerosol jet printing and Fig. 7B is a schematic diagram of aerosol jet printing augmented by electrostatic/electromagnetic focusing.

[23] Fig. 8 is a perspective schematic view of a surface acoustic wave device.

[24] Fig. 9 is a cross-section of the surface acoustic wave device.

[25] Fig. 10 is a perspective schematic view of a surface acoustic wave device with functionalizing film.

[26] Fig. 11 is a cross-section.

[27] Fig. 12 is a schematic cross-section of a surface acoustic wave device with printed fractal antenna.

[28] Fig. 13 is a bottom view.

[29] Fig. 14 is a schematic cross-section of the surface acoustic wave device with a printed spiral antenna.

[30] Fig. 15 is a bottom view.

[31] Fig. 16 is a schematic cross-section of a bulk acoustic wave device showing an acoustic wave propagating through the piezoelectric substrate, and with a functionalizing film on top of device.

[32] Fig. 17 is a schematic cross-section of a multi-layer bulk acoustic wave device and a string of reflected signals.

[33] Fig. 18 is a schematic cross-section of a variable layer thickness bulk acoustic wave device providing both frequency and time diversity in reflected signals.

[34] Fig. 19 is a schematic diagram of an interdigitated transducer launching an acoustic wave.

[35] Fig. 20 is a schematic diagram of a Bragg reflector returning an acoustic signal to the interdigitated transducer.

[36] Fig. 21 is a schematic diagram of an interdigitated transducer and Bragg reflector and launched acoustic wave and reflected acoustic wave signal.

[37] Fig. 22 is a schematic diagram and photograph of corresponding printed elements in a Bragg reflector.

[38] Fig. 23 is a photograph of printed interdigitated transducer electrodes.

[39] Fig. 24 is a schematic diagram of a dual channel surface acoustic wave device.

[40] Fig. 25 is a schematic cross-section of a dual channel surface acoustic wave device showing antenna connections.

[41] Fig. 26 is a schematic diagram of a dual channel surface acoustic wave device functionalized by hydrogel for moisture sensing.

[42] Fig. 27 is a schematic diagram of a dual channel surface acoustic wave device functionalized by a Palladium film for hydrogen sensing.

[43] Fig. 28 is a schematic diagram of a dual channel surface acoustic wave device functionalized by graphene nanostructures for methane detection.

[44] Fig. 29 is a schematic diagram of the dual channel surface acoustic wave device functionalized by carbon nanotubes for CO₂ detection.

[45] Fig. 30 is a photograph of printed dual channel surface acoustic wave devices.

[46] Fig. 31 is a schematic diagram illustrating an array of surface acoustic wave devices printed simultaneously and sequentially.

[47] Fig. 32 is a plot of sheet resistance (ohms/Sq) versus annealing temperature (°C) for printed structures by an ultrasonic atomizer.

[48] Fig. 33 is a plot of sheet resistance (ohms/Sq) versus annealing temperature (°C) for printed structures by a pneumatic atomizer.

[49] Fig. 34 is a photograph of a 10 μm line printed on a piezoelectric polymer (PV DF) substrate with 50 nm silver particles in a liquid suspension.

[50] Fig. 35 is a schematic diagram of an ultrasonic atomizer print head.

[51] Fig. 36 is a schematic diagram of a pneumatic atomizer print head.

DETAILED DESCRIPTION OF THE INVENTION

[52] A method of making an acoustic wave sensor includes the steps of providing a piezoelectric substrate layer and printing on the substrate layer a sensor layer comprising a first interdigitated acoustic wave transducer, and at least one other feature selected from the group consisting of a sensing film, an interdigitated acoustic wave transducer, and a Bragg reflector. A second interdigitated acoustic wave transducer or one or more Bragg reflectors can be positioned on an opposing side of the sensing film, if present, from the first interdigitated acoustic wave transducer. An insulation layer can be printed. An antenna can be printed in an antenna layer, and the insulation layer can be interposed between the antenna layer and the sensor layer. The antenna can alternatively be provided separately, and printed or produced by other means. An electrical connection can be printed between the antenna and the first interdigitated acoustic wave transducer. The printing method can be performed by aerosol jet direct digital printing.

[53] The movement of the aerosol jet thorough a control system and at least one processor. Any suitable control mechanism and processor or controller is possible.

[54] A plurality of acoustic wave sensors can be printed on the piezoelectric substrate, and the method can further include the step of separating the

substrate and the acoustic wave sensors into individual acoustic wave sensors. The individual sensors can be cut by any suitable device and packaged as individual sensors or groups of sensors.

[55] The sensing film can be any suitable material. The sensing film can for example include a hydrophilic material. The sensing film can include palladium. The sensing film can include graphene. The sensing film can include a carbon nanotube array. The sensor can have a maximum dimension of less than 2mm^2 . The acoustic wave sensor can be printed without a sensor film to measure temperature, because the piezoelectric material alone can be temperature sensitive in the desired temperature range.

[56] The sensor layer and antenna layer can be printed on opposing sides of the piezoelectric substrate layer. The antenna can connect to more than one sensor. Sensors can be printed on both sides of the piezoelectric substrate layer. Vias can be created through the substrate and suitable electrical connections can be provided through the vias by any suitable method, including aerosol jet printing. At least a portion of the sensor layer and the antenna layer can be printed simultaneously.

[57] An acoustic wave sensor can include a piezoelectric substrate layer and a sensor layer joined to the substrate layer and comprising a first interdigitated acoustic wave transducer, and at least one other feature selected from the group consisting of a sensing film, an interdigitated acoustic wave transducer, and a Bragg reflector. A second interdigitated acoustic wave transducer or

one or more Bragg reflectors can be positioned on an opposing side of the sensing film, if present, from the first interdigitated acoustic wave transducer. All of the interdigitated acoustic wave transducers and Bragg reflectors can be aerosol jet printed.

[58] An antenna layer can be provided and an insulation layer can be interposed between the antenna layer and the sensor layer, and the insulation layer and antenna layer can be aerosol jet printed. At least one of the sensor layer and antenna layer can include a dielectric matrix material. The sensor layer and the antenna layer can be printed on opposing sides of the piezoelectric substrate layer. Many antenna designs can be utilized including, without limitation, dipole antennas, gap loaded Archimedean spiral antennas, fractal antennas, and patch antenna arrays.

[59] Fig. 1 is a schematic diagram of a surface acoustic wave device 10 according to the invention. The device 10 includes a piezoelectric substrate 14. An interdigitated transducer 18 has interdigitated transducer lines 26 and contacts 34 which connect to antenna 42. An interdigitated transducer 22 has interdigitated transducer lines 30 and contacts 38 which connect to antenna 46.

[60] Fig. 2 is a schematic diagram of the surface acoustic wave device 10 functionalized by a chemical specific film 50. The film 50 can be printed by aerosol jet printing. The film 50 can also be applied by other methods.

[61] Fig. 3 is a schematic diagram of aerosol jet printing of surface acoustic wave devices on a piezoelectric wafer. An aerosol jet print head 54 includes an outer housing 58 and neck 62. An inner sheath 66 defines an annular space 74 for the flow of sheath gas that serves to focus and direct the aerosol 74 into a fine jet 78. Movement of the print head 54 can be controlled by a processor and control mechanisms to direct the jet 78 so as to create sensors 82 on the substrate 86. The substrate 86 can be in the form of a wafer and can be moved in the direction of arrows 90 and 94 to permit the printing of a multitude of sensors on the same wafer.

[62] Fig. 4 is a schematic diagram of multi-head printing of surface acoustic wave devices. This is shown schematically by print head 54A which moves according to direction arrow 104, and print head 54B which can move in the same or a different direction as shown by arrow 108. Accordingly multiple sensors 100 can be printed rapidly and in some cases simultaneously onto substrate 98.

[63] Fig. 5 is a schematic diagram of multi-head printing on both top and bottom surfaces of moving media. Multiple print heads such as print heads 54A and 54B can be provided to print sensors 120 onto substrate 116. The substrate 116 can be in the form of a film which moves from roll 124 to roll 128 in a roll-to-roll printing process. A print head 112 can be provided on an underside of the substrate 116 such that sensors can be printed simultaneously on both sides of the substrate 116, or components of sensors can be printed on opposing sides of the substrate 116, such as sensor layers

on one side and antenna layers on the opposing side. The substrate 116 can be moved in the direction of arrow 132 such that a succession of sensors 120 can be rapidly printed. The process can also be configured to move vertically from roll to roll.

[64] Fig. 6 is a schematic diagram illustrating pulsed thermal processing devices 136 and 144 emitting high intensity radiation 140 and 148 respectively to effect curing of the sensor layers on the substrate 116.

[65] Fig. 7 is a schematic diagram of (Fig. 7A) of a standard aerosol jet print head and (Fig. 7 B) aerosol jet printing augmented by electrostatic/electromagnetic focusing. The focusing can be by any suitable structure such as electromagnets 152, 156 which focus the jet 78 to a very fine micro jet 160 enabling printing of features less than 10 μm in extent.

[66] Fig. 8 is a perspective schematic view of a surface acoustic wave device 180 having interdigitated transducers 172 and 176 printed on piezoelectric substrate 168. Fig. 9 is a cross-section of the surface acoustic wave device 180.

[67] Fig. 10 is a perspective schematic view of the surface acoustic wave device 168 having substrate 180 with interdigitated transducers 172 and 176, and with functionalizing film 184. The functionalizing film 184 can also be applied by aerosol jet printing. As seen in Fig. 11, the features can be printed in a single pass of the substrate 180 past the print heads.

[68] Figs. 12-13 are a schematic cross-section and bottom view of a surface acoustic wave device 190 in which a substrate 194 has interdigitated transducers 198 and 202 printed on a 1st side 206. A 2nd side 210 of the substrate 194 has printed thereon antennas 214 and 218. Multiple sensors can be connected to the same antenna. The antenna 214 can have contact 222 and the antenna 218 can have contact 226 which contacts can be printed with the aerosol jet printer on a bottom side 210 of the substrate 194.

[69] Figs. 14-15 are a schematic cross-section and bottom view of the surface acoustic wave device 230 with a having a substrate 234. Interdigitated transducers 238 and 240, and sensor film 244 can be printed on a 1st side 248 of the substrate 234. On a 2nd side 252 of the substrate 234 can be printed spiral antennas 256 and 260. Many different antenna designs can be printed.

[70] Fig. 16 is a schematic cross-section of a bulk acoustic wave device 264 having a substrate 268. An interdigitated transducer 272 is provided on a 1st side 276 of substrate 268. An interdigitated transducer 280 is provided on 2nd side 284 of substrate 268. A functionalizing film 290 is shown on top of the 1st interdigitated transducer 272. An acoustic wave 294 is shown propagating through the piezoelectric substrate 268. The interdigitated transducers 272 and 280, as well as functionalizing film 290 can be printed on the substrate 268 by aerosol jet printing. The Q factor of the bulk acoustic wave sensor can be greater than 1000.

[71] Fig. 17 is a schematic cross-section of a multi-layer bulk acoustic wave device 300 having a substrate 304 comprised of several layers 304 A-E. A 1st interdigitated transducer 308 can be provided on a 1st side 312 of the substrate 304. A 2nd interdigitated transducer 316 can be provided on 2nd side 320 of substrate 304. A functionalizing film 324 can be provided on top of the 1st interdigitated transducer 308. The acoustic waves indicated by arrows 328 A-E can produce a string of reflected signals. All features of the device 300 can be printed on the substrate 304 by aerosol jet printing.

[72] Fig. 18 is a schematic cross-section of a variable layer thickness bulk acoustic wave device 340 having a substrate 344. The substrate 344 is comprised of layers 348, 352, and 356 of variable layer thickness. A 1st interdigitated transducer 360 is provided on a surface 364 of the substrate 344. A 2nd interdigitated transducer 368 can be provided on a side 372 of the substrate 344. A functionalizing film 376 can be provided on top of the 1st interdigitated transducer 360. Acoustic signals 380, 384, 388 will be reflected by the variable thickness layers according to the wavelengths of the signal and the properties and thickness of the layers 348, 352, and 356. The interdigitated transducers 360 and 368 and functionalizing film 376 can be printed by aerosol jet printing. The variable thickness bulk acoustic wave device 340 provides both frequency and time diversity in reflected signals.

[73] Fig. 19 is a schematic diagram of an interdigitated transducer 392 having contacts 396 and 400 and interdigitated lines 404. An acoustic wave schematically indicated as 408 is propagated in the direction shown by arrow

412. Fig. 20 is a schematic diagram of a Bragg reflector 416 having ends 420 and reflecting layers 424. The Bragg reflector 416 selectively reflects signal 428 in the direction of arrow 432. As shown in Fig. 21, the acoustic signal 408 is emitted and returned to the interdigitated transducer 392 as reflected signal 428. As shown in Fig. 22 the Bragg reflector 416 can be printed on substrate 430 by aerosol jet printing. There is shown in Fig. 23 printed electrodes 434 and 438 of a dual channel interdigitated transducer printed on substrate 442. A series of Bragg reflectors can also be used to create an identification code. Each Bragg reflector has a unique geometry (different line width and spacing) causing a group of returned signals each having a different frequency.

[74] Figs. 24-25 are a schematic diagram and cross-section of a dual channel surface acoustic wave device 450. The device 450 includes a 1st electrode 454 having branches 458 and 462. A 2nd electrode 466 has a terminus 470. Interdigitated transducer lines 474 and 478 are positioned between the 1st branch 458 and the terminus 470 and the 2nd branch 462 and the terminus 470. An antenna 490 can connect across the electrodes 454 and 466 to impart a signal. The antenna 490 can be connected by line 494 to electrode 466, and by line 498 to electrode 454.

[75] Fig. 26 is a schematic diagram of the dual channel surface acoustic wave device 450 functionalized by hydrogel 502 for moisture sensing. Fig. 27 is a schematic diagram of the dual channel surface acoustic wave device 450 functionalized by a Palladium film 506 for hydrogen sensing. Fig. 28 is a schematic diagram of the dual channel surface acoustic wave device 450

functionalized by graphene nanostructures 510 for methane detection. Fig. 29 is a schematic diagram of the dual channel surface acoustic wave device functionalized by carbon nanotubes 514 for CO₂ detection. These films can be printed by aerosol jet printing or fabricated by other means.

Functionalization can also be achieved with organic compounds called amines. Amines are derived from ammonia and can be tailored for CO₂ detection, for example. The amine is also printed by aerosol jet methods.

[76] Fig. 30 is a photograph of printed dual channel surface acoustic wave devices 518 printed according to the invention. Fig. 31 is a schematic diagram illustrating how an array of surface acoustic wave devices 522 can be printed simultaneously and sequentially on a single substrate. Employing a printing process that implements a 2mm² device with 2mm pitch, results in ~2,000 devices/wafer. A 50% decrease in sensor size more than triples the number of sensors per wafer. Multiple acoustic wave sensors as in Fig. 30 can be provided for sensing different phenomena, and can be printed and combined to determine conditions or properties not able to be determined with a single acoustic wave sensor (such as to measure temperature and humidity in combination to determine dew point). An array of sensors such as shown in Fig. 31 can be used to measure the same properties, and the results combined to create a statistical result with improved accuracy over the result from a single sensor.

[77] Fig. 32 is a plot of sheet resistance (ohms/Sq) versus annealing temperature (°C) for structures printed by an ultrasonic atomizer. The plot

shows that sheet resistance generally decreases with increasing annealing temperature. Fig. 33 is a plot of sheet resistance (ohms/Sq) versus annealing temperature ($^{\circ}\text{C}$) for structures printed by a pneumatic atomizer. The decrease in sheet resistance with annealing is not as pronounced for the pneumatic atomizer as for the ultrasonic atomizer.

[78] Fig. 34 is a photograph of a 10 μm line printed with 50 nm silver particles suspended in alcohol on a piezoelectric polymer (PVDF) substrate. This figure illustrates the very fine features that can be printed for sensors according to the invention.

[79] Fig. 35 is a schematic diagram of an ultrasonic atomizer print head assembly 520. The print head 520 includes an ultrasonic transducer 524 for applying energy to the ink bath 528. This creates droplets 522 which mix with gas from gas inlet 544 in chamber 536 and provide an aerosol in conduit 540 which exits at outlet 548 to the print head. The transducer 524 produces high-frequency pressure waves causing the ink or other liquid source material to be atomized. The atomized droplets are then entrained in the gas stream and deposited on the substrate. This device can be used for materials with viscosity in the range of 1 - 5 cP and particulate suspensions of 50 nm or less.

[80] Fig. 36 is a schematic diagram of a pneumatic atomizer print head 560. Gas enters the device through gas inlet 564 and mixes with in bath 568. The aerosol so created exits at outlet 572 to the print nozzle. An exhaust 576 can also be provided. The pneumatic atomizer uses high-velocity gas stream to

shear liquid ink into small droplets (1 to 5 μm). Compressed gas is expanded through the atomizer nozzle, producing a high-velocity jet. Larger droplets impact the walls, returning to the reservoir. Smaller droplets remain suspended for deposition. The pneumatic atomizer can be used for inks, pastes, or other materials with viscosity in the range of 1 to 1000 cP and particulate suspensions < 500 nm in size.

[81] The BAW/SAW sensors of the invention can be fabricated by suitable aerosol jet equipment, such as can be obtained from Optomec, Inc. (Albuquerque, NM). Other possible fabrication methods including ink jet printing, screen printing, syringe printing, plasma spray printing, and myriad fused deposition printing methods including laser and electron beam melting, are capable of printing structures that fall into a subset of aerosol jet capabilities. Aerosol jet is a highly versatile additive manufacturing tool capable of efficiently depositing metals, semi-conductors, insulators, polymers and even biological materials in precise miniature patterns or larger structures depending upon the system configuration.

[82] SAW devices rely on precise feature size printing in order to function in recognized ISM communication frequency bands compatible with many existing process control and automation systems. The invention has achieved some of the smallest aerosol jet sensor structures to date. Both a dual channel SAW device and a Bragg reflector having $\sim 6\mu\text{m}$ features have been produced. This feature size produces an operating frequency range of $\sim 125\text{-}175\text{MHz}$ in the resulting SAW device. Controlling the operating frequency of

acoustic wave sensors is important for two reasons: a) the operating frequency largely determines the operational communication distance between the passive sensor and the interrogator; and b) tailoring the frequency response provides each sensor with a unique identity.

[83] Fabricating BAW sensors also requires precise deposition control. BAW devices rely on precise control of device layer thickness. Aerosol jet provides ~10 nanometer layer thickness printing control. The performance of the device, commonly represented by the Q-factor, is also highly dependent on the device geometry. Aerosol jet printed BAW devices can achieve $Q_f > 1,000$, enabling detection limits as small as 1 part in 10^9 (1 part/billion or 1 ppb). Similarly, SAW devices have also demonstrated sub-ppm detection limits.

[84] The invention is capable of producing sensors with many different modes of sensing including: physical sensors, chemical sensors, biological sensors, location and tracking sensors, and tamper resistant seals. Possible sensor modalities include, without limitation physical sensors for temperature, strain, pressure, corrosion. Chemical sensors are used to measure humidity/moisture, CO_2 , CH_4 , HF, VOCs, H_2 , and the like. Electronic sensors measure current flow, voltage and charge. Biological sensors test for food spoilage, bacterial and fungal agents, blood sugar level, and other biometric factors. Location and tracking sensors and tamper resistant seals are also becoming more common. Sensing applications include physical sensing for energy control, condition monitoring, and presence detection. Electronic

sensing is performed for grid monitoring and surveillance. Chemical sensing is used for pipeline monitoring, leak/plume detection, and accident response. Multiple sensor modalities can easily be combined to produce a unique signature or finger print. Other applications are possible.

[85] BAW and SAW sensor functionality is realized by measuring the change in the acoustic wave propagation velocity within the device substrate. The following relationship describes this phenomenon by relating the interrogator operating frequency to the acoustic propagation velocity divided by the acoustic wavelength. The physical feature size of the device (BAW – layer thickness and SAW – spatial feature size and pitch) largely determines the operating parameters.

$$\mathbf{[86] \quad v=c/\lambda \quad (1)}$$

[87] In equation (1), v represents the electromagnetic interrogation frequency as described above. The invention is capable of printing SAW devices with 6-20 μ m feature size and operational frequencies ranging from 37.5-175MHz. The device propagation velocity represented by c in equation (1) is the acoustic propagation velocity within the device substrate, not the speed of light. The acoustic velocity can range from 1,500 to nearly 4,500 m/s, depending upon substrate material selection. The λ represents the acoustic wavelength of the device determined by layer thickness or surface features for BAW and SAW devices respectively. For SAW devices being printed currently, the Bragg reflectors and IDT include \sim 10 μ m line width and

pitch. This critical feature size is generally interpreted as $\lambda/4$, the quarter-wave coupling wavelength from antenna theory.

$$[88] \quad v = \frac{c}{\left(\lambda/4\right)} = \frac{4,000m/s}{\left(10\mu m/4\right)} = \sim 75MHz \quad (2)$$

[89] In order to create an acoustic sensor, it is necessary to couple to the sensor substrate and modify the acoustic propagation velocity. There are two principle ways in which acoustic velocity is altered: a) mass loading – the substrate gains additional inertia through increased mass loading causing a mechanical impedance to the acoustic wave; and b) strain induced modification of the substrate elastic modulus – the acoustoelectric effect. Both phenomena result in a change of amplitude, phase, frequency or a time delay - the returned signal arrives later in time proportional to the changed mass or strain.

[90] Surface acoustic wave devices require their substrate to be a ferroelectric material. More specifically, piezoelectric substrate materials such as lead-zirconate-titanate (PZT), lithium niobate, or quartz produce the greatest response or conversion efficiency. Polymeric substrates, such as polyvinylidene fluoride (PVDF), also exhibits ferroelectric properties, allowing acoustic devices to be printed upon flexible substrates. Other materials are possible.

[91] Piezoelectric materials exhibit temperature dependent response, hence a SAW device functions as a temperature sensor without further functionalization. To sense other physical variables, the SAW device is functionalized by mechanical means. For instance, a very sensitive pressure sensor is created by functionalizing the SAW device by making the substrate a flexible element or diaphragm. This flexing is caused by changing pressure, creating a changing strain in the substrate that is detected as an acoustic velocity shift in the SAW device.

[92] Sensing chemical or biological variables requires functionalization in a different manner. Humidity sensing is a relatively simple example of functionalization via mass loading. Polymethylmethacrylate (PMMA), is a reversible hydrophilic material that is readily printed by AJ methods. Hydrophilic aerogels can also be printed. Fig. 26 illustrates a SAW humidity sensor architecture. The hydrophilic region is deposited into one of the SAW device channels. An acoustic velocity change occurs as moisture loading changes. As the film increases in mass, the acoustic velocity decreases, and vice versa.

[93] Many film treatments are possible to functionalize the SAW device. Phase separated glass and metal oxide structures provide a scaffold having extremely high surface area. These high surface area structures are then functionalized by creating chemically specific absorption sites, such as, palladium nanoparticles for hydrogen sensing. A nanostructured spinodally phase separated ultra-porous silica film can be deposited on lithium niobate.

[94] The sensor design and functionalization methods can be utilized with a single aerosol jet deposition head or multiple heads. The sensor designs can be scaled-up for roll-to-roll processing by employing a multi-head approach. Aerosol jet deposition can be performed with a parallel head array, but additional head arrays can also be performing additional fabrication steps down stream. A variety of materials can be printed, including conductors, insulators, semi-conductors, dielectrics, and biological materials. Feature sizes less than $\sim 10\mu\text{m}$ and with no real upper limit are possible. The method is compatible with rigid and flexible substrates. The integration of sensors, antennas, and electronics is possible, with a wide range of operating communications frequencies

[95] Key controls include ink selection (viscosity, conductor, insulator and dielectric), substrate selection (material, thickness, wafer or polymer film, deposition rate, nozzle size, atomization carrier gas pressure and flow rate, sheath gas pressure and flow rate, exhaust gas pressure and flow rate, scanning speed and thermal management.

[96] Example

[97] Surface acoustic wave (SAW) sensors were developed using aerosol jet direct digital printing, employing an Optomec AJ200 system. Single channel and dual channel sensors were demonstrated. Sensor modalities include temperature, humidity and CO_2 . Volatile organic compound (VOC) sensors and other physical sensors such as pressure, corrosion, current and voltage

are possible. The invention allows printing features as small as 5 microns, and feature size to 1 micron or less are possible. In order to fabricate these sensors, several parameters must be controlled. A 100 micron nozzle, combined with 25 ccm aerosol flow rate from an ultrasonic atomizer (UA) was utilized. The UA was set to 0.3mA, with a nitrogen sheath gas flow rate of 22ccm. The processing speed was 1mm/sec, depositing Clariant silver colloid 25 ink with on a lithium niobate substrate. The total print time was 2 minutes.

[98] The ease and low cost of manufacture of sensors created by the invention present the possibility of disposable sensors. Disposable sensors create a paradigm shift in measurement, control, monitoring, etc. by opening up new methods and approaches. For example, sensors embedded into products during manufacturing, sensors that are embedded into the manufacturing devices/equipment for intimate process monitoring, and sensors that flow-through the manufacturing process on test articles or the actual product itself, can be used to characterize process conditions in situ. Gaining intimate knowledge of manufacturing process conditions has never been done in this way and could lead to significant efficiency gains. Further, having process knowledge, item-by-item has also never been achieved and could be exploited for efficiency gains. For example, many thousand sheets of drywall are manufactured on a daily basis. The condition of the sheet versus the process could be measured providing pinpoint information of actual product condition, versus global process information. Disposable RF/SAW sensors could be applied to each sheet of drywall, monitoring in real-time, the

temperature and moisture content of the sheet. Process conditions, such as oven temperature, residence time, etc. are then controlled in response to optimum product conditions instead of being controlled to a global fixed point.

[99] There are many advantages of aerosol jet printing versus inkjet and screen printing. There is a wider possible material range (metals, alloys, resistor paste, dielectrics, polymers, adhesives). Most materials are standard off-the-shelf. There is no customization that is required. Significantly higher metal loadings are possible, as much as 50%-70 weight percent for high resolution printing. There is a 10 times smaller nano-particle droplet size to produce finer features. There is 20-30 times higher yield than inkjet per nozzle. There are higher volumetric rates and metal loading. There is superior throughput nozzle with higher material loading per droplet. There is 5 times the distance above substrate enables conformal printing on non-planar surfaces. There are much finer feature sizes (10 μm) and tighter pitch (20 μm) pitch. There is better edge definition.

[100] There are many advantages of aerosol jet printing versus screen printing. Noncontact printing eliminates breakage of substrates. Noncontact process enables conformal printing on non-planar substrates. The aerosol jet process is easier to implement changes, and there is no hard tooling. Thinner layer deposits reduced material waste. Much finer feature size (10 μm) and tighter pitch (20 μm) are possible.

[101] Direct printing of conductive patterns eliminates the use of toxic chemicals and saves costs. Nano silver conductive inks allow direct printing of conductive patterns for electronic devices on any surface. Hazardous chemical metallization processes are replaced by water-based ink containing metal particles to form the electronic pattern. Nano-sized silver particles can be cured at low temperatures to create an electric conductor almost as conductive as a pure silver wire.

[102] The invention is capable of taking alternative forms without departing from the spirit or essential attributes thereof, and accordingly reference should be made to the following claims to determine the scope of the invention.

CLAIMS

We claim:

1. A method of making an acoustic wave sensor, comprising the steps of:
 - providing a piezoelectric substrate layer;
 - printing on the substrate layer a sensor layer comprising a first interdigitated acoustic wave transducer, and at least one other feature selected from the group consisting of a sensing film, an interdigitated acoustic wave transducer, and a Bragg reflector.

2. The method of claim 1, comprising printing a sensing film, and printing on an opposing side of the sensing film from the first interdigitated acoustic wave transducer at least one selected from the group consisting of a second interdigitated acoustic wave transducer and a Bragg reflector.

3. The method of claim 1, comprising the steps of:
 - printing an insulation layer;
 - printing an antenna in an antenna layer, wherein the insulation layer is interposed between the antenna layer and the sensor layer; and,
 - printing an electrical connection between the antenna and the first interdigitated acoustic wave transducer.

4. The method of claim 1, wherein the printing is by aerosol jet direct digital printing.

5. The method of claim 1, wherein the acoustic wave sensor is a bulk acoustic wave sensor.
6. The method of claim 5, wherein the Q factor of the bulk acoustic wave sensor is greater than 1000.
7. The method of claim 1, wherein the piezoelectric substrate is provided as a film and is moved roll to roll during the printing process.
8. The method of claim 1, further comprising the step of controlling the movement of the aerosol jet thorough a control system and at least one processor.
9. The method of claim 1, wherein a plurality of acoustic wave sensors are printed on the piezoelectric substrate, and further comprising the step of separating the substrate and the acoustic wave sensors into individual acoustic wave sensors.
10. The method of claim 1, wherein the sensing film comprises a hydrophilic material.
11. The method of claim 1, wherein the sensing film comprises palladium.

12. The method of claim 1, wherein the sensing film comprises graphene.
13. The method of claim 1, wherein the sensing film comprises a carbon nanotube array.
14. The method of claim 1, wherein the sensor has a maximum dimension of less than 2mm^2 .
15. The method of claim 3, wherein the sensor layer and antenna layer are printed on opposing sides of the piezoelectric substrate layer.
16. The method of claim 15, wherein at least a portion of the sensor layer and the antenna layer are printed simultaneously.
17. An acoustic wave sensor, comprising:
 - a piezoelectric substrate layer;
 - a sensor layer joined to the substrate layer and comprising a first interdigitated acoustic wave transducer and at least one other feature selected from the group consisting of a sensing film, an interdigitated acoustic wave transducer, and a Bragg reflector;
 - wherein all of the interdigitated acoustic wave transducers and Bragg reflector are aerosol jet printed.

18. The acoustic wave sensor of claim 17, further comprising an antenna layer and an insulation layer interposed between the antenna layer and the sensor layer, and the insulation layer and antenna layer are aerosol jet printed.

19. The acoustic wave sensor of claim 18, wherein the at least one of the sensor layer and antenna layer comprise a dielectric matrix material.

20. The acoustic wave sensor of claim 18, wherein the sensor layer and the antenna layer are printed on opposing sides of the piezoelectric substrate layer.

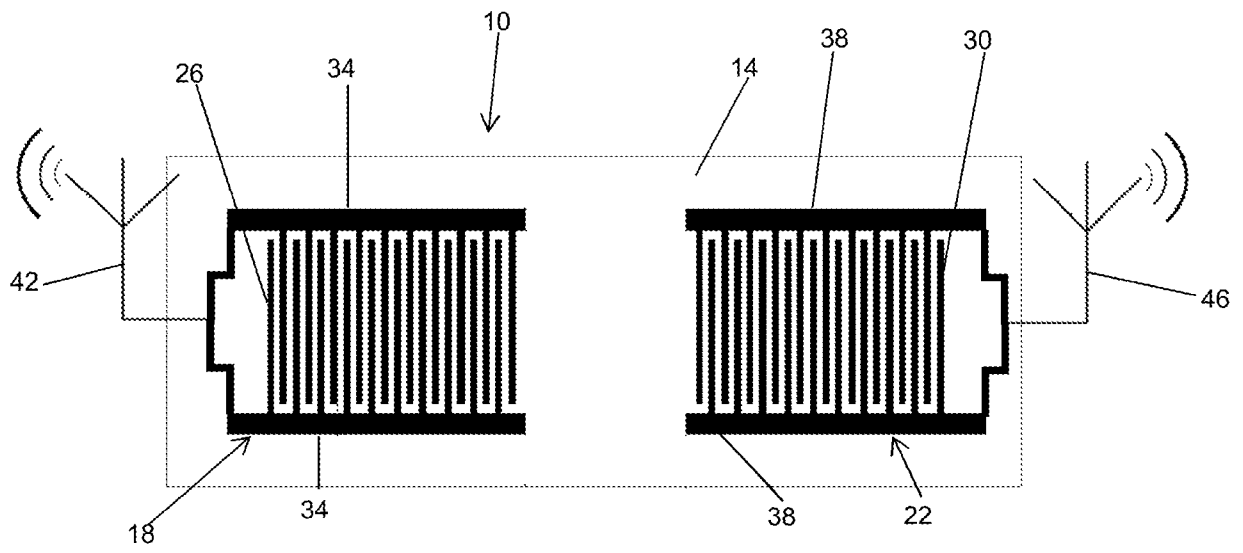

FIG. 1

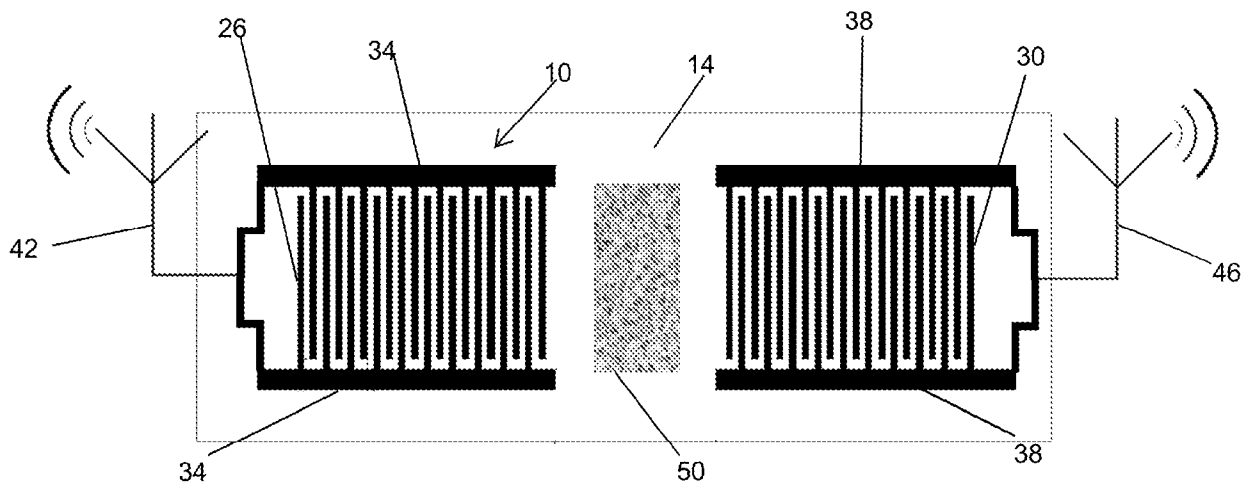
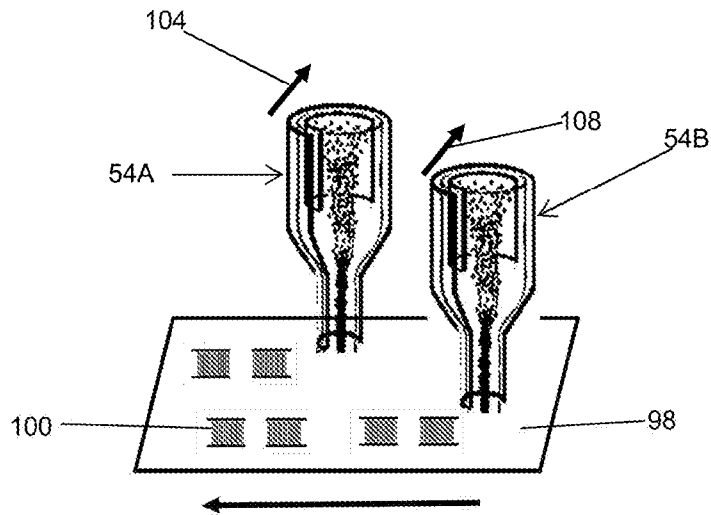
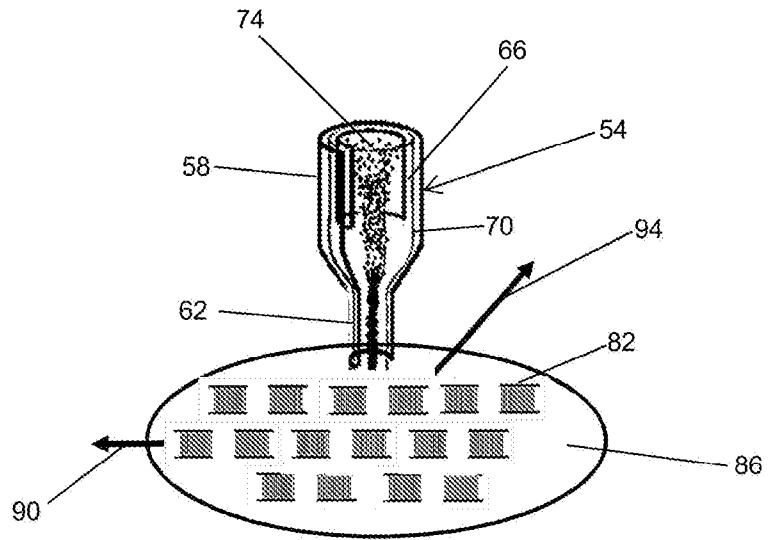

FIG. 2



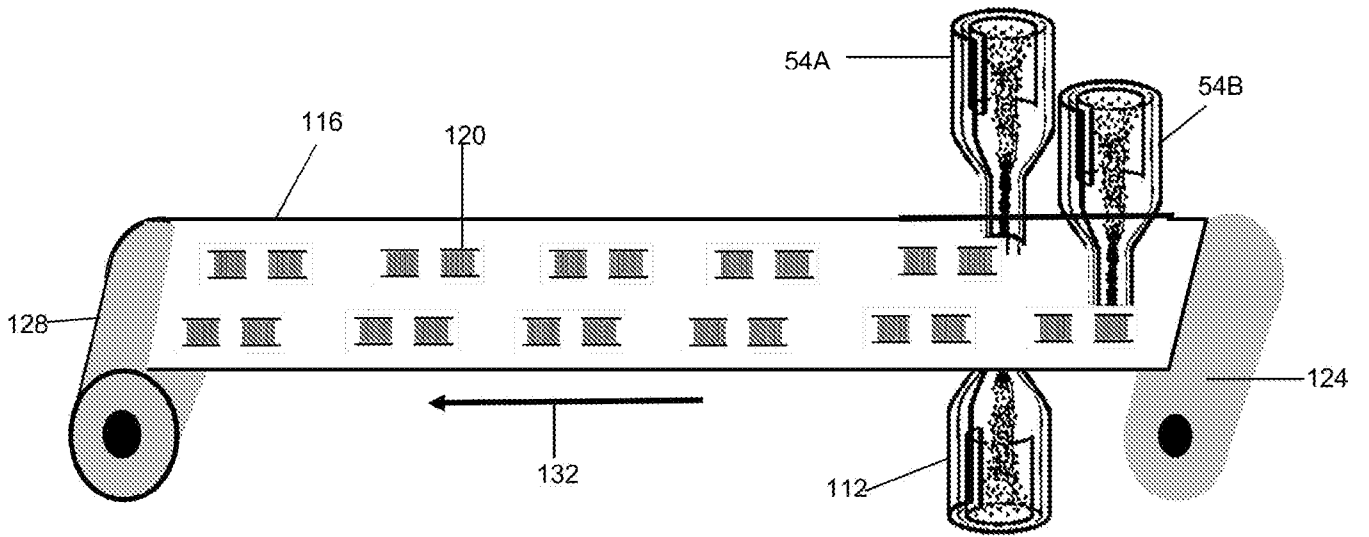

FIG. 5

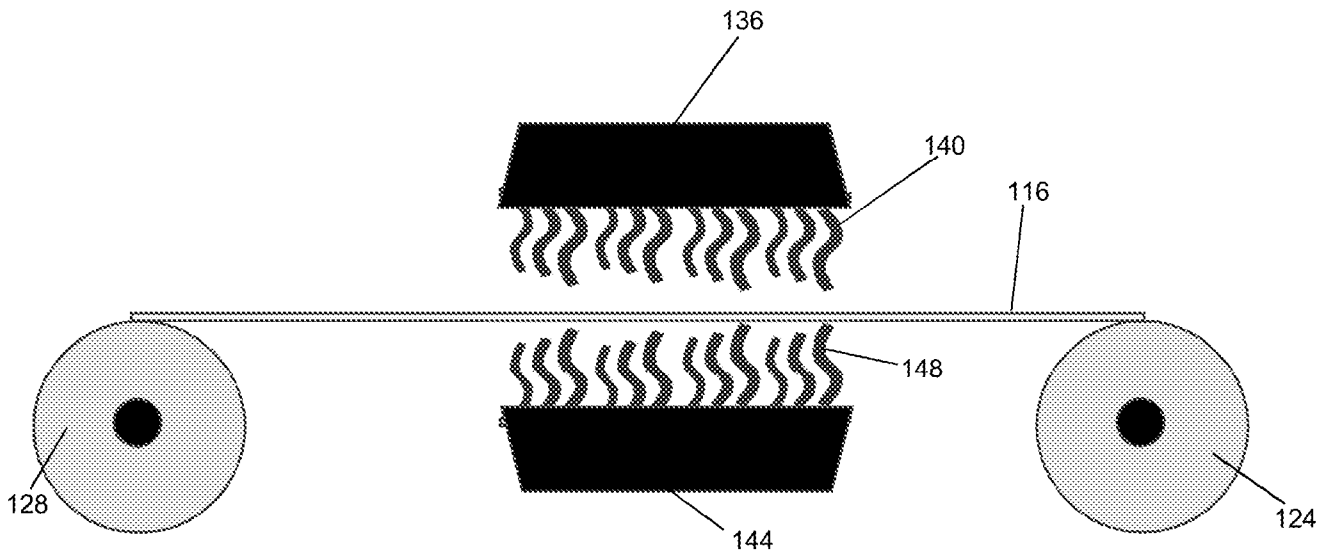

FIG. 6

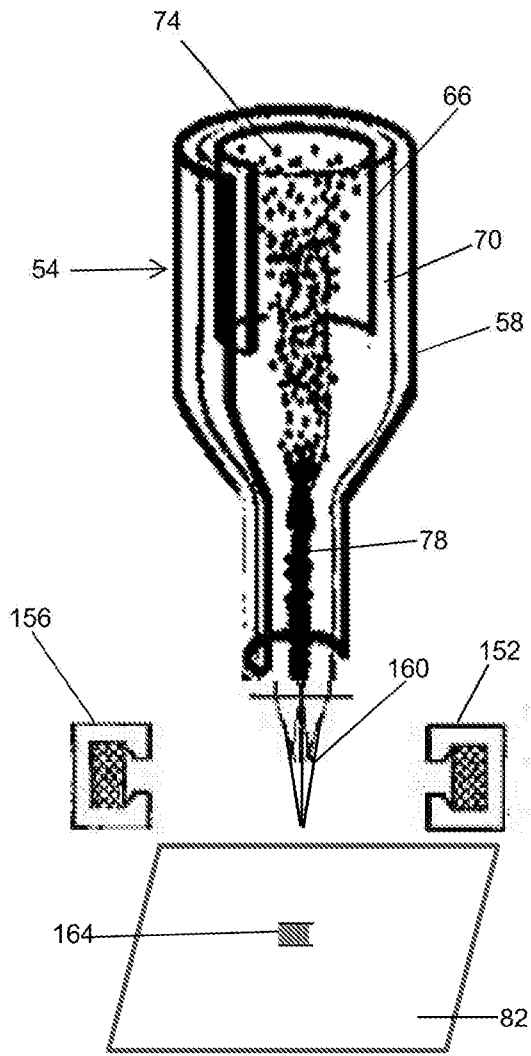

Fig. 7B

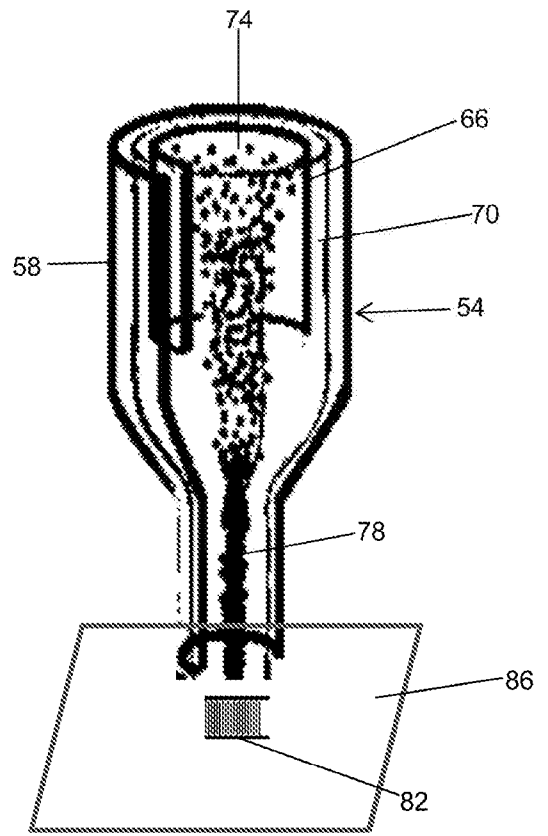

Fig. 7A

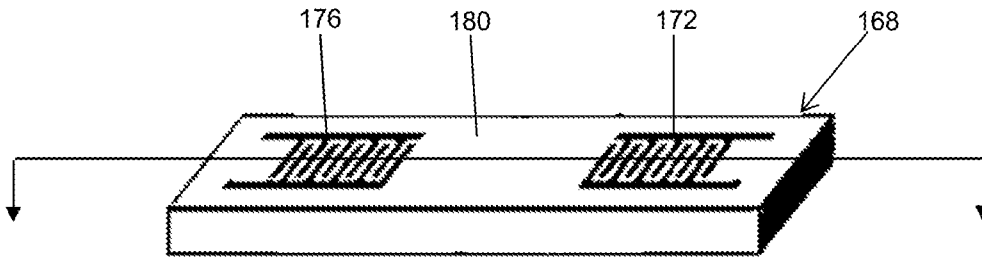

FIG. 8

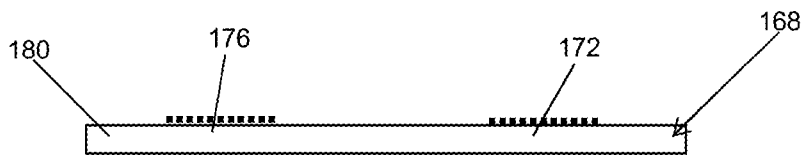

FIG. 9

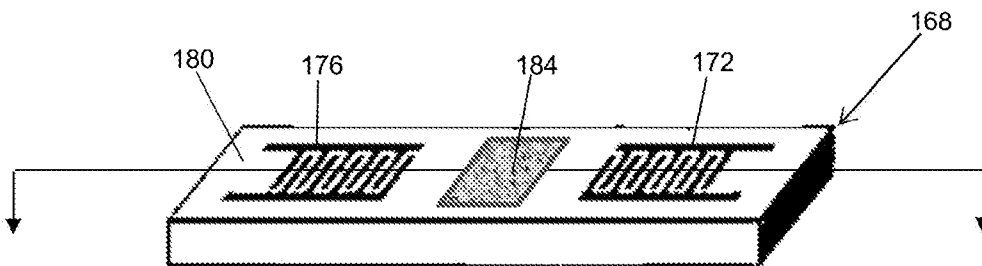

FIG. 10

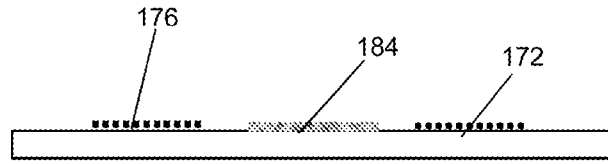

FIG. 11

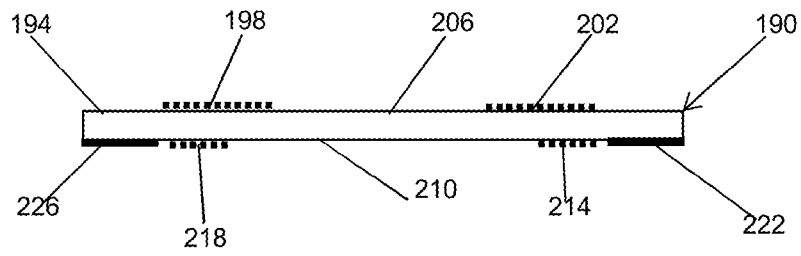

FIG. 12

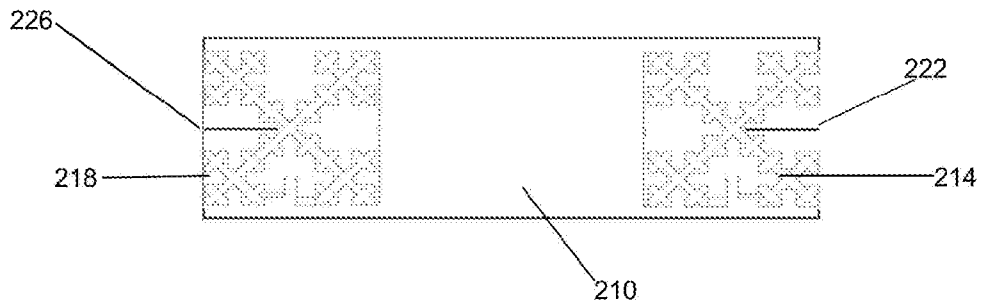

FIG. 13

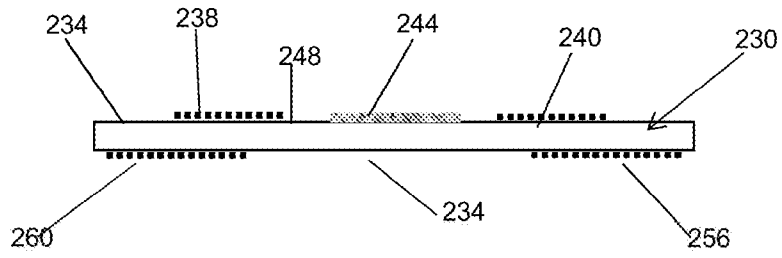

FIG. 14

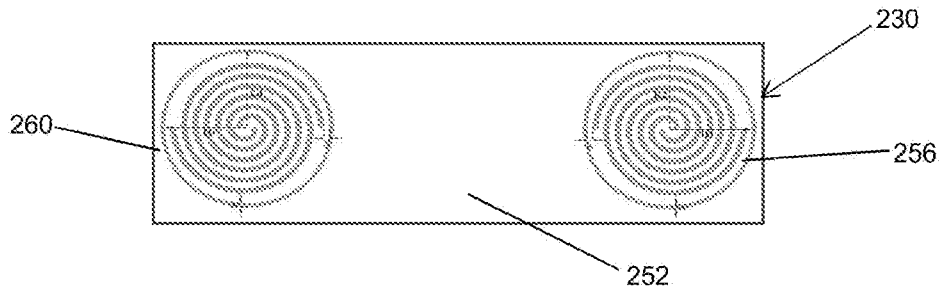

FIG. 15

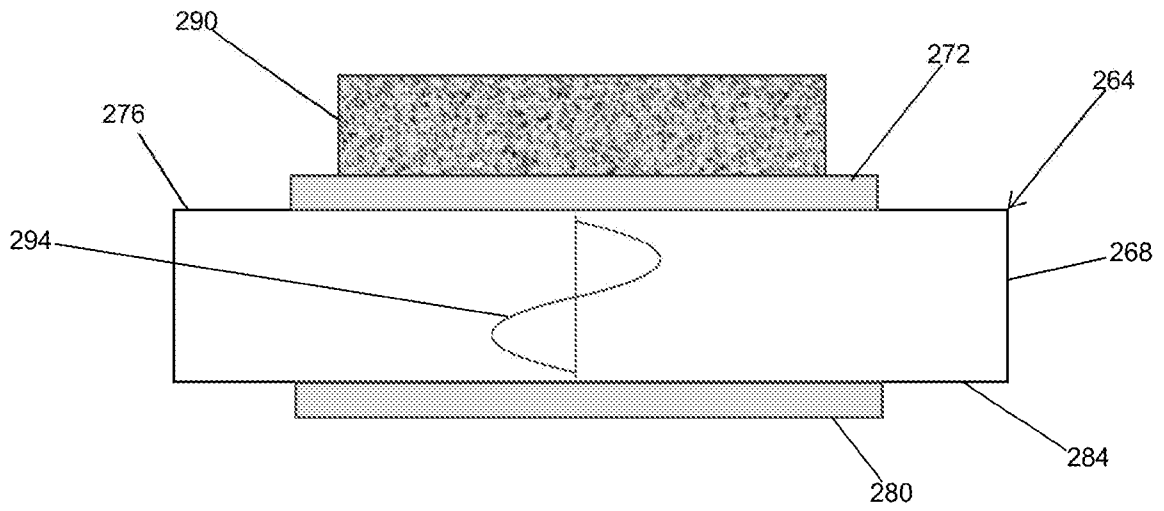

FIG. 16

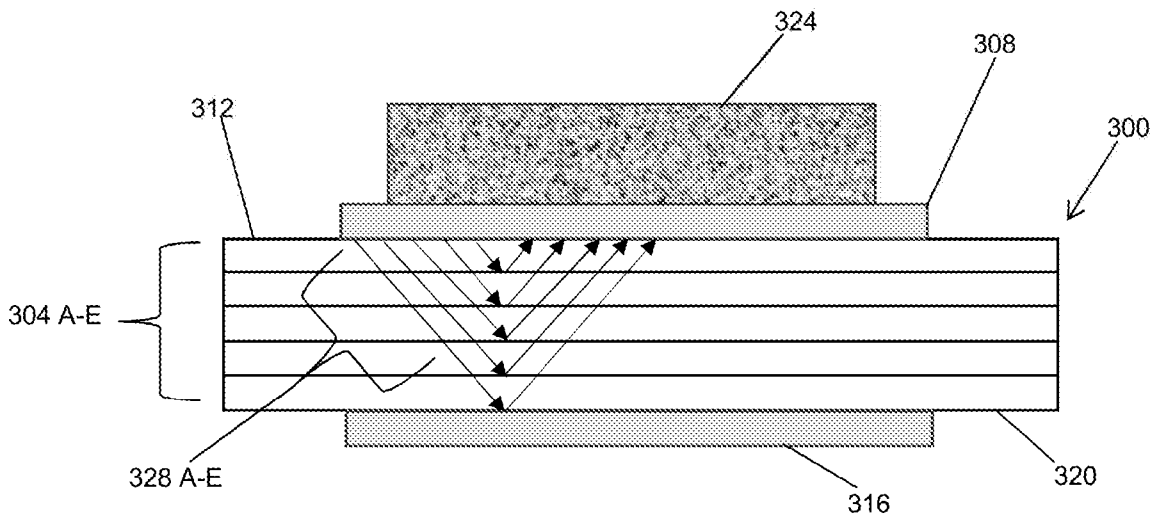

FIG. 17

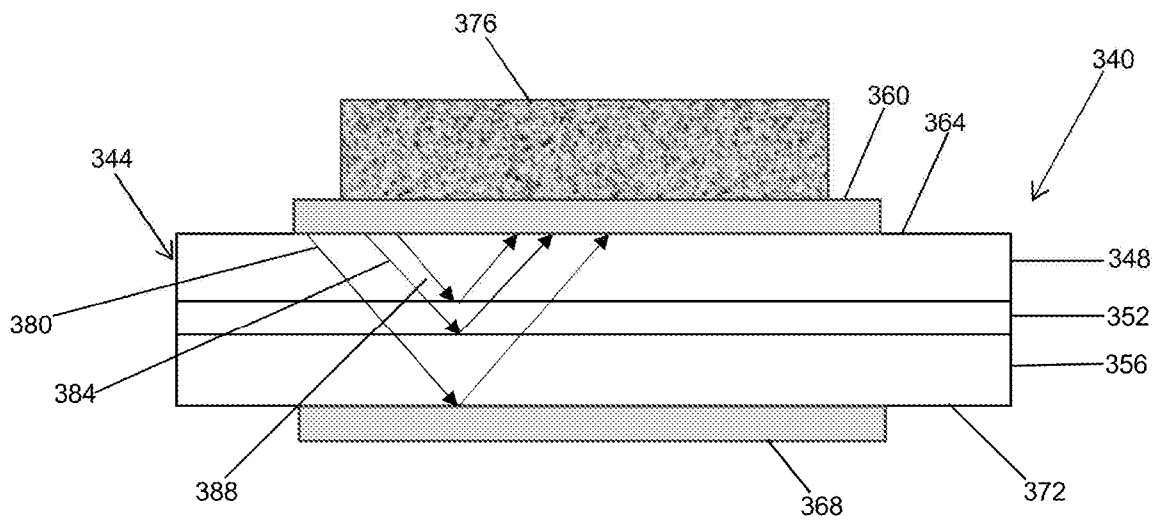

FIG. 18

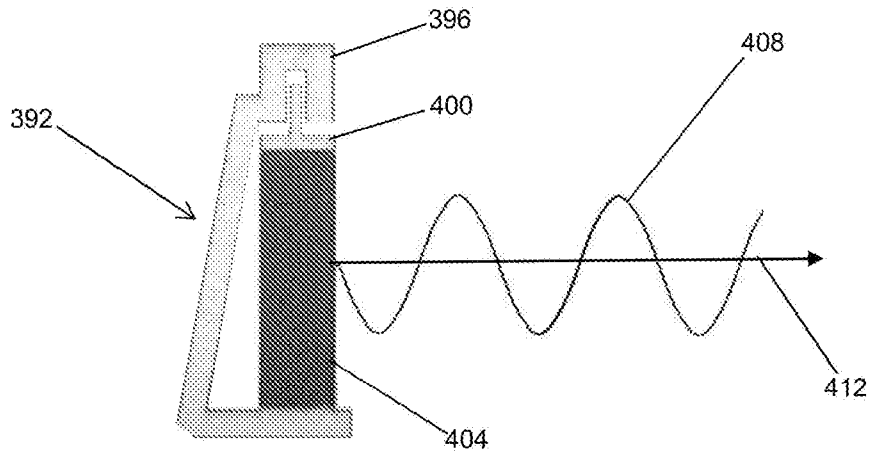

FIG. 19

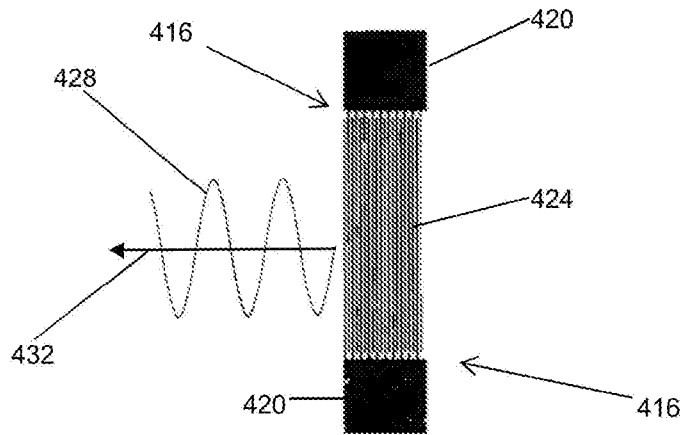

FIG. 20

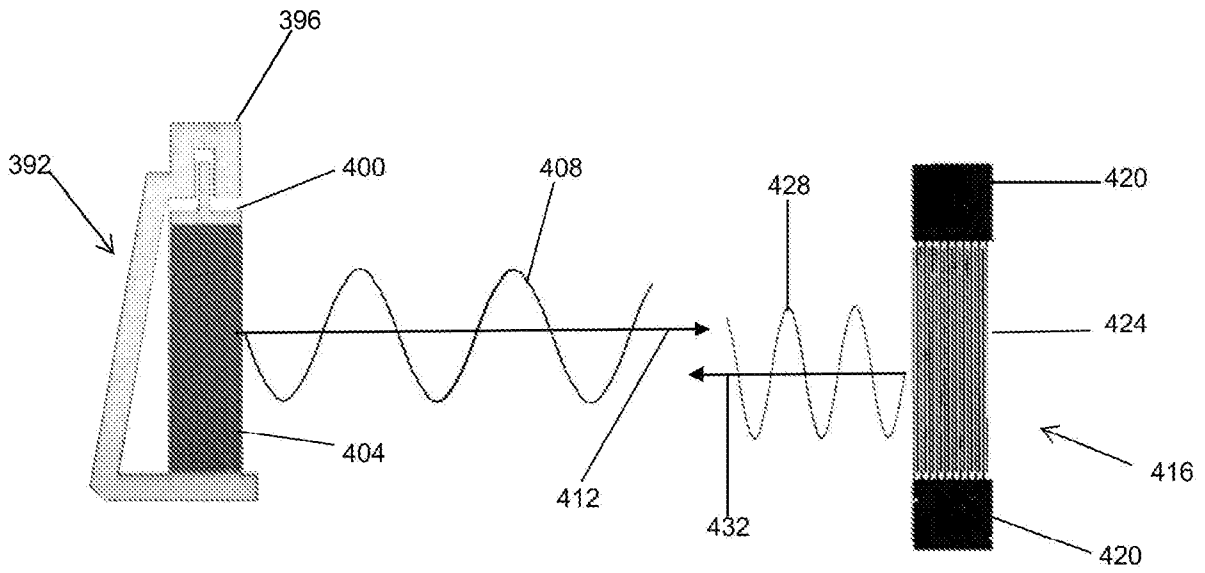

FIG. 21

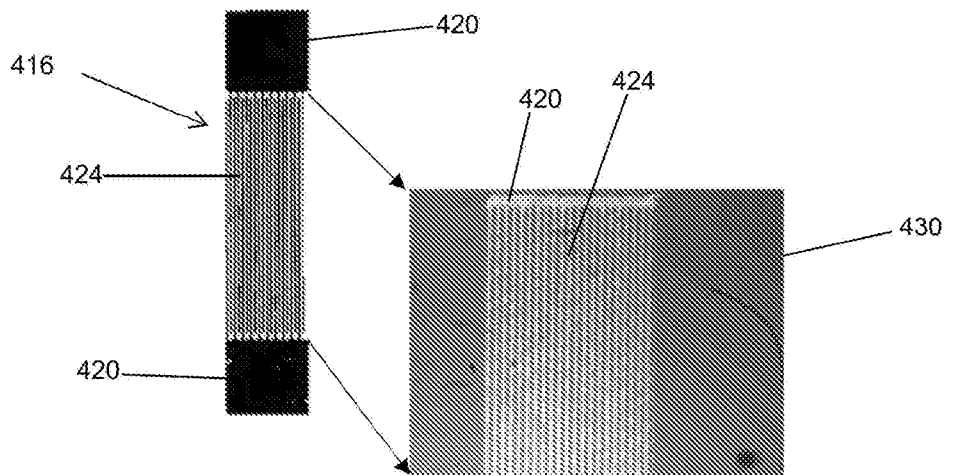

FIG. 22

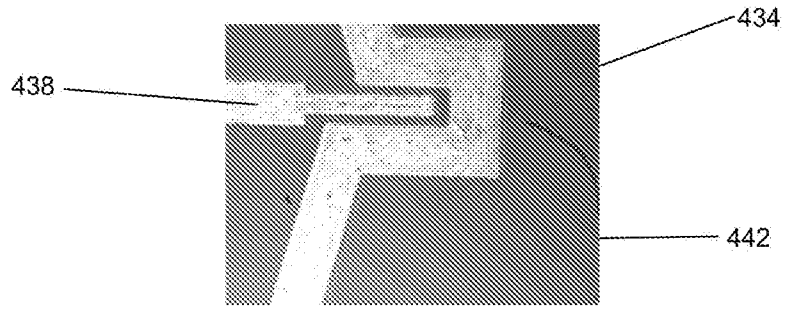

FIG. 23

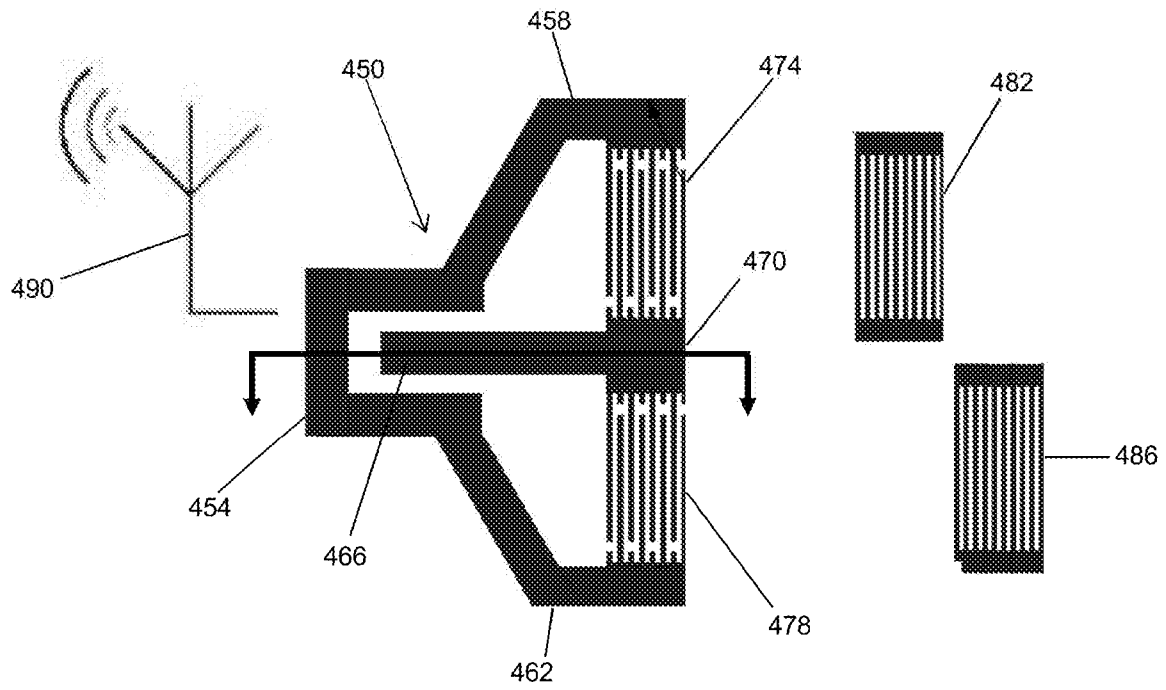
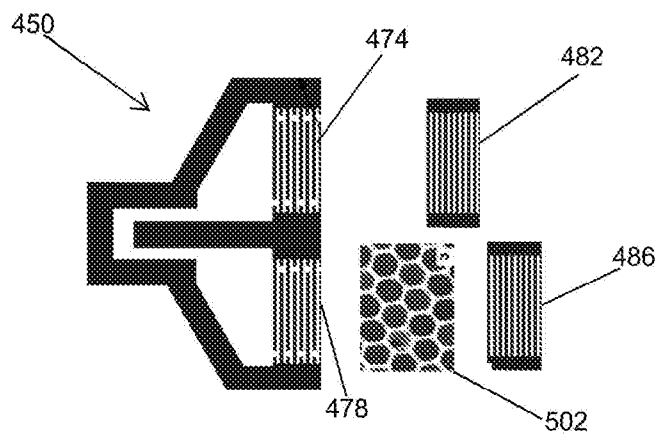
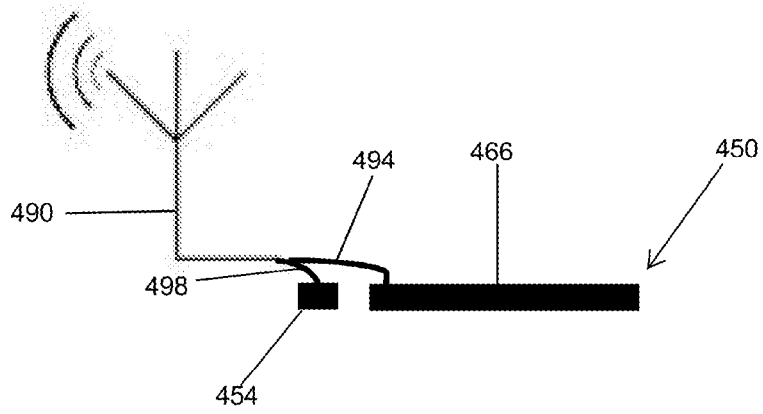

FIG. 24



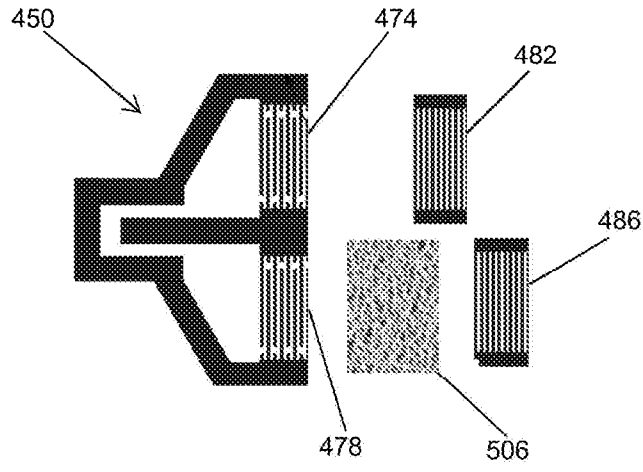

FIG. 27

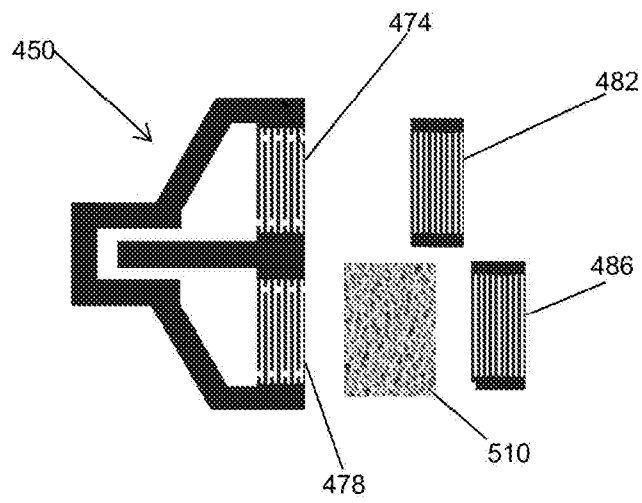

FIG. 28

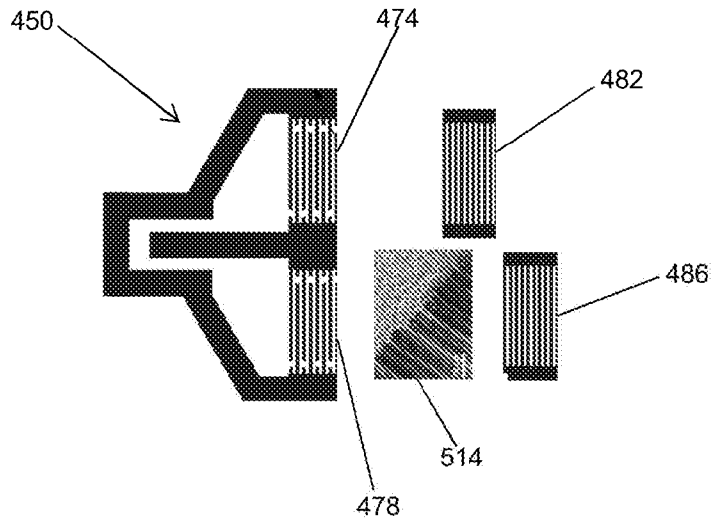

FIG. 29

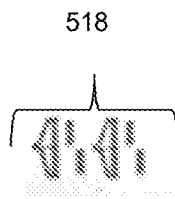

FIG. 30

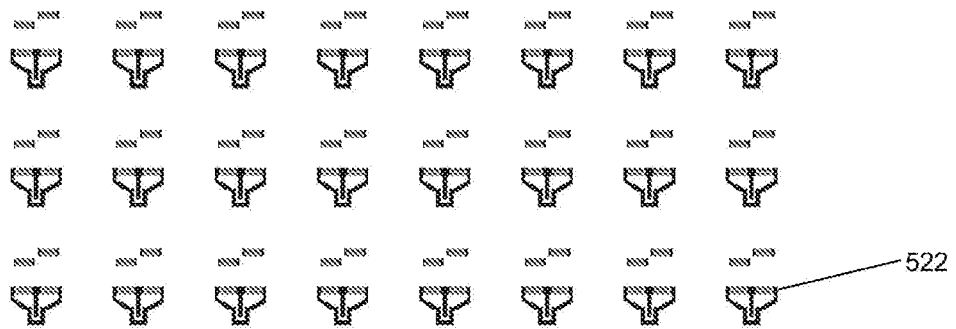

FIG. 31

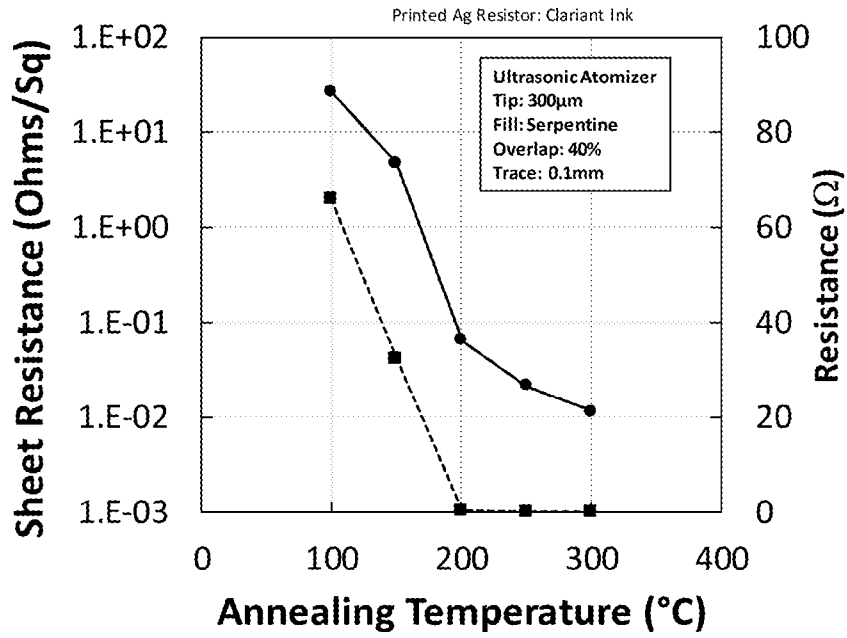

FIG. 32

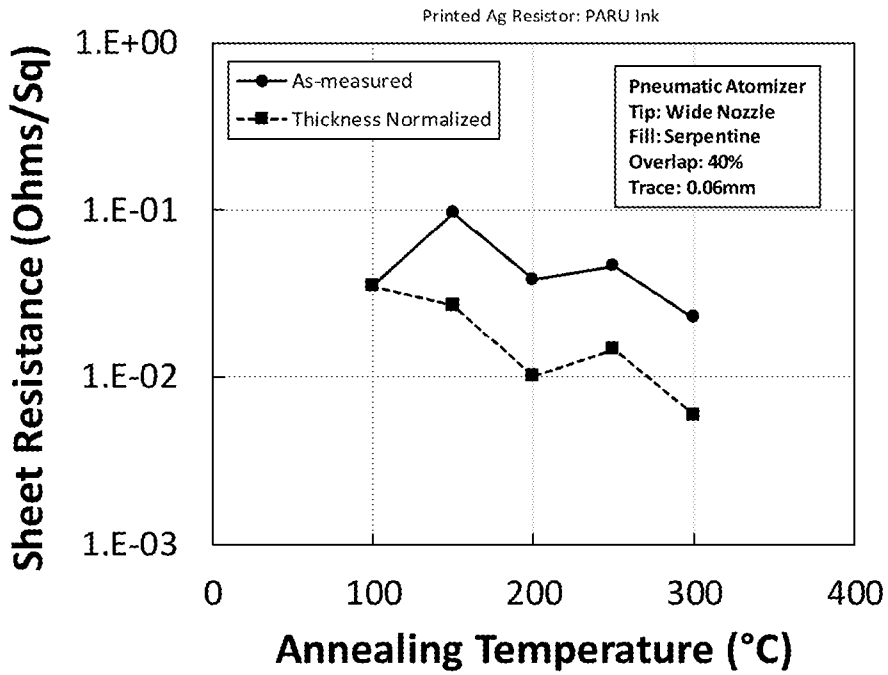

FIG. 33

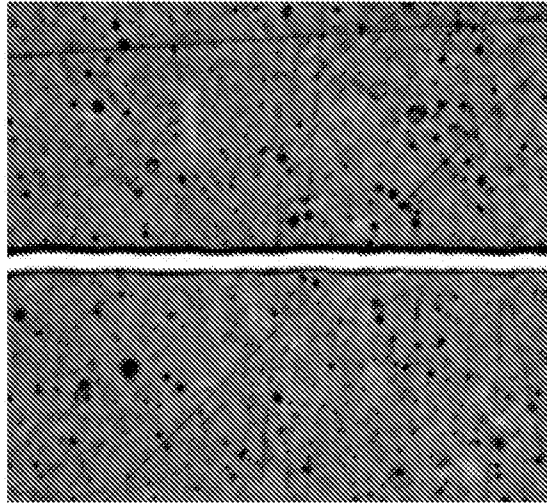

FIG. 34

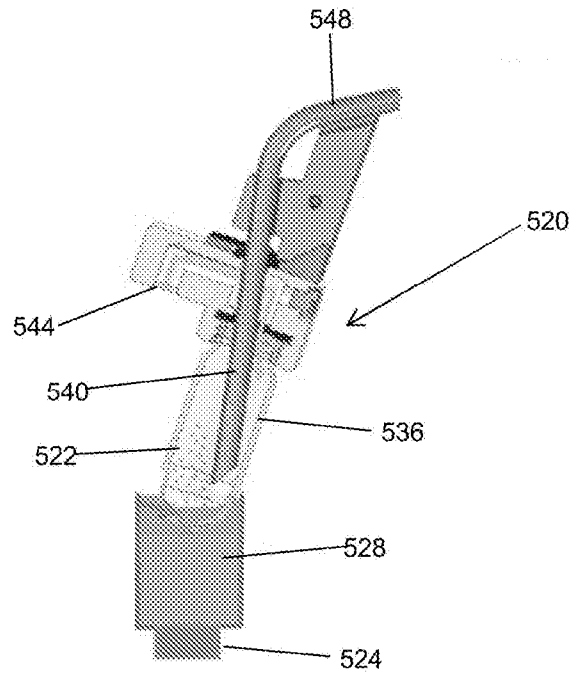

FIG. 35

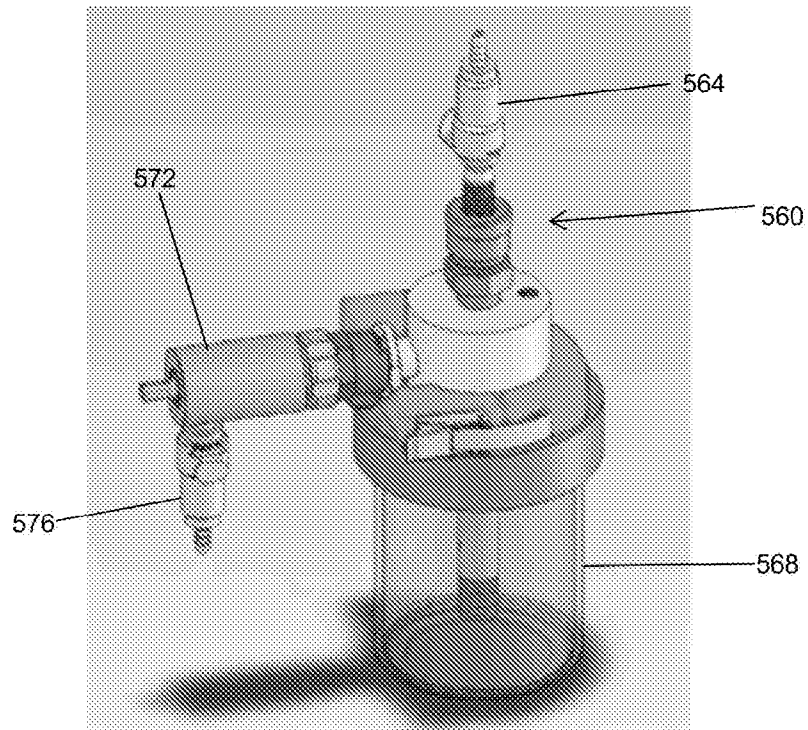

FIG. 36

INTERNATIONAL SEARCH REPORT

International application No.

PCT/US2016/048577

A. CLASSIFICATION OF SUBJECT MATTER IPC(8) - G01H 11/08; G01N 29/22 (2016.01) CPC - G01H 11/08; G01N 29/22 (2016.08) According to International Patent Classification (IPC) or to both national classification and IPC		
B. FIELDS SEARCHED Minimum documentation searched (classification system followed by classification symbols) IPC - B05D 5/00; G01H 11/00; G01H 11/08; G01N 29/00; G01N 29/22 CPC - B05D 5/00; G01H 11/00; G01H 11/08; G01N 29/00; G01N 29/22 Documentation searched other than minimum documentation to the extent that such documents are included in the fields searched USPC - 73/580; 73/649; 73/652; 118/641; 427/559 (keyword delimited) Electronic data base consulted during the international search (name of data base and, where practicable, search terms used) Patbase, Google Patents, Google Search terms used: piezoelectric, interdigitated transducer, acoustic wave sensor		
C. DOCUMENTS CONSIDERED TO BE RELEVANT		
Category*	Citation of document, with indication, where appropriate, of the relevant passages	Relevant to claim No.
Y	US 2005/0160821 A1 (CUNNINGHAM et al) 28 July 2005 (28.07.2005) entire document	1-20
Y	US 2013/0337190 A1 (RAMANUJAN et al) 19 December 2013 (19.12.2013) entire document	1-20
Y	US 2007/0007851 A1 (LOEBL et al) 11 January 2007 (11.01.2007) entire document	2, 5, 6
Y	US 2006/0000285 A1 (EDMONSON et al) 05 January 2006 (05.01.2006) entire document	3, 15, 16, 18-20
Y	US 6,579,660 B1 (FIGOV) 17 June 2003 (17.06.2003) entire document	4
Y	US 2003/0035558 A1 (KAWAMURA et al) 20 February 2003 (20.02.2003) entire document	9
Y	US 5,571,944 A (PFEIFER et al) 05 November 1996 (05.11.1996) entire document	10
Y	US 2012/0282594 A1 (CHEN et al) 08 November 2012 (08.11.2012) entire document	12, 13
<input type="checkbox"/> Further documents are listed in the continuation of Box C. <input type="checkbox"/> See patent family annex.		
* Special categories of cited documents: "A" document defining the general state of the art which is not considered to be of particular relevance "E" earlier application or patent but published on or after the international filing date "L" document which may throw doubts on priority claim(s) or which is cited to establish the publication date of another citation or other special reason (as specified) "O" document referring to an oral disclosure, use, exhibition or other means "P" document published prior to the international filing date but later than the priority date claimed "T" later document published after the international filing date or priority date and not in conflict with the application but cited to understand the principle or theory underlying the invention "X" document of particular relevance; the claimed invention cannot be considered novel or cannot be considered to involve an inventive step when the document is taken alone "Y" document of particular relevance; the claimed invention cannot be considered to involve an inventive step when the document is combined with one or more other such documents, such combination being obvious to a person skilled in the art "&" document member of the same patent family		
Date of the actual completion of the international search 19 October 2016		Date of mailing of the international search report 18 NOV 2016
Name and mailing address of the ISA/US Mail Stop PCT, Attn: ISA/US, Commissioner for Patents P.O. Box 1450, Alexandria, VA 22313-1450 Facsimile No. 571-273-8300		Authorized officer Blaine R. Copenheaver PCT Helpdesk: 571-272-4300 PCT OSP: 571-272-7774