



(72) O'SHEA, Darin L., US

(71) O'SHEA, Darin L., US

(51) Int.Cl.<sup>6</sup> E06B 1/12, E06B 3/12

(30) 1997/01/28 (08/787,700) US

(54) **STRUCTURE DE CADRE DE FENETRE**

(54) **WINDOW FRAME ASSEMBLY**

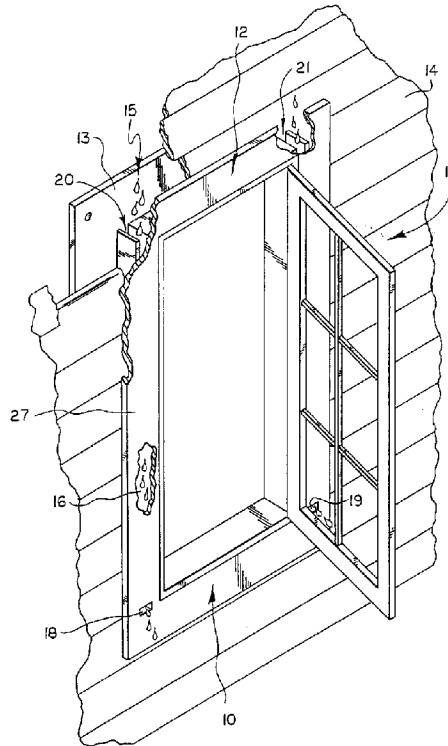

(57) Structure de cadre de fenêtre comportant un cadre et une canalisation en forme de J intégrée au cadre de fenêtre. L'élément en forme de J comporte des drains intégrés servant à canaliser et à dévier l'eau de manière à l'éloigner du cadre de fenêtre.

(57) A window frame assembly comprising a window frame and a J-channel member integral with the window frame, the J-channel member containing integral drains operatively arranged to constrain and divert water away from the window frame.

**ABSTRACT OF THE DISCLOSURE**

A window frame assembly comprising a window frame and a J-channel member integral with the window frame, the J-channel member containing integral drains operatively arranged to constrain and divert water away from the window frame.

### **FIELD OF THE INVENTION**

This invention relates generally to window frames, and, more particularly, to an improved window frame assembly having integral J-channel which contains integral drains.

### **BACKGROUND OF THE INVENTION**

10 A problem with many window and door frame assemblies, and with aluminum and vinyl siding which border these frame assemblies, is that they permit water to drain behind the siding itself, creating damage to the house or other structure. Typically, a window or door frame is mounted within an opening in a structure and then vinyl or aluminum siding is secured about the frame. It is common in the industry to mount J-channel about the periphery of the window frame and onto the underlying structure and then to secure the siding directly to the J-channel. Unfortunately, present J-channel construction, in combination with the way the siding is mounted, permits water to travel behind the siding, causing structural damage.

20 One attempt to solve this problem has been made by Simonton Building Products, Inc. who recently introduced a "Profinish" line of windows containing integral J-channel on the window frame. While this product is certainly an improvement, the J-channel merely functions to channel rainwater from the top of the window frame to the sides, still permitting the water to infiltrate the area behind the siding.

What is needed, then, is a window frame assembly which provides a means for rainwater to drain safely away from the underlying structure to prevent water damage.

### **BRIEF SUMMARY OF THE INVENTION**

The invention provides a window frame assembly comprising a window frame and a J-channel member integral with the window frame, the J-channel member containing integral drains operatively arranged to constrain and divert water away from the window frame. The J-channel member comprises four sections which surround the window frame: an upper window jamb section, a lower window sill section, a first vertical section, and a second vertical section. The J-channel itself comprises an interior nailing flange, and exterior flange and a bridge member. The bridge member in the upper window jamb section contains openings to drain channels which run vertically downward inside and adjacent the bridge members of the vertical sections. The drain channels receive rainwater from the upper window jamb section and expel the water from the bottom of the window and along the exterior surface of siding or other structure covering.

The invention is not limited to a window frame assembly, but also pertains to any opening in a structure, such as a door, air conditioner opening, electrical junction box opening, or the like.

The primary object of the invention is to provide a frame assembly for an opening in a structure which provides a means of draining water from the assembly and preventing water from causing damage to the structure.

These and other objects, features and advantages of the invention will become readily apparent to one having ordinary skill in the art from the following description of the invention, attached drawings, and appended claims.

### **IN THE DRAWINGS**

10 Figure 1 is a fragmentary exterior elevation view of the window frame assembly of the invention installed in a structure;

Figure 2 is a front view of the window frame assembly shown in Figure 1, isolated from the structure;

Figure 3 is a side view of the window frame assembly shown in Figure 2;

Figure 4 is a rear view of the window frame assembly shown in Figure 1, isolated from the structure;

Figure 5 is a side view of the window frame assembly shown in Figure 4;

Figure 6 is a top view of the window frame assembly shown in Figure 2;

20 Figure 7 is a top view of the window frame assembly shown in Figure 4;

Figure 8 is an enlarged fragmentary view of the top of the J-channel section of the window frame assembly shown in Section A in Figure 2;

Figure 9A is an enlarged fragmentary view of the bottom of the J-channel section of the window frame assembly shown in Section B in Figure 3;

Figure 9B is a view similar to that of Figure 9A showing an alternative embodiment of the bottom of the J-channel section of the window frame assembly shown in Section B in Figure 3;

Figure 10 is an enlarged view of Section C in Figure 2, showing one of the drains of the window frame assembly;

10 Figure 11 is a cross-sectional view taken along plane 11-11 in Figure 2;

Figure 12 is an exterior elevation view of the door frame assembly of the invention installed in a structure;

Figure 13 is a side view of the door frame assembly shown in Figure 12;

Figure 14 is an enlarged fragmentary view of Section D of the door frame assembly shown in Figure 12;

Figure 15A is an enlarged fragmentary view of Section E of the door frame assembly shown in Figure 13;

Figure 15B is a view similar to that of Figure 15A showing an alternative embodiment of Section E of the door frame assembly shown in Figure 13;

20 Figure 16 is a cross-sectional view of the door frame assembly taken along plane 16-16 in Figure 12;

Figure 17 is a fragmentary exterior elevation view of an alternative embodiment of the lower left window frame assembly shown in Figure 1.

### **DESCRIPTION OF THE SPECIFIC EMBODIMENT**

At the outset, it should be clearly understood that the drawings are to be read together with the specification, and are to be considered a portion of the entire "written description" of this invention, as required by 35 U.S.C. § 112. Also, identical reference numerals on different figures refer to identical elements of the invention. It should also be understood that the word "window" is intended to mean any opening within a structure, including but not limited to a door opening, vent, air conditioner opening, electric meter box, light fixture, chimney, electrical receptacle, or the like.

Adverting now to the drawings, Figure 1 is a fragmentary exterior elevation view of the window frame assembly 10 of the invention installed in a structure 11, such as a house. In this embodiment the house is covered with vinyl siding 14. Window frame assembly 10 broadly comprises J-channel member 12 integral therewith. The J-channel includes nailing flange 13, exterior flange 27, and bridge member 28 (shown in Figure 3) connecting the flanges together. The nailing flange is used to mount the window frame assembly to the house and also functions as a base upon which the vinyl siding is secured proximate the window. The J-channel member is arranged about the periphery of the window frame assembly, and it is seen that siding 14 is

“sandwiched” between the nailing flange and the exterior flange. An obvious problem with prior art window assemblies is that rain water (illustrated by drops 15) is permitted to flow behind the vinyl siding, thereby causing structural damage. The present invention provides drain channels within the J-channel on each vertical side of the window to drain water along the outside surface of the siding, preventing flow behind the siding. This feature of the invention will be described in more detail *infra*.

10 Figure 2 is a front view of the window frame assembly shown in Figure 1, isolated from the structure. J-channel 12 comprises four sections: upper window jamb section 22, lower window sill section 23, first vertical section 24, and second vertical section 25. Shown in phantom in Figure 2 are drain channels 16 and 17, respectively, which are integral to the J-channel member. Rain water enters the channels at openings 20 and 21, respectively (shown in Figure 1), and leaves the channels at openings 18 and 19, respectively. In this particular embodiments, openings 18 and 19 provide an outlet to the front of J-channel member 12. In an alternative embodiment shown in Figure 17, the openings outlet to the rear of the J-channel member, and the water flows down the exterior surface of the vinyl siding. This is perhaps a more aesthetically pleasing outlet structure, as the water flow is not plainly visible.

20 Figure 3 is a side view of the window frame assembly shown in Figure 2. As shown in this view, J-channel member 12 comprises nailing flange 13, exterior flange 27 and bridge member 28 which joins the flanges together. The

flanges and the bridge member extend about the periphery of the window frame assembly. Exterior flange 27 functions to constrain rain water on the bridge section between the two flanges. On the upper window jamb section, the water is directed into inlets 20 and 21. Also shown in Figure 3 is frame member 26 which is secured inside the opening in the structure.

Figure 4 is a rear view of the window frame assembly shown in Figure 1, isolated from the structure, and Figure 5 is a side view of the assembly shown in Figure 4.

10 Figure 6 is a top view of the window frame assembly shown in Figure 2 and Figure 7 is a bottom view of the window frame assembly shown in Figure 4. As shown in Figure 6, bridge member 28 in the upper jamb section includes drain inlets 20 and 21. Rain water which collects on the upper window jamb section flows into these openings and into their respective drain channels. Inlet 20 allows water to flow into drain channel 16 and inlet 21 allows water to flow into drain channel 17 (shown in phantom in Figures 2 and 4). Inlet 21 to drain channel 17 is shown in detail in fragmentary cross-sectional view in Figure 8, which is an enlarged view of Section A of the assembly shown in Figure 3. As described previously, rain water collects on the surface of bridge member 28 and flows into the drain inlets.

Outlet 19 of drain channel 17 is shown in more detail in fragmentary cross-sectional view in Figure 9A, which is an enlarged view of Section B of the assembly shown in Figure 3. Water travels downwardly through channel 17 and is expelled via outlet 19 to the front of the window frame assembly. As shown in Figure 9A, water in channel 17 is directed to the bottom 68 of channel 17. Outlet 19 is formed in flange 27 and flange extension 56. Figure 9B illustrates an alternative embodiment in which outlet 19 releases water "behind" flange 27. In this embodiment, outlet 19 is formed by flange 27 and bottom floor 68. The expelled water in this embodiment flows down the exterior surface of the vinyl siding.

10

Outlet 19 is also shown in detail in Figure 10 which is an enlarged view of Section C shown in Figure 2.

Figure 11 is a cross-sectional view taken along plane 11-11 in Figure 2. In addition to the structural elements of the invention previously described, Figure 11 also shows window pane 30 secured to casement 29, window jamb 32, and mullion 31.

The present invention may take the form of several embodiments. Described thus far is the window frame assembly embodiment. It should be readily apparent to one having ordinary skill in the art, however, that the invention may take the form of a door frame embodiment as illustrated in Figures 12-16, and may also find application in any opening in a dwelling or building structure, such as vents, air conditioners, electric meter boxes, lights, chimneys, and the like.

Adverting now to Figure 12, door frame assembly 40 is illustrated in an exterior elevation view. Door 41 is shown encased by frame 42 which comprises the invention. J-channel 55 comprises nailing flange 45, exterior  
10 flange 47 and bridge member 48. The J-channel comprises first vertical section 61, upper door jamb section 62, and second vertical section 63. Vertical sections 62 and 63 contain drains 50 and 51, respectively, shown in phantom, which drain rainwater from the bridge member 48 of the J-channel. As shown in the drawing, drain channels 50 and 51 dispel water from outlets 56 and 53, respectively.

Figure 13 is a side view of the frame assembly shown in Figure 12. The frame assembly includes J-channel 55, nailing flange 45 and frame member 46 which would be mounted inside the opening in the structure. The J-channel  
20 member is shown as having exterior flange 47, bridge member 48 and nailing flange 45. A difference between the window frame embodiment and the door frame embodiment is illustrated in Figure 15A, which is an enlarged fragmentary

view of section E of the assembly shown in Figure 13. Comparing Figure 15A with Figure 9A, it is seen that the J-channel assembly shown in Figure 9A includes drip extension piece 56, whereas the assembly shown in Figure 15A has no such extension. As shown in Figure 15A, outlet 53 expels water from drain channel 51 from floor 65 of drain 51. This expelled water would land on the bottom door sill and then travel to the door stoop. Figure 9B illustrates an alternative embodiment of the drain. In this embodiment, outlet 64 is formed by extension 66 of flange 47 and floor 65 of drain 51. This embodiment would permit water to drain into a door channel beneath the door frame, as opposed to allowing the water to flow across the door sill and door stoop.

10

Right inlet 52 is shown in enlarged fragmentary view in Figure 14, which is an enlargement of section D of Figure 12. This inlet permits rain water to exit bridge 48 into drain channel 51. A corresponding left inlet (not shown) permits water to exit bridge 48 into drain channel 50.

Finally, Figure 16 is a cross-sectional view taken along plane 16-16 in Figure 12. In addition to the structural elements of the invention previously described, Figure 16 also shows door jamb 53.

Thus, it is seen that the invention effectively achieves its purposes of providing an improved window frame assembly which eliminates a potential water damage problem by channelling and draining rain water through the window frame assembly. It will be understood that the foregoing description is illustrative of the invention and should not be considered as limiting and that other embodiments of the invention are possible without departing from the invention's spirit and scope, as embodied in the following claims.

The embodiments of the invention in which an exclusive property or privilege is claimed are defined as follows:

1. A window frame assembly comprising:  
a window frame; and,  
a J-channel member integral with said window frame, said J-channel member containing integral drains operatively arranged to constrain and divert water away from said window frame.
2. A window frame assembly as recited in Claim 1 wherein said J-channel member comprises a nailing flange, an exterior flange and a bridge member connecting said flanges.
3. A window frame assembly as recited in Claim 2 wherein said J-channel comprises four sections: an upper window jamb section, a lower window sill section, a first vertical section, and a second vertical section.
4. A window frame assembly as recited in Claim 3 wherein said first vertical section and said second vertical section each contain drain channels, said bridge member in said upper window jamb section contains inlets to said drain channels, and said drain channels direct water away from said window frame.

5. A window frame assembly as recited in Claim 2 wherein said nailing flange is used to secure said J-channel to a structure and also provides a flat surface for mounting of siding.

6. A window frame assembly as recited in Claim 2 wherein said exterior flange functions to constrain water between said nailing flange and said exterior flange.

7. A door frame assembly comprising:

10

a door frame; and,

a J-channel member integral with said door frame, said J-channel member containing integral drains operatively arranged to constrain and divert water away from said door frame.

8. A door frame assembly as recited in Claim 7 wherein said J-channel member comprises a nailing flange, an exterior flange and a bridge member connecting said flanges.

20

9. A door frame assembly as recited in Claim 8 wherein said J-channel comprises three sections: an upper door jamb section, a first vertical section, and a second vertical section.

10. A door frame assembly as recited in Claim 9 wherein said first vertical section and said second vertical section each contain drain channels, said bridge member in said upper door jamb section contains inlets to said drain channels, and said drain channels direct water away from said door frame.

11. A door frame assembly as recited in Claim 9 wherein said nailing flange is used to secure said J-channel to a structure and also provides a flat surface for mounting of siding.

10 12. A door frame assembly as recited in Claim 9 wherein said exterior flange functions to constrain water between said nailing flange and said exterior flange.

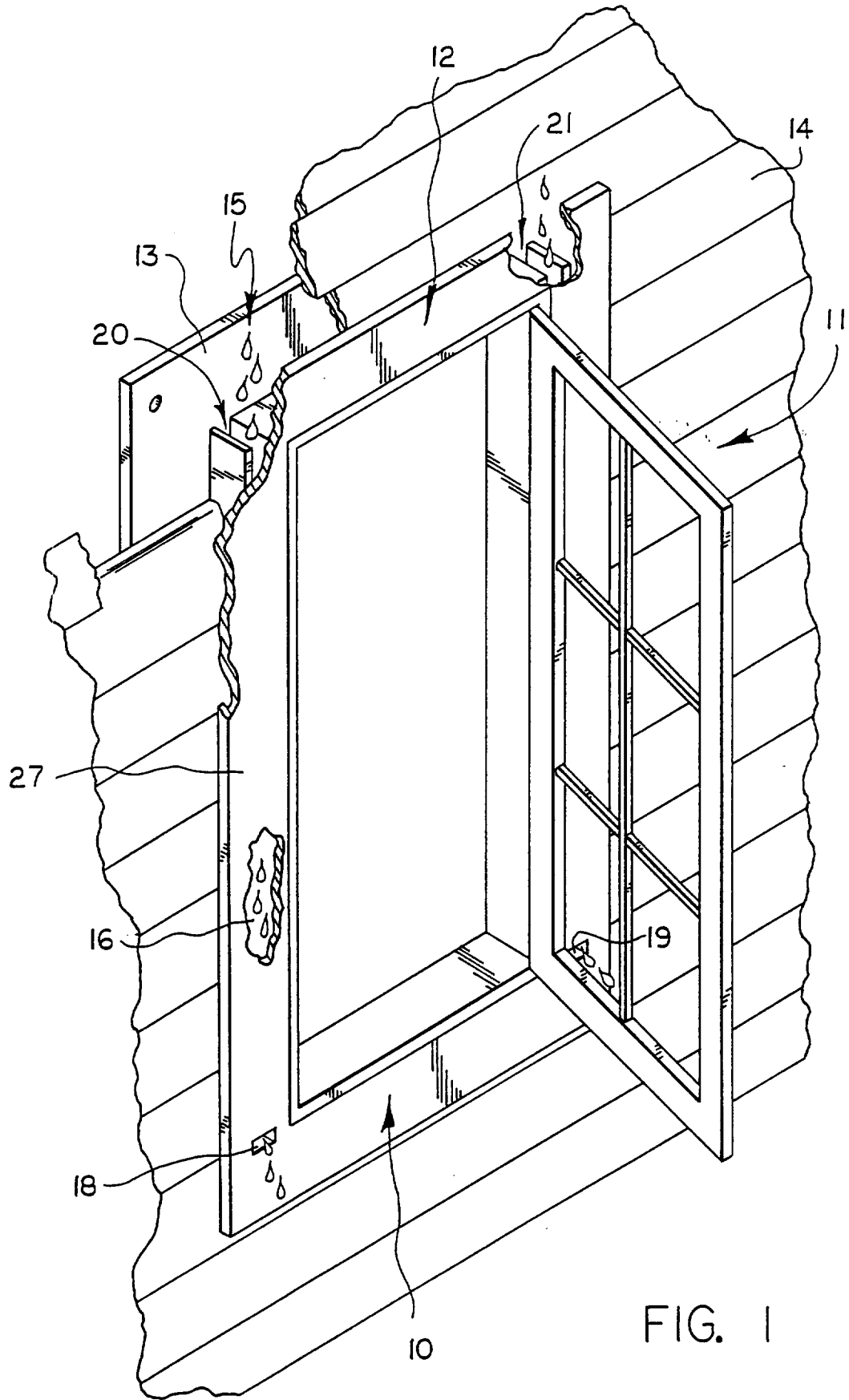

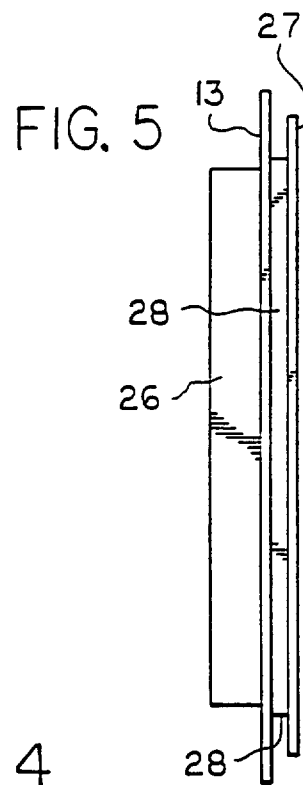
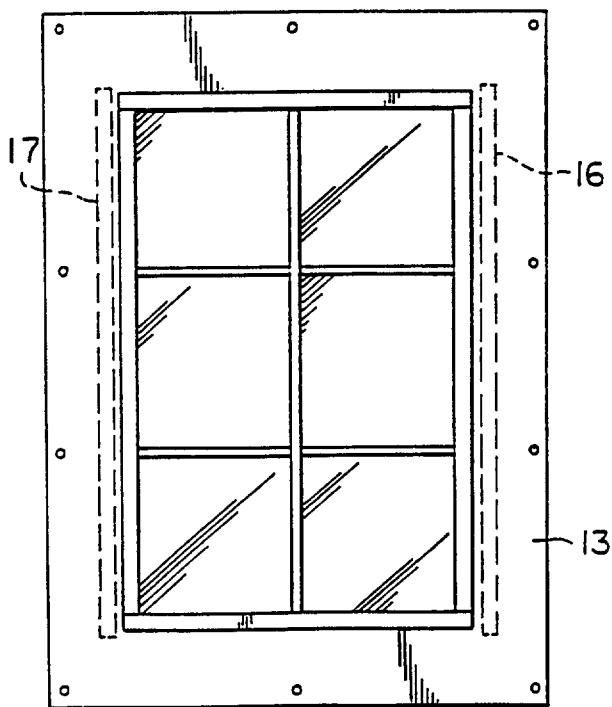
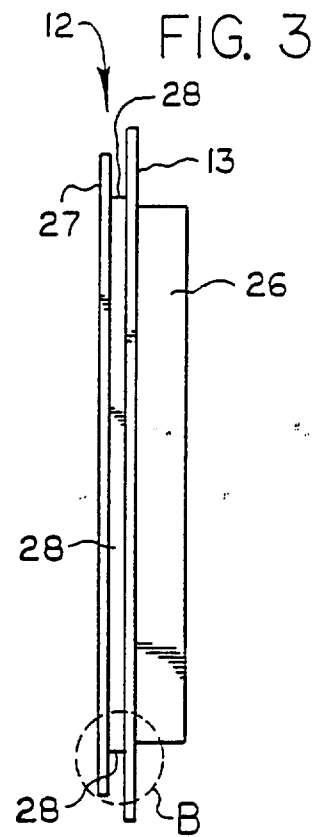
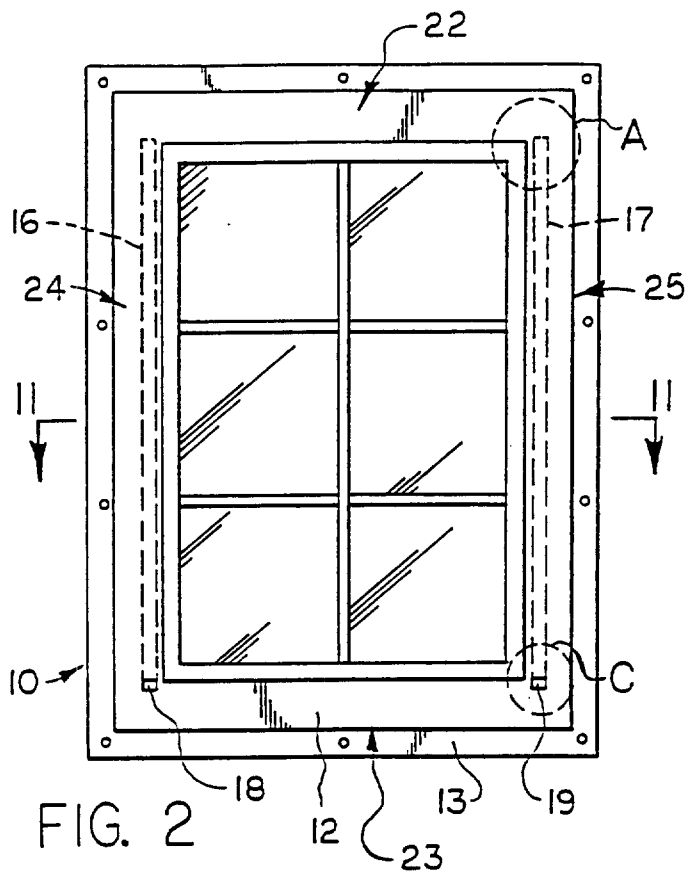

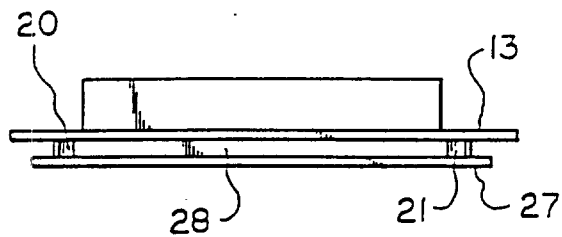

FIG. 6

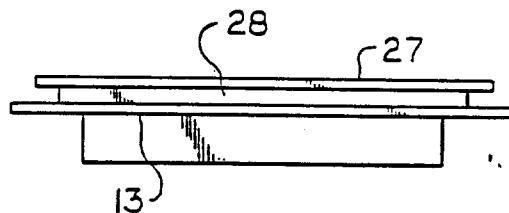

FIG. 7

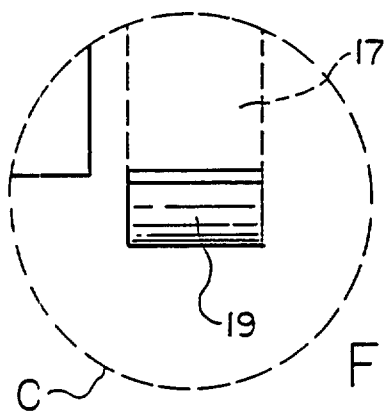
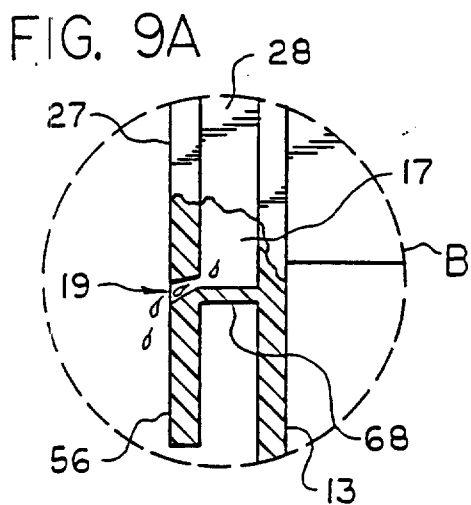

FIG. 10

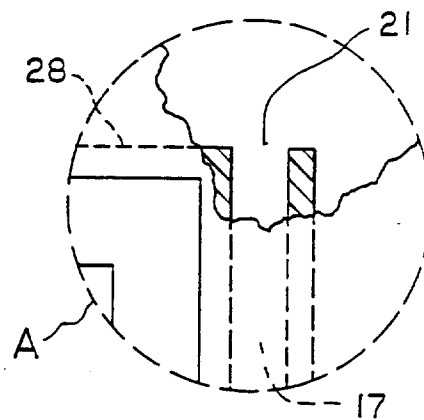

FIG. 8

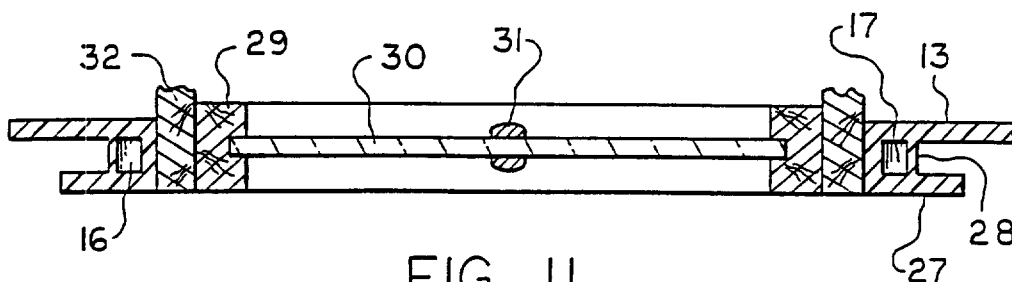

FIG. 11

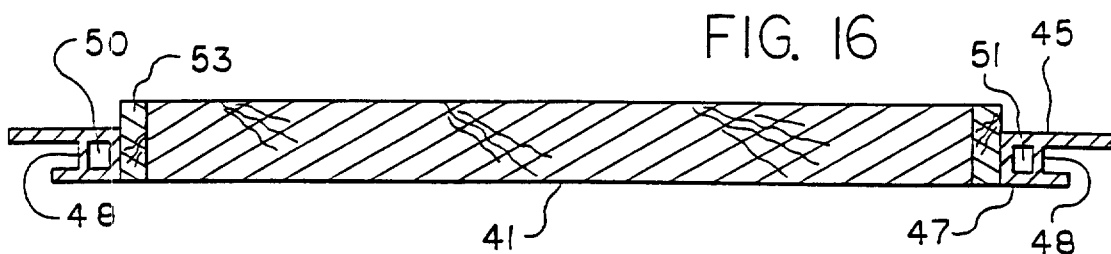
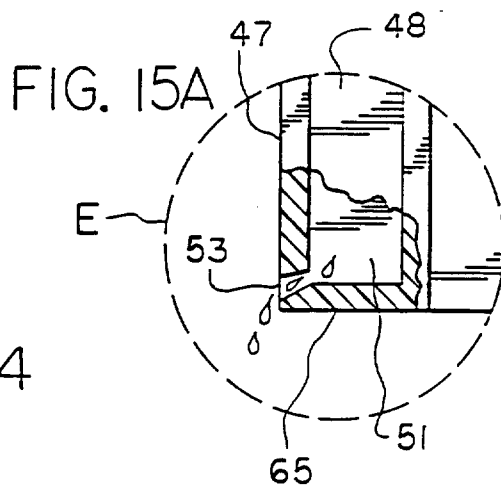
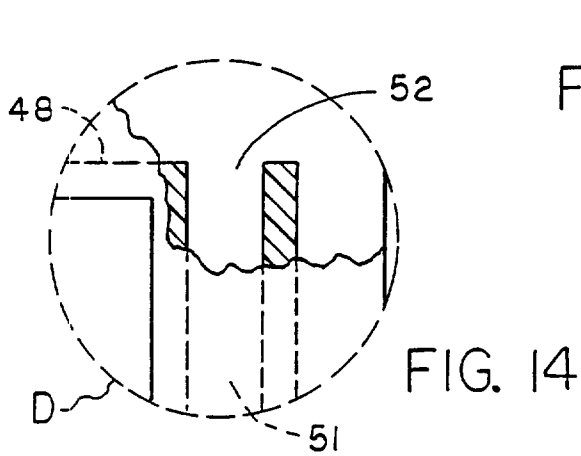
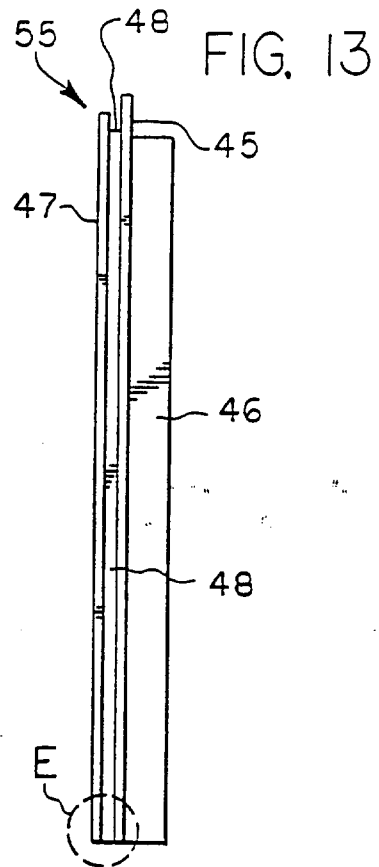
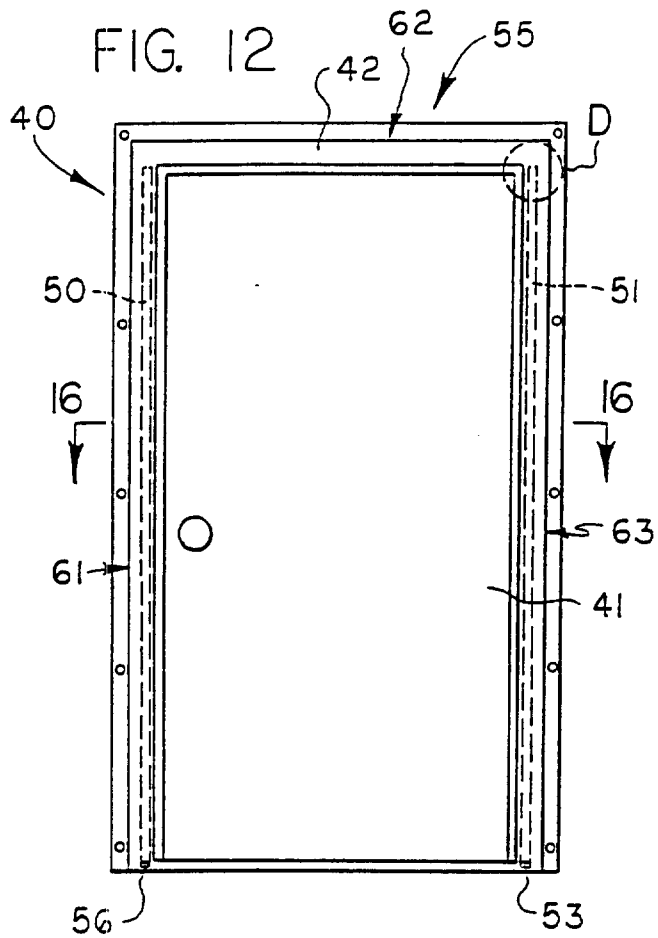

FIG. 9B

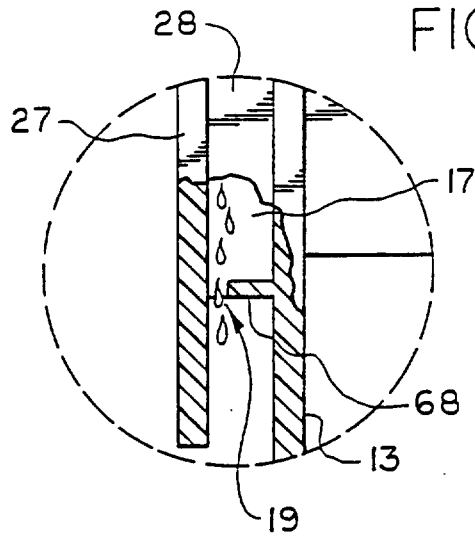

FIG. 15B

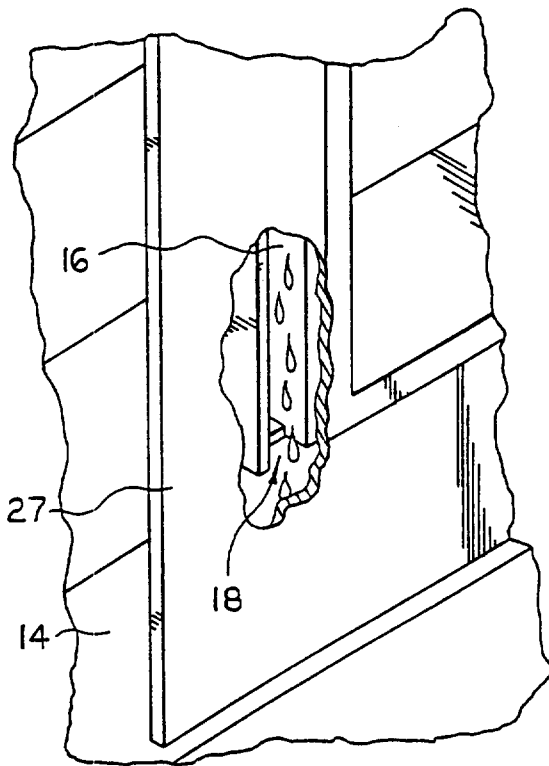
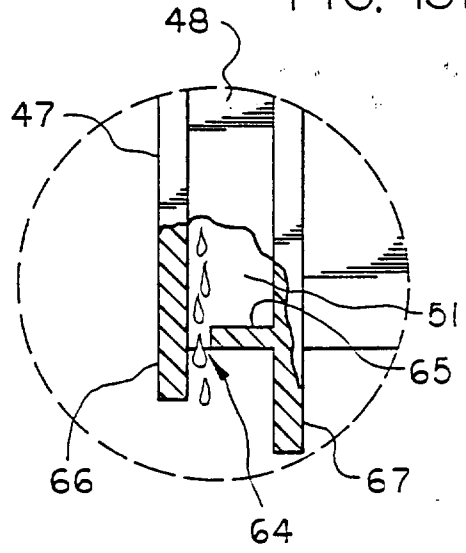

FIG. 17

