

(19) World Intellectual Property Organization
International Bureau



(43) International Publication Date
27 July 2006 (27.07.2006)

PCT

(10) International Publication Number
WO 2006/078314 A2

(51) International Patent Classification:
G01S 7/36 (2006.01) *G01S 7/40* (2006.01)

(21) International Application Number:
PCT/US2005/026049

(22) International Filing Date: 22 July 2005 (22.07.2005)

(25) Filing Language: English

(26) Publication Language: English

(30) Priority Data:
60/590,092 22 July 2004 (22.07.2004) US
11/186,712 21 July 2005 (21.07.2005) US

(71) Applicant and
(72) Inventor: WEBER, Daniel [US/US]; 774 South 1100
West, Cedar City, Utah 84720 (US).

(74) Agents: REED, Carl, T. et al.; Workman Nydegger, 60
East South Temple, 1000 Eagle Gate Tower, Salt Lake City,
Utah 84111 (US).

(81) Designated States (unless otherwise indicated, for every
kind of national protection available): AE, AG, AL, AM,

AT, AU, AZ, BA, BB, BG, BR, BW, BY, BZ, CA, CH, CN,
CO, CR, CU, CZ, DE, DK, DM, DZ, EC, EE, EG, ES, FI,
GB, GD, GE, GH, GM, HR, HU, ID, IL, IN, IS, JP, KE,
KG, KM, KP, KR, KZ, LC, LK, LR, LS, LT, LU, LV, MA,
MD, MG, MK, MN, MW, MX, MZ, NA, NG, NI, NO, NZ,
OM, PG, PH, PL, PT, RO, RU, SC, SD, SE, SG, SK, SL,
SM, SY, TJ, TM, TN, TR, TT, TZ, UA, UG, US, UZ, VC,
VN, YU, ZA, ZM, ZW.

(84) Designated States (unless otherwise indicated, for every
kind of regional protection available): ARIPO (BW, GH,
GM, KE, LS, MW, MZ, NA, SD, SL, SZ, TZ, UG, ZM,
ZW), Eurasian (AM, AZ, BY, KG, KZ, MD, RU, TJ, TM),
European (AT, BE, BG, CH, CY, CZ, DE, DK, EE, ES, FI,
FR, GB, GR, HU, IE, IS, IT, LT, LU, LV, MC, NL, PL, PT,
RO, SE, SI, SK, TR), OAPI (BF, BJ, CF, CG, CI, CM, GA,
GN, GQ, GW, ML, MR, NE, SN, TD, TG).

Published:
— without international search report and to be republished
upon receipt of that report

For two-letter codes and other abbreviations, refer to the "Guidance Notes on Codes and Abbreviations" appearing at the beginning of each regular issue of the PCT Gazette.



WO 2006/078314 A2

(54) Title: SELECTIVE-SAMPLING RECEIVER

(57) Abstract: A receiver that selectively samples a received signal in order to suppress an interference component of the signal while recovering a desired component. The selective sampling may be accomplished by low cost, low complex analog or digital circuitry. The receiver includes a first input that receives a first signal, including a desired signal component and an interference signal component and a second input that receives a second signal including the interference component only. The first and second signals are then provided to the sampling circuitry. First, the phase of the interference component of the both the first and second signals is aligned. Next, the points in a wave cycle that the second signal is at a power minimum are detected. Finally, first signal is sampled close to the point when the second signal is at the power minimum to recover the desired signal component and suppress the interference component.

SELECTIVE-SAMPLING RECEIVER

BACKGROUND OF THE INVENTION

1. The Field of the Invention

The present invention relates generally to receiver systems and methods for
5 interference suppression. More specifically, the present invention relates to a
selective-sampling receiver and methods able to mitigate the interference in received
signals.

2. The Relevant Technology

Transmitting and receiving radio frequency (RF) signals over the airwaves is a
10 vital part of the world today, having wide use in military and commercial
applications. For example, radar systems at an airport send and receive signals that
are used to track airplanes taking off and landing. Radar signals are also used to track
the movement of armed forces on a battlefield or are used to track incoming enemy
missiles or planes. In like manner, cellular phones use an antenna to send and receive
15 voice communication signals.

All systems that receive RF signals, from the hand held cellular phone to the
most complex radar system, include a receiver. The receiver is used to process
signals received from an antenna. For example, the receiver may down convert the
frequency of the received signals or may amplify the received signals. The receiver
20 may also be used to sample portions of the signals. Once the receiver has finished
processing the received signals, the receiver will generally send the signals to other
equipment and systems such as a signal processor for further processing.

However, the signals that are provided to the receiver often are distorted by
various amounts of signal interference. This interference may be from natural causes
25 such as rain or other environmental effects. The interference may also come from
other RF signals that have not been properly isolated from the desired signal. The
interference may even be purposefully added, such as an interference signal from a
radar jamming device used in a military application. Interference can prevent a
receiver from receiving and interpreting desired signals. As a result, the interference
30 must be dealt with by the receiver or the signal provided to the signal processor will
be distorted.

In the past, many techniques have been used to suppress signal interference in

the receiver. Perhaps the most common is the use of a generalized side lobe canceller. The generalized side lobe canceller uses low-gain antennas to isolate the interference signals from a desired signal. Adaptively selected magnitude and phase weights are applied to the interference signals. These weights are then used to estimate the interference component of the desired signal. The estimated interference component is then subtracted out of the desired signal, thus leaving a signal free of most interference.

Another technique that is used in receiver interference suppression is the co-channel interference mitigation in the time-scale domain algorithm. This algorithm uses a wavelet transform to estimate and reconstruct the interference from a null space in the desired signal in the time-scale domain. The estimated interferer is then subtracted from the observations and the remaining signal is an approximation of the desired signals.

These techniques and others in the prior art are able to reasonably suppress signal interference. However, they are very complex and costly. For example, a large number of antenna arrays may be necessary for interference estimates. In addition, the receiver requires costly processing abilities for making the interference estimates and then subtracting them out of the desired signal. The receiver may also need complex circuitry to perform the interference suppression operation. Therefore, what would be advantageous is a low complexity receiver with the ability to suppress interference signals using low cost components.

BRIEF SUMMARY OF THE INVENTION

The forgoing problems with the prior state of the art are overcome by the principles of the present invention, which relate to a receiver with the ability to selectively-sample a received signal in order to suppress an interference signal component of the signal while recovering a desired signal component. The selective-sampling may be accomplished by low cost, low complex analog or digital circuitry. The sampling may also be accomplished by digital algorithms.

The receiver includes a first input that receives a first signal. The first signal includes a desired signal component and an interference signal component. This first signal may be the summation output of a sigma-delta ($\Sigma\Delta$) beam-forming network

The receiver also includes a second input that receives a second signal. The

second signal includes the interference component only. This second signal may be the difference output of a $\Sigma\Delta$ beam-forming network which has subtracted out the desired signal component.

The first and second signals are provided to sampling circuitry. The sampling
5 circuitry, which may be analog or digital circuitry, performs a sampling operation on the signals. First, the phase of the interference component of the both the first and second signals is aligned. Next, the points in a wave cycle that the interference component of the second signal are at a power minimum are detected. Finally, the first signal is sampled as close as possible to the point when the second signal is at the
10 power minimum as the interference component of the first signal will also be at a power minimum. With the interference component at a minimum, only the desired signal component will be sampled. In this way, the desired signal is recovered and the interference signal is suppressed.

Additional features and advantages of the invention will be set forth in the
15 description that follows, and in part will be obvious from the description, or may be learned by the practice of the invention. The features and advantages of the invention may be realized and obtained by means of the instruments and combinations particularly pointed out in the appended claims. These and other features of the present invention will become more fully apparent from the following description and
20 appended claims, or may be learned by the practice of the invention as set forth hereinafter.

BRIEF DESCRIPTION OF THE DRAWINGS

Various embodiments of the present invention will now be discussed with
reference to the appended drawings. It is appreciated that these drawings depict only
25 typical embodiments of the invention and are therefore not to be considered limiting of its scope.

Figure 1A schematically illustrates a ideal selective-sampling receiver in accordance with the principles of the present invention;

Figure 1B schematically illustrates a specific analog embodiment of the
30 selective-sampling receiver of Figure 1A;

Figure 2 illustrates a flowchart of a method for performing a selective-sampling operation;

Figure 3A illustrates a desired signal;

Figure 3B illustrates an interference signal and its power minimums;

Figure 3C illustrates a summation signal of the signals in Figures 3A and 3B;

Figure 4 schematically illustrates a receiver system in which a selective-
5 sampling receiver in accordance with the principles of the present invention may be
implemented;

Figure 5 illustrates interference suppression versus channel isolation for
various angle of arrival;

Figure 6 schematically illustrates multiple selective-sampling receivers
10 implemented in a bank configuration with each cell in the bank having a slightly
different input relationship; and

Figure 7 illustrates squelch performance of a selective-sampling receiver.

DETAILED DESCRIPTION OF THE PREFERRED EMBODIMENTS

The principles of the present invention relate to a receiver with the ability to
15 selectively-sample a received signal in order to suppress an interference signal
component of the signal while recovering a desired signal component. The selective-
sampling may be accomplished by low cost, low complex analog or digital circuitry.
The sampling may also be accomplished by digital algorithms.

The receiver includes a first input that receives a first signal. The first signal
20 includes a desired signal component and an interference signal component. This first
signal may be the summation output of a sigma-delta ($\Sigma\Delta$) beam-forming network

The receiver also includes a second input that receives a second signal. The
second signal includes the interference component only. This second signal may be
the difference output of a $\Sigma\Delta$ beam-forming network which has totally subtracted out
25 the desired signal component.

The first and second signals are provided to sampling circuitry. The sampling
circuitry, which may be analog or digital circuitry, performs a sampling operation on
the signals. First, the phase of the interference component of the both the first and
second signals is aligned. Next, the points in a wave cycle that the interference
30 component of the second signal is at a power minimum are detected. Finally, the first
signal is sampled as close as possible to the point when the second signal is at the
power minimum as the interference component of the first signal will also be at a

power minimum. With the interference component at a minimum, only the desired signal component will be sampled. In this way, the desired signal is recovered and the interference signal is suppressed.

Referring to Figure 1A, an exemplary selective-sampling receiver system 100 in which the principles of the present may be practiced is illustrated. Selective-sampling receiver system 100 is shown by way of illustration only and is not intended to limit the scope of the appended claims. It will become clear to one skilled in the art from reading this specification that there are numerous ways to implement the selective-sampling receiver 100.

10 Selective-sampling receiver 100 includes a first receive input 101 for accessing a first signal 110. First signal 110 may be a sine wave, a square wave, a triangular wave, a pulse or any other periodic waveform at any frequency. Selective-sampling receiver 100 takes advantage of the periodic nature of the input waveform to perform a selective-sampling operation as will be described in more detail below with respect to Figure 2.

15 First signal 110 is comprised of a desired signal component and an interference signal component. First signal 110 may also include other components such as thermal noise. In some embodiments, first signal 110 may be the summation output of a sigma-delta ($\Sigma\Delta$) beam-forming network as will be described in further detail to follow. However, this is not required as first signal 110 may be produced by any means known in the art that combines two or more signal components into a single signal.

20 Selective-sampling receiver 100 also includes a second receive input 102 for accessing a second signal 120. Second signal 120 may also be a sine wave, a square wave, a triangular wave, a pulse or any other periodic waveform at any frequency. Second signal 120 is comprised of an interference signal component and may include other signal components such as thermal noise. In some embodiments, second signal 120 may be the difference output of a $\Sigma\Delta$ beam-forming network as will be described in further detail to follow. However, this is not required as second signal 120 may be produced by any means known to the art.

30 Selective-sampling receiver 100 further includes sampling circuitry 130. Sampling circuitry 130 is configured to selectively sample the first signal 110 so as to

suppress the interference component of the signal and thereby recover the desired signal component. Sampling circuitry 130 may be implemented by numerous different combinations of analog or digital components. Advantageously, the selective-sampling operation may be performed by sampling circuitry 130 components that are low complexity and low cost. It should be noted that selective-sampling receiver 100 may perform the selective-sampling operation on any periodic waveform of any frequency. This includes using the selective-sampling operation in applications such as radar, sonar, and hearing aids. The selective-sampling receiver and the selective-sampling operation should not be construed to only apply to high frequency applications.

For example, sampling circuitry 130 may include delay circuitry 131 for aligning the phase of the interference component of both the first signal 110 and the second signal 120. Zero-crossing detector circuitry 132 may be used to detect the power minimums of the interference components during a wave cycle. Sample-hold circuitry 133 may be used to sample the first signal 110 at the proper time. In Figure 1, sample-hold circuitry 133 is depicted as a switch that closes whenever zero-crossing detector 132 detects a power minimum. Sampling circuitry 130 may also include other components such as inverters, amplifiers for signal amplification, resistors, filters, and the like. As mentioned, there are numerous circuit component implementations of selective-sampling circuitry 130.

Figure 1B illustrates a specific analog implementation of selective-sampling receiver 100. This specific implementation is by way of example only, and should not be read to limit the claims. As mentioned previously, one skilled in the art will appreciate that there are numerous different circuit implementations of selective-sampling receiver 100. As will be obvious from Figure 1B, all of the components of the specific analog implementation of selective-sampling receiver 100 are low complexity, low cost consumer electronic components that may be easy implemented.

Specific analog implementation of selective-sampling receiver 100 includes elements 150A and 150B that may correspond to delay circuitry 131 of Figure 1B and is used to align the phases of the interference components. Diode 160 acts as the zero-crossing detector 132 and the sample-hold circuitry 133. In this example, the diode 160 responds to absolute biasing and produces gain when the second signal is

more negative than the first signal, which is the inverse of the desired relationship. As a result, the first and second signals may be rectified in some embodiments. This occurs during the negative cycle of the waveforms.

Operational-amplifier 161 is used to bias the diode to avoid non-linearity's
5 that might otherwise be produce during sampling. When the magnitude of the first signal is greater than the magnitude of the second signal, which occurs at the power minimums of the second signal, diode 160 will not conduct and resistance in the feedback loop of operational-amplifier 162 will be high. This provides timing for the sampling that effectively blocks the interference component of the first signal and
10 allows gain for the desired signal component from operational amplifiers. Alternatively, when the magnitude of the second signal is greater than the first signal, then diode 160 conducts and a gain of one or unity is added to the signal. Various resistors are also used in this implementation for signal control, by producing a mirror image of the unity gain signal that when added, cancels the unity gain signal out.

15 This circuit may be tuned, if necessary, by attenuating the first signal, thereby decreasing the amount of time that the amplitude of the first signal exceeds the amplitude of the second signal. However, as the first signal is attenuated, the circuit will suffer from decreased signal to noise ratio since noise from the second signal is imprinted on to the output of the circuit. However, the output can be used to trigger
20 the digitalization of the first signal, allowing for reconstruction of the desired signal that is then passed on. As the first signal becomes more attenuated, the timing resolution of the selective-sampling increases.

This circuit may also be used with multipath and/or pulsed signals. The system described above will produce continuous output of a bore-site signal in the
25 absence of any overpowering multipath or jamming signal. This means that the first part of the accessed first signal is passed since it is at bore-site. When a multipath signal is present, the composite signal will tend to pull the desired signal off of bore-site resulting in the squelching of the channel. If necessary, the pulses can be filtered out if needed for a specific application.

30 As has been mentioned, the selective-sampling receiver 100 is configured to perform a selective-sampling operation using the selective-sampling circuitry 130 for the digital implementation. The selective sampling operation may also be performed

by a digital algorithm. Referring to Figure 2, a method 200 for a selective-sampling receiver to perform the selective-sampling operation is described. The method 200 will be discussed with reference to the selective-sampling receiver of Figure 1. The selective-sampling receiver accesses a first signal comprising a desired signal component and an interference component (201) and accesses a second signal, either
5 from an external source or an internal source, comprising an interference component (202). As can be seen in Figure 2, the order that the selective-sampling receiver accesses the two signals is unimportant to the principles of the present invention, although in many embodiments the two signals will be accessed or received
10 simultaneously.

Selective-sampling circuitry in the selective-sampling receiver, such as delay circuitry 131, aligns the phase of the interference component of both the first and second signals (203). The selective-sampling receiver takes advantage of the fact that the interference component of the first signal may lead or lag the interference
15 component of the second signal by a phase of 90 degrees in some embodiments. By delaying either the first or the second signal by 90 degrees, the phase of the interference components in both the first or second signal should be aligned.

The selective-sampling circuitry then determines when the interference component in the second signal is at a power minimum during a wave cycle (204).
20 As the first and second signals are usually periodic, they will have predictable power minimums or zero crossing points. For example, a sine wave has two power minimums or zero crossing points per wave cycle, which is referred to the Nyquist sampling rate. The selective-sampling circuitry, such as zero-crossing detector 132, detects when the second signal has the power minimums. Since the interference
25 components of the first and second signals are aligned, the interference component of the first signal will be at a power minimum whenever the second signal is at a power minimum.

The selective-sampling circuitry samples the first signal as close as possible to the point in time that the second signal is at a power minimum (205). The sampling
30 may be accomplished by the sample-hold circuitry 133 of Figure 1A. As mentioned previously, the interference components of both the first and second signals will be at a power minimum at the same time when their phases are aligned. Consequently,

only the desired signal component and perhaps a noise component of the first signal will remain to be sampled if the sampling occurs during the power minimum of the second signal. As a result, any signal that is reconstructed from the sampling will be very close to the desired signal. As long as the sampling is performed at least at the
5 Nyquist sampling rate of the first signal, then a reasonable desired signal may be reconstructed. The reconstructed signal may then be provided by the selective-sampling receiver to other instruments, such as a signal processor in a radar system, for further use and analysis.

Advantageously, the selective-sampling method just described suppresses the
10 unwanted interference signal component and recovers the desired signal component without the need for time consuming calculations to determine interference estimates and then to subtract them from the desired signal. In addition, since the selective-sampling receiver derives when to sample from the power minimums of the interference signal component in real time, it is able to respond to changes in the
15 interference environment almost instantaneously.

A specific example of the selective-sampling operation will now be described with reference to Figures 3A, 3B and 3C. In Figure 3A, a 450 degree portion of a desired signal 302 at bore-sight is shown. A bore-sight signal is one that is directly in front of an antenna and has maximum power. The desired signal has a 360 degree
20 cycle and has power maximums around 135 degrees and 315 degrees. The amplitude at these points is between 0 and 0.1768 in this example.

Figure 3B depicts a 450 degree portion of an interference signal 304. The interference signal has power maximums around 90 and 270 degrees, which have amplitude of around 1 and, in this example, power minimums at 0 and 180 degrees.
25 There is also a power minimum at 360 degrees, which is the start of a new wave cycle. Note that during the 450 degrees that are shown, the magnitude of the interference signal 304 is much greater than the magnitude of the desired bore-sight signal 302 and would thus dominate the desired signal 302.

Figure 3C depicts a signal 306 that is a summation of the desired signal 302
30 and the interference signal 304. This may represent the first signal of Figure 1A. As can be seen, the magnitude of the summation signal 306 is close to the magnitude of the interference component as the interference component dominates the signal.

Figure 3C also shows sampling points A, B, and C. Sampling point A corresponds to the power minimum of the interference component at 0 degrees, sampling point B corresponds to the power minimum at 180 degrees, and sampling point C corresponds to the power minimum at 360 degrees.

5 When the summation signal is sampled as close as possible to the summation points, the desired signal may be recovered. The recovered signal is depicted by the dashed line 308 in Figure 3C. As can be seen, the recovered signal (dashed line 308) closely mirrors the original desired signal 302 of Figure 3A.

10 Referring to Figure 4, a two channel receiver system 400 in which a selective-sampling receiver in accordance with the present invention may be implemented is illustrated and will now be described. Receiver system 400 includes antenna and steering section 410, a $\Sigma\Delta$ beam-former 420, a selective-sampling receiver 430, and a quadrature down converter 440.

15 Antenna and steering section 410 includes two antenna elements 411A and 411B that are used to measure two signals. Antennas 411 may be any antenna known in the art, such as for example a monopulse antenna array. For example, antenna 411A may be used to measure a signal containing both the desired signal and the interference signal while antenna 411B is used to receive the same signal, but at a different phase angle. The measured signals are passed through band pass filters 412A
20 and 412B, which are used to filter out unwanted signal bands and may be any filter known in the art. The filtered signals are then steered by steering networks 413A and 413B, which may be any known steering network in the art, to the inputs of $\Sigma\Delta$ beam-former 420. In the depicted example, steering network 413A is used to steer one of the measured signals to the bore-sight angle of arrival, while steering network 413B is
25 used to steer the other measured signal to some off bore-sight angle of arrival.

 The $\Sigma\Delta$ beam-former 420, which may be any $\Sigma\Delta$ beam-former known in the art, has a summation channel 422 and a difference channel 421. The summation channel 422 produces a first signal which is a composite sum of the desired signal component and the interference signal component. On the other hand, the difference
30 channel 421 produces a second signal where one-half of the received signal is subtracted from the other half. However, when the second signal is at bore-site, the desired signal component is phased out, thus leaving only the difference component in

the second signal.

The first and second signals are then provided to selective-sampling receiver 430, which may correspond to selective-sampling receiver 100 of Figure 1A. However, Figure 4 depicts an alternative embodiment of the selective-sampling receiver. In this embodiment, both an in-phase and quadrature component of the first signal will be sampled. To preserve all signal information in some instances, it may be necessary to selectively sample both the in-phase and quadrature components of the first signal. This helps to prevent loss of signal information and minimize distortion produced in the analog reconstruction process. The sampling circuitry components of selective-sampling receiver 430 will be the same or similar to those described above in relation to selective sampling receiver 100.

For the in-phase sampling, the second signal passes through delay circuitry 431, where it is delayed in order to align its phase with the interference component of the first signal in the manner previously described. The zero-crossing detector circuitry 432 then detects when the second signal is at a power minimum during a wave cycle. The sample-hold circuitry 433 then samples the first signal, producing a signal that suppresses the interference and recovers the desired signal.

For the quadrature sampling, the first signal is passed through an impedance inverter 435, which creates a quadrature component of the first signal. The second signal is passed through circuitry 438, which creates a quadrature component of the second signal and aligns the phases of the signals. The zero-crossing detector 436 detects when the quadrature second signal is at a power minimum during a wave cycle. The sample-hold circuitry 437 then samples the quadrature first signal, producing a signal that suppresses the interference and recovers the desired signal.

Both the in-phase and quadrature sampled signals are then passed to quadrature downconverter 440. Both signals pass through low-pass filters 440A and 440B in order to remove harmonic content introduced in the sampling operation. Some local oscillation 441 is mixed by mixers 443A and 443B with the in-phase and quadrature signals respectively, the local oscillation having been converted to quadrature by impedance inverter 441 before the mixing. Finally, the adder circuitry 445 combines the in-phase and quadrature signals to reconstruct the desired signal.

The two channel receiver system just described suppresses interference

without the need for complex circuitry. Cross talk between the summation and difference channels in the $\Sigma\Delta$ beam-former, however, may limited the suppression of the interference. However, providing isolation for the two channels helps to overcome this problem. The isolation may be accomplished by any isolation
5 technique known to one skilled in the art. Figure 5 shows interference suppression versus the angle of arrival of the interference signal for various levels of isolation in the beam-former. For example, curve 501 illustrates interference suppression for 20 dB of isolation, curve 502 illustrates interference suppression for 30 dB of isolation, curve 503 illustrates interference suppression for 40 dB of isolation, curve 504
10 illustrates interference suppression for 50 dB of isolation, and curve 505 illustrates interference suppression for 60 dB of isolation. In some embodiments, the selective-sampling receiver 100 may be utilized in a bank of multiple selective-sampling receivers. This is done to increase the field of view that may be monitored by a system implementing the selective-sampling receivers as the measured azimuth and
15 elevation angles are increased. This is illustrated in Figure 6, which depicts a bank 601 of 16 selective-sampling receivers or filters. In this embodiment, the first signal comprising the interference and desired signal components is still measured at bore-sight as in the two channel case and is provided to all 16 selective-sampling receivers. The second signal consisting of the interference signal, however, is shifted for every
20 selective-sampling receiver, 1 degree in the depicted example, such that the interference component is slightly different for each receiver. The sampling operation will still be performed as described previously, i.e. the first signal will be sampled when the interference component of the second signal is at a power minimum.

The selective-sampling receiver also may be implemented in a system that
25 uses a sub-array to measure an antenna beam. In this case, only the even side lobes will have a receiver in-lobe condition. As a result, a squelch region will be provided for the odd side lobe energy. In addition, a squelch region is produced and there is no output when the delta input is of a greater value than the attenuated sum input. This can be seen in Figure 7. In Figure 7, the main beam 701 shown with the squelched
30 lobe 702. This embodiment may be useful in preventing interference from electronic counter measures that often time enter the main lobe from the side lobes.

The selective-sampling receiver and selective-sampling method described with

relation to Figures 1A, 2, and 4 above are useful in counter-counter measure systems that are used to block electronic counter measures and tracking systems that are used to suppress decoy signals. In particular, the ability of the selective-sampling receiver to adjust almost instantaneously to a change in the interference environment can be helpful in a situation where a radar jamming signal is present in order to prevent a target from being seen. This ability is also helpful to discriminate between a target and a decoy, for example an airplane using radar, a ship using sonar or submarine pulling a decoy to deflect detection by radar or sonar.

The selective-sampling receiver and selective-sampling method described with relation to Figures 1A, 2, and 4 above may be utilized in many medical applications. For example, the selective sampling receiver may be used in ultrasound systems. An ultrasound transducer is a series of piezoelectric transducers placed in parallel with each other. As a sound pulse is sent out it travels at the speed of sound until it hits something such as soft tissue. It then reflects some of the energy, which is picked up by the ultrasound transducer. Each piezoelectric sensor picks up some of this received energy and a computer processing an image is formed. The selective sampling receiver helps to focus the received energy for better imaging.

Likewise MRI systems pickup radio frequency energy in order to form its image. When water atoms are placed in a strong magnetic field the atoms align to the same orientation. When this water is pulsed with RF energy, the atoms shift alignment to respond to the RF pulse similar to a microwave oven. When the RF energy stops, the water realigns to the magnetic field and in the process releases RF energy as well. This energy is read and an image is formed. Different densities of water release different amounts of RF energy which look different on the final image. The selective sampling receiver is capable of focusing in on smaller areas of interest or increase the resolution in troughs areas. In addition, since more than one thing can be seen at the same time in the same field of view higher resolution images are possible.

The selective sampling receiver may also be used in hearing aids and other such devices. In a hearing aid or other repeater applications, the second signal may be produced by the system itself. This means that the information that is obtained from the second signal discussed previously (i.e., when to sample and the zero-crossing

point of the second signal) can be predicted by the system. As a result, only a first signal containing both an interference and desired signal component is actually accessed or received by the hearing aid. However, since the zero-crossing point is predicted for the interference component, the desired component is sampled as previously discussed and the desired signal can be produced.

The selective-sampling receiver and selective-sampling method described with relation to Figures 1A, 2, and 4 above may also be utilized in communications networks. Because the selective sampling receiver has the ability to suppress unwanted signals, two satellites or communication towers may be in close proximity to each other and transmit using the same frequencies. Since each satellite or communication tower will have its own selective sampling receiver, the amount of data that may be transmitted is increased as each satellite or communication tower will suppress unwanted signals from the other satellite or tower.

Accordingly, the principles of the present invention relate to a selective-sampling receiver and method. The selective-sampling receiver utilizes low complexity, low cost components to achieve a high level of interference signal suppression. This removes the need for expensive hardware to be used in interference suppression. In addition, the need for complex processing capabilities is also removed. Accordingly, the principles of the present invention are a significant advancement in the art.

In order to find the right time to sample a signal that is made up of more than one component (a desired signal and at least one interference signal) resulting in the separation of one of the components, antennas can be used to pick up patterns that have nulls. The desired signal is placed in this null in the antenna or an antenna network pattern meaning that this antenna has no input from the desired signal. A second antenna or antenna network will have the desired signal in its antenna pattern along with the interferer.

One such system is a monopulse antenna array. Two antennas create this antenna network. Two channels are created; one is called the sum channel since antenna elements A and B are added up in it. The second channel is called the Delta channel since one half of the received signal is subtracted from the other half. For example input A is subtracted from input B. A-B and the radio frequency pickup

patterns as compared to angle of approach of RF energy can be determined. A signal that is at bore-site (directly in front of the antenna array) has maximum input in the Sum channel. But since the inputs are matches in all antenna pickups, the delta channel has no pick up of the signal since antenna A completely subtracted from
5 antenna B.

Now using the delta channel that has only the interferer signal, the point in time to sample the sum channel that has the interferer and the desired signal can be determined.

In one embodiment, a satellite dish Gain of the desired signal from competing
10 satellites is 10-20 dB. In the selective sampling receiver this separation in amplitude isn't created with satellite dish gain but in interference suppression ending with an equal amount of amplitude difference in the final product. Two satellites can now exist in close proximity operating on the same frequency and not interfere with one another using embodiments of the invention. Advantageously, the data throughput
15 may be doubled when dealing with properly designed system utilizing embodiments of invention described herein.

Embodiments of the invention can be used with any type of waveform (sine, square, triangle, pulse, etc.) and any transmission medium (air, water, electromagnetic, etc.) to detect energy levels of these waveforms. Sampling can be
20 accomplished during the representative power levels taken from the waveform.

With repetitive sampling of a waveform, the waveform can be converted into a steady power level. This may included multipath signals although the exact power level may not be known. Fluctuating power levels may be due to background signals that are not synced to the detected or predicted waveform and resulting sampling
25 points. Separation of these fluctuating levels can be done mathematically or with a filter such as a capacitor. When a waveform is held to a steady power level, weaker waveforms can be detected and received. Alternatively, known or sampled/detected sources of interference can be sampled such that they do not appear in the final sampled output.

30 By sampling as discussed herein, a signal can be produced that is suppressed. This allows for the same frequency to be used for both receiving and transmissions. this may be used, by way of example and not limitation, in repeaters and hearing aids.

When sampling is accomplished, it is preferably done at twice the primary frequency or twice the intermediate frequency or twice the received frequency. this is above the Nyquist sampling rate. Further, embodiments of the invention can quickly respond to changes in the interfering signal since it is one half of the received wavelength.

5 Placing the signal of interest or the desired signal into an amplitude null on an antenna or an antenna array or other device or system which produces a receiving/pickup signal, the undesired signals can be minimized for a minimum or constant or known energy point at which sampling is accomplished. In one embodiment, the signal of interest and the undesired signal are offset in the pickup
10 system such that the undesired signal is present and the desired signal is not.

 After analyzing the undesired signal or signals for the proper timing, which is preferably located at the minimum energy points or an known or constant energy points. In some embodiments, a phase delay may be needed in order to accomplish sampling at the same point of time when referring to the phase of the undesired
15 signals.

 In one embodiment, to avoid the un-uniformed multiple signal addition of the undesired signal that occurs when producing an antenna's null as compared to an omni directional antenna's addition of the same signals coming from different angles of approach, a purely null or delta antenna system pickup system can be used. In such
20 a system, the signal of interest is placed into the true null for interference analyzing. the signal of interest is then sampled out of the two null channels that are offset from the signal of interest in opposite directions or orientations when compared to the graphed null pickup patterns. The output of these two pickups is full wave rectified or changed to an absolute value and added. The provides for a suppressed, but present
25 signal of interest and a uniformed pickup pattern for the signal of interest and the interfering signals that are analyzed in the true delta pickup pattern, except close to boresight or the center of the dual delta pickup patterns. This eliminates the ambiguities that form from using unlike system channels that have different pickup patterns.

30 Sinusoidal thermal noise signals can also be suppressed due to the same signals being used throughout with small delays added to provide for different angles of approach. As the channels are compared to each other they will be similar and the

point of suppression for this noise can be found. As a result the system signal to noise should at least remain constant as it passes through the system.

One embodiment uses the angle of approach to isolate the signal of interest and such systems are inherently directional. When enough energy is received from
5 phase analyses for the unwanted signal, the unwanted signal will be suppressed from off null angles of approach. This allows for added angle accuracy to be achieved.

A analog or digital algorithm that compares received levels from different channels such as a sum and difference channels of a mono-pulse receiver system where the signal of interest is placed in a null so that when this channel passes
10 through its zero crossing the sum channel is sampled.

A bank of analog circuits/digital algorithms where the input to each cell in the bank is formed to represent a different angle of approach resulting in a wide field of view. Multiple returns are processed in a parallel process of evaluation allowing for faster evaluation of the received wave front.

15 Counter-counter measure systems may utilize large energy returns (jamming of interference) or numerous radio echoes (balloon or decoys). Because one embodiment of the invention uses an operational amplifier, a diode and a few resistors, it is less likely to be affected by high energy particles as found in space that will damage large integrated circuits such as signal processors. This analog
20 suppression of the unwanted signals and reception of wanted signals can be performed fast.

Tuning of such an analog system in regards to sensitivity to angle of approach is accomplished by attenuation of the channel in which the desired and undesired signals are placed. Now when the amplitudes are compared in the two channels the
25 desired signal should be larger in order to come out of the comparator. Signal to noise degradation can be overcome if sampling is done from the un-attenuated channel before it is attenuated.

A receiver can take advantage more than one transmitter in the antennas field of view but use the tuning to separate out the different transmitters. This can allow
30 for more than one satellite to be in a satellite receivers/dishes field of view and yet have the receiver choose which transmitted signal to pass on for processing.

When one embodiment of the system is tuned, the signal output may be either

a sinusoidal signal if the signal of interest is in it or noise if the signal of interest is not in it or is too small to overcome the noise floor.

In one embodiment, it is possible to squelch out unwanted signals by manipulating the pickup patterns so that the desired angle of approach is passed but unwanted or undesired angles of approach are squelched. This is accomplished by overlapping the pickup patterns such as arrays of different sizes such as a full size into the sum input and half the size into the delta input in a mono-pulse system. As a result the odd sidelobe are squelched.

In pulse systems or spread spectrum systems this approach can be used and the need for very accurate timing systems eliminated. This is done by utilizing the angle of approach. The first signal will pass from the angle of interest but multi-paths come from different angles of approach that will pull the received signal out of the angle bin being used. As a result the first leading pulse will be passed and other paths can squelch the channel.

The present invention may be embodied in other specific forms without departing from its spirit or essential characteristics. The described embodiments are to be considered in all respects only as illustrative and not restrictive. The scope of the invention is, therefore, indicated by the appended claims rather than by the foregoing description. All changes which come within the meaning and range of equivalency of the claims are to be embraced within their scope.

CLAIMS

What is claimed is:

1. A receiver system for selectively sampling a signal with two or more signal components, the receiver comprising:
 - 5 a first receive input for accessing a first signal, the first signal comprising a first desired signal component and an interference signal component;
 - a second receive input for accessing a second signal, the second signal composed of the interference signal component;
 - sampling circuitry coupled to the first and second receive inputs;
 - 10 wherein the sampling circuitry selectively samples the first signal by:
 - aligning the phase of the interference components of the first and second signals;
 - detecting when the interference component of the second signal is at a power minimum during a wave cycle; and
 - 15 sampling the first signal close to the points when the second signal is at a power minimum so as to recover the first desired signal component and suppress the interference signal component.
2. A receiver system in accordance with Claim 1 further comprising:
 - 20 at least two antenna elements configured to measure a desired signal and an interference signal;
 - a beam steering network configured to steer the desired signal near bore-site and the interference signal off bore-site; and
 - a beam-forming network coupled to the beam steering network configured to produce a first signal comprising the sum of the desired signal and the interference
 - 25 signal, thereby producing a first signal with a desired and interference component, and a second signal comprising the difference of the interference signal and the desired signal, wherein at bore-site the desired signal is phased out leaving only the interference component, and configured to provide the first and second signals to the receiver system.
3. A receiver system in accordance with Claim 1 further comprising:
 - 30 sampling circuitry configured to produce a quadrature signal; and

a quadrature downconverter coupled to the sampling circuitry configured to down convert an in-phase and quadrature signal.

4. A receiver system in accordance with Claim 1, wherein the first and second signals are one of a sine wave, a square wave, a triangular wave, a pulse, or
5 any periodic waveform.

5. A receiver system in accordance with Claim 1, wherein the sampling circuitry includes analog zero-crossing detectors, inverters, amplifiers, diodes, resistors and filters.

6. A receiver system in accordance with Claim 1, wherein the sampling
10 circuitry is comprised of digital circuit components.

7. A receiver system in accordance with Claim 1 further comprising:
a third receiver input for accessing the first signal;
a fourth receive input for accessing a third signal, the third signal comprising
an interference signal having a different phase than the second signal;

15 sampling circuitry coupled to the third and fourth receive inputs;
wherein the sampling circuitry selectively samples the first signal by:

aligning the phase of the interference component of the first and third
signals;

20 detecting when the third signal is at a power minimum during a wave
cycle; and

sampling the first signal close to the points when the third signal is at a
power minimum so as to recover the desired signal component and suppress
the interference signal component of the first signal so as to increase the field
of view that may be monitored by the receiver system.

25 8. A receiver system in accordance with Claim 1, wherein the receiver
system is used in a counter-counter measure system to block electronic counter
measures. This includes any form of jamming whether accidental or intentional.

9. A receiver system in accordance with Claim 1, wherein the receiver
system is used in a tracking system to suppress decoy signals.

30 10. A receiver system in accordance with Claim 1, wherein a squelch
region is produced when the second signal is greater than the first signal.

11. A method for a receiver system to selectively sample a signal so as to suppress an interference component of the signal, the method comprising;
- accessing a first signal, wherein the first signal comprises a desired signal component and an interference signal component;
 - 5 accessing a second signal, either from an external source or from an internal source, wherein the second signal is comprised of only an interference component;
 - aligning the phase of the interference components of both the first and second signals;
 - determining when the interference component of the second signal is at a
 - 10 power minimum during a wave cycle; and
 - sampling the first signal close to the points when the second signal is at a power minimum so as to recover the desired signal component and suppress the interference signal component.
12. A method in accordance with Claim 11 further comprising:
- 15 measuring a desired signal and an interference signal;
 - beam steering the desired signal near bore-site and the interference signal to off bore-site;
 - beam-forming the desired signal and the interference to produce a first signal comprising the sum of the desired signal and the interference signal, thereby
 - 20 producing a first signal with a desired and interference component, and a second signal comprising the difference of the interference signal and the desired signal, wherein at bore-site the desired signal is phased out leaving only the interference component; and
 - providing the first and second signals to the receiver system.
- 25 13. A method in accordance with Claim 11, wherein the first and second signals are one of a sine wave, a square wave, a triangular wave, a pulse, or any periodic waveform.
14. A method in accordance with Claim 11, wherein sampling is accomplished by analog circuitry.
- 30 15. A method in accordance with Claim 11, wherein sampling is accomplished by digital circuitry or algorithms
16. A method in accordance with Claim 11, wherein an algorithm is used.

17. A method in accordance with Claim 11, wherein the receiver system adjusts in real time to changes in an interference environment.

18. A method in accordance with Claim 11, wherein sampling is performed at least at the Nyquist sampling rate.

5 19. A method in accordance with Claim 11, wherein the sampling method is used in a counter-counter measure system to block electronic counter measures or in a tracking system to suppress decoy signals.

20. A method in accordance with Claim 11, wherein the selective sampling receiver is used in medical applications including an ultrasound, a hearing aid, and a
10 magnetic resonance imaging (MRI) device.

21. A method in accordance with Claim 11, wherein the selective sampling receiver is used in communication applications.

22. In a receiver system including a first signal, wherein the first signal comprises a desired signal component and an interference signal component, and a
15 second signal, wherein the second signal is comprised of an interference signal component, a method for the receiver system to selectively-sample the first signal so as to suppress the interference signal component and recover the desired signal component, the method comprising;

a step for selectively-sampling the first signal.

20 23. A method in accordance with Claim 22, wherein the step for selectively sampling the first signal comprises the following:

aligning the phase of the interference component of both the first and second signals;

determining when the interference component of the second signal is at a
25 power minimum during a wave cycle; and

using the power minimum points of the second signal to trigger sampling of the first signal.

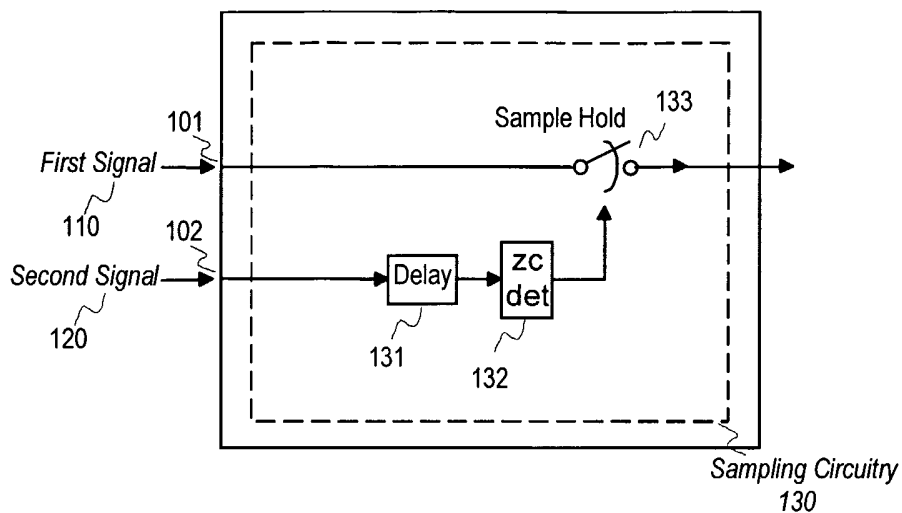

Figure 1A

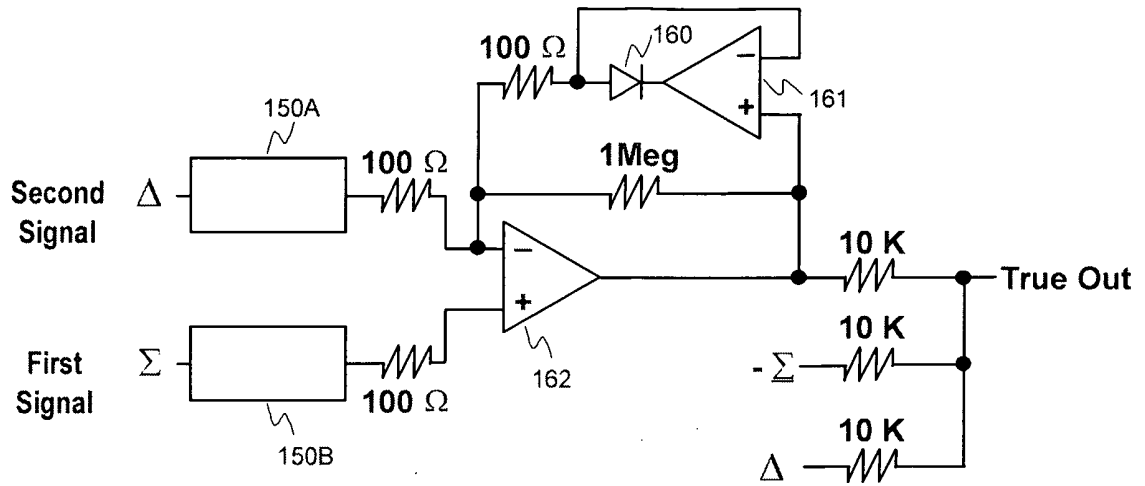

Figure 1B

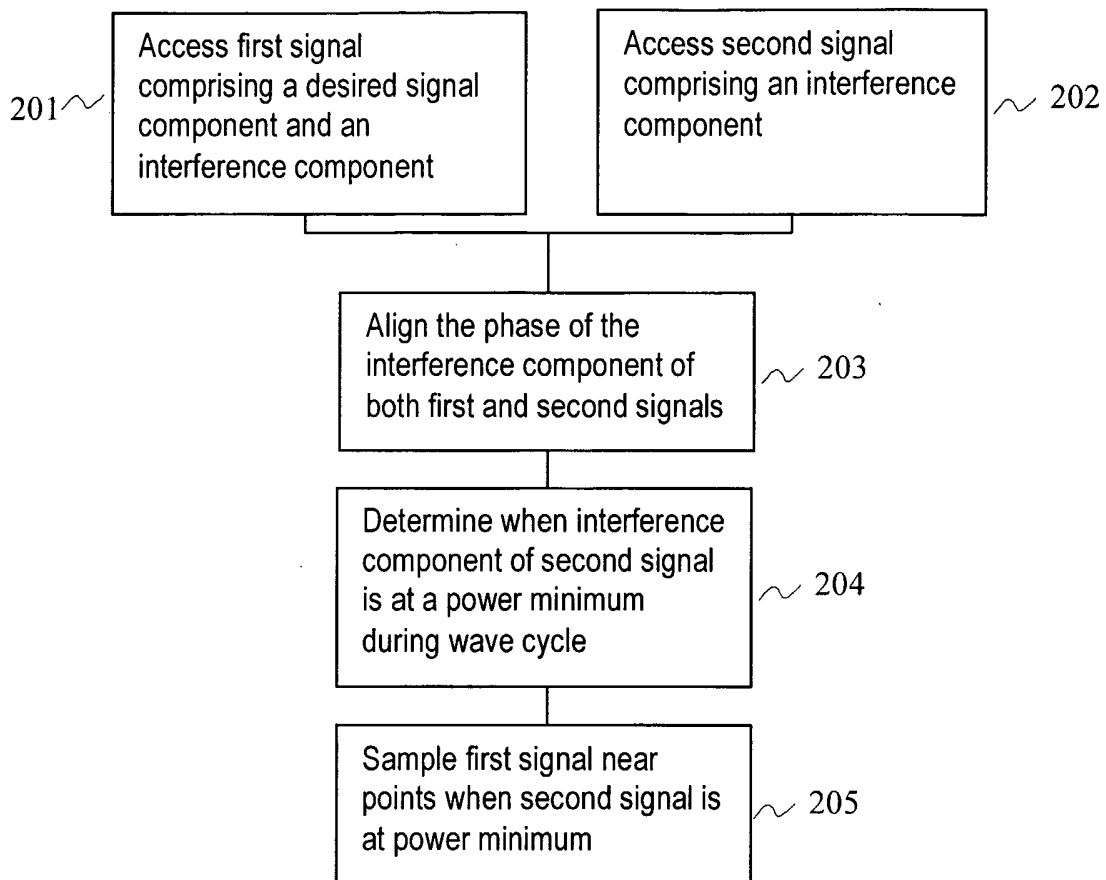

Figure 2

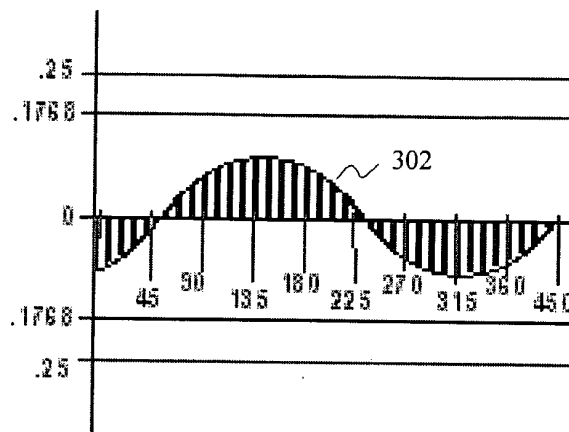

Figure 3A

5/10

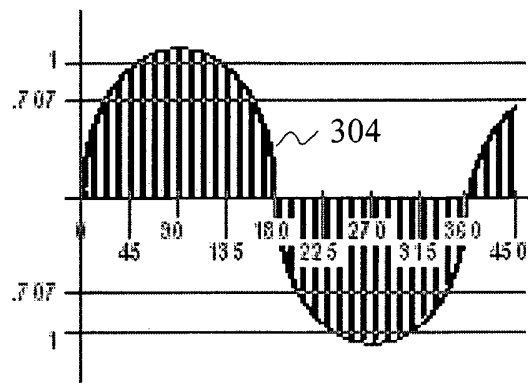

Figure 3B

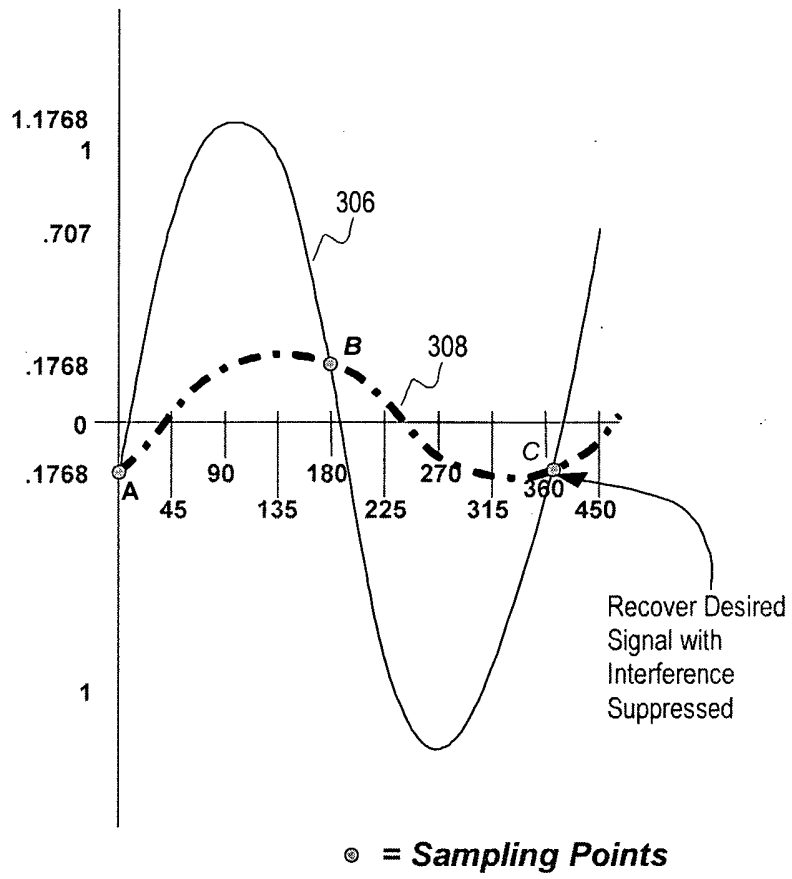

Figure 3C

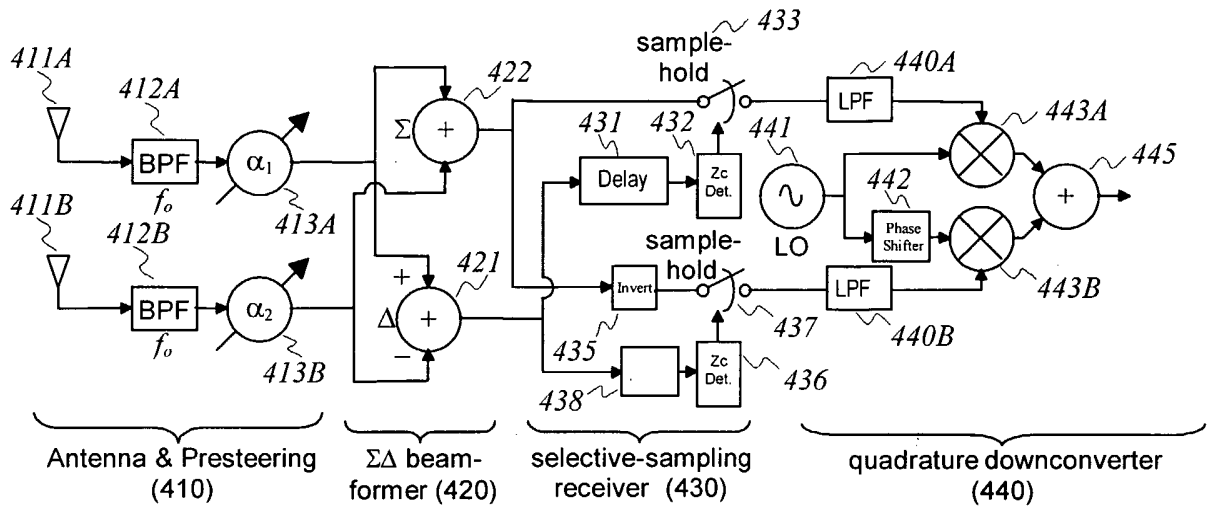

Figure 4

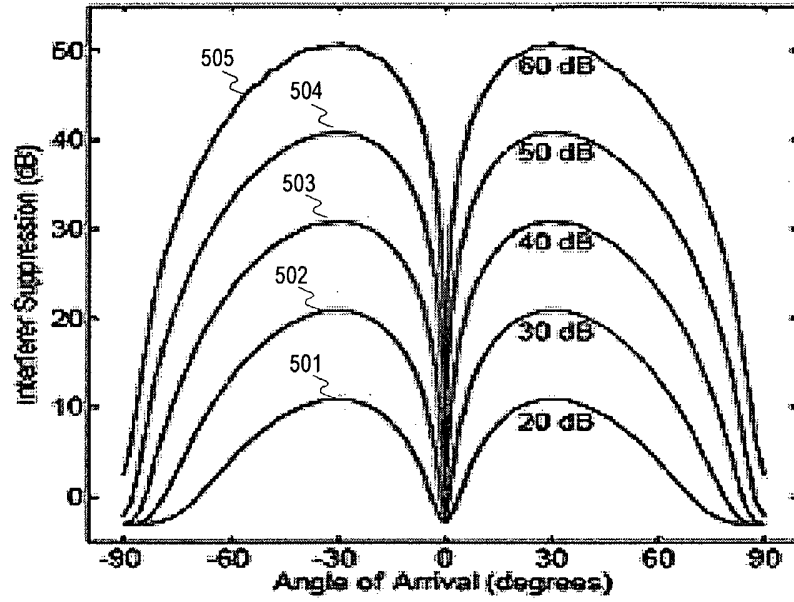

Figure 5

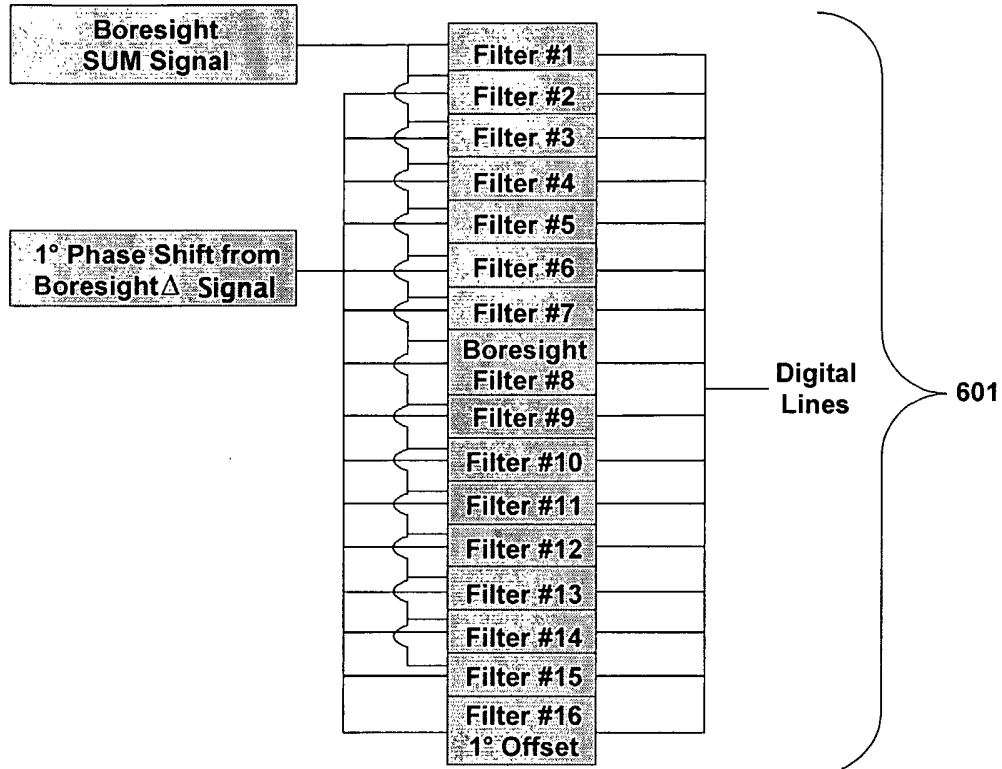

Figure 6

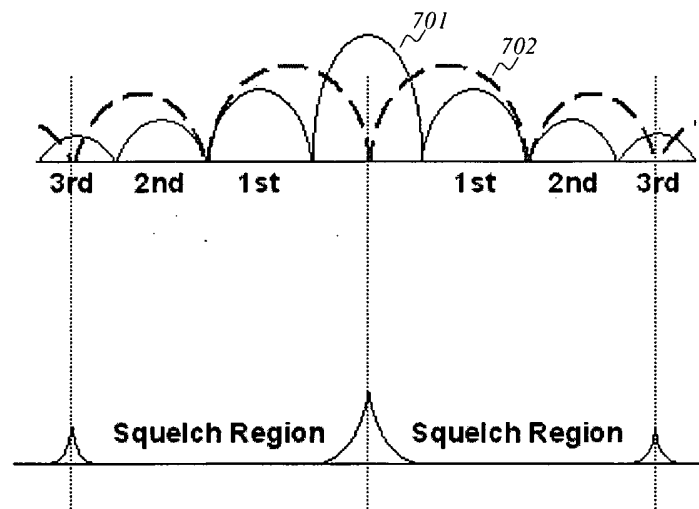

Figure 7