

(19) World Intellectual Property Organization
International Bureau



(43) International Publication Date
20 September 2001 (20.09.2001)

PCT

(10) International Publication Number
WO 01/69480 A1

(51) International Patent Classification⁷: **G06F 17/60**

DE, DK, DM, DZ, EE, ES, FI, GB, GD, GE, GH, GM, HR, HU, ID, IL, IN, IS, JP, KE, KG, KP, KZ, LC, LK, LR, LS, LT, LU, LV, MA, MD, MG, MK, MN, MW, MX, MZ, NO, NZ, PL, PT, RO, RU, SD, SE, SG, SI, SK, SL, TJ, TM, TR, TT, TZ, UA, UG, US, UZ, VN, YU, ZA, ZW.

(21) International Application Number: PCT/KR01/00392

(22) International Filing Date: 13 March 2001 (13.03.2001)

(25) Filing Language: Korean

(84) Designated States (regional): ARIPO patent (GH, GM, KE, LS, MW, MZ, SD, SL, SZ, TZ, UG, ZW), Eurasian patent (AM, AZ, BY, KG, KZ, MD, RU, TJ, TM), European patent (AT, BE, CH, CY, DE, DK, ES, FI, FR, GB, GR, IE, IT, LU, MC, NL, PT, SE, TR), OAPI patent (BF, BJ, CF, CG, CI, CM, GA, GN, GW, ML, MR, NE, SN, TD, TG).

(26) Publication Language: English

(30) Priority Data:
2000/12458 13 March 2000 (13.03.2000) KR

(71) Applicant and

(72) Inventor: **CHO, Do-won** [KR/KR]; 968-44, Bongchon 1-Dong, Kwanak-ku, Seoul 151-821 (KR).

Published:

- with international search report
- before the expiration of the time limit for amending the claims and to be republished in the event of receipt of amendments

(74) Agents: **RYU, Chang-hee** et al.; Rm 405, Hyundai Insurance B/D, 649-14, Yeoksam-Dong, Kangnam-ku, Seoul 135-080 (KR).

(81) Designated States (national): AE, AG, AL, AM, AT, AU, AZ, BA, BB, BG, BR, BY, BZ, CA, CH, CN, CR, CU, CZ,

For two-letter codes and other abbreviations, refer to the "Guidance Notes on Codes and Abbreviations" appearing at the beginning of each regular issue of the PCT Gazette.

(54) Title: A COMPUTER ADVERTISEMENT METHOD USING AN ADVERTISEMENT DEDICATED PROGRAM

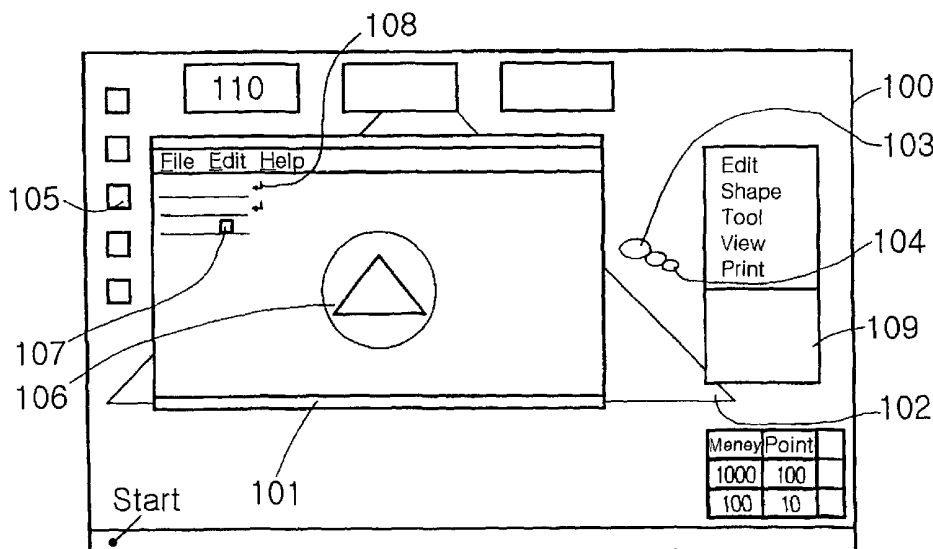

(57) Abstract: A computer advertisement method using an advertisement dedicated program. The advertisement dedicated program (31) is installable in a user computer (30) to integrately manage all expressible advertisements in the computer irrespective of its online or offline connection to an Internet network (20). The user can conveniently select a desired advertisement and receive a predetermined amount of money or points in compensation for viewing the selected advertisement. An advertisement provider can provide the advertisement selected by the user, which is an advertising target, in various forms according to the user's occupation, age, sex and taste, so as to increase the advertising effect. Therefore, this computer advertisement method has the effect of satisfying both the user and advertiser.



WO 01/69480 A1

COMPUTER ADVERTISEMENT METHOD USING AN ADVERTISEMENT DEDICATED PROGRAM

Technical Field

The present invention relates in general to a method for providing
5 advertisements to computers using an advertisement dedicated program, and more particularly to a computer advertisement method using an advertisement dedicated program, wherein the advertisement dedicated program is installable in a user computer to integratedly manage all expressible advertisements irrespective of the user computer's online or offline connection to an Internet network so as to provide the advertisements to
10 the user computer in all possible manners, and a user can conveniently select a desired advertisement and receive a predetermined amount of money or points in compensation for the advertisement selection or use.

Background Art

Recently, personal computers have become widespread in companies and homes
15 and the use of the Internet through the personal computers has rapidly increased nationally and internationally, resulting in an explosive increase in the number of Internet users. In this connection, the Internet and personal computers have been highlighted as new advertising media owing to their use by many persons.

In particular, it was very difficult to provide external advertisements through
20 personal computers, in that most of them were privately used by individuals. However, with popularization of computer communication networks such as Internet networks, recently, many methods have been developed to provide advertisements using communication dedicated programs under the condition that computers are connected to the Internet networks.

25 For example, a site manager establishes an Internet site associated with a server and invites Internet users to access the established Internet site and register themselves as members. Each time Internet users registered as members gain access to the Internet

site and view an advertisement provided in the site, the site manager pays the users a predetermined amount of cash or accumulates a predetermined amount of points or cyber money assigned to the users. An advertiser pays a predetermined advertising fee to the site manager according to a contract with the manager. This example is a representative
5 computer advertisement method.

In such a conventional computer method, box-shaped graphics related to an advertisement, which is a so-called banner advertisement, are displayed on a homepage of a site manager. If a member visitor clicks on the banner advertisement using a mouse, then he or she is linked to an Internet site of an advertiser associated with the
10 advertisement or shown detailed contents of the advertisement displayed on the screen. The advertiser pays a predetermined advertising fee to the site manager in compensation for advertising his or her goods or company. The site manager pays a predetermined amount of money or points to the visitor in compensation for clicking on the banner advertisement.

15 However, the above-mentioned Internet banner advertisement method has a disadvantage in that a site manager can provide an advertisement to a user only when the user visits a site of the manager using a communication dedicated program, such as a general Web browser, or a communication dedicated program having a banner window formed on a certain position of the screen, provided by the manager, under the condition
20 that he or she remains linked to the Internet. That is, advertisers cannot gain such active access to users as when they provide other typical advertising media, and thus cannot help passively waiting for the users to access specific Internet sites associated with the advertisers.

Further, a banner advertisement is generally linked to a site of an advertiser or a
25 screen picture containing detailed contents thereof, and a user can move to the advertiser site or screen picture by accessing the Internet, visiting a site associated with the banner advertisement and clicking on the advertisement using a selection tool, such as a mouse. In this regard, the user cannot view the banner advertisement if he or she moves to any other site than the site associated with the advertisement. Namely, conventional banner
30 advertisements may become disposable, resulting in a reduction in advertising effects.

Besides, a conventional Internet advertisement is displayed on a predetermined

position of a homepage of a manager site while being limited in size, which leads to a limitation in the number of advertisements to be displayed. Moreover, the conventional Internet advertisement is shown to all users accessing the associated homepage, irrespective of the users' selections.

5 Accordingly, managers providing advertisements cannot provide a variety of advertisements in desired manners due to limitations of the online state, and advertisers cannot utilize a variety of advertisement methods. Further, users have no choice but to view uninteresting and uniform advertisements regardless of their selections. In particular, it is common practice that users use computers more frequently in the offline
10 state than in the online state. In this regard, it is preferred to provide advertisements in the offline state.

Disclosure of the Invention

Therefore, the present invention has been made in view of the above problems, and it is an object of the present invention to provide a computer advertisement method
15 using an advertisement dedicated program, wherein an advertiser-oriented advertisement or advertisement provider-oriented advertisement can be changed to a customer-oriented advertisement, and the advertisement dedicated program is installable in user computers to provide a specific advertisement to the computers, thereby enabling an advertiser of the specific advertisement to gain active access to users.

20 It is another object of the present invention to provide a computer advertisement method using an advertisement dedicated program, wherein users can select various forms of advertisements according to their tastes and use the selected advertisements in various ways.

In accordance with the present invention, the above and other objects can be
25 accomplished by the provision of a computer advertisement method using an advertisement dedicated program in an Internet system, the Internet system having a manager server for providing an advertisement associated site, at least one user computer connected to the manager server over an Internet network for performing online communication with the server, and at least one advertiser server connected to the

manager server over the Internet network for performing the online communication with the server, wherein the advertisement dedicated program is installable in the user computer to store all advertisements selectable by a user, send information about money or points acquired from an advertisement selected in an online state to the Internet network and information about money or points acquired from an advertisement selected in an offline state to the Internet network to the manager server, receive advertisements from the manager server in the online state if necessary, and provide new advertisements in the user computer regardless of the online or offline state, and wherein the user can select a desired advertisement in the offline state or an advertisement provided in the site in the online state and receive a predetermined amount of money or points in compensation for the advertisement selection, which are accumulatively added up and stored respectively in the advertisement dedicated program and the manager server.

Brief Description of the Drawings

The above and other objects, features and other advantages of the present invention will be more clearly understood from the following detailed description taken in conjunction with the accompanying drawings, in which:

Fig. 1 is a block diagram schematically showing the construction of an Internet system to which a computer advertisement method is applied according to the present invention;

Fig. 2 is a flowchart illustrating the computer advertisement method in accordance with the present invention;

Fig. 3 is a flowchart illustrating an advertisement selection/display step in accordance with the present invention; and

Fig. 4 is a view schematically showing an exemplary screen picture provided according to the present invention.

Best Mode for Carrying Out the Invention

With reference to Fig. 1, there is schematically shown in block form the

construction of an Internet system to which a computer advertisement method is applied according to the present invention.

As shown in Fig. 1, the Internet system comprises a manager server 10 including a registered member information database 11, money/point management server 12, accumulated money/point database 16, advertisement database 13, commodity database 14 and manager site 15, an Internet network 20, a user computer 30 connected to the manager site 15 via the Internet network 20 and having an advertisement dedicated program 31 installed therein, and an advertiser server 40 connected to the manager site 15 via the Internet network 20.

Fig. 2 is a flowchart illustrating the computer advertisement method in accordance with the present invention.

First, at an advertisement dedicated program start step S10, a user installs the advertisement dedicated program 31 in his or her user computer 30 and enters his or her identification (ID) and password to run the program 31 in the user computer 30 to manage all computer advertisements.

At an accumulated money/point confirmation step S20, if the advertisement dedicated program 31 is started to run in the user computer 30, then the user gains access to the manager site 15 over the Internet network 20 and downloads information about his or her own accumulated money or points stored in the accumulated money/point database 16 to the advertisement dedicated program 31 via the manager server 10 and money/point management server 12.

At an advertisement sending step S30, the manager server 10 sends advertisements from the advertisement database 13 to the advertisement dedicated program 31 in the user computer 30 over the Internet network 20 and registers the sent advertisements in the program 31.

At an advertisement selection/display step S40, the user selects a specific one of the advertisements registered in the advertisement dedicated program 31 in the user computer 30 and displays the selected advertisement on a screen of the computer 30.

At a money/point accumulation step S50, the user accumulates money or points acquired from the advertisement selected and displayed at the advertisement selection/display step S40 and money or points acquired from an advertisement selected

by himself or herself at the manager site 15 over the Internet network 20, in the advertisement dedicated program 31 installed in the user computer 30. The money/point management server 12 receives the accumulated result from the advertisement dedicated program 31 in the user computer 30 over the Internet network 20 and manager server 10 and adds the received result to the accumulated money or points stored in the accumulated money/point database 16 if it meets a predetermined condition.

At a money/point addition step S60, upon ending the advertisement dedicated program 31 installed in the user computer 30 or turning the computer 30 off, the user accumulates money or points acquired up to the present in the advertisement dedicated program 31 and then sends the accumulated result to the manager server 10 over the Internet network 20. The manager server 10 adds the accumulated result sent from the user to the accumulated money or points stored in the accumulated money/point database 16 via the money/point management server 12.

The computer advertisement method will hereinafter be described in more detail.

At the advertisement dedicated program start step S10, the user installs the advertisement dedicated program 31 in the user computer 30 and sets up environments of the program 31 such that the program 31 runs simultaneously with activation of the computer 30. As an alternative, the user may set up environments of the advertisement dedicated program 31 in such a manner that he or she can run the program 31 at a desired point of time during use of the user computer 30 in order to work on the computer 30 while viewing advertisements.

At the accumulated money/point confirmation step S20, if the advertisement dedicated program 31 is started to run in the user computer 30, then the user gains access to the manager site 15 over the Internet network 20 and downloads information about his or her own accumulated money or points stored in the accumulated money/point database 16 to the advertisement dedicated program 31 via the manager server 10 and money/point management server 12. Thereafter, the user adds money or points acquired afterwards to the downloaded money or points.

At the advertisement sending step S30, the manager server 10 extracts optimum advertisements from the advertisement database 13 according to the user's taste based on member information of the user stored in the registered member information database 11

and in response to an advertiser's request, sends the extracted advertisements to the advertisement dedicated program 31 in the user computer 30 over the Internet network 20 and then registers the sent advertisements in the program 31.

At the advertisement selection/display step S40, the user selects a specific one of the advertisements registered in the advertisement dedicated program 31 in the user computer 30 and displays the selected advertisement on the computer screen.

The advertisement selection/display step S40 includes, as shown in Fig. 3, an advertisement selection step S100 of selecting a desired one of various advertisements listed in an advertisement selection menu of the advertisement dedicated program 31, a using time/number counting step S110 of counting a period of time for which the user continuously uses the advertisement selected at the advertisement selection step S100 and the number of times that the user repeatedly uses the selected advertisement, and a money/point calculation step S120 of calculating money or points to be paid from an advertiser of the selected advertisement in compensation for the advertisement selection according to a contract with the advertiser and on the basis of the counted values.

At the money/point accumulation step S50, the user calculates money or points acquired from the advertisement selected through the advertisement dedicated program 31 and money or points acquired from an advertisement selected at the manager site 15 and accumulates the calculated result in the advertisement dedicated program 31 installed in the user computer 30. The money/point management server 12 receives the accumulated result from the advertisement dedicated program 31 in the user computer 30 over the Internet network 20, manager site 15 and manager server 10 and adds the received result to the accumulated money or points stored in the accumulated money/point database 16 if it meets a predetermined condition.

At the money/point addition step S60, upon ending the advertisement dedicated program 31 installed in the user computer 30 or turning the computer 30 off, the user accumulates money or points acquired up to the present in the advertisement dedicated program 31 and then sends the accumulated result to the manager server 10 over the Internet network 20. The manager server 10 adds the accumulated result sent from the user to the accumulated money or points stored in the accumulated money/point database 16 via the money/point management server 12.

As a result, when the user computer 30 is turned on or off, the accumulated money or points stored in the advertisement dedicated program 31 installed in the computer 30 are equal in amount to the accumulated money or points stored in the accumulated money/point database 16 connected to the money/point management server
5 12.

On the other hand, where the user uses the advertisement dedicated program 31 of the present invention in any other computer than his or her computer, information about his or her final, accumulated money or points stored in the accumulated money/point database 16 is downloaded to the advertisement dedicated program 31 via
10 the Internet network 20, manager site 15, manager server 10 and money/point management server 12 at the same time that the program 31 is started to run. Accordingly, the user can continuously add money or points acquired afterwards to the downloaded money or points while using the advertisement dedicated program in any other computer.

15 At the advertisement selection step S100, the user can select a desired one of the various advertisements listed in the advertisement selection menu of the advertisement dedicated program 31. Here, the listed various advertisements are all online and offline advertisements expressible in the computer. These advertisements may preferably include image advertisements expressed graphically on the screen 100 and audio
20 advertisements employing voice or music data.

Fig. 4 is a view schematically showing an exemplary screen picture provided according to the present invention, wherein image advertisements are expressed on the screen 100 in various ways.

In the present embodiment, the image advertisements may include disposable
25 advertisements displayed on the screen only one time according to the user's selection, insertion advertisements inserted in an operating system program and specific application program such that they are displayable on the screen, using time accumulation advertisements displayed continuously on the screen according to the user's selection for accumulating periods of time for which the user uses the advertisements and providing
30 money or points corresponding to the accumulated results to the user in compensation for using the advertisements, and using number count advertisements displayed repeatedly

on the screen according to the user's selection for counting the numbers of times that the user uses the advertisements.

The disposable advertisements may preferably include a banner advertisement 101 on the Internet for displaying a still picture, moving picture, animation, etc. with predetermined guide messages or graphic images on the screen upon being selected by the user and providing a predetermined amount of money or points to the user in compensation for the advertisement selection, and an electronic mail (E-mail) advertisement attached to an E-mail for displaying a still picture, moving picture, animation, etc. on the screen upon being received by the user and providing a predetermined amount of money or points to the user in compensation for the advertisement reception.

The insertion advertisements may preferably include operating system program insertion advertisements inserted in the operating system program for providing predetermined amounts of money or points to the user if they are used by him or her, and application program insertion advertisements inserted in the specific application program, such as a word processor, for providing predetermined amounts of money or points to the user if they are used by him or her. The operating system program insertion advertisements may preferably include a background picture advertisement 102, selection tool pointer advertisement 103, pointer shadow advertisement 104, screen saver advertisement, background picture pattern advertisement, icon advertisement 105 and print task active window advertisement having characters or symbols of advertisers inserted in a background picture, selection tool pointer (mouse or pen mouse), selection tool pointer shadow, screen saver, background picture pattern, icon and print task active window of the operating system program, respectively. The application program insertion advertisements may preferably include an edition background picture advertisement 106, cursor advertisement 107 and paragraph symbol advertisement 108 having logos or symbols of advertisers inserted in an edition background picture, cursor and paragraph symbol of the specific application program, respectively, and a pull-down menu advertisement 109, dialogue box advertisement, pop-up menu advertisement and help balloon advertisement having advertising contents and graphics related to a pull-down menu, dialogue box, pop-up menu and help balloon of the specific application

program, suitable to characteristics of the user and displayed on the screen together with those menus, respectively.

The using time accumulation advertisements may preferably include a plurality of advertisement dedicated window advertisements continuously displayed respectively
5 in a plurality of advertisement dedicated windows 110 on certain portions of the screen
100 according to the user's selection for continuously providing predetermined amounts of money or points to the user with the lapse of using time.

The using time accumulation advertisements may further include an insertion accumulation advertisement having a symbol or character of a specific advertiser inserted
10 in the background picture, selection tool pointer (mouse or pen mouse), selection tool pointer shadow, edition background picture, cursor and paragraph symbol for continuously providing a predetermined amount of money or points to the user with the lapse of using time.

The using number count advertisements may preferably include a plurality of
15 advertisement dedicated window advertisements displayed respectively in a plurality of advertisement dedicated windows 110 repeatedly at a certain period, a click pop-up advertisement inserted in the advertisement dedicated program 31 according to a contract with an associated advertiser for popping up advertising contents or graphics on the screen at the moment that a selection tool passes by a specific position of the screen,
20 displaying detailed advertising contents upon being clicked by the user and popping off the displayed contents if the selection tool leaves the specific position, and a key pop-up advertisement inserted in the advertisement dedicated program 31 according to a contract with an associated advertiser such that it is popped up on a portion of the screen, such as the advertisement dedicated window, whenever a specific key, such as a return (or enter)
25 key, is selected.

The above-stated image advertisements are stored in the advertisement dedicated program and periodically updated with new advertisement data from the manager. If the user clicks on a desired one of the image advertisements using a selection tool, then he or she can view detailed advertising contents of the clicked image advertisement or be
30 linked directly to a homepage thereof.

The audio advertisements may preferably include a sound effect advertisement

inserted in the operating system program such that it is generated when the operating system is started and while the operating system runs, an advertising sound advertisement expressed together with an associated image advertisement, and a background sound advertisement expressed continuously like background music. More preferably, the audio advertisements may employ all audio data containing voice data, music data and sound effect data.

Therefore, according to the present invention, the computer advertisement method using the advertisement dedicated program can provide advertisements to the user computer in such a manner that the user can personally manage all of the provided advertisements and acquire money or points from those advertisements. In addition, advertisers can provide optimum advertisements to the user in various forms, thereby maximizing advertising effects.

That is, a banner advertisement 101 can be provided on the Internet to display a still picture, moving picture, animation, etc. with predetermined guide messages or graphic images on the screen upon being selected by the user. The user can receive a predetermined amount of money or points in compensation for the advertisement selection. Also, an E-mail advertisement can be attached to an E-mail to display a still picture, moving picture, animation, etc. on the screen upon being received by the user, and the user can receive a predetermined amount of money or points in compensation for the advertisement reception.

A background picture advertisement 102, selection tool pointer advertisement 103, pointer shadow advertisement 104, screen saver advertisement, background picture pattern advertisement, icon advertisement 105 and print task active window advertisement can be inserted in an operating system program used often by the user. These advertisements can have characters or symbols of advertisers inserted, instead of existing graphic data, in a background picture, selection tool pointer (mouse or pen mouse), selection tool pointer shadow, screen saver, background picture pattern, icon and print task active window of the operating system program, respectively. Further, advertisements can be inserted in specific application programs, such as a word processor, graphic generation program, publication program, etc., according to separate contracts with advertisers. For example, for the word processor, there can be provided

an edition background picture advertisement 106, cursor advertisement 107 and paragraph symbol advertisement 108 having logos or symbols of advertisers inserted in an edition background picture, cursor and paragraph symbol, respectively.

Besides, for most application programs, there can be provided a pull-down menu advertisement 109, dialogue box advertisement, pop-up menu advertisement and help balloon advertisement having advertising contents and graphics related to a pull-down menu, dialogue box, pop-up menu and help balloon of each application program, suitable to characteristics of the user, such as the user's occupation, taste and age, and displayed on the screen together with those menus, respectively.

10 A plurality of advertisement dedicated window advertisements can be continuously displayed respectively in a plurality of advertisement dedicated windows 110 on certain portions of the screen 100 according to the user's selection to continuously provide predetermined amounts of money or points to the user with the lapse of using time. The user can change advertisements to be displayed in the advertisement dedicated windows, to appropriate ones based on his or her taste or desire and thus acquire money or points from the displayed advertisements without becoming 15 irritated by them. As a result, the user can use the advertisement dedicated window advertisements continuously for a lengthy period of time.

Preferably, the user can set up environments of the advertisement dedicated program 31 such that specific advertisements are displayed in the advertisement dedicated windows repeatedly at a fixed period. Accordingly, the user can more conveniently use the specific advertisements. Further, the user can set the number, position and size of the advertisement dedicated windows at his or her discretion and move them with a selection tool, such as a mouse, resulting in the convenience of use.

25 A click pop-up advertisement can be inserted in the advertisement dedicated program 31 according to a contract with an associated advertiser to pop up advertising contents or graphics on the screen at the moment that a selection tool, such as a mouse, passes by a specific position of the screen. Namely, the click pop-up advertisement can be based on coordinate values of the mouse. This pop-up advertisement can also display detailed advertising contents upon being clicked by the user and pop off the 30 displayed contents if the selection tool leaves the specific position. Thus, the user can

surf on the screen for advertisements with great interest, thereby maximizing advertising effects.

Preferably, the largest amount of money or points may be assigned to advertisements provided for the first time, so that the user can conveniently select such advertisements.

The above-described image advertisements all can be updated by the manager over the Internet at any time. If the user clicks on a desired one of the image advertisements using a selection tool, then he or she can view detailed advertising contents of the clicked image advertisement or be linked directly to a homepage thereof. Therefore, according to the present invention, advertisements can be provided to the user in either existing or improved methods.

The advertisement dedicated program is further adapted to insert voice data, music data and sound effect data in the operating system program to manage audio advertisements together with the above-stated image advertisements. A sound effect advertisement can be inserted in the operating system program such that it is generated when the operating system is started and while the operating system runs. Also, an advertising sound advertisement can be expressed together with an associated image advertisement, and a background sound advertisement can be expressed continuously like background music.

Industrial Applicability

As apparent from the above description, the present invention provides a computer advertisement method using an advertisement dedicated program. The advertisement dedicated program is installable in a user computer to integrately manage all expressible advertisements in the computer. The user can conveniently select a desired advertisement and receive a predetermined amount of money or points in compensation for viewing the selected advertisement. An advertisement provider can provide the advertisement selected by the user, which is an advertising target, in various forms according to the user's occupation, age, sex and taste. Therefore, the manager can efficiently connect the user to advertisers, thereby maximizing advertising effects.

Further, according to the present invention, advertisements can be provided to users at any time when the users use their computers, irrespective of an online or offline connection to the Internet. Also, the manager can send an updated advertisement dedicated program to the user computers whenever the users are connected to a site of the manager over the Internet. As a result, the manager is able to provide optimum advertisements to the users so as to increase advertising effects.

Although the preferred embodiments of the present invention have been disclosed for illustrative purposes, those skilled in the art will appreciate that various modifications, additions and substitutions are possible, without departing from the scope and spirit of the invention as disclosed in the accompanying claims.

Claims:

1. A computer advertisement method using an advertisement dedicated program, comprising the steps of:

5 a), by a user, installing the advertisement dedicated program in his or her user computer such that the program manages all computer advertisements;

b), by the user, gaining access to a manager site over an Internet network if said advertisement dedicated program is started to run in said user computer and downloading information about his or her own accumulated money or points stored in an accumulated money/point database to said advertisement dedicated program via a manager server and
10 money/point management server;

c), by said manager server, sending advertisements from an advertisement database to said advertisement dedicated program in said user computer over said Internet network and registering the sent advertisements in said program;

d), by said user, selecting a specific one of the advertisements registered in said advertisement dedicated program in said user computer and displaying the selected
15 advertisement on a screen of said computer;

e), by said user, accumulating money or points acquired from said advertisement selected and displayed at said step d) and money or points acquired from an advertisement selected by himself or herself at said manager site over said Internet
20 network, in said advertisement dedicated program installed in said user computer, and, by said money/point management server, receiving the accumulated result from said advertisement dedicated program in said user computer over said Internet network and manager server and adding the received result to the accumulated money or points stored in said accumulated money/point database if it meets a predetermined condition; and

f), by said user, accumulating money or points acquired up to the present in said advertisement dedicated program installed in said user computer upon ending said program or turning said computer off and then sending the accumulated result to said manager server over said Internet network, and, by said manager server, adding the accumulated result sent from said user to the accumulated money or points stored in said
25 accumulated money/point database via said money/point management server;

30

whereby, according to said advertisement dedicated program, said user selectively uses online and offline image advertisements expressed graphically on the screen of said user computer and online and offline audio advertisements with voice, music and sound effect data and acquires money or points in compensation for the advertisement use.

2. The computer advertisement method as set forth in Claim 1, wherein said image advertisements include:

disposable advertisements including a banner advertisement on the Internet for displaying a still picture, moving picture and animation with predetermined guide messages or graphic images on said screen upon being selected by said user, and an electronic mail advertisement attached to an electronic mail for displaying a still picture, moving picture and animation on said screen upon being received by said user;

insertion advertisements including operating system program insertion advertisements inserted in an operating system program, said operating system program insertion advertisements including a background picture advertisement, selection tool pointer advertisement, pointer shadow advertisement, screen saver advertisement, background picture pattern advertisement, icon advertisement and print task active window advertisement, and application program insertion advertisements inserted in a specific application program, said application program insertion advertisements including an edition background picture advertisement, cursor advertisement, paragraph symbol advertisement, pull-down menu advertisement, dialogue box advertisement, pop-up menu advertisement and help balloon advertisement;

using time accumulation advertisements including a plurality of advertisement dedicated window advertisements continuously displayed respectively in a plurality of advertisement dedicated windows on certain portions of said screen according to the user's selection, and an insertion accumulation advertisement having a symbol or character of a specific advertiser inserted in a background picture, selection tool pointer, selection tool pointer shadow, edition background picture, cursor and paragraph symbol for continuously providing a predetermined amount of money or points to said user with the lapse of using time; and

using number count advertisements including a plurality of advertisement dedicated window advertisements displayed respectively in a plurality of advertisement dedicated windows repeatedly at a certain period, a click pop-up advertisement inserted in said advertisement dedicated program according to a contract with an associated advertiser for popping up advertising contents or graphics on said screen at the moment that said user clicks on a specific position of said screen using a selection tool, and a key pop-up advertisement inserted in said advertisement dedicated program according to a contract with an associated advertiser such that it is popped up on a portion of said screen whenever a specific key is selected.

10 3. The computer advertisement method as set forth in Claim 1, wherein said audio advertisements include:

 a sound effect advertisement inserted in an operating system program such that it is generated when the operating system is started and while the operating system runs;

 an advertising sound advertisement expressed together with an associated image advertisement; and

15 a background sound advertisement expressed continuously like background music.

FIG. 1

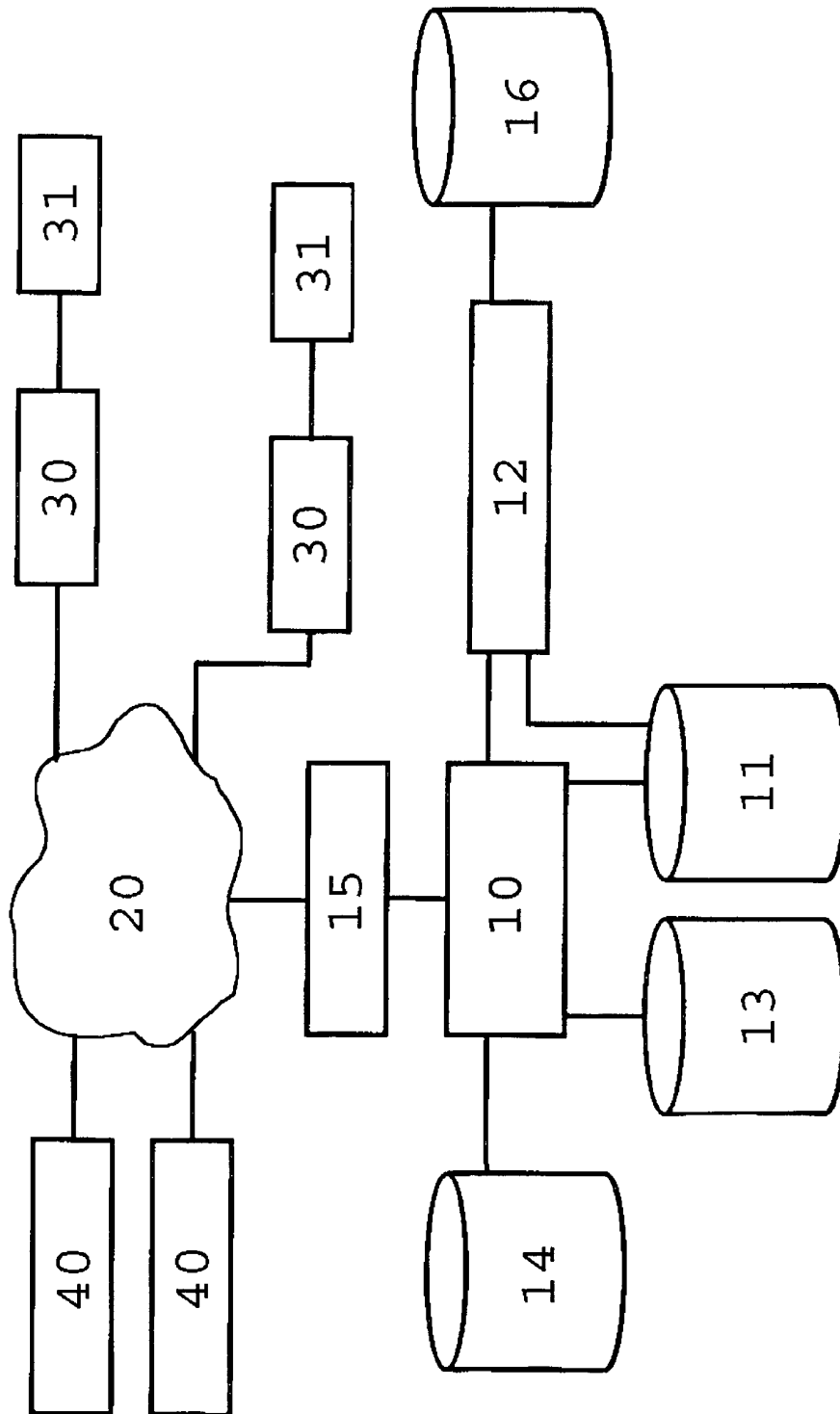

2 / 4

FIG. 2

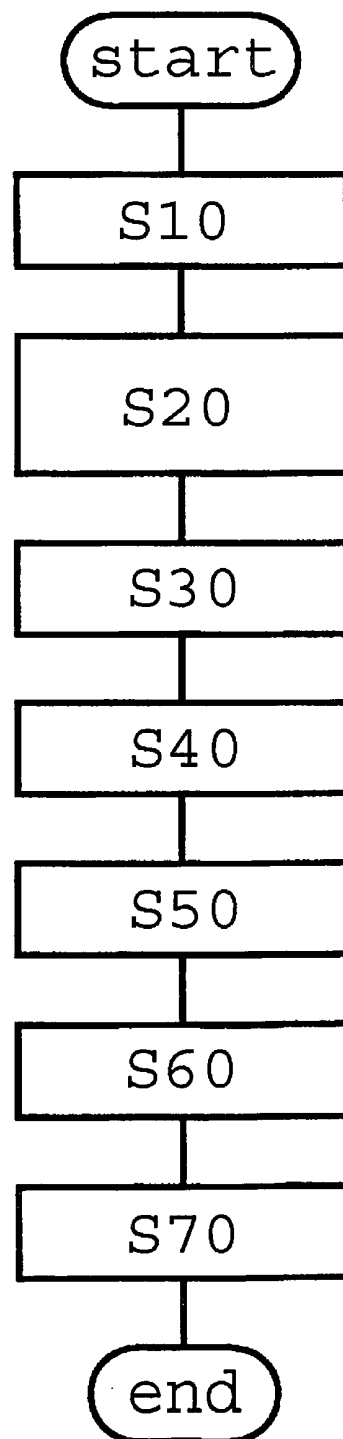

3 / 4

FIG. 3

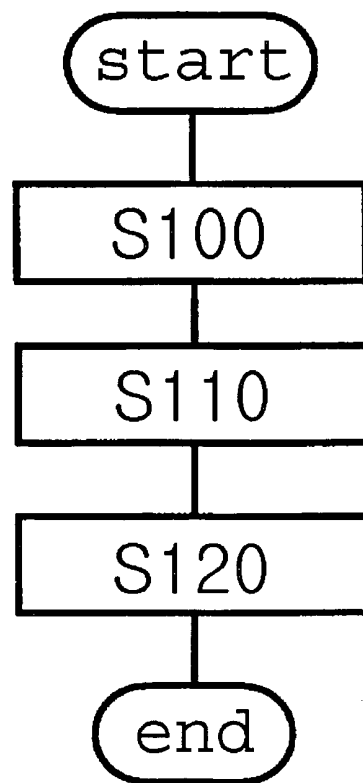
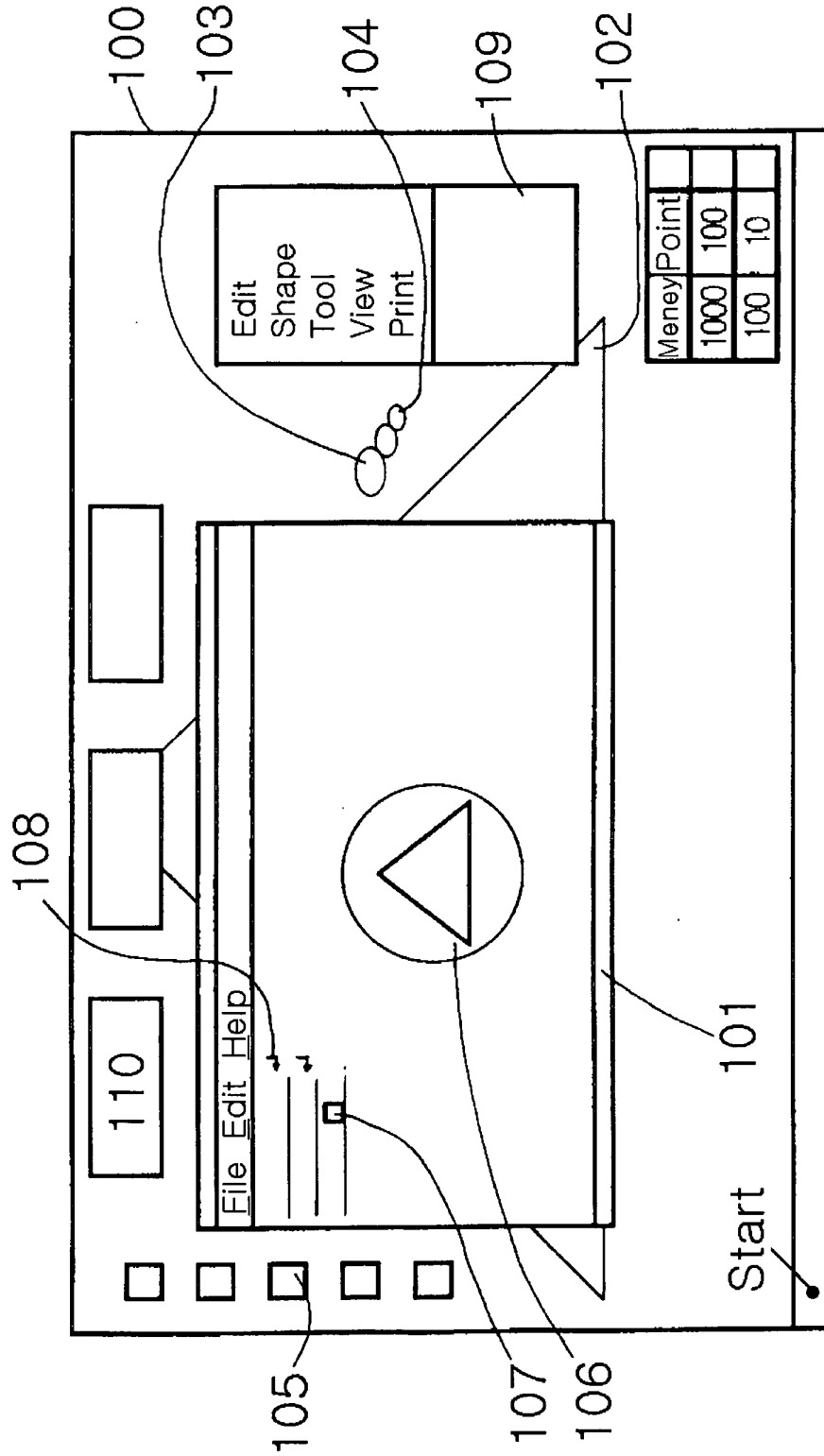

FIG. 4



INTERNATIONAL SEARCH REPORT

International application No.

PCT/KR01/00392

A. CLASSIFICATION OF SUBJECT MATTER**IPC7 G06F 17/60**

According to International Patent Classification (IPC) or to both national classification and IPC

B. FIELDS SEARCHED

Minimum documentation searched (classification system followed by classification symbols)

IPC7 G06F 17/60

Documentation searched other than minimum documentation to the extent that such documents are included in the fields searched
Korean Patents and applications for inventions since 1975

Electronic data base consulted during the international search (name of data base and, where practicable, search terms used)

C. DOCUMENTS CONSIDERED TO BE RELEVANT

Category*	Citation of document, with indication, where appropriate, of the relevant passages	Relevant to claim No.
P.X	KR 2000-24642 A (CHO DO-WON) 6 MAY 2000 See abstract	1
Y	US5740549 A (POINTCAST INC.) 14 APRIL 1998 See abstract	1-3
Y	US 5794210 A (CYBERGOLD INC.) 11 AUGUST 1998 See sponsorship part	1-3
Y	KR 99-78840 A (Lee joon-seo etc.) 5 NOVEMBER 1999 See abstract	1

 Further documents are listed in the continuation of Box C. See patent family annex.

* Special categories of cited documents:

"A" document defining the general state of the art which is not considered to be of particular relevance

"E" earlier application or patent but published on or after the international filing date

"L" document which may throw doubts on priority claim(s) or which is cited to establish the publication date of citation or other special reason (as specified)

"O" document referring to an oral disclosure, use, exhibition or other means

"P" document published prior to the international filing date but later than the priority date claimed

"T" later document published after the international filing date or priority date and not in conflict with the application but cited to understand the principle or theory underlying the invention

"X" document of particular relevance; the claimed invention cannot be considered novel or cannot be considered to involve an inventive step when the document is taken alone

"Y" document of particular relevance; the claimed invention cannot be considered to involve an inventive step when the document is combined with one or more other such documents, such combination being obvious to a person skilled in the art

"&" document member of the same patent family

Date of the actual completion of the international search

03 JULY 2001 (03.07.2001)

Date of mailing of the international search report

10 JULY 2001 (10.07.2001)

Name and mailing address of the ISA/KR

Korean Intellectual Property Office
Government Complex-Daejeon, Dunsan-dong, Seo-gu, Daejeon
Metropolitan City 302-701, Republic of Korea

Facsimile No. 82-42-472-7140

Authorized officer

JEONG, Jae Hoon

Telephone No. 82-42-481-5787

