

997,868.

L. C. STEELE.
CONVEYER TABLE.
APPLICATION FILED JAN. 31, 1910.

Patented July 11, 1911.

2 SHEETS—SHEET 1.

FIG. 1.

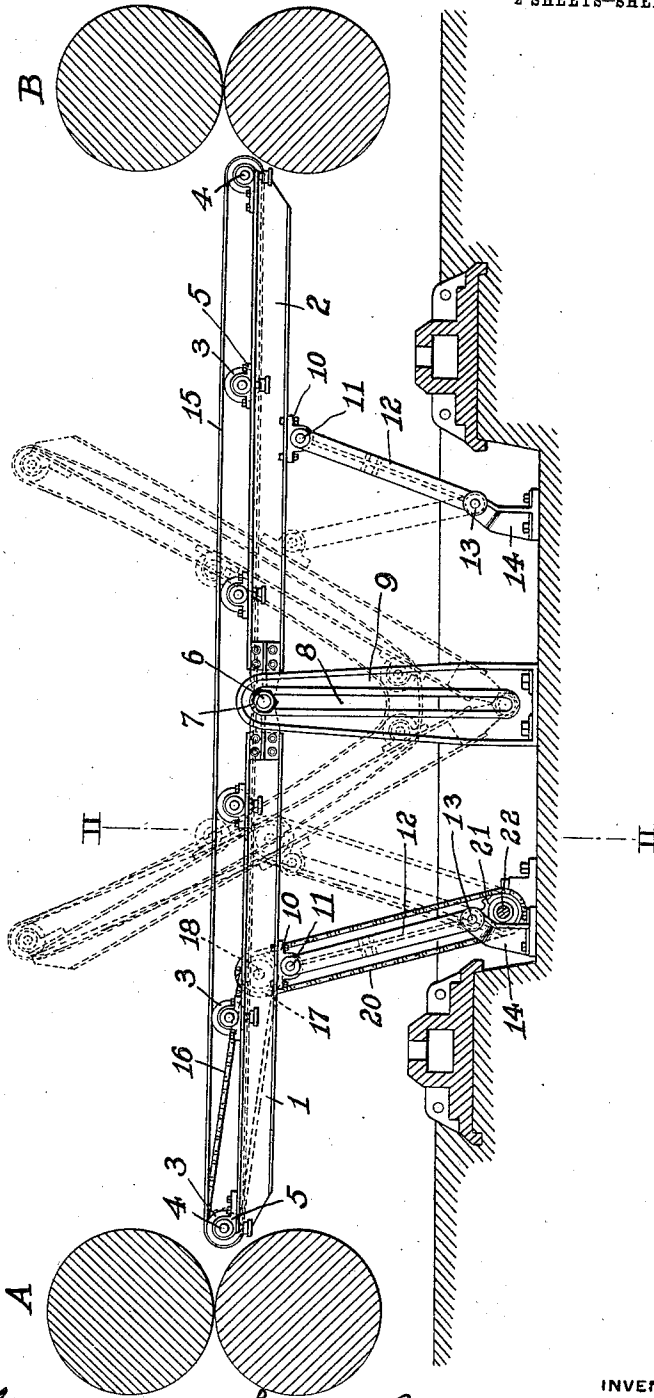

WITNESSES:
J. Herbert Bradley
Francis J. Tomason

INVENTOR
Lawrence Carr Steele
by Christy and Christy Atty's

997,868.

Patented July 11, 1911.

2 SHEETS—SHEET 2.

FIG. 2.

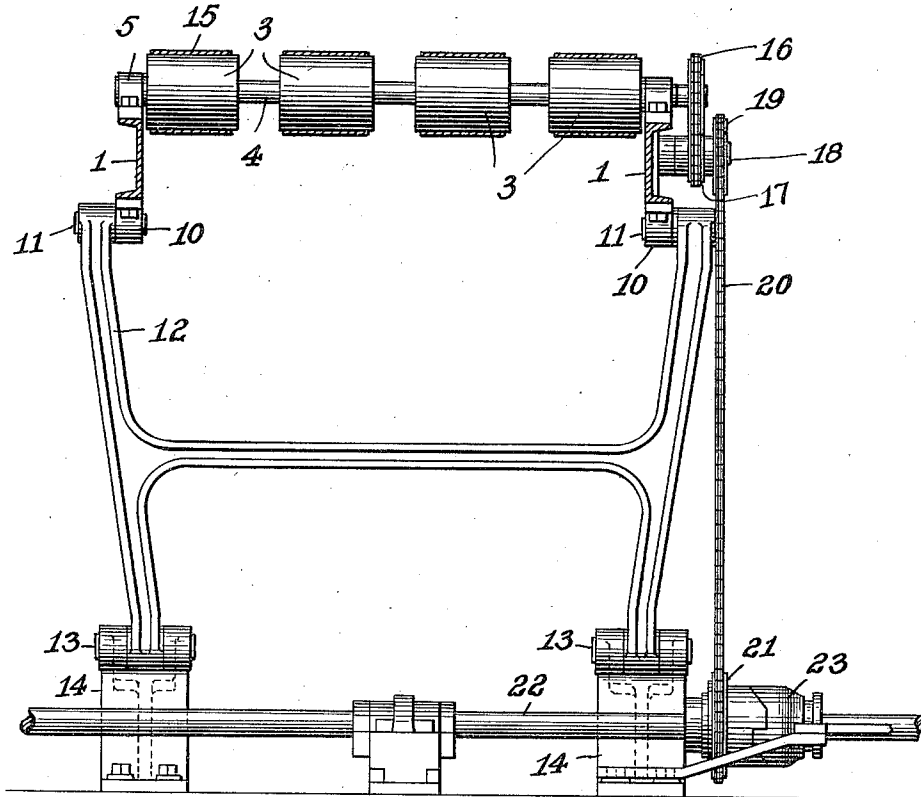

WITNESSES:

J. Herbert Bradley.
Francis J. Tomason

Lawrence Cass Steele INVENTOR
by Christy and Christy Atty's

UNITED STATES PATENT OFFICE.

LAWRENCE CARR STEELE, OF BEAVER, PENNSYLVANIA.

CONVEYER-TABLE.

997,868.

Specification of Letters Patent. Patented July 11, 1911.

Application filed January 31, 1910. Serial No. 541,165.

To all whom it may concern:

Be it known that I, LAWRENCE CARR STEELE, residing at Beaver, in the county of Beaver and State of Pennsylvania, a citizen of the United States, have invented or discovered certain new and useful Improvements in Conveyer-Tables, of which improvements the following is a specification.

My invention relates to improvements in transfer or conveying tables, and the object of my improvement is that such a table may be shifted with relation to the mechanism or apparatus which it is designed to serve, to afford free and ready access to the latter.

In the accompanying drawings which form part of this specification, I have shown my invention applied in the construction of a transfer table such as is used in a rolling mill, for conveying sheet metal from one roll pass to another in the operations of reducing or surfacing the metal.

In these drawings Figure 1 shows the table in side elevation, located between two sets of rolls which are shown in section; Fig. 2 is a view in vertical section of the table of Fig. 1, the plane of section being indicated at II—II Fig. 1.

This table, consisting of the frames 1 and 2, is placed as I have said between the two pairs of rolls A and B. Like other transfer tables it is provided with sets of rollers 3, carried on shafts 4, journaled in bearings 5 which are mounted in the table itself. The rollers 3 carry the endless belts 15. The frames 1 and 2, which together compose the body of the table proper, are hinged together on a shaft 6.

It is not new with me to build a conveying table in which one part is hinged on another to be swung aside. But, in such earlier tables known to me, the arrangement has been such that it has been a difficult and laborious matter to shift the hinged table parts; and, since in the ordinary operation of rolling mills it may be necessary to have access to the roll passes a number of times a day, the work of shifting the hinged tables becomes a serious matter. Furthermore, such hinged tables as have been used heretofore have been swung manually, and the swinging of them to and from operative position has involved disconnection of the driving mechanism. Again, in ordinary mill operation, it is at times desirable to employ only one of the two pairs of rolls between which a conveyer is installed, and

to replace the conveyer with an annealing stand. With conveyers such as are now employed, such replacing involves considerable work and consumes a great deal of time. My table is particularly designed to overcome these practical difficulties with earlier devices; and, while I shall describe in detail the construction illustrated, it will be understood that in its broader features my invention is not limited to exact details except as the scope of the claims demand.

The table is preferably made in two parts only, hinged in the middle. The shaft 6, upon which the hinged parts are pivoted, is loosely secured by bolts 7 in vertical slots 8 in standards 9 arranged on either side of the table. The arrangement is such that as the parts of the table swing on their pivot, that pivot joint itself may move in a direction transverse to the general plane in which the table normally extends, to facilitate the closure of its parts together.

Intermediate of its length, each of the hinged table parts is pivotally carried on an arm 12 which in turn is pivoted in a fixed support, such as the bearings 14 secured to the floor of the mill. These arms are so proportioned in length and position to the table and the runway 8 in which the hinge-joint travels, that, in whatever position the table may be it is sustained by and carried on these pivoted arms or supports 12.

The belts 15 which form the carriers and which travel on rollers 3 are positively driven, and it is part of my invention to coordinate the driving means with the means for swinging the table. To this end, a sprocket wheel carried on one of the shafts 4 is driven by a sprocket chain 16 from a sprocket wheel 17, which in turn is driven in like manner by a third wheel 19, from a fourth wheel 21, carried on a power shaft 22, which power shaft 22 is supported on a fixed support which would ordinarily be the factory floor. The arrangement of the sprocket wheels 19 and 21 is such that as the table swings, the sprocket chain 20 which passes over them will not be drawn appreciably tighter to prevent the free swinging of the table, but rather will be somewhat loosened, and to this end these sprocket wheels 19 and 21 are conveniently centered at points adjacent to the pivoted points of the supporting arms 12. The particular arrangement which the drawings show is such that when the table

is in its normal extended position, the supporting arm 12 lies between and in line with the centers of these two sprocket wheels 19 and 21, and as the table is swung to its alternative position there is substantially no change in the distance between these two sprocket wheels. A clutch 23 on power shaft 22 permits the stopping of the belt when desired, as when the table is swung from operative position.

In Fig. 1 the inoperative position of the table is shown in dotted lines, that is, the position to which the table is swung to permit access to the roll passes.

It will be understood that, by virtue of the balanced support of the table parts intermediate their length, the shifting of the table for such purposes as are described above is accomplished readily and with expenditure of relatively little power or effort.

While I have described my invention in its application to a rolling-mill transfer table, it will be understood that it is generally applicable to tables where such moving and collapsing of the table itself may be beneficially employed.

I claim herein as my invention:

1. In a transverse table structure two table parts united in a hinge joint, the said table parts being movable upon their common pivot from extended to closed position, and the said hinge joint being movable in a direction transverse to the plane in which the table normally extends, substantially as described.

2. In a transfer-table structure, the combination with a table section provided with a driving shaft for a carrier belt and pivoted intermediate its length to a supporting arm pivotally carried on a fixed support, of means for driving said carrier-belt shaft, said driving means including two sprocket wheels with an operating chain, one of said wheels being carried by said table section and the other upon said fixed support, the centers upon which said sprocket wheels are mounted being located adjacent to the pivot points of the said supporting arm, substantially as described.

3. In a transfer-table structure, the combination with a table section provided with a driving shaft for a carrier belt and pivoted intermediate its length to a supporting arm pivotally carried on a fixed support, of means for driving said carrier-belt shaft, said driving means including two sprocket wheels with an operating chain, one of said wheels being carried by said table section and the other upon said fixed support, said table-supporting arm lying substantially between and in line with the centers of said sprocket wheels when the table is in normal extended position, substantially as described.

In testimony whereof, I have hereunto set my hand.

LAWRENCE CARR STEELE.

Witnesses:

BAYARD H. CHRISTY,
SUE B. FRITZ.