

(19)



(11)

EP 4 495 520 A1

(12)

EUROPEAN PATENT APPLICATION

(43) Date of publication:
22.01.2025 Bulletin 2025/04

(51) International Patent Classification (IPC):
F25J 1/00^(2006.01)

(21) Application number: **23306259.5**

(52) Cooperative Patent Classification (CPC):
**F25J 1/0052; F25J 1/0022; F25J 1/0072;
F25J 1/0082; F25J 1/0205; F25J 1/0215;
F25J 1/0268; F25J 1/0283; F25J 1/0284;
F25J 2260/30; F25J 2270/12; F25J 2270/60;
F25J 2270/66**

(22) Date of filing: **21.07.2023**

(84) Designated Contracting States:
**AL AT BE BG CH CY CZ DE DK EE ES FI FR GB
GR HR HU IE IS IT LI LT LU LV MC ME MK MT NL
NO PL PT RO RS SE SI SK SM TR**
Designated Extension States:
BA
Designated Validation States:
KH MA MD TN

(72) Inventors:
• **RACINE, Alice**
92400 COURBEVOIE (FR)
• **HAVIL, Patrick**
92400 COURBEVOIE (FR)
• **KHAIRALLAH, Michael**
91120 PALAISEAU (FR)
• **ZOUGHAI, Assaad**
91120 PALAISEAU (FR)

(71) Applicant: **TOTALENERGIES ONETECH**
92400 Courbevoie (FR)

(74) Representative: **Lavoix**
2, place d'Estienne d'Orves
75441 Paris Cedex 09 (FR)

(54) **PRE-COOLING UNIT FOR A LIQUEFIED NATURAL GAS PRODUCTION FACILITY WITH IMPROVED EFFICIENCY**

(57) The pre-cooling unit is for use in a liquefied natural gas production facility configured for producing liquefied natural gas from a feed gas containing methane. The pre-cooling unit comprises:
- a pre-cooling refrigeration circuit (24) for producing cold with circulation of a pre-cooling refrigeration fluid, the pre-cooling refrigeration circuit (24) being thermally coupled to a feed gas line via one or more pre-cooling heat exchanger for transferring cold from the refrigeration fluid

to the feed gas; and
- a sub-cooling unit (30) comprising a sub-cooling refrigeration circuit (32) for producing cold with circulation of sub-cooling refrigeration fluid, the sub-cooling refrigeration circuit (32) being thermally couple to the pre-cooling refrigeration circuit (24) for transferring cold from the sub-cooling refrigeration circuit (32) to the pre-cooling refrigeration circuit (24).

FIG.2

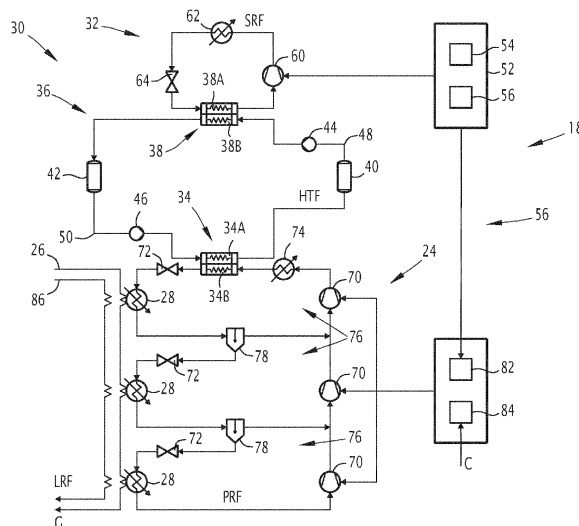

EP 4 495 520 A1

Description

[0001] The present invention relates to the technical field of production of liquefied natural gas (or LNG) and in particular to a pre-cooling unit for a LNG production facility.

[0002] A LNG production facility (also called "LNG train") is configured for producing liquefied natural gas (LNG) from a feed gas containing methane. The LNG production facility is configured for cooling the feed gas stepwise. The LNG production facility comprises a pre-cooling unit for pre-cooling the feed gas, e.g. down to a temperature around - 35°C, and a liquefaction unit for cooling the feed gas to liquid state, e.g. down to a temperature around - 160°C.

[0003] The pre-cooling unit generally comprises a pre-cooling refrigeration circuit thermally coupled to a feed gas line for transferring cold produced in the pre-cooling refrigeration circuit to the feed gas, the pre-cooling refrigeration circuit comprising one or several compressors mechanically coupled to and driven by a gas turbine, as gas is easily accessible in the LNG production facility.

[0004] The liquefaction unit comprises a liquefaction refrigeration circuit for producing cold with using a liquefaction refrigeration fluid (also referred to as "liquefaction refrigeration mix" as the liquefaction refrigeration fluid generally comprises a mix of refrigeration gases), the liquefaction refrigeration circuit being thermally coupled to the feed gas line for transferring cold produced in the liquefaction refrigeration circuit to the feed gas.

[0005] The liquefaction refrigeration circuit is optionally thermally coupled to the pre-cooling refrigeration circuit for transferring cold from the pre-cooling refrigeration fluid to the refrigeration mix.

[0006] One of the aims of the invention is to propose a solution for improving the efficiency of an LNG production facility.

[0007] To this end, the invention propose a pre-cooling unit for a liquefied natural gas production facility configured for producing liquefied natural gas from a feed gas containing methane, the pre-cooling unit comprising :

- a pre-cooling refrigeration circuit for producing cold with circulation of a pre-cooling refrigeration fluid, the pre-cooling refrigeration circuit being thermally coupled to a feed gas line via one or more pre-cooling heat exchanger for transferring cold from the refrigeration fluid to the feed gas; and
- a sub-cooling unit comprising a sub-cooling refrigeration circuit for producing cold with circulation of sub-cooling refrigeration fluid, the sub-cooling refrigeration circuit being thermally couple to the pre-cooling refrigeration circuit for transferring cold from the sub-cooling refrigeration circuit to the pre-cooling refrigeration circuit.

[0008] The sub-cooling unit comprising the sub-cooling refrigeration circuit allows producing cold in the sub-

cooling refrigeration circuit separately from the pre-cooling refrigeration circuit and then transferring said cold from the sub-cooling refrigeration circuit to the pre-cooling refrigeration circuit.

[0009] The sub-cooling refrigeration circuit can be operated efficiently independently from the pre-cooling refrigeration circuit, e.g. as a function of the availability of an energy source used for feeding the sub-cooling refrigeration circuit, the cold being then transferred from the sub-cooling refrigeration circuit to the pre-cooling refrigeration circuit when needed and/or appropriate for sake of efficiency.

[0010] In some embodiments, the pre-cooling unit comprises one or several of the following optional features, taken individually or according to any technically feasible combination:

- the sub-cooling refrigeration circuit is thermally coupled to the pre-cooling refrigeration circuit via a releasing heat exchanger;
- the sub-cooling refrigeration circuit is thermally coupled to the pre-cooling refrigeration circuit a heat transfer circuit configured for circulation of a heat transfer fluid, the heat transfer circuit being thermally coupled with the sub-cooling refrigeration circuit via a collecting heat exchanger for collecting cold from the sub-cooling refrigeration circuit and thermally coupled with the pre-cooling refrigeration circuit via a releasing heat exchanger for releasing cold to the pre-cooling refrigeration fluid;
- the heat transfer circuit comprises at least one tank for storing the heat transfer fluid and at least one pump for circulating the heat transfer fluid from the tank to the collecting heat exchanger and/or the releasing heat exchanger;
- the heat transfer circuit comprises a first tank for storing the heat transfer fluid, a second tank for storing heat transfer fluid and a least one pump for selectively circulating the heat transfer fluid from the first tank to the second tank via the collecting heat exchanger or circulating the heat transfer fluid from the second tank to the first tank via the releasing heat exchanger;
- the heat transfer circuit comprises a first pump for circulating the heat transfer fluid from the first tank to the second tank via the collecting heat exchanger and a second pump for circulating the heat transfer fluid from the second tank to the first tank via the releasing heat exchanger, the first pump and the second pump being distinct;
- the pre-cooling unit is configured for activating the first pump intermittently and for activating the second pump continuously during operation of the pre-cooling unit;
- the sub-cooling unit is connected to an electricity producing unit configured for producing electrical energy, in particular from one or several renewable energy sources, and feeding the sub-cooling unit

with said electrical energy for operation of the sub-cooling unit;

- the sub-cooling refrigeration circuit comprises a sub-cooling compressor, a sub-cooling condenser, and a sub-cooling reducer, the collecting heat exchanger being arranged in series between the sub-cooling reducer and the sub-cooling compressor;
- the heat transfer fluid is water or a mix of water and glycol and/or the sub-cooling refrigeration fluid contains propane and/or butane, and is for example propane, butane or a propane/butane mix, in particular a propane/butane mix containing at least 50wt% of propane, preferably 60wt% of propane, in particular between 65 wt% and 75 wt% of propane;
- the pre-cooling refrigeration circuit comprises one or several compressors, the releasing heat exchanger being arranged in the pre-cooling refrigeration circuit between one of said one or several compressors and an expansion member;
- the pre-cooling refrigeration circuit comprises several refrigeration loops, each refrigeration loop comprising a compressor, the compressors of the refrigeration loops being for example distinct stages of a same common compressor;
- the pre-cooling unit comprises a gas turbine mechanically coupled to the compressor(s) of the pre-cooling refrigeration circuit for driving the compressor(s) of the pre-cooling refrigeration circuit; and
- refrigeration loops are fluidly connected in series in a cascade, each following refrigeration loop receiving pre-cooling refrigeration fluid in liquid state from the preceding refrigeration loop, the outlet of the pre-cooling compressor of each following refrigeration loop being fluidly feeding the inlet of the pre-cooling compressor of the preceding refrigeration loop.

[0011] The invention also relates to a liquefied natural gas production facility configured for producing liquefied natural gas from a feed gas containing methane, the liquefied natural gas production facility comprising the precooling unit as defined above.

[0012] The invention also relates to a method of pre-cooling unit feed gas in a liquefied natural gas production facility configured for producing liquefied natural gas from the feed gas, the feed gas containing methane, the method comprising :

- producing cold in a pre-cooling refrigeration circuit with a pre-cooling refrigeration fluid and transferring the cold from the pre-cooling refrigeration fluid to the feed gas via one or more pre-cooling condensers;
- producing cold in a sub-cooling refrigeration circuit with a sub-cooling refrigeration fluid and transferring cold from the sub-cooling refrigeration circuit to the pre-cooling refrigeration circuit.

[0013] In some examples, the transfer of cold from the sub-cooling refrigeration circuit to the pre-cooling refrigeration

circuit is operated via a heat transfer circuit configured for circulation of a heat transfer fluid, the heat transfer circuit being thermally coupled with the sub-cooling refrigeration circuit via a collecting heat exchanger and thermally couple with the pre-cooling refrigeration circuit via a releasing heat exchanger.

[0014] The invention and its advantages will be better understood upon reading the following description, which is given solely by way of non-limiting example and made with reference to the appended drawings, in which:

- Figure 1 is a diagrammatical view of an LNG production facility
- Figure 2 is a diagrammatical view of a pre-cooling unit of the LNG production facility of Figure 1.

[0015] As illustrated on Figure 1, a LNG production facility 10 is configured for receiving a feed gas G containing methane from a gas source 12 and processing the feed gas G to provide liquefied natural gas LNG, for example to a storage reservoir 14.

[0016] The gas source 12 provides the feed gas G to the LNG production facility 10 in a gaseous state. The liquefied natural gas LNG is stored in the storage reservoir in a liquid state. The storage reservoir 14 may be on the ground or onboard a land vehicle or onboard a marine vehicle, in particular a LNG transport vessel.

[0017] The LNG production facility 10 comprises a purification unit 16, a pre-cooling unit 18 and a liquefaction unit 20 fluidly connected in series.

[0018] The purification unit 16 is configured for removing impurities from the feed gas G and/or for removing undesired chemical compounds from the feed gas G, such as carbon dioxide (CO₂) and/or hydrogen Sulfide (H₂S) and/or mercury (Hg), and/or for removing water (H₂O) from the feed gas G, i.e. for dehydrating the feed gas G.

[0019] The purification unit 16 is optional. The purification unit 16 is for example provided and configured for the appropriate purification as a function of the natural gas provided by the gas source 12.

[0020] The pre-cooling unit 18 is configured for cooling the feed gas G from an initial temperature which is for example comprises between 0°C and 50°C, down to a pre-cooling temperature which is for example comprised between -20°C and -40°C, preferably between -25°C and -35°C, in particular around -30°C.

[0021] The liquefaction unit 20 is configured for cooling the feed gas G from the pre-cooling temperature to a final temperature strictly inferior to the liquefaction temperature of the feed gas G, such that the feed gas G is in liquid state.

[0022] As illustrated on Figure 2, the pre-cooling unit 18 comprises a pre-cooling refrigeration circuit 24 configured for producing cold with a pre-cooling refrigeration fluid PRF circulating in the pre-cooling refrigeration circuit 24, the pre-cooling refrigeration circuit 24 being thermally coupled to a feed gas line 26 for circulation of the feed gas

G via one or several pre-cooling heat exchangers 28, each pre-cooling heat exchanger 28 being configured for transferring cold from the pre-cooling refrigeration fluid PRF to the feed gas G circulating in the feed gas line 26.

[0023] In the present context, a "heat exchanger" for transferring thermal energy (cold or heat) from a first fluid to a second fluid comprises a first chamber for the circulation of the first fluid and a second chamber for the circulation of the second fluid, the first chamber and the second chamber being separated by a separation wall delimiting the first chamber on one side and the second chamber on the other side, the first fluid and the second fluid exchanging thermal energy via by thermal conduction through the separation wall.

[0024] The pre-cooling unit 18 comprises a sub-cooling unit 30 comprising a sub-cooling refrigeration circuit 32 for producing cold with a sub-cooling refrigeration fluid SRF circulating in the sub-cooling refrigeration circuit 32, the sub-cooling refrigeration circuit 32 being thermally coupled to the pre-cooling refrigeration circuit 24 for transferring cold from the sub-cooling refrigeration circuit 32 to the pre-cooling refrigeration circuit 24, more particularly from the sub-cooling refrigeration fluid SRF to the pre-cooling refrigeration fluid PRF.

[0025] The sub-cooling refrigeration circuit 32 is for example thermally coupled to the pre-cooling refrigeration circuit 24 via a releasing heat exchanger 34 arranged for transferring cold from the sub-cooling refrigeration circuit 32 to the pre-cooling refrigeration circuit 24, more particularly from the sub-cooling refrigeration fluid SRF to the pre-cooling refrigeration fluid PRF.

[0026] Preferably, the sub-cooling refrigeration circuit 32 is thermally coupled to the pre-cooling refrigeration circuit 24 via a heat transfer circuit 36 configured for circulation of a heat transfer fluid HTF, the heat transfer circuit 36 being thermally coupled with the sub-cooling refrigeration circuit 32 via a collecting heat exchanger 38 arranged for transferring cold from the sub-cooling refrigeration circuit 32 to the heat transfer circuit 36, in particular from the sub-cooling refrigeration fluid SRF to the heat transfer fluid HTF, and thermally coupled with the pre-cooling refrigeration circuit 24 via the releasing heat exchanger 34 arranged for transferring cold from the heat transfer circuit to the pre-cooling refrigeration circuit 24, in particular from the heat transfer fluid HTF to the pre-cooling refrigeration fluid PRF.

[0027] The collecting heat exchanger 38 is fluidly connected in the sub-cooling refrigeration circuit 32 for the circulation of the sub-cooling refrigeration fluid SRF via a first chamber 38A of the collecting heat exchanger 38 and fluidly connected in the heat transfer circuit 36 for the circulation of heat transfer fluid HTF via a second chamber 38B of the collecting heat exchanger 38 with a thermal exchange between the sub-cooling refrigeration fluid SRF and heat transfer fluid HTF by thermal conduction via a separation wall of the collecting heat exchanger 38 separating the first chamber 38A and the second chamber 38B one from the other.

[0028] The releasing heat exchanger 34 is fluidly connected in the heat transfer circuit 36 for the circulation of the heat transfer fluid HTF via a first chamber 34A of the releasing heat exchanger 34 and fluidly connected to the pre-cooling refrigeration circuit 24 for the circulation of pre-cooling refrigeration fluid PRF via a second chamber 34B of the releasing heat exchanger 34 with a thermal exchange between the heat transfer fluid HTF and the pre-cooling refrigeration fluid PRF by thermal conduction through a separation wall of the releasing heat exchanger 34 separating the first chamber 34A and the second chamber 34B one from the other.

[0029] When the LNG production facility 10 is in operation, the feed gas G is fed continuously to the LNG production facility 10 and the operation of the pre-cooling refrigeration circuit 24 is continuous. There is no interruption in the operation of the pre-cooling refrigeration circuit 24. However, the sub-cooling refrigeration circuit 30 may produce cold intermittently and/or produce an amount of cold that varies with time, e.g. if a source of energy used for operating the sub-cooling refrigeration circuit 32 is intermittent, such as a renewable source of energy.

[0030] The heat transfer circuit 36 is preferably configured for allowing collecting cold from the sub-cooling refrigeration fluid SRF of the sub-cooling refrigeration circuit 32 intermittently whilst releasing cold to the pre-cooling refrigeration fluid PRF of the pre-cooling refrigeration circuit 24 continuously.

[0031] This allows accounting for the intermittent operation of the sub-cooling refrigeration circuit 32 and the continuous operation of the pre-cooling refrigeration circuit 24.

[0032] Advantageously, the heat transfer circuit 36 comprises one or several tanks for storing the heat transfer fluid HTF and at least one pump arranged for circulating the heat transfer fluid HTF between each tank, the collecting heat exchanger 38 and the releasing heat exchanger 34.

[0033] The provision of one or several tanks allows using each tank as a buffer and circulating the heat transfer fluid HTF in the heat transfer circuit 36 as a function of the operation of the sub-cooling refrigeration circuit 32 and/or of the operation the pre-cooling refrigeration circuit 24.

[0034] Preferably, the heat transfer circuit 36 comprises a first tank 40 for storing the heat transfer fluid HTF, a second tank 42 for storing heat transfer fluid HTF and a least one pump fluidly connected to the first tank 40, the second tank 42, the collecting heat exchanger 38 and the releasing heat exchanger 34 for allowing circulating the heat transfer fluid HTF from the first tank 40 to the second tank 42 via the collecting heat exchanger 38 and circulating the heat transfer fluid HTF from the second tank 42 to the first tank 40 via the releasing heat exchanger 34.

[0035] With such an arrangement, the first tank 40 receives the heat transfer fluid HTF after the heat ex-

change with the sub-cooling refrigeration fluid SRF and the second tank 42 receives the heat transfer fluid HTF after the heat exchange with the pre-cooling refrigeration fluid PRF.

[0036] The first tank 40 allows storing the heat transfer fluid HTF at a first temperature range and the second tank 40 allows storing the heat transfer fluid HTF at a second temperature, the first temperature range being higher than the second temperature range.

[0037] The heat transfer circuit 36 is preferably configured for allowing simultaneously the circulation of the heat transfer fluid HTF from the first tank 40 to the second tank 42 via the collecting heat exchanger 38 and the circulation of the heat transfer fluid from the second tank 42 to the first tank 40 via the releasing heat exchanger 34.

[0038] This allows independent and efficient operations of the sub-cooling refrigeration circuit 32 and the pre-cooling refrigeration circuit 24 with transferring the cold produced by sub-cooling refrigeration circuit 32 to the pre-cooling refrigeration circuit 24 with the appropriate timing and rate.

[0039] The heat transfer circuit 36 comprises for example a first pump 44 for circulating the heat transfer fluid HTF from the first tank 40 to the second tank 42 via the collecting heat exchanger 38 and a second pump 46 for circulating the heat transfer fluid HTF from the second tank 42 to the first tank 40 via the releasing heat exchanger 34. The first pump 44 and the second pump 46 are distinct.

[0040] The heat transfer circuit 36 preferably comprises a first fluid line 48 fluidly connecting the first tank 40 to the second tank 42 via the first pump 44 and the collecting heat exchanger 38 and a second fluid line 50 fluidly connecting the second tank 42 to the first tank 40 via the second pump 46 and the release heat exchanger 34. The first fluid line 48 and the second fluid line 50 are separated.

[0041] The pre-cooling unit 18 has one or several operation modes in which the heat transfer circuit 36 is operated as a function of the operation of the pre-cooling refrigeration circuit 24 and the operation of the sub-cooling refrigeration circuit 32.

[0042] The pre-cooling unit 18 has for example at least one operation mode in which the first pump 44 is activated intermittently, the first pump 44 being activated preferably when the sub-cooling refrigeration circuit 32 is active and generates cold, and the second pump 46 is activated continuously during operation of the pre-cooling unit 18.

[0043] The pre-cooling unit 18 comprises for example a cold storage operating mode in which the sub-cooling refrigeration circuit 32 produces cold in excess as compared to the need of the pre-cooling unit 24, and the heat transfer circuit 36 is operated for circulating the heat transfer fluid HTF from the first tank 40 to the second tank 42 via the collecting heat exchanger 38 and storing the heat transfer fluid HTF in second tank 42.

[0044] The pre-cooling unit 18 comprises for example

a cold release operating mode in which the sub-cooling refrigeration circuit 30 is not operating or produces not enough cold as compared to the need of the pre-cooling unit 24, and the heat transfer circuit 36 is operated for circulating the heat transfer fluid HTF from the second tank 42 to the first tank 40 via the releasing heat exchanger 34 for transferring cold previously produced by the sub-cooling refrigeration circuit 32 to the pre-cooling refrigeration circuit 24.

[0045] The sub-cooling unit 30 is for example operated using electrical energy provided by an electrical energy providing unit 52 configured for providing energy necessary to the operation of the sub-cooling unit 30, in particular the electrical energy necessary to the operation of the sub-cooling refrigeration circuit 32.

[0046] The electricity production unit 52 comprises for example one or several renewable electricity production devices 54 each configured for generating electrical energy from one or several renewable energy sources, the renewable energy sources being for example solar energy, wind energy, geothermal energy, hydraulic energy (or hydropower) or wave energy.

[0047] Each renewable electricity production device 54 is for example chosen from the group consisting of a solar concentration device, a photovoltaic device, a wind turbine (offshore or onshore), a hydroelectric turbine, a hydroelectric dam, a wave energy converter and a geothermal device.

[0048] Alternatively or optionally, the electricity production unit 52 comprises for example at least one additional electricity production device 56, each additional electricity production device 56 being for example an electrical power grid and/or a gas turbine.

[0049] The sub-cooling refrigeration circuit 32 is configured for operating a refrigeration cycle with the sub-cooling refrigeration fluid SRF.

[0050] The sub-cooling refrigeration circuit 32 comprises for example a sub-cooling compressor 60, a sub-cooling condenser 62 and a sub-cooling expansion member 64 and the collecting heat exchanger 36 connected fluidly in series in a closed loop, the collecting heat exchanger 38 being connected located between the sub-cooling expansion member 64 and the sub-cooling compressor 60. The sub-cooling expansion member 64 is for example an expansion valve.

[0051] The sub-cooling compressor 60 is preferably an electrical compressor using electrical energy, provided e.g. by the electrical energy providing unit 52, for compressing the sub-cooling refrigeration fluid SRF.

[0052] The sub-cooling refrigeration fluid SRF is for example a gas or a mix of gases. The sub-cooling refrigeration fluid SRF contains for example propane and/or butane. The sub-cooling refrigeration fluid SRF is for example propane, butane or a propane/butane mix, in particular a propane/butane mix containing at least 50wt% of propane, preferably 60wt% of propane, in particular between 65 wt% and 75 wt% of propane.

[0053] Such a sub-cooling refrigeration fluid SRF al-

lows producing cold efficiently with a cold amount and/or a temperature appropriate for an efficient heat exchange with the pre-cooling refrigeration fluid PRF. Propane and Butane have the advantage to be easily accessible in a LNG production facility.

[0054] The heat transfer fluid HTF is for example water or a mix of water and glycol. Such a heat transfer fluid HTF has an appropriate cold storage capacity and can stay in a liquid state at low temperatures.

[0055] The pre-cooling refrigeration circuit 24 is configured for operating a refrigeration cycle with the pre-cooling refrigeration fluid PRF including compression and expansion of the pre-cooling refrigeration fluid PRF, with collecting cold from the sub-cooling refrigeration circuit 32, preferably by passing the pre-cooling refrigeration fluid PRF via a releasing heat exchanger 34 thermally coupling the sub-cooling refrigeration circuit 32 to the pre-cooling refrigeration circuit 24, and releasing cold from the pre-cooling refrigeration fluid PRF to the feed gas G, in particular in each pre-cooling heat exchanger 28.

[0056] The pre-cooling refrigeration circuit 24 comprises at least one pre-cooling compressor 70 for compressing the pre-cooling refrigeration fluid PRF and at least one pre-cooling expansion member 72 for expanding the pre-cooling refrigeration fluid PRF. Each releasing heat exchanger 34 is preferably fluidly connected in series between a pre-cooling compressor 70 and a pre-cooling expansion member 72.

[0057] The pre-cooling refrigeration circuit 24 comprises for example at least one pre-cooling condenser 74, each pre-cooling condenser 74 being fluidly connected in series between a pre-cooling compressor 70 and a pre-cooling expansion member 72.

[0058] The pre-cooling refrigeration circuit 24 comprises for example a pre-cooling condenser 74 and a releasing heat exchanger 34 fluidly connected in series between a pre-cooling compressor 70 and a pre-cooling expansion member 72.

[0059] In such case, the releasing heat exchanger 34 is preferably downstream the pre-cooling condenser 74. In a variant, the releasing heat exchanger 34 is upstream the pre-cooling condenser 74

[0060] The pre-cooling refrigeration circuit 24 comprises for example several refrigeration loops 76, each refrigeration loop 76 comprising a respective pre-cooling compressor 70, a respective pre-cooling expansion member 72 and a respective pre-cooling heat exchanger 28.

[0061] The refrigeration loops 76 are preferably configured in cascade such that the pre-cooling expansion member 72 of each following refrigeration loop 76 is fed with a liquid fraction of the pre-cooling refrigeration fluid PRF exiting the pre-cooling heat exchanger 28 of the preceding refrigeration loop 76 and the outlet of the pre-cooling compressor 70 of each following refrigeration loop 76 feeds the inlet of the pre-cooling compressor 70 of the preceding refrigeration loop 76.

[0062] The pre-cooling expansion member 72 of each following refrigeration loop 76 is connected to the preceding refrigeration loop 76 via a liquid/gas separator 78 configured such that a liquid fraction of the pre-cooling refrigeration fluid PRF is fed to the pre-cooling expansion member 72 of said following refrigeration loop 76 and a gaseous fraction of the pre-cooling refrigeration fluid PRF is fed to the inlet of the pre-cooling compressor 70 of the preceding refrigeration loop 76.

[0063] The feed gas line 26 passes for example successively in series via the pre-cooling heat exchangers 28 of the refrigeration loops 76, preferably with passing from the pre-cooling heat exchanger 28 of each previous refrigeration loop 76 to the pre-cooling heat exchanger 28 of the next refrigeration loop 76 in the series of refrigeration loops 76.

[0064] The pre-cooling refrigeration circuit 24 comprises for example a release heat exchanger 34 fluidly connected in series in the first refrigeration loop 76 of the pre-cooling refrigeration circuit 24, preferably between the pre-cooling compressor 70 and the pre-cooling expansion member 72 of said first refrigeration loop 76, with optionally a pre-cooling condenser 74 fluidly connected in series in the first refrigeration loop 76 between the pre-cooling compressor 70 and the pre-cooling expansion member 72, preferably upstream the release heat exchanger 34.

[0065] The pre-cooling compressors 70 of the refrigeration loops 76 are for example separate compressors or preferably distinct stages of a same compressor.

[0066] Each pre-cooling compressor 70 is mechanically coupled to an electric motor 82 and/or a gas turbine 84 for driving the pre-cooling compressor 70.

[0067] The electric motor 82 is for example fed with electric energy provided by the electricity providing unit 52.

[0068] In a preferred example, each pre-cooling compressor 70 is mechanically coupled to gas turbine 84. The use of a gas turbine 84 is advantageous in this situation as gas for the gas turbine 84 is easily accessible in the LNG production facility. The gas turbine 84 is fed by a gas stream C.

[0069] When the pre-cooling refrigeration circuit 24 comprises several pre-cooling compressors 70 defined by distinct stages of a same compressor, the pre-cooling compressors 70 are driven by a same electric motor 82 and/or a same gas turbine 84.

[0070] When the pre-cooling refrigeration circuit 24 comprises several separate pre-cooling compressors 70, the pre-cooling compressors 70 are mechanically coupled to a same electric motor 82 or to respective electric motors 82 and/or mechanically coupled to a same gas turbine 84 or to respective gas turbines 84.

[0071] As illustrated on Figure 2, the pre-cooling refrigeration circuit 24 is advantageously thermally coupled to a liquefaction refrigeration fluid line 86 of the liquefaction unit 20. The liquefaction fluid line 86 is configured for the circulation of a liquefaction refrigeration fluid LRF

used the liquefaction unit 20 for generating cold and transferring said cold to the feed gas G. The liquefaction refrigeration fluid LRF is for example methane, ethylene, propan, nitrogen or a mix of two or more among methane, ethylene, propane and nitrogen.

[0072] The pre-cooling refrigeration circuit 24 is for example thermally coupled to the liquefaction refrigeration fluid line 86 via one or several heat exchangers, in particular one or several pre-cooling heat exchangers 28.

[0073] Preferably, when the pre-cooling refrigeration circuit 24 comprises several refrigeration loops 76, each refrigeration loop 76 is for example thermally coupled to the liquefaction refrigeration fluid line 86 via one heat exchanger, in particular the pre-cooling heat exchangers 28 arranged in said refrigeration loop 76.

[0074] In operation, the feed gas received in the LNG production installation 10 is optionally purified in the purification unit 16, pre-cooled in the pre-cooling unit 18 and then liquefied in the liquefaction unit 20.

[0075] The LNG production installation 10 is configured for implementing a method of pre-cooling the feed gas G, the method comprising the steps of:

- producing cold in the pre-cooling refrigeration circuit 24 with operating a refrigeration cycle with the pre-cooling refrigeration fluid PRF and transferring the cold from the pre-cooling refrigeration fluid PRF to the feed gas G via one or more pre-cooling heat exchanger 28 ; and
- producing cold in the sub-cooling refrigeration circuit 32 with operating a refrigeration cycle with the sub-cooling refrigeration fluid SRF and transferring cold from the sub-cooling refrigeration fluid SRF to the pre-cooling refrigeration fluid PRF.

[0076] The pre-cooling refrigeration circuit 24 is preferably operated continuously when the LNG production facility 10 is in operation.

[0077] The pre-cooling refrigeration fluid PRF is circulated in the pre-cooling refrigeration circuit 24 with being compressed in each pre-cooling compressor 70, condensed in each pre-cooling condenser (if provided), expanded in each pre-cooling expansion member 72.

[0078] The pre-cooling refrigeration fluid PRF circulates in each releasing heat exchange 34 with retrieving cold and circulates in each pre-cooling heat exchanger 28 with cooling the feed gas G and, optionally, a liquefaction refrigeration fluid LRF.

[0079] The production of cold with the sub-cooling refrigeration circuit 32 is operated continuously or intermittently, e.g. as a function of availability of the energy provided by an energy production device using one or several renewable energy sources for production electrical energy.

[0080] The transfer of cold from the sub-cooling refrigeration fluid SRF to the pre-cooling refrigeration fluid PRF is operated via the releasing heat exchanger 34.

[0081] Preferably, the transfer of cold from the sub-

cooling refrigeration fluid SRF to the pre-cooling refrigeration fluid PRF is operated via the heat transfer circuit 36 configured for circulation of the heat transfer fluid HTF, the heat transfer circuit 36 being thermally coupled with the sub-cooling refrigeration circuit 32 via the collecting heat exchanger 38 and thermally couple with the pre-cooling refrigeration circuit 24 via the releasing heat exchanger 34.

[0082] During operation of the sub-cooling refrigeration circuit 32, the sub-cooling refrigeration fluid SRF circulates successively in the sub-cooling compressor 60, the sub-cooling condenser 62, the sub-cooling expansion member 64 and the collecting heat exchanger 38 before returning to the sub-cooling compressor 60.

[0083] The sub-cooling refrigeration fluid SRF is compressed in the sub-cooling compressor 60, then condensed in the sub-cooling condenser 62, then expanded in the sub-cooling expansion member 64 and then evaporated in the collecting heat exchanger 38.

[0084] After expansion in the sub-cooling expansion member 64, the sub-cooling refrigeration fluid SRF is in gaseous state and cold. When passing in the collecting heat exchanger 38, the sub-cooling refrigeration fluid SRF releases cold to the heat transfer fluid HTF before returning to the compressor 60.

[0085] When the sub-cooling refrigeration circuit 32 is operating, the method comprises for example the step of storing cold produced by the sub-cooling refrigeration circuit 32, in particular in the heat transfer circuit 36.

[0086] When the heat transfer circuit 36 comprises one or several tanks, the storage of cold in the heat transfer circuit 36 is operated by circulating heat transfer fluid HTF to a tank via the collecting heat exchanger 38.

[0087] In particular, when the heat transfer circuit 36 comprises the first tank 40 and the second tank 42, the storage of cold in the heat transfer circuit 36 is by transferring heat transfer fluid HTF from the first tank 40 to the second tank 42 via the collecting heat exchanger 38.

[0088] The method comprises the release of cold from the heat transfer circuit 36 to the pre-cooling refrigeration fluid PRF, preferably continuously if the pre-cooling refrigeration circuit is operated continuously.

[0089] The step of releasing cold is operated by circulating the heat transfer fluid HTF via the releasing heat exchanger 34.

[0090] When the heat transfer circuit 36 comprises one or several tanks, the release of cold is operated by circulating heat transfer fluid HTF from a tank storing the cold heat transfer fluid HTF to the collecting heat exchanger 38.

[0091] In particular, when the heat transfer circuit 36 comprises the first tank 40 and the second tank 42, the release of cold is operated by transferring heat transfer fluid HTF from the second tank 42 to the first tank 40 via the releasing heat exchanger 38.

[0092] Owing to the invention, it is possible to generate cold efficiently in the sub-cooling refrigeration circuit 30 and to transfer this cold to the pre-cooling refrigeration

circuit 24 for increasing the overall efficiency of the pre-cooling unit 18.

[0093] Each compressor 70 of the pre-cooling refrigeration circuit 24 can be operated easily, e.g. using a gas turbine 84 which uses gas for producing mechanical energy, the gas being easily accessible in the LNG production facility.

[0094] The sub-cooling refrigeration circuit 32 can be operated with using other sources of energy for enhance efficiently, and in particular with using an electrical sub-cooling compressor 60, in particular associated to an renewable electricity production device 56 using one or several renewable energy sources for generating electricity.

[0095] The production of cold in a sub-cooling refrigeration circuit 32 separate from the pre-cooling refrigeration circuit 24 and the transfer of the cold to the pre-cooling refrigeration circuit 24 allows accounting for potential intermittency of renewable energy sources used for operating the sub-cooling refrigeration circuit 32.

[0096] The pre-cooling refrigeration circuit 24 can be kept operating continuously whilst the sub-cooling refrigeration circuit 32 can be operated intermittently.

[0097] The transfer of cold from the sub-cooling refrigeration circuit 32 to the pre-cooling refrigeration circuit 24 via a heat transfer circuit 36 allows a buffering for accounting for the intermittency of the operation of the sub-cooling refrigeration circuit 30, with a storage of cold in the heat transfer circuit 36, i.e. storing cold produced in excess by the sub-cooling refrigeration circuit 32 when the sub-cooling refrigeration circuit 32 is in operation and releasing said cold to the pre-cooling refrigeration circuit 24, e.g. when the sub-cooling refrigeration circuit 32 is not operating or produces not enough cold.

[0098] The heat transfer circuit 36 provided with at least one tank and preferably two tanks allows timing the circulation of the heat transfer fluid HTF in heat transfer circuit 36 for collecting cold and releasing cold.

[0099] In particular, the provision of two separate tanks and two pumps allows collecting cold and releasing cold simultaneously, potentially with different flow rates of the heat transfer fluid HTF from the first tank to the second tank and from the second tank to the first tank.

[0100] In addition, the provision of two separate tanks, one for storing a cold fraction of heat transfer fluid and the other for storing the hot fraction of the heat transfer fluid, avoids a mixing of the hot fraction and the cold fraction as it would occur with one single tank storing the cold fraction and the hot fraction in a stratified manner, in particular when the flow rate of heat transfer fluid exiting such a tank and the flow rate of heat transfer fluid returning to such a tank are different.

Claims

1. Pre-cooling unit for a liquefied natural gas production facility configured for producing liquefied natural gas

from a feed gas containing methane, the pre-cooling unit comprising :

- a pre-cooling refrigeration circuit (24) for producing cold with circulation of a pre-cooling refrigeration fluid, the pre-cooling refrigeration circuit (24) being thermally coupled to a feed gas line via one or more pre-cooling heat exchanger for transferring cold from the refrigeration fluid to the feed gas; and
- a sub-cooling unit (30) comprising a sub-cooling refrigeration circuit (32) for producing cold with circulation of sub-cooling refrigeration fluid, the sub-cooling refrigeration circuit (32) being thermally couple to the pre-cooling refrigeration circuit (24) for transferring cold from the sub-cooling refrigeration circuit (32) to the pre-cooling refrigeration circuit (24).

2. The pre-cooling unit as in claim 1, wherein the sub-cooling refrigeration circuit (32) is thermally coupled to the pre-cooling refrigeration circuit (24) via a releasing heat exchanger (34).
3. The pre-cooling unit as in claim 1 or 2, wherein the sub-cooling refrigeration circuit (32) is thermally coupled to the pre-cooling refrigeration circuit (24) a heat transfer circuit (36) configured for circulation of a heat transfer fluid, the heat transfer circuit (36) being thermally coupled with the sub-cooling refrigeration circuit (32) via a collecting heat exchanger (38) for collecting cold from the sub-cooling refrigeration circuit (32) and thermally coupled with the pre-cooling refrigeration circuit (24) via a releasing heat exchanger (34) for releasing cold to the pre-cooling refrigeration fluid (24).
4. The pre-cooling unit as in claim 3, wherein the heat transfer circuit (36) comprises at least one tank (40, 42) for storing the heat transfer fluid and at least one pump (44, 46) for circulating the heat transfer fluid from the tank (40, 42) to the collecting heat exchanger (38) and/or the releasing heat exchanger (34).
5. The pre-cooling unit as in claim 3 or 4, wherein the heat transfer circuit (36) comprises a first tank (40) for storing the heat transfer fluid, a second tank (42) for storing heat transfer fluid and a least one pump (44, 46) for selectively circulating the heat transfer fluid from the first tank (40) to the second tank (42) via the collecting heat exchanger (38) or circulating the heat transfer fluid from the second tank (42) to the first tank (40) via the releasing heat exchanger (34).
6. The pre-cooling unit as in claim 5, wherein the heat transfer circuit (36) comprises a first pump (44) for circulating the heat transfer fluid from the first tank (40) to the second tank (42) via the collecting heat

- exchanger (38) and a second pump (46) for circulating the heat transfer fluid from the second tank (42) to the first tank (40) via the releasing heat exchanger (34), the first pump (44) and the second pump (46) being distinct.
7. The pre-cooling unit as in claim 6, configured for activating the first pump (44) intermittently and for activating the second pump (46) continuously during operation of the pre-cooling unit (18).
8. The pre-cooling unit as in one of the preceding claims, wherein the sub-cooling unit (30) is connected to an electricity producing unit (52) configured for producing electrical energy, in particular from one or several renewable energy sources, and feeding the sub-cooling unit (30) with said electrical energy for operation of the sub-cooling unit (30).
9. The pre-cooling unit as in any one of the preceding claims, wherein the heat transfer fluid is water or a mix of water and glycol and/or the sub-cooling refrigeration fluid contains propane and/or butane, and is for example propane, butane or a propane/butane mix, in particular a propane/butane mix containing at least 50wt% of propane, preferably 60wt% of propane, in particular between 65 wt% and 75 wt% of propane.
10. The pre-cooling unit as in any one of the preceding claims, wherein the pre-cooling refrigeration circuit (24) comprises one or several compressors (70), the releasing heat exchanger (34) being arranged in the pre-cooling refrigeration circuit (24) between one of said one or several compressors (70) and an expansion member (72).
11. The pre-cooling unit as in any one of the preceding claims, wherein the pre-cooling refrigeration circuit (24) comprises several refrigeration loops (76), each refrigeration loop (76) comprising a compressor (70), the compressors of the refrigeration loops (76) being for example distinct stages of a same common compressor.
12. The pre-cooling unit as in claim 10 or 11, comprising a gas turbine (84) mechanically coupled to the compressor(s) (70) of the pre-cooling refrigeration circuit (24) for driving the compressor(s) of the pre-cooling refrigeration circuit (24).
13. A liquefied natural gas production facility configured for producing liquefied natural gas from a feed gas containing methane, the liquefied natural gas production facility comprising the precooling unit as in any one of the preceding claims.
14. A method of pre-cooling unit feed gas in a liquefied natural gas production facility configured for producing liquefied natural gas from the feed gas, the feed gas containing methane, the method comprising :
- producing cold in a pre-cooling refrigeration circuit (24) with a pre-cooling refrigeration fluid and transferring the cold from the pre-cooling refrigeration fluid to the feed gas via one or more pre-cooling condensers (28);
 - producing cold in a sub-cooling refrigeration circuit (32) with a sub-cooling refrigeration fluid and transferring cold from the sub-cooling refrigeration circuit (32) to the pre-cooling refrigeration circuit (24).
15. The method of pre-cooling unit feed gas as in claim 16, wherein the transfer of cold from the sub-cooling refrigeration circuit (32) to the pre-cooling refrigeration circuit (24) is operated via a heat transfer circuit (36) configured for circulation of a heat transfer fluid, the heat transfer circuit being thermally coupled with the sub-cooling refrigeration circuit (32) via a collecting heat exchanger (38) and thermally couple with the pre-cooling refrigeration circuit (24) via a releasing heat exchanger (34).

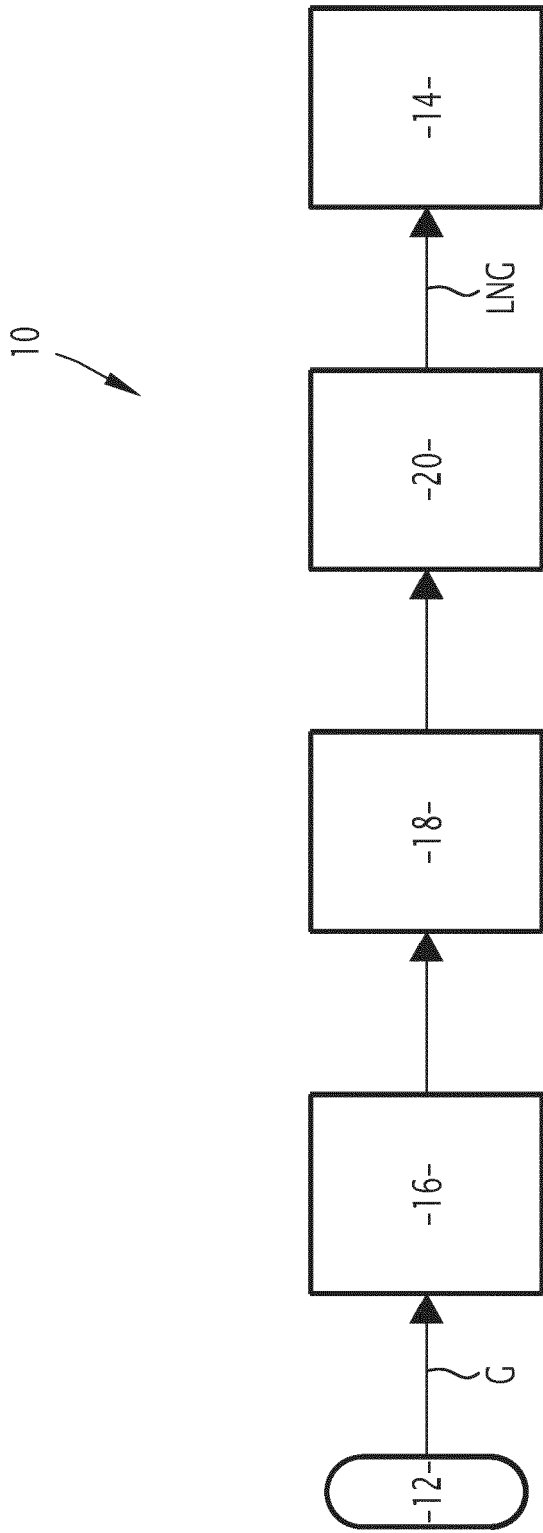

FIG.1

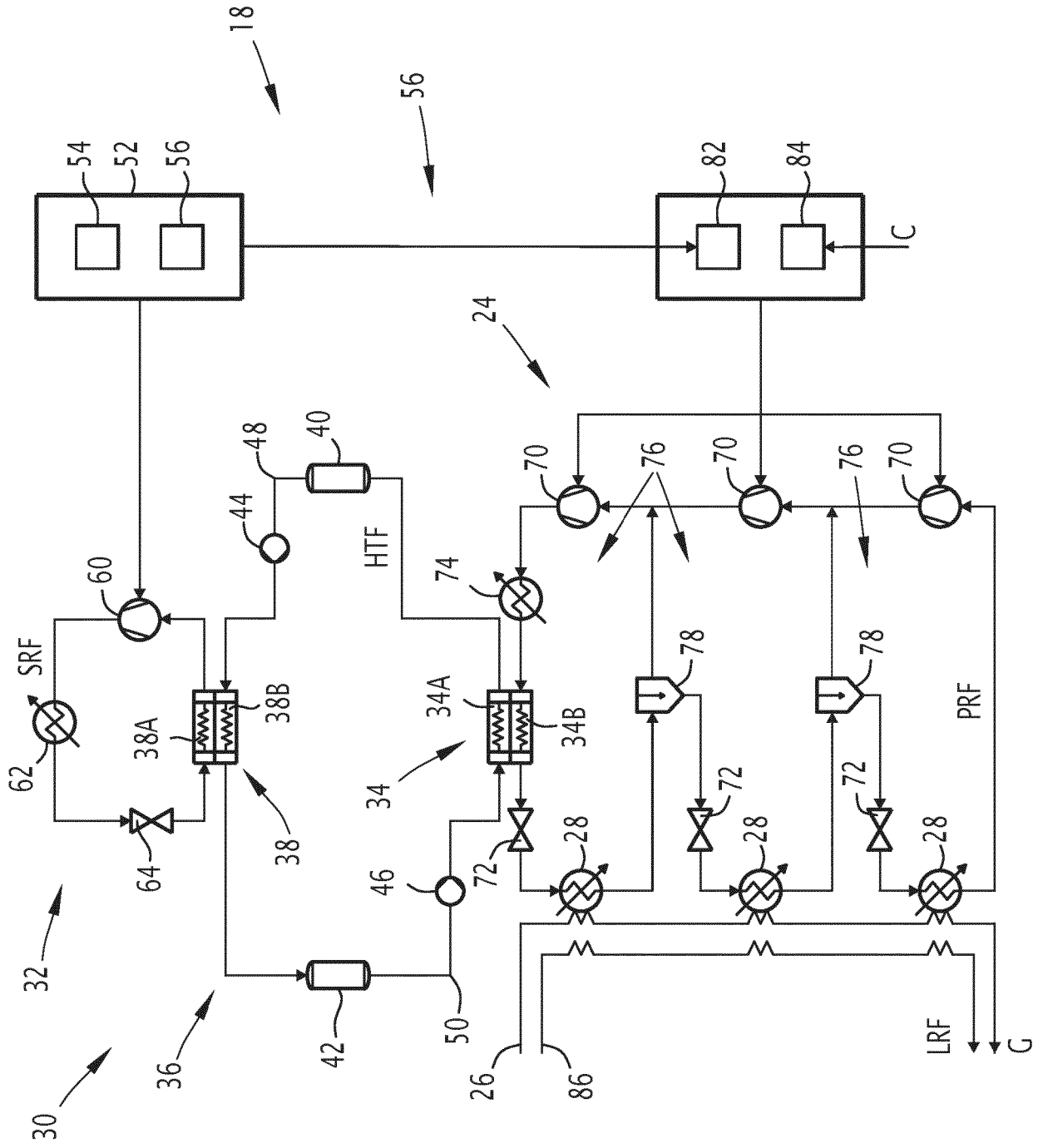

FIG. 2



EUROPEAN SEARCH REPORT

Application Number
EP 23 30 6259

5

DOCUMENTS CONSIDERED TO BE RELEVANT

10

15

20

25

30

35

40

45

50

55

Category	Citation of document with indication, where appropriate, of relevant passages	Relevant to claim	CLASSIFICATION OF THE APPLICATION (IPC)
X	WO 2008/136121 A1 (HITACHI LTD [JP]; HITACHI PLANT TECHNOLOGIES LTD [JP] ET AL.) 13 November 2008 (2008-11-13) * page 4; figure 1 *	1-15	INV. F25J1
X	WO 2020/245510 A1 (TOTAL SE [FR]) 10 December 2020 (2020-12-10) * figure 1 *	1, 13, 14	
A	WO 2022/147385 A1 (EXXONMOBIL UPSTREAM RES CO [US]) 7 July 2022 (2022-07-07) * figures 1-6 *	1-15	
			TECHNICAL FIELDS SEARCHED (IPC)
			F25J
The present search report has been drawn up for all claims			
Place of search Munich		Date of completion of the search 12 January 2024	Examiner Schopfer, Georg
CATEGORY OF CITED DOCUMENTS		T : theory or principle underlying the invention E : earlier patent document, but published on, or after the filing date D : document cited in the application L : document cited for other reasons & : member of the same patent family, corresponding document	
X : particularly relevant if taken alone Y : particularly relevant if combined with another document of the same category A : technological background O : non-written disclosure P : intermediate document			

EPO FORM 1503 03.82 (P04C01)

**ANNEX TO THE EUROPEAN SEARCH REPORT
ON EUROPEAN PATENT APPLICATION NO.**

EP 23 30 6259

5 This annex lists the patent family members relating to the patent documents cited in the above-mentioned European search report.
The members are as contained in the European Patent Office EDP file on
The European Patent Office is in no way liable for these particulars which are merely given for the purpose of information.

12-01-2024

Patent document cited in search report	Publication date	Patent family member(s)	Publication date
WO 2008136121 A1	13-11-2008	JP 5048059 B2	17-10-2012
		JP WO2008136121 A1	29-07-2010
		WO 2008136121 A1	13-11-2008

WO 2020245510 A1	10-12-2020	NONE	

WO 2022147385 A1	07-07-2022	NONE	

EPO FORM P0459

For more details about this annex : see Official Journal of the European Patent Office, No. 12/82