

D. A. FLUMERFELT.  
Dryer for Grain, &c.

No. 206,431.

Patented July 30, 1878.

Fig. 1.

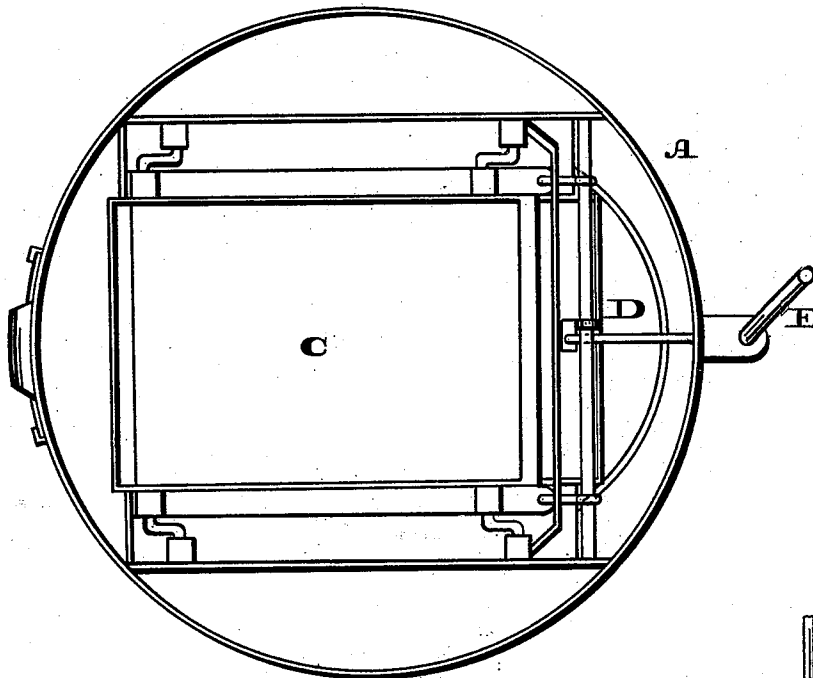
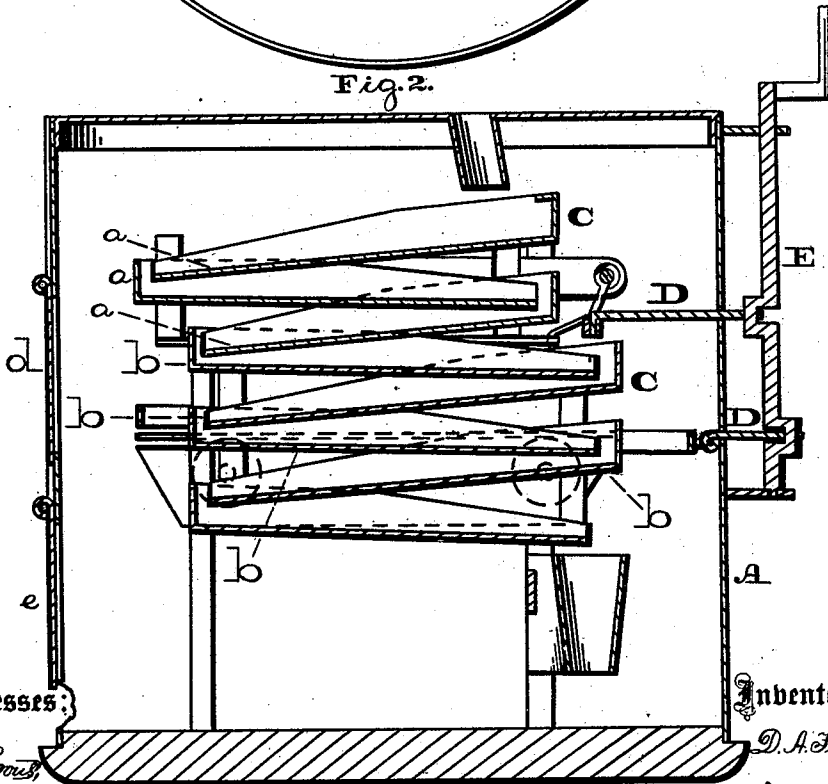

Fig. 2.



Witnesses:

Lewis F. Booth,  
J. P. Grant.

Inventor:

D. A. Flumerfelt,

by John A. Diercksheim & Co.

ATTORNEYS.

# UNITED STATES PATENT OFFICE.

DANIEL A. FLUMERFELT, OF DELAWARE STATION, NEW JERSEY, ASSIGNOR OF TWO-THIRDS HIS RIGHT TO WM. F. AND JAMES HUTCHISON, OF SAME PLACE.

## IMPROVEMENT IN DRIERS FOR GRAIN, &c.

Specification forming part of Letters Patent No. **206,431**, dated July 30, 1878; application filed December 20, 1877.

*To all whom it may concern:*

Be it known that I, DANIEL A. FLUMERFELT, of Delaware Station, in the county of Warren and State of New Jersey, have invented a new and useful Improvement in Driers for Grain and other articles, which improvement is fully set forth in the following specification and accompanying drawings, in which—

Figure 1 is a top or plan view of the inside of the drier embodying my invention. Fig. 2 is a central vertical section thereof.

Similar letters of reference indicate corresponding parts in the two figures.

My invention consists of a portable drying-chamber, within which is a drying apparatus and a series of pans, alternately inclined in opposite directions, the adjacent series reciprocating in reverse order, whereby the article to be dried will be caused to traverse the lengths of the several pans, and to be continually turned, so that it will be quickly and thoroughly dried. By this construction, also, the drier will occupy but small space laterally, and it may be readily enlarged by multiplying the number of pans without increasing the width of the chamber.

Referring to the drawings, A represents the drying-chamber, and B the base thereof. C represents reciprocating pans, formed in series *a a a* and *b b b*, each series being connected so as to move as one, and all are properly supported within the chamber A. The pans of each series incline in opposite directions, and they are open at alternate ends, and the series are suspended from hangers mounted on rollers fitted to ledges, or rested on ways properly elevated, applied, or secured, whereby the pans will be guided in their motions.

To the rock-shaft to which the suspended pans are connected, or arms secured to the pans, which are mounted on rollers, or otherwise supported, there are attached arms D, connected to a vertical shaft, E, which is suitably mounted, and this shaft E may be pro-

vided with eccentrics or cranks, so arranged that the arms will be alternately operated, only a single shaft being necessary.

It will be seen that when the shaft E receives power it will cause the two series *a b* of the pans to slide or move horizontally in opposite directions.

Steam, hot air, or other medium may be employed for drying purposes.

The grain or other articles are introduced into the chamber A through a suitable funnel on top, and it drops on the first pan, *a*, of the series C, thence runs the length thereof and drops on the second pan, where it runs in reversed direction until it reaches the end of said second pan, and it then falls on the third pan of the series, after which it drops on the second series and runs the lengths of the several reversely-inclined pans thereof, and then falls into a chute, conveyer, or other means of directing the articles to a place of deposit or otherwise.

It will be seen that as the articles are subjected to the drying influence of the chamber A, and they pass over the several inclined pans, the series whereof are reciprocated in reverse order, it is evident that the articles will be thoroughly agitated and turned and overturned while traversing a great extent on their way from the point of admission to and departure from the pans. Access is had to the pans from the side of the chamber by means of a door or slide, *d*, and to the heating or drying medium below the pans by a door or slide, *e*, both properly applied. The number of series of pans may be multiplied; but this will enlarge the apparatus without increasing the width thereof, the apparatus being portable, compact, easily operated, and cheaply constructed.

Suitable dampers may be provided to regulate the drying medium, and permit the discharge of vapors from the damp grain or other article operated upon.

This apparatus is admirably adapted for

drying buckwheat, as its nature is such that it requires excessive agitation during the drying process.

Having thus described my invention, what I claim as new, and desire to secure by Letters Patent, is—

The portable drier consisting of the chamber A, containing the series of pans C, oper-

ated as described, supporting the operating mechanism of the pans, and containing the drying apparatus, substantially as and for the purpose set forth.

DANIEL A. FLUMERFELT.

Witnesses:

JOHN A. WEIDERSHEIM,  
H. E. HINDMARSH.