

(19) World Intellectual Property Organization
International Bureau



(43) International Publication Date
22 March 2007 (22.03.2007)

PCT

(10) International Publication Number
WO 2007/033342 A2

- (51) International Patent Classification:
A61F 5/00 (2006.01)
- (21) International Application Number:
PCT/US2006/035895
- (22) International Filing Date:
14 September 2006 (14.09.2006)
- (25) Filing Language: English
- (26) Publication Language: English
- (30) Priority Data:
60/717,105 14 September 2005 (14.09.2005) US
11/531,460 13 September 2006 (13.09.2006) US
- (71) Applicant (for all designated States except US): **POLY-
WORKS, INC.** [US/US]; 1 Tupperware Drive, North
Smithfield, RI 02896 (US).
- (72) Inventors: **LAFLAMME, Roger, J.**; 3 Hoover Lane, En-
field, CT 06082 (US). **FOX, Richard, B.**; 362 Log Road,
Smithfield, RI 02917 (US).
- (74) Agents: **JOSEPHS, David, R.** et al.; Barlow, Josephs &
Holmes, Ltd., 101 Dyer Street, 5th Floor, Providence, RI
02903 (US).

- (81) Designated States (unless otherwise indicated, for every
kind of national protection available): AE, AG, AL, AM,
AT, AU, AZ, BA, BB, BG, BR, BW, BY, BZ, CA, CH, CN,
CO, CR, CU, CZ, DE, DK, DM, DZ, EC, EE, EG, ES, FI,
GB, GD, GE, GH, GM, HN, HR, HU, ID, IL, IN, IS, JP,
KE, KG, KM, KN, KP, KR, KZ, LA, LC, LK, LR, LS, LT,
LU, LV, LY, MA, MD, MG, MK, MN, MW, MX, MY, MZ,
NA, NG, NI, NO, NZ, OM, PG, PH, PL, PT, RO, RS, RU,
SC, SD, SE, SG, SK, SL, SM, SV, SY, TJ, TM, TN, TR,
TT, TZ, UA, UG, US, UZ, VC, VN, ZA, ZM, ZW.
- (84) Designated States (unless otherwise indicated, for every
kind of regional protection available): ARIPO (BW, GH,
GM, KE, LS, MW, MZ, NA, SD, SL, SZ, TZ, UG, ZM,
ZW), Eurasian (AM, AZ, BY, KG, KZ, MD, RU, TJ, TM),
European (AT, BE, BG, CH, CY, CZ, DE, DK, EE, ES, FI,
FR, GB, GR, HU, IE, IS, IT, LT, LU, LV, MC, NL, PL, PT,
RO, SE, SI, SK, TR), OAPI (BF, BJ, CF, CG, CI, CM, GA,
GN, GQ, GW, ML, MR, NE, SN, TD, TG).

Published:
— without international search report and to be republished
upon receipt of that report

For two-letter codes and other abbreviations, refer to the "Guidance Notes on Codes and Abbreviations" appearing at the beginning of each regular issue of the PCT Gazette.

(54) Title: GEL RE-COIL PAD

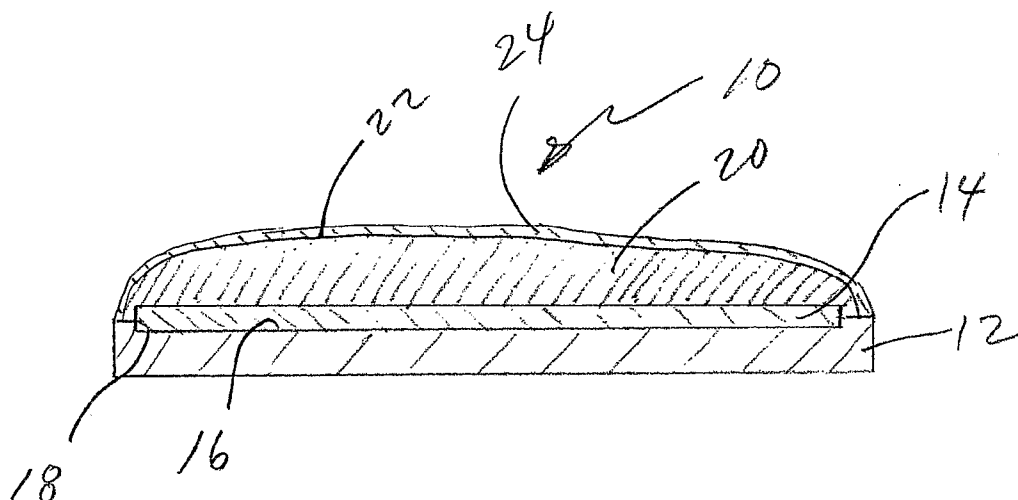

(57) **Abstract:** The invention is generally directed to a new and novel cushioning pad construction that has particular application as a firearm re-coil pad (10). The construction includes a gel material (20) to serve as its primary cushioning material. The pad construction (10) of the present invention includes a plastic molded base member (12) that is preferably sized to the object to be cushioned. A bond-promoting fabric layer (14) is either adhered onto or insert molded into the front face (16) of the base member (12). A low durometer gel material (20) is molded onto fabric layer (14) to bond to the plastic base member (12). A finish coating layer (24) is applied, such as by spraying or dip coating, onto the gel cushioning layer (20) to finish the novel re-coil pad construction (10).

WO 2007/033342 A2

GEL RE-COIL PAD

CROSS-REFERENCE TO RELATED APPLICATIONS

[01] This application claims priority from prior U.S. Provisional Application Serial No. 60/717,105 filed on September 14, 2005.

BACKGROUND OF THE INVENTION

[02] The present invention generally relates to devices and apparatus for cushioning objects. More specifically, the present invention relates to re-coil pads that are suitable for cushioning the impact of other objects, such as firearms, or the like.

[03] In prior art, cushioning pads are well known in the prior art to reduce the impact forces imparted from one object to another. More specifically, cushioning pads have been provided to reduce the impact forces from an object to a person in contact with that object and from one object to another object.

[04] For example, it is widely recognized by firearm users that when a firearm is discharged, it produces a considerable amount of energy which is transmitted back to the user in the form of re-coil. This is particularly evident in the higher caliber rifles used by sportsmen. Re-coil pads, also known as a butt pad, are well-known accessories for the purposes of protecting the rear face of the stock of the firearm to prevent damage thereto and to make the discharge of a fire arm more comfortable to the user. More

specifically, when made of a less rigid material, such as rubber, the re-coil pad can effectively absorb a portion of the re-coil force from a re-coil event thus reducing the discomfort often felt in the shoulder of the shooter.

[05] Many different structures have been used in the prior art to provide cushioning. In addition to rubber mentioned above, foams and other padding materials can be used. However, these materials are inadequate to provide the needed impact cushioning, such as that needed in the firearm industry, while providing the required control and interface to the user. Also, liquids, such as very viscous fluids, have been enclosed in a bag-like construction to provide a cushioning structure. However, these constructions are awkward to manufacture, are susceptible to puncture, provide a poor interface to the user and are difficult to form into complex configurations and geometries.

[06] There have been efforts to specifically address the needs of cushioning in the firearm industry. Conventional approaches in the effort to reduce the discomfort experienced from re-coil from firearms have revolved mainly around pads, or other devices, which are permanently attached to the rifle buttstock. These devices are limited to the dimension of the buttstock for practical and aesthetic reasons. Many require considerable modification to install, particularly

those devices which are mechanical in nature. Even the simplest re-coil pad often requires custom fitting to the buttstock, resulting in considerable cost of time and/or expense.

[07] Although many existing re-coil pads achieve their primary goal with some effectiveness, their scope is confined by design and construction limitations. Some slip-on, or boot type pads exist, which utilize tight-fitting rubber sleeves for attachment to the buttstock. The end of the boot defines a rear compartment which is occupied by air, or various other materials.

[08] Furthermore, all re-coil devices for attachment to firearms heretofore known suffer from a number of disadvantages. First, existing pads limit themselves to the approximate dimension of the buttstock of the firearm. This limitation results in the re-coil force from the discharge of the firearm being transmitted to the user in a narrowly defined area of the shoulder. Second, existing re-coil pads, both permanent and those of the boot type, have been designed with the consideration they will basically be permanently left attached to the firearm with their outer surfaces being made of tough, abrasion-resistant material having a disadvantage of a limited amount, and thickness, of soft shock-absorbing material that has been used in the pads. Third, existing re-coil pad are basically designed to be permanently attached to

the firearm and do not offer the option to change the pad to suit differing shooting conditions.

[09] Therefore, there is a need for a re-coil pad that effectively cushions the shooters shoulder during firing to avoid injury to the shooter and make the shooting experience more enjoyable. There is a further need for a highly cushioned re-coil pad that is softer and more comfortable than prior art pads yet is still effectively in absorbing re-coil without sacrificing shooting accuracy. There is another need for a re-coil pad that is easily removable from the buttstock of a firearm so that it can be replaced if necessary. There is a need for a re-coil pad that has a removable construction that does not damage the integrity of the pad itself. There is yet a further need for a re-coil pad that has an attractive outer appearance.

SUMMARY OF THE INVENTION

[10] The present invention preserves the advantages of prior art cushioning pads, such as those used for reducing the impact of firearm re-coil to a user. In addition, it provides new advantages not found in pads and cushioning devices and overcomes many disadvantages of such currently available pads and devices.

[11] The invention is generally directed to a new and novel re-coil pad construction that includes a gel material as its primary cushioning material. The pad

construction of the present invention includes a preferably plastic molded base substrate that is preferably sized to the object to be cushioned. A bond-promoting fabric layer is either adhered onto or inserted molded into the front face of the base substrate. A low durometer gel material is molded onto fabric layer to bond to the plastic substrate. A coating is sprayed onto the gel cushioning layer to finish the novel re-coil pad construction. While plastic is the preferred material for the base member, other materials may be used.

[12] The present invention can be used in any environment where cushioning is required to reduce the effects of an impact. While it has particular application as a re-coil pad for firearms, it is in no way intended that the scope of this application be limited to such an application of use.

[13] It is therefore an object of the present invention to provide a re-coil pad that effectively reduces the effect and cushions the effect of an impact of an object to a user.

[14] It is therefore an object of the present invention to provide a re-coil pad that effectively cushions the shooters shoulder during firing to avoid injury to the shooter and make the shooting experience more enjoyable.

[15] There is a further object of the present invention to provide a highly cushioned re-coil pad that is

softer and more comfortable than prior art pads yet is still effectively in absorbing re-coil with sacrificing shooting accuracy.

[16] There is another object of the present invention to provide a re-coil pad that is easily removable from the buttstock of a firearm so that it can be replaced if necessary.

[17] There is yet a further object of the present invention to provide a re-coil pad that has a removable construction that does not damage the integrity of the pad itself.

[18] Another object of the present invention is to provide a re-coil pad that has an attractive outer appearance.

BRIEF DESCRIPTION OF THE DRAWINGS

[19] The novel features which are characteristic of the present invention are set forth in the appended claims. However, the invention's preferred embodiments, together with further objects and attendant advantages, will be best understood by reference to the following detailed description taken in connection with the accompanying drawings in which:

[20] Fig. 1 cross-sectional view of a re-coil pad manufactured in accordance with the present invention with the bond promoting fabric layer molded into the base member;

[21] Fig. 2 is a cross-sectional view of a re-coil pad manufactured in accordance with the present invention

with the bond promoting fabric layer affixed to the top of the base member; and

[22] Fig. 3 is a cross-sectional view of a re-coil pad manufactured in accordance with the present invention for use in a firearm buttstock environment to reduce firearm re-coil.

DETAILED DESCRIPTION OF THE PREFERRED EMBODIMENT

[23] Referring first to Fig. 1, a cross-sectional view of the new and novel re-coil pad 10 of present invention is shown. More specifically, the invention shown in Fig. 1 shows the preferred general construction of the present invention. A base member 12 is provided to serve as a support substrate for the pad construction 10. Thus base member 12 provides rigidity so that the overall construction of the re-coil pad 10 is maintained as desired. It is preferred that the base member 12 is made of plastic for ease of manufacture and to permit complex geometries to be easily formed, as desired. For example, plastic is preferably used for the base member 12.

[24] A bond promoting layer 14 is placed into communication with the top surface 16 of the base member 12. Porous fabric is preferably used for this bond promoting layer 14. Preferably, as seen in Fig. 1, the bond promoting layer 14 embedded into the top face 16 of the base member 12. This is most effectively accomplished by insert molding the fabric bond promoting layer 14 into the top face 16 of the

plastic base member 12 during molding of the base member 12 itself. Thus, the bottom portion of fabric layer 14 is embedded into the plastic base member 12 while the upper portion of the fabric 14 is free to receive other material, as will be described below, to help adhere the other material securely to the base member 12.

[25] It is also possible that a seat 18 is formed in the base member 12 during the molding process whereby the fabric layer 14 is adhered therein by use of adhesives, and the like (not shown). Still further, the bond promoting fabric layer 14 may be adhered directly to the top surface 16 of the base member 12, as seen in Fig. 2.

[26] Next, a low durometer gel material 20 is molded over the base member 12 with the fabric bond promoting material 14 captured therebetween. The gel 20 is preferably formed to have a thickness of approximately $\frac{1}{2}$ of an inch to $\frac{3}{4}$ of an inch. Of course, it can be formed of other thicknesses, such as greater than 1 inch to suit the application at hand. In either of the embodiments of Figs. 1 or 2, it can be understood that an upper portion of the fabric layer 14 is exposed. Thus, molding a gel material 20 thereover causes the gel material 20 to embed within the porous fabric material 14 thereby gripping to it. Essentially, the fabric layer 14 causes the receiving surface of the base member 12, which is otherwise

substantially smooth, to be more receptive to securely receive a molded material 20 thereto. The fabric layer 14 effects promotes secured bonding of the gel material 20 to the base member 12.

[27] Turning specifically to the cushioning material 20 that is employed in accordance with the present invention, the preferred gel material 20 is low durometer polyurethane that has a Shore 00 hardness in the range of about 15 to about 45. As stated above, this gel cushioning core 20 is preferably formed by molding, such as by injection molding, including RIM (reactive injection molding) and LIM (liquid injection molding).

[28] For example, as stated above, the gel core 20 is preferably formed by molding about and over the base member 12 that preferably includes the bond promoting fabric material 14 already in place. In certain applications, the gel core 20 can be molded completely about a base member 12. Moreover, soft molds may be used to carry out the present invention, which are described in detail in co-pending and commonly owned U.S. Patent Application Serial No. 11294793, filed on December 6, 2005, which is incorporated herein by reference. These molds significantly reduce the cost of building tooling for molding operations.

[29] This process provides for molding of gel material 20 on and/or about a base member 12 to provide a cushioned impact member. In this process, a first

half and a mating complementary second mold half (not shown) are prepared with a mold release coating and pre-heated. The base member 12 is loaded and seated in place within a cavity on the first mold half then the second mold half is mated with the first mold half to thereby close about the base member 12. Next, the desired cushioning gel material 20, such as urethane with a Shore 00 hardness in the range of about 15 to about 45, is injected therein an input gate (not shown). As can be understood, multiple molds are preferably used to improve production efficiency and increase capacity. The usual curing time is carried out to properly process the low durometer elastomer gel material 20 on the base member 12. The mold is then opened and the base member with the gel material 20 molded thereon is unloaded. The usual spew materials are removed to clean up the molded part.

[30] Unlike the very low durometer and very low density materials employed in the present invention, rubber and higher durometer materials, such as urethanes and high density foams, are used in the prior art. These higher durometer materials do not have the tackiness or long cure times and can thus be molded by standard injection molding processes. Because of the tackiness, the low durometer products need to be molded with no flashing since they cannot be trimmed. Also, they require specialized release coatings in the molds to allow them to come out of the mold and still

be painted. The long cure times of these materials are accommodated by utilizing numerous molds moving in series through the process.

[31] The re-coil pad 10 of the present, using a molded low durometer gel material 20, is unique and novel compared to the prior art because it can provide different profiles of low durometer elastomer on or about the surface of the base member 12. For example, since the gel 20 is molded, it can be profiled to having varying thickness in different regions of the object to be cushioned to improve impact reduction rather than just providing a uniform layer of cushion over the entire surface of the object. For example, it may be desirable to make the gel layer 20 thicker where the object communicates with a sensitive part of the body. Still further, a given area of the re-coil pad 10 may be injected with higher or lower durometer material 20 than other parts of the layer.

[32] After molding of the gel material 20, the outer surface 22 of the low durometer gel material 20 is very sticky and desirably soft to meet the cushioning needs of the user. The pad construction 10 is then finished by applying a finish layer 24 of, preferably, an elastomeric paint. The use of elastomeric paint 24 allows for it to stretch when the gel core 20 flexes due to an impact. This finish layer 24 may be applied to the sticky outer surface 22 of the gel core 20 by spraying or dip coating. The outer layer 24 may also

be a fabric material, depending on the application at hand.

[33] Also, instead of paint or fabric to serve as the finish layer 24, various films (not shown) may be applied to the gel core 20 to further enhance the pad construction 10. For example, a soft outer polyurethane film can be applied to the low durometer elastomer on a pen barrel to provide an outer skin. These films can be polyurethane, Polyester, Polypropylene, Nylon, Polyethelene or other appropriate material. These films can be printed or painted before or after applying them to the object. These films may be applied as tubes or wrapped around the object. In general, depending upon the shape, it may be desirable for the film layer to have heat shrink properties. In this way the film can be shrunk after application to conform directly to the shape of the gel core 20. In general, the outside surface of the pad construction 10 can be further modified to suit the application at hand.

[34] This low durometer gel core 20 and finish layer 24 construction can be configured in any desirable shape to suit impact cushioning condition at hand. For example, the present invention has particular application in cushioning the re-coil of a firearm against the body of a user. The cushioning needs depends on the shooting condition and type, size and

configuration of the firearm being used, as well as the user's preference.

[35] Fig. 3 illustrates the pad construction 100 of the present invention used as an impact re-coil pad for a firearm. Preferably, the pad construction 100 is configured to be similar to the shape of the buttstock 102 of the firearm. The gel core 104 and finish layer 106 pad construction can be simply adhered to the buttstock 102 of a firearm with the pad 104 in direct communication therewith. Alternatively, the pad construction 100 can be mounted to the buttstock 102 by fasteners 108, such as screws or rivets.

[36] However, it is preferred that the re-coil pad, generally referred to as 100, of the present invention be attached to the buttstock 102 of a firearm using the unique attachment construction, which is shown in detail in Fig. 3. A unique mating plate system is employed to connect the re-coil pad 100 to the firearm via buttstock 102. More specifically, an upper plate 110 is bonded to the bottom surface 112 of the pad 100 using a bond promoter 114, such as the fabric layer discussed above. The upper plate 110 can be RF welded to the pad 100 or the gel 104 can be overmolded over the upper plate 110 for good cross-linking. In general, the upper plate 110 is secured to the bottom surface 112 of the pad to provide a first good mating surface.

[37] A complementary lower plate 116 is secured to the buttstock 102 of a firearm itself by fasteners 108, preferably screws. The lower plate 116 secured to the upper surface 118 of the buttstock 102 of a firearm provides a second good mating surface.

[38] Still referring to Fig. 3, a connection structure 120 is provided to mate the upper plate 110, with pad 100 connected thereto, and the lower plate 116, with buttstock 102 connected thereto, together. Adhesive is preferably used for this connection structure 120. As a result, the re-coil pad 100 with finish layer 106 thereon is effectively attached to the buttstock 102 of the firearm.

[39] Preferably, a connection structure 120 can be of many different configurations. For example, complementary hook and loop fasteners may be respectively provided on the plates 110, 116 to serve as the connection structure 120 so the re-coil pad 100 can be removably connected to the buttstock 102 of a firearm. As a result, the re-coil pad 100 can be changed to suit the current shooting conditions or replaced due to wear without damaging the firearm.

[40] Turning now to Fig. 4 a further mounting configuration 200 for the gel re-coil pad of the present invention is shown. In this embodiment, a base member 202 with gel 204 secured thereto with the assistance of a fabric bonding layer 206, is secured directly to a buttstock 208. A finish layer 210

covers the gel layer 204. The buttstock 208 preferably includes a seat 212 to receive the base member 202 of the re-coil pad 200. Cored through holes 214 (one hole is seen in Fig. 4), are provided through the gel 204 so that a fastener 216, such as a screw can be routed therethrough to threadably engage with a female threaded bore 218 in the buttstock 208. The head 216a of the screw 216 secures the base member 202, and the gel 204 thereon, to to the buttstock 208. One or more fasteners 216 can be used to effectively secure the pad 200 to the buttstock as seen in Fig. 4.

[41] In view of the foregoing, a new and unique gel core re-coil pad 10, 100, 200 is provided that is attached to an object to be cushioned, such as a buttstock of a firearm using a novel attachment system.

[42] It would be appreciated by those skilled in the art that various changes and modifications can be made to the illustrated embodiments without departing from the spirit of the present invention. All such modifications and changes are intended to be covered by the appended claims.

WHAT IS CLAIMED IS:

1. A re-coil pad for affixing to the stock of a firearm that collapses and quickly returns to its original shape in response to a re-coil event, comprising:

a solid viscoelastic gel core having a sectional shape appreciably similar to that of the stock; the gel core having a Shore 00 hardness in the range of about 15 to about 45; and

means for attaching the gel core to the stock of a firearm.

2. The re-coil pad according to claim 1, wherein the means for attaching is a pressure sensitive adhesive with a hook and loop closure device for mounting the re-coil pad to the firearm stock.

3. The re-coil pad according to claim 1, wherein the means for attaching is an adhesive.

4. The re-coil pad according to claim 1, wherein the means for attaching is a fastener.

5. The re-coil pad according to claim 4, wherein the fastener is a screw.

6. The re-coil pad according to claim 1, wherein the gel core is made of a natural gel.

7. The re-coil pad according to claim 1, further comprising:

a finish layer on the outer surface of the gel core.

8. The re-coil pad according to claim 1, wherein the finish layer is a coating of polyurethane and silicone polyurea plasticizers in gel.

9. A core construction for a re-coil pad, comprising:
a solid viscoelastic gel having a Shore 00 hardness value in the range of about 15 to about 45 that changes shape and promptly returns to its original shape in response to a re-coil occurrence.

10. The core construction according to claim 9, wherein the gel is a polyurethane gel.

11. A re-coil pad for mounting on the stock of a firearm that changes shape and quickly returns to its original shape in response to a re-coil event, comprising:

a solid polyurethane gel core having a Shore 00 hardness between about 15 and about 45; and

an adjustable hook and loop closure device for affixing to the firearm stock.

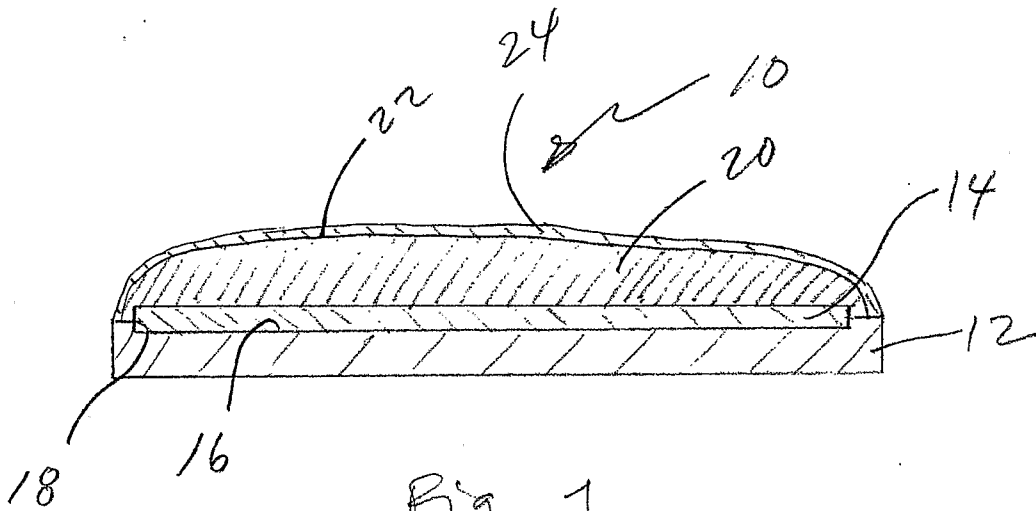

Fig. 1

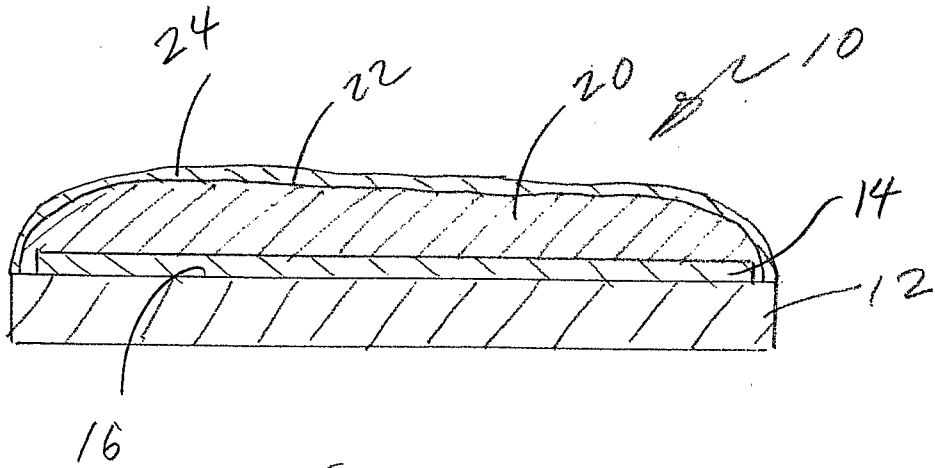

fig. 2

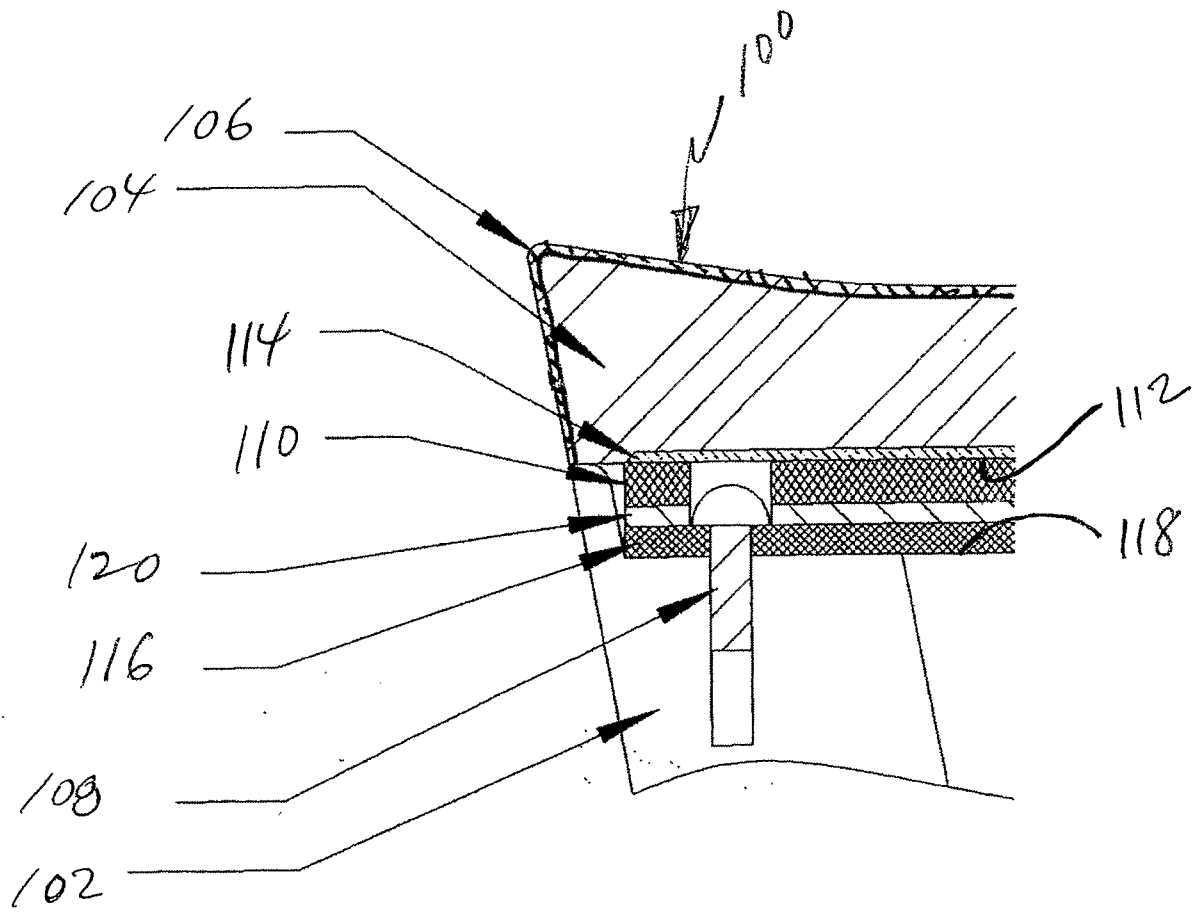

Fig. 3

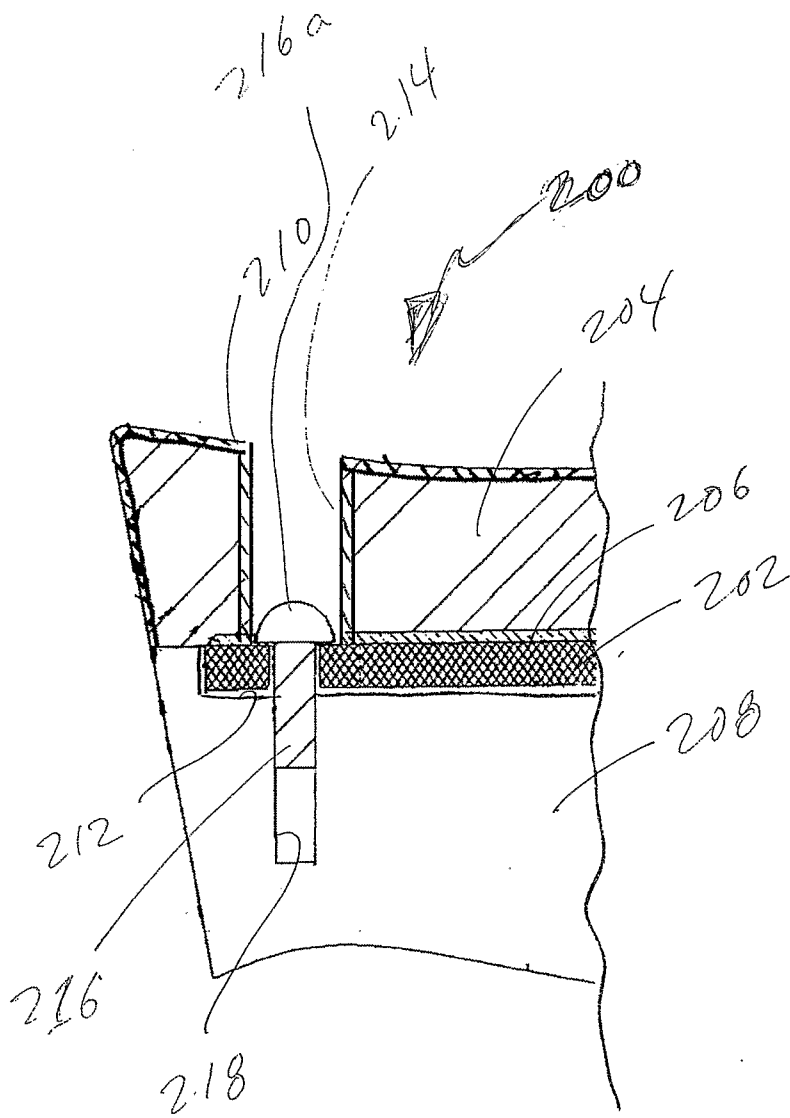

Fig. 4