



(43) International Publication Date
21 December 2023 (21.12.2023)

(51) International Patent Classification:

B65D 51/24 (2006.01) *A47G 19/22* (2006.01)
B65D 47/08 (2006.01) *A45F 3/18* (2006.01)
A47G 19/30 (2006.01)

(21) International Application Number:

PCT/GB2023/051560

(22) International Filing Date:

14 June 2023 (14.06.2023)

(25) Filing Language:

English

(26) Publication Language:

English

(30) Priority Data:

2208725.8 14 June 2022 (14.06.2022) GB
2208833.0 15 June 2022 (15.06.2022) GB

(71) Applicant: **AYDYA LIMITED** [GB/GB]; Gateway West,
5 Luna Place, Dundee Technology Park, Dundee Dumfries
& Galloway DD2 1XF (GB).

(72) Inventor: **OKHAI, Yusuf**; c/o Aydy Limited, Gateway
West, 5 Luna Place, Dundee Technology Park, Dundee
Dumfries & Galloway DD2 1XF (GB).

(74) Agent: **MURGITROYD & COMPANY**; Murgitroyd
House, 165-169 Scotland Street, Glasgow G5 8PL (GB).

(81) Designated States (*unless otherwise indicated, for every kind of national protection available*): AE, AG, AL, AM, AO, AT, AU, AZ, BA, BB, BG, BH, BN, BR, BW, BY, BZ, CA, CH, CL, CN, CO, CR, CU, CV, CZ, DE, DJ, DK, DM, DO, DZ, EC, EE, EG, ES, FI, GB, GD, GE, GH, GM, GT, HN, HR, HU, ID, IL, IN, IQ, IR, IS, IT, JM, JO, JP, KE, KG, KH, KN, KP, KR, KW, KZ, LA, LC, LK, LR, LS, LU, LY, MA, MD, MG, MK, MN, MU, MW, MX, MY, MZ, NA, NG, NI, NO, NZ, OM, PA, PE, PG, PH, PL, PT, QA, RO, RS, RU, RW, SA, SC, SD, SE, SG, SK, SL, ST, SV, SY, TH, TJ, TM, TN, TR, TT, TZ, UA, UG, US, UZ, VC, VN, WS, ZA, ZM, ZW.

(84) Designated States (*unless otherwise indicated, for every kind of regional protection available*): ARIPO (BW, CV, GH, GM, KE, LR, LS, MW, MZ, NA, RW, SC, SD, SL, ST, SZ, TZ, UG, ZM, ZW), Eurasian (AM, AZ, BY, KG, KZ, RU, TJ, TM), European (AL, AT, BE, BG, CH, CY, CZ, DE, DK, EE, ES, FI, FR, GB, GR, HR, HU, IE, IS, IT, LT, LU, LV, MC, ME, MK, MT, NL, NO, PL, PT, RO, RS, SE, SI, SK, SM, TR), OAPI (BF, BJ, CF, CG, CI, CM, GA, GN, GQ, GW, KM, ML, MR, NE, SN, TD, TG).

(54) Title: CAP ASSEMBLY FOR USE WITH A DRINK CONTAINER

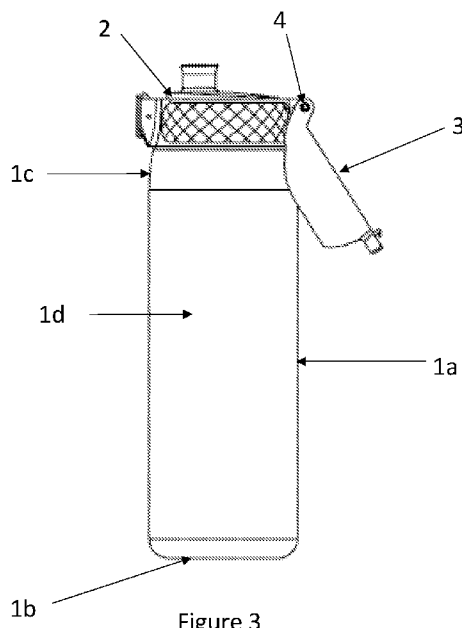

Figure 3

(57) Abstract: The present invention relates to a cap assembly for use with a drink container where the cap assembly is mountable atop the drink container. The cap assembly comprises a base (2) having a fluid outlet (2C), a lid (3), and a pivot hinge (4) comprising a pivot axis configured a spaced distance beyond a perimeter of the base (2) and about which the lid (3) can rotate between a closed lid (3) position and an open lid (3) position. The pivot hinge (4) may comprise a pivot arm (4A) extending from the base (2) and beyond the perimeter of the base (2), and a pivot pin (4B) arranged at a distal end of the pivot arm (4A) and coupled to the lid (3), wherein the pivot pin (4B) defines the pivot axis. The distance between the base (2) and the pivot axis defines the spaced distance. Due to the configuration of the pivot hinge (4), the lid (3) extends from the pivot axis and is arranged below the pivot axis when the lid (3) is arranged in the open lid (3) position. The present invention also relates to a drink system comprising the drink container and the cap assembly.



Published:

- *with international search report (Art. 21(3))*
- *before the expiration of the time limit for amending the claims and to be republished in the event of receipt of amendments (Rule 48.2(h))*

CAP ASSEMBLY FOR USE WITH A DRINK CONTAINER

Field of Invention

5 The present invention relates to a cap assembly for use with a drink container, and a drink system comprising the cap assembly and drink container.

Background to the invention

10 Drink containers are used for storing a drinkable fluid. To help contain spills, a cap assembly is typically mounted on the drink container. The cap assembly includes a fluid outlet (such as a drinking spout or sip hole) from which a user can drink fluid.

15 It has been found that, when a user drinks from the fluid outlet, the configuration of the cap assembly can impair the line of sight of the user. By obstructing the user's vision, the user is at risk. The configuration of the cap assembly can also impair user access to the fluid outlet.

20 The present invention seeks to address at least some of the above problems of the prior art.

Summary of the Invention

25 A first aspect of the present invention relates to a cap assembly for use with a drink container.

In use, the cap assembly is mountable atop an open end of the drink container.

The cap assembly comprises:

30 a base having a fluid outlet;

a lid; and

a pivot hinge interconnecting the base and the lid, the pivot hinge having a pivot axis configured a spaced distance beyond a perimeter of the base, and wherein the lid is rotatably coupled to the pivot hinge to allow the lid to rotate about the pivot axis

35 relative to the base between a closed lid position and an open lid position.

When the lid is in the closed lid position, the fluid outlet is shrouded by the lid to inhibit the dispensing of fluid through the fluid outlet.

5 When the lid is in the open lid position, the fluid outlet is accessible by a user to allow for the dispensing of fluid through the fluid outlet.

10 Configuring the pivot axis the spaced distance beyond the perimeter/periphery/peripheral edge of the base advantageously allows the lid to be rotated around the pivot axis between the closed lid position and the opened lid position without interfering with the base. As such, the lid does not make any restricting contact with the base that may inhibit the rotation of the lid between the closed lid position and the open lid position.

15 Spacing the pivot axis from the base allows the lid to be rotated backwardly relative to the base to the open lid position, whereby the lid extends downwardly from the pivot hinge and the lid is arranged below the pivot axis. As such, the lid is sufficiently located outside a user's line of vision so as not to impair visibility whilst consuming fluid from the fluid outlet. Also, the lid is sufficiently located away from the fluid outlet so as not to impair user access to the fluid outlet. Hence, the arrangement of the lid
20 in the open lid position improves the safety of the user.

25 Spacing the pivot axis from the base allows the lid to be rotated forwardly relative to the base to the closed lid position, whereby the lid is arranged to extend from the pivot hinge across the base, shrouding the fluid outlet and in sealing engagement with the base.

30 In the open lid position, the lid may be configured to extend downwardly below the pivot axis substantially parallel to a side wall of the base and/or a side wall of the drink container. In the open lid position, a portion of the lid may abut the base side wall and/or the drink container side wall, forming a contact engagement. The lid abutting portion may have a corresponding profile to the base side wall and/or the drink container side wall, whereby the lid abutting portion is configured to sit flush with the base side wall and/or the drink container side wall when the lid is in the open lid position.

35

The base may comprise an upper wall in which the fluid outlet is arranged.

5 The pivot axis may be configured below the plane of the base upper wall. As such, the lid is arranged below the plane of the base upper wall when in the open lid position. Hence, the lid is not within the user's line of vision across the base upper wall when in the open lid position.

The pivot hinge may comprise:

10 a pivot arm extending from the base, the pivot arm defining the spaced distance beyond the base; and
a pivot pin arranged at a distal end of the pivot arm, the pivot pin defining the pivot axis, and the lid being rotatably coupled to the pivot pin.

15 The pivot hinge may be a spring loaded pivot hinge. The spring loaded pivot hinge may have an open bias so as to bias the lid away from the closed lid position. The pivot hinge may comprise a biasing spring mounted on the pivot pin, wherein the biasing spring is configured to exert an open biasing force on the lid away from the closed lid position.

20 The cap assembly may comprise a closed lid lock to releasably lock the lid in the closed lid position.

The cap assembly may comprise an open lid lock to releasably lock the lid in the open lid position.

25 The open lid lock may comprise a mating member and a recess configured to form a mating engagement when the lid is in the open lid position, and thereby maintain the lid in the open lid position. The mating member may be resiliently deformable under a user force to locate the mating member in the recess when moving the lid to the open lid position. The mating member may be resiliently deformable under a user force to dislocate the mating member from the recess and thereby allow the lid to move from the open lid position. The mating member may be arranged on the lid, and the recess may be arranged on the pivot hinge.

30

The cap assembly may comprise an intermediate lid lock to releasably lock the lid in an intermediate lid position between the closed lid position and the open lid position.

5 The intermediate lid lock may comprise an abutting member and an abutment configured to form an abutting engagement when the lid is in the intermediate position, and thereby maintain the lid in the intermediate position. The abutting member may be resiliently deformable under a user force to disengage the abutting member from the abutment and thereby allow the lid to move beyond the intermediate lid position to the open lid position or the closed lid position, depending
10 on the rotating direction of the lid about the pivot axis. The abutting member may be arranged on the lid, and the abutment may be arranged on the pivot hinge. The abutment may comprise a protrusion, a ridge or an edge.

The cap assembly may comprise a handle. The handle may be coupled to the pivot
15 hinge and separately rotatable about the pivot axis relative to the lid. The handle may be rotatable to a closed handle position where the user cannot hold the cap assembly via the handle. The handle may be rotatable to an open handle position where the user can hold the cap assembly via the handle. The handle may be rotatable about the pivot axis between a first closed handle position and a second
20 closed handle position, the handle having in an open handle position there between.

In the first closed handle position, the handle may be arranged a first finger access space (distance) from the lid to allow user finger access to the handle. As such, the user can access the handle to move the handle from the first closed handle position.
25 The lid may comprise an inclined surface to form the first finger access space between the handle and the lid.

The lid may comprise a handle recess to receive the handle in the first closed handle position. The handle may be configured to be flush with the lid when it is received in
30 the handle recess in the first closed handle position. The handle recess may comprise the inclined surface to form the first finger access space between the handle recess and the handle when the handle is arranged in the first closed handle position within the handle recess.

In the second closed handle position, the handle may be arranged a second finger access space (distance) from the base to allow user finger access to the handle. As such, the user can access the handle to move the handle from the second closed position.

5

The cap assembly may comprise a first closed handle lock to releasably lock the handle in the first closed handle position.

10

The cap assembly may comprise a second closed handle lock to releasably lock the handle in the second closed handle position.

The cap assembly may comprise an open handle lock to releasably lock the handle in the open handle position.

15

A second aspect of the present invention relates to a drink system comprising:
a drink container having an open end;
a cap assembly mountable atop the open end of the drink container and according to the first aspect of the invention.

20

Brief Description of the Drawings

An embodiment of the present invention will now be described by way of example only and with reference to the accompanying drawings, in which:

25

Figure 1 depicts a perspective view of a first embodiment of a drink system comprising cap assembly mounted atop a drink container, where the cap lid is in the closed lid position and the cap handle is in the first closed handle position;

30

Figure 2 depicts a side view of the drink system of Figure 1, where the cap lid is in the closed lid position and the cap handle is in the first closed handle position;

Figure 3 depicts a side view of the drink system of Figure 1, where the cap lid is in the open lid position and the cap handle is in the first closed handle position;

35

Figure 4 depicts a rear view of the drink system of Figure 1, where the cap lid is in the open lid position and the cap handle is in the first closed handle position;

5 Figures 5, 9 and 14 depict a perspective view of the cap assembly of the drink system of Figure 1, where the cap lid is in the closed lid position and the cap handle is in the first closed handle position;

10 Figures 6 and 13 depict a perspective view of the cap assembly of the drink system of Figure 1, where the cap lid is in the open lid position and the cap handle is in the first closed handle position;

15 Figures 7 and 10 depict a perspective view of the cap assembly of the drink system of Figure 1, where the cap lid is in the intermediate lid position and the cap handle is in the first closed handle position;

Figures 8, 11, 15 depict a cross-sectional view of the cap assembly of the drink system of Figure 1, where the cap lid is in the closed lid position and the cap handle is in the first closed handle position;

20 Figure 12 depicts a cross-sectional view of the cap assembly of the drink system of Figure 1, where the cap lid is in the open lid position and the cap handle is in the first closed handle position;

25 Figures 16 and 17 depict a perspective view of the cap assembly of the drink system of Figure 1, where the cap lid is in the closed lid position and the cap handle is in the open handle position.

30 Figure 18 depicts a cross sectional view of the cap assembly of the drink system of Figure 1, wherein the cap lid is in the closed lid position and the cap handle is in the second closed handle position;

35 Figure 19 depicts a side view of the cap assembly of the drink system of Figure 1, where the cap lid is in the closed lid position and the cap handle is in the second closed handle position;

Figure 20 depicts a perspective view of the cap assembly of the drink system of Figure 1, where the cap lid is in the closed lid position and the cap handle is in the second closed handle position.

- 5 One skilled in the art will readily recognise from the following description that alternative embodiments of the structures illustrated herein may be employed without departing from the principles of the invention described herein and scope of the invention as defined in the claims.

10 Detailed Description of the Invention

Figures 1 to 20 depict an embodiment of a drink system comprising a drink container D and a cap assembly C for use with the drink container D.

- 15 The drink container D is a vessel for storing fluid suitable for consumption ("fluid").

The cap assembly C is mountable atop the drink container D. Together, the drink container D and cap assembly form the drink system. The drink system has a longitudinal axis LL'. When the cap assembly is open, fluid can be dispensed from the drink container through a fluid outlet of the cap assembly. When the cap assembly is closed, fluid is sealed within the drink container.

- In the present invention, the drink container D comprises a body 1 having an open end or mouth. The body comprises an internal cavity in which fluid can be stored.
- 25 Fluid can be added or removed from the internal cavity through the open end. The body may be defined by walls having any suitable construction and material. For example, the walls may have a single or double-walled construction. The walls may have a thermally insulated construction. The drink container may have any suitable configuration. In the embodiment depicted in the Figures (e.g. see Figures 1 to 4),
- 30 the drink container has an open top cylinder configuration. The drink container has a cylindrical shaped body comprising a circular side wall 1a and a flat lower wall 1b. The side wall narrows forming a neck 1c. A top edge of the neck 1c defines the open end (not shown). Fluid can be stored in an internal cavity 1d defined by the walls.

In the present invention and as shown in the Figures, the cap assembly C comprises a base 2 having a fluid outlet, a lid 3 and a pivot hinge 4. The pivot hinge 4 comprises a pivot axis AA' about which the lid 3 can rotate relative to the base 2.

5 As shown in the Figures (e.g. Figures 1 to 4), the cap assembly C is mountable atop the drink container D to cover the open end of the drink container.

The base 2 of the cap assembly C is configured to form a fluid-tight engagement (sealing engagement) with the drink container D and cover the open end. By
10 establishing the sealing engagement, the cap assembly restricts fluid from being dispensed from the drink container other than through the fluid outlet. In the embodiment shown in the Figures, the base 2 may comprise a base seal (not shown) to engage and seal the neck 1c when the base is mounted on the neck 1c to cover the open end of the drink container D.

15

The base 2 of the cap assembly C may have any suitable configuration. The base preferably corresponds to the shape of the drink container D to provide a continuous profile. The base may comprise a side wall and an upper wall. In the embodiment depicted in the Figures, the base has a substantially cylindrical shape corresponding
20 to the cylindrical drink container, and comprises a circular side wall 2a and an upper wall 2b. The perimeter of the base is defined by the circular side wall 2a.

20

The fluid outlet of the cap assembly C allows a fluid to be dispensed from the drink container D through the cap assembly C. The fluid outlet is configured to allow a
25 user to drink fluid directly from the fluid outlet. The fluid outlet may be located on the base upper wall 2b. The fluid outlet may have any suitable configuration. The fluid outlet may comprise an aperture (sip hole) formed in the base upper wall. Alternatively, as in the embodiment depicted in the Figures (e.g. see Figure 6), the fluid outlet may comprise a drinking spout 2c extending from the base upper wall 2b.

25

30 The drinking spout may have a fixed configuration as shown in the Figures. Alternatively, the drinking spout may be movable between a usable position whereby a user can drink from the drinking spout, and an unusable position whereby a user is unable to drink from the drinking spout. For example, the drinking spout may be movable relative to the base upper wall between a usable upright position and an

30

unusable prone position. The base may comprise a drinking spout recess to receive the drinking spout in the unusable prone position.

5 As shown in the Figures (e.g. see Figure 7), the base 2 of the cap assembly C may further comprise an air hole 2d to aid the flow of fluid through the fluid outlet.

10 The base 2 of the cap assembly C may be releasably mountable on the drink container D to allow for the removal and remounting of the cap assembly C on the drink container D. The cap assembly and/or drink container may comprise a releasable attachment to releasably attach the base 2 and the drink container D, forming a releasable sealing engagement. In the embodiment depicted (e.g. see Figure 8), the attachment comprises an internal thread 2e arranged on an inner surface of the base to form a releasable sealing engagement with a corresponding external thread (not shown) arranged on the neck 1c of the drink container.

15 The lid 3 of the cap assembly C is interconnected to the base 2 via the pivot hinge 4. The lid 3 is rotatably coupled to the pivot hinge 4 and is rotatable about the pivot axis AA' relative to the base 2 between a closed lid position and an open lid position relative to the base 2.

20 The lid 3 of the cap assembly C is configured to cover the fluid outlet and close the cap assembly when arranged in the closed lid position. The lid is configured to open the cap assembly and provide user access to the fluid outlet and allow for dispensing of fluid when arranged in the open lid position.

25 The pivot axis AA' of the pivot hinge 4 is arranged at a spaced distance beyond the perimeter/periphery/peripheral edge of the base 2. This spaced arrangement of the pivot axis AA' allows the lid 3 to rotate without interference with the base 2. The lid 3 is rotatable about the pivot axis AA' in a direction towards the fluid outlet (and the base upper wall 2b) to arrange the lid 3 in the closed lid position. Rotation of the lid in the direction towards the fluid outlet may be referred to as rotation in a "forwards direction" about the pivot axis AA'. Due to the pivot AA' being arranged at the spaced distance beyond the perimeter of the base 2, the lid can be rotated forwardly to the closed lid position without interference with the base side wall 2a. The lid 3 is
30 rotatable about the pivot axis AA' in a direction away from the fluid outlet (and the
35

base upper wall 2b) to arrange the lid in the open lid position. Rotation of the lid in the direction away from the fluid outlet may be referred to as rotation in a “backwards direction” about the pivot axis AA'. Due to the pivot axis AA' being arranged at the spaced distance beyond the perimeter of the base 2, the lid can be rotated
5 backwardly to the open lid position without interference with the base upper wall 2b. As such, the lid 3 can be rotated between the closed lid position and the open lid position without interference (restricting contact) with the base 2.

The pivot axis AA' of the pivot hinge 4 may be arranged below the plane of the base upper wall. For example, in the embodiment shown in the Figures, the pivot axis AA'
10 of the pivot hinge 4 is arranged below the plane of base upper wall 2b.

The pivot hinge 4 of the cap assembly C may have any suitable pivot configuration. The pivot hinge 4 may comprise a pivot pin to define the pivot axis AA', whereby the
15 lid is rotatably coupled to the pivot pin to allow for the rotation of the lid 3 about the pivot axis AA' relative to the base 2. The pivot pin may be rotatable or fixed.

The pivot hinge 4 of the cap assembly C may comprise a pivot arm extending from the base where the pivot pin is arranged at a distal end of the pivot arm. Due to the
20 configuration of the pivot arm extending from the base, the pivot axis is arranged a spaced distance beyond the periphery of the base. The distance along the pivot arm between the base and the pivot axis AA' defines the spaced distance. In the embodiment shown in the Figures, the pivot hinge comprises a pivot arm 4a extending from the base side wall 2a, and a pivot pin 4b arranged at a distal end of
25 the pivot arm. The pivot pin 4b extends through a pivot hole formed in the distal end of the pivot arm. A first end of the pivot pin protrudes from one end of the pivot hole, and a second end of the pivot pin protrudes from the other, opposing, end of the pivot hole. The pivot pin 4b defines the pivot axis AA' and is rotatable within the pivot hole. As shown in the Figures, the pivot arm 4a extends generally perpendicularly
30 from the base side wall 2a. The pivot arm 4a arranges the pivot pin 4b (defining the pivot axis AA') a spaced distance from the base side wall 2a, and thereby beyond the perimeter of the base 2. An upper surface of the pivot arm 4a is generally flush with the base upper wall 2b. As such, the pivot pin 4b in the pivot hole, and thereby the pivot axis AA', are arranged below the plane of the base upper wall 2b.

35

The pivot hinge 4 of the cap assembly C may be a spring loaded pivot hinge. The spring loaded pivot hinge may have an open bias so as to bias the lid away from the closed lid position or a closed bias so as to bias the lid away from the open lid position. The pivot hinge may comprise a biasing spring mounted on the pivot pin, wherein the biasing spring is configured to exert a biasing force on the lid. For example, in the embodiment shown (e.g. see Figure 8), the pivot hinge 4 comprises a biasing spring 4c mounted on the pivot pin 4b to exert a biasing force on the lid 3 away from the closed lid position.

The lid 3 of the cap assembly C may have any suitable shape. The lid shape preferably corresponds to the shape of the base 2. The lid 3 may comprise at least one arm to connect with the pivot hinge 4. The lid may comprise a side wall and an upper wall. In the embodiment depicted in the Figures, the lid comprises a side wall 3a and a sloping upper wall 3b. The lid also comprises a pair of parallel arms, first lid arm 3e and second lid arm 3f. The first lid arm 3e is coupled to the first end of the pivot pin 4b and the second lid arm 3f is coupled to the second end of the pivot pin 4b.

When the lid 3 of the cap assembly C is arranged in the closed lid position, the lid 3 extends from the pivot axis AA' across the base 2. The lid 3 shrouds the drinking outlet and engages with the base, thereby closing the cap assembly C. The lid 3 preferably forms a fluid-tight engagement (sealing engagement) with the base 2 and/or the fluid outlet 2c to prohibit the leakage of fluid from the closed cap assembly. Due to the spaced distance of the pivot AA' from the perimeter of the base, the lid extends from the pivot axis AA' and across the base without interference with the base. In the embodiment shown in the Figures (e.g. see Figures 1, 2, 5, 8 and 9), the lid 3 extends from the pivot axis AA' across the base upper wall 2b. The lid upper wall 3b covers the drinking spout 2c. A lower edge (rim) of the lid side wall 3a abuts the base upper wall 2b, forming a contact engagement. Since the pivot axis AA' is arranged below the plane of the base upper wall 2b the lid 3 is thereby arranged substantially above the pivot axis AA' when in the closed lid position.

The lid 3 of the cap assembly C may comprise a lid seal to form a sealing engagement with the base 2 when the lid is arranged in the closed lid position. As

shown (e.g. in Figures 6 and 7), the lid 3 may comprise a drinking spout seal 3c and/or an air hole seal 3d to engage and seal the corresponding drinking spout 2c and/or air hole 2d when the lid is arranged in the closed lid position.

5 The cap assembly C may comprise a closed lid lock to releasably maintain the lid 3 in the closed lid position relative to the base 2, and thereby maintain closure of the cap assembly (maintain the sealing engagement between the lid and the base). The closed lid lock may be any suitable locking means. The closed lid lock may be user
10 activated and/or automatically activated. In the embodiment depicted in the Figures (e.g. see Figure 7), the cap assembly comprises a closed lid lock 5 having a fastener 5a to receive and hold a corresponding catch 3h of the lid in the closed lid position relative to the base. The fastener 5a is mounted on the base side wall 2a and the catch 3h is mounted on the lid side wall 3a. When the closing of the cap assembly C is desired, the lid 3 is rotated forwardly about the pivot axis AA' of the pivot hinge 4
15 towards the closed lid position and the fastener 5a is activated to engage the catch 3h to hold the lid 3 in the closed lid position in sealing engagement with the base 2. In this embodiment, the fastener 5a is automatically activated to engage the catch 3h as the lid is located in the closed lid position. When the opening of the cap assembly is desired, a user can activate the fastener 5a to release the catch 3h, and thereby
20 allow for the lid to be rotated backwardly about the pivot axis AA' of the pivot hinge 4 towards the open lid position.

When arranged in the open lid position, the lid 3 extends backwardly and away from the pivot axis AA' of the pivot hinge 4 in a direction below the pivot axis AA'. As such,
25 the lid is arranged at least substantially below the pivot axis AA'. Extending away from the pivot axis AA' in a direction below the pivot axis AA' may be referred to as extending in a "downwardly" direction. Due to the spaced distance of the pivot axis AA' from the perimeter of the base 2, the lid 3 extends downwardly below the pivot axis AA' without interference with the base upper wall 2b. See, for example, Figures
30 3, 4, 6, 12 and 13.

As in the embodiment shown in the Figures, where the pivot axis AA' of the pivot hinge 4 may be arranged below the plane of the base upper wall 2b, the lid 3 is thereby arranged below the plane of the base upper wall when in the open lid
35 position.

When the lid 3 is in the open lid position, the cap assembly C is open and the fluid outlet is accessible to the user to allow the user to drink from the drinking container D via the cap assembly C.

5 Due to the configuration of the lid 3 in the open lid position, the user is able to consume fluid from the fluid outlet with minimal interference between the user and the lid 3, and with minimal visibility of the lid 3. As such, the lid 3 in the open lid position does not impair the user's access to the fluid outlet or impair the user's visibility when consuming fluid from the fluid outlet.

10

In the open lid position, the lid 3 may extend in a direction generally parallel to the base side wall 2a and/or the drink container side wall 1a. As in the embodiment shown (e.g. see Figures 3 and 12), a portion 3g of the lid upper wall 3b may abut the base side wall 2a and/or the drink container side wall 1a when the lid is arranged in the open lid position. As such, the lid abutting portion 3g forms a contact engagement with the base side wall 2a and/or the drink container side wall 1a. As depicted in the Figures, the lid abutting portion 3g may have a concave profile that is configured to correspond to the circular profile of the base side wall 2a and/or the drink container side wall 1a to allow the lid to sit flush against the base 2 and/or the drink container D when in the open lid position.

15

20

The cap assembly C may comprise an open lid lock to releasably maintain the lid 3 in the open lid position relative to the base 2, and thereby maintain the opening of the cap assembly C. The open lid lock may be any suitable locking means. The open lid lock may be user activated and/or automatically activated. The open lid lock may comprise a mating member and a recess configured to receive and form a mating engagement with the corresponding mating member. The mating member may be resiliently deformable under a user force to engage and/or disengage with the recess. The mating member may comprise any suitable resiliently deformable material, including plastic or rubber. The mating member and recess may comprise any suitable configuration. The mating member may be arranged on the lid 3, and the recess may be arranged on the pivot hinge 4. In the embodiment depicted (e.g. see Figures 6, 9, 12 and 13, the mating member of the open lid lock comprises a pair of parallel mating protrusions, a first protrusion 6a and a second protrusion 6b, extending from the lid. As shown in the Figures, the first protrusion 6a and second

25

30

35

protrusion 6b extend outwardly from the lid 3 in a gap space between the first lid arm 3e and second lid arm 3f. The protrusions are formed from a resiliently deformable plastic and are resiliently deformable under a user force. The recess of the open lid lock comprises an indent 6c arranged on the pivot hinge 4, and configured to receive the first protrusion 6a and second protrusion 6b. In this embodiment, the indent 6c is an underside recessed portion of the pivot arm 4a between the base side wall 2a and a bullnose abutment 7a at the distal end of the pivot arm 4a. The indent 6c extends the width of the pivot arm 4a. When opening the cap assembly C is desired, the lid 3 is rotated backwardly about the pivot axis AA' of the pivot hinge 4 towards the open lid position, whereby when the lid 3 is in the open lid position the protrusions 6a, 6b extend in a direction towards the underside of the pivot arm 4a. As such, the indent 6c receives and forms a mating engagement with the protrusions 6a, 6b to hold the lid 3 in the open lid position. When the closing of the cap assembly is desired, a user can apply a force to resiliently deform and disengage the protrusions 6a, 6b from the indent 6c, and thereby allow for the lid 3 to be rotated forwardly about the pivot axis AA' of the pivot hinge 4 towards the closed lid position.

The cap assembly C may further comprise an intermediate lid lock to releasably lock the lid 3 in an intermediate lid position between the closed lid position and the open lid position. The intermediate lid lock may lock the lid in the intermediate position as the lid 3 is rotated between the closed lid position and the open lid position. The intermediate lid lock may lock the lid 3 in the intermediate position as the lid is rotated backwardly about the pivot axis AA' of the pivot hinge 4 from the closed lid position towards the open lid position. The intermediate lock may lock the lid 3 in the intermediate position as the lid is rotated forwardly about the pivot axis AA' of the pivot hinge 4 from the open lid position towards the closed lid position. The intermediate lid lock may be user activated and/or automatically activated.

When arranged in the intermediate lid position, the lid 3 extends backwardly and away from the pivot axis AA' in an outwardly direction away from the pivot hinge 4 and the base 2. Due to the spaced distance of the pivot axis AA' from the perimeter of the base, the lid 3 extends outwardly from the pivot axis AA' in a direction away from the base without interference with the base. As shown in the embodiment depicted in the Figures (e.g. see Figures 7 and 10), the lid 3 may extend away from

the pivot axis AA' in a direction generally parallel with the pivot arm 4a and generally perpendicular to the base side wall 2a when in the intermediate lid position.

The intermediate lid lock may be any suitable locking means. The intermediate lid lock may comprise an abutting member and an abutment configured to form an abutting engagement when the lid 3 is in the intermediate position, and thereby maintain the lid 3 in the intermediate lid position. The abutting member may be resiliently deformable under a user force to disengage the abutting member from the abutment and thereby allow the lid 3 to move beyond the intermediate lid position to the open lid position or the closed lid position, depending on the rotating direction of the lid about the pivot axis AA' of the pivot hinge 4. The abutting member may comprise any suitable resiliently deformable material, including plastic or rubber. The abutting member and abutment may have any suitable configuration. The abutting member may be arranged on the lid 3, and the abutment may be arranged on the pivot hinge 4. The mating member of the open lid lock and the abutting member of the intermediate lid lock may be the same or different components. The abutment may comprise a protrusion, a ridge or an edge formed on the pivot hinge 4. In the embodiment depicted (e.g. see Figures 7, 10 and 11) the first protrusion 6a and the second protrusion 6b extending from the lid in the gap space between the first lid arm 3e and second lid arm 3f also act as abutting members for the intermediate lid lock. The abutment of the intermediate lid lock comprises the bullnose 7a formed at the distal end of the pivot arm 4a. The bullnose 7a has a curved or teardrop shape, and it extends from the underside of the distal end of the pivot arm 4a. The bullnose 7a extends the width of the pivot arm 4a. As the lid 3 is rotated about the pivot axis AA', the protrusions 6a, 6b will abut the bullnose 7a and form an abutting engagement thereby stopping any further rotation of the lid and holding the lid 3 in the intermediate lid position. The protrusions 6a, 6b may be configured to slide across the pivot arm surface as the lid rotates about the pivot axis AA' until the protrusion 6a, 6b abuts the bullnose 7a. The protrusions 6a, 6b and bullnose 7a are configured to abut to hold the lid in the intermediate lid position as the lid is rotated backwardly about the pivot axis AA' from the closed lid position towards the open lid position. Likewise, the protrusions 6a, 6b and bullnose 7a are configured to abut to hold the lid in the intermediate lid position as the lid is rotated forwardly about the pivot axis AA' from the open lid position towards the closed lid position. To release the lid from the intermediate lid position, a user can apply a force to resiliently deform

the protrusions 6a, 6b and push them beyond the bullnose 7a. Once released, the lid can then continue to be rotated about the pivot axis AA' to the open lid position or the closed lid position as desired.

5 To further assist the user, the cap assembly C may comprise a handle. The handle may be coupled to the pivot hinge 4 and separately rotatable about the pivot axis AA' relative to the lid 3 to allow the handle to rotate relative to the lid. The lid is rotatable to a closed handle position, where the handle is unusable by the user to hold the cap assembly. The lid is rotatable to an open handle position where the handle is usable
10 by the user to hold the cap assembly.

As in the embodiment shown (e.g. see Figures 14 to 20), the cap assembly C may comprise a handle 8 having an aperture 8a through which a user can extend one or more finger. The handle 8 is rotatably coupled to the pivot hinge 4 to rotate about the
15 pivot axis AA'. The handle 8 is separately rotatable about the pivot axis AA' relative to the lid 3. The handle may comprise a pair of parallel arms, a first handle arm 8b and a second handle arm 8c. The first handle arm 8b is coupled to the first end of the pivot pin 4b and the second handle arm 8c is coupled to the second end of the pivot pin 4b. The handle 8 is rotatable about the pivot axis AA' in a forwards direction
20 towards the lid 3 and in a backwards directions away from the lid. As in the embodiment shown, the handle 8 may be rotatable between a first closed handle position and a second closed handle position. The handle may be rotatable to an open handle position there between the first closed handle position and the second closed handle position.

25 When the handle 8 is arranged in the first closed handle position, the handle may extend from the pivot axis AA' across the lid. See Figures 14 and 15.

As in the embodiment shown in the Figures, the lid 3 may comprise a handle recess
30 9 in which to receive the handle 8 when arranged in the first closed handle position. The handle recess 9 is configured so that the handle can sit flush within the recess when the handle is arranged in the first closed handle position. In the embodiment shown, the recess is formed in the lid abutting portion 3g with the concave profile. The handle 8 has a corresponding concave profile such that when the handle is

arranged in the first closed handle position, the lid abutting portion 3g and the closed handle form a homologous concave surface.

5 The lid 3 may comprise a first finger access space to provide a finger sized gap space between the lid and the handle when arranged in the first closed handle position. The first finger access space allows the user to access and lift the handle to rotate it away from the lid. A wall of the handle recess 9 may be indented to form the first finger access space, for example a side wall of the recess. A wall of the handle recess 9 may be inclined to form the first finger access space between the lid and
10 the handle. In the embodiment depicted (e.g. see Figure 10), the rear wall 9a of the handle recess is inclined such that a first finger access space 10 is formed between the lid 3 and the handle 8 when the handle is arranged in the first closed handle position within the handle recess 9. As such, the user can extend one or more finger through the handle aperture 8a and under the handle 8 to raise and rotate the handle
15 from the first closed handle position when desired.

When the handle 8 is arranged in the open handle position, the handle 8 extends outwardly from the pivot axis AA' in a direction away from the lid 3 and the base 2. In the embodiment shown, the handle extends from the pivot axis AA' in an upwardly
20 direction away from the lid. The handle 8 may be rotated about the pivot axis AA' to the open handle position from the first closed handle position or the second closed handle position as desired. A user can extend one or more finger through the aperture 8a to hold the cap assembly. See Figures 16 and 17.

25 When the handle 8 is arranged in the second closed handle position, the handle 8 may extend backwardly and away from the pivot axis AA' in a direction below the pivot axis AA'. In the second closed handle position, the handle 8 may extend in a generally parallel direction to the base side wall 2a. As in the embodiment shown in Figures 18 to 20, the handle may abut the base side wall 2a, forming a contact
30 engagement, when arranged in the second closed handle position. A second finger access space may be formed between the handle 8 and the base 2, when the handle is in the second closed handle position, to allow use access to the handle. In the embodiment as shown, the second finger access space may be formed due to the concave profile of the handle 8.

35

The cap assembly C may comprise a closed handle lock to releasably lock the handle 8 in the closed handle position. The closed handle lock may have any suitable configuration. As in the embodiment shown in the Figures, the cap assembly C may comprise a first closed handle lock to releasably lock the handle in the first closed handle position. In the embodiment depicted (e.g. see Figure 17), the first closed handle lock comprises a protrusion 11 formed in the recess 9 to form an abutting engagement with the handle 8 when the handle is located in the first closed lid position within the recess 9. The cap assembly may comprise a second closed handle lock to releasably lock the handle in the second closed handle position.

The cap assembly C may comprise an open handle lock to releasably lock the handle 8 in the open handle position. The open handle lock may have any suitable configuration. In the embodiment shown (e.g. see Figure 17), the open handle lock comprises a protrusion 12 arranged on an outside surface of one or more of the handle arms 8b, 8c to form an abutting engagement with the corresponding adjacent lid arm 3e, 3f.

Although the invention has been described above with reference to a preferred embodiment, it will be appreciated that various changes or modifications may be made without departing from the scope of the invention as defined in the defined claims.

Optional features described in relation to the invention can be combined. Any subject matter described in this specification can be combined with any other subject matter in the specification to form any combination.

The embodiment described herein should be understood to have broad application, and is meant to illustrate one possible way of carrying out the invention, without intending to suggest that the scope of this disclosure, including the claims, is limited to that embodiment. Furthermore, the terminology and phraseology used herein is solely used for descriptive purposes and should not be construed as limiting in scope.

All singular forms of elements, or any other components described herein are understood to include plural forms thereof and vice versa. Language such as "including", "comprising", "having", "containing", or "involving" and variations thereof, is intended to be broad and encompass the subject matter listed
5 thereafter, equivalents, and additional subject matter not recited, and is not intended to exclude other additives, components, integers or steps. Likewise, the term "comprising" is considered synonymous with the terms "including" or "containing" for applicable legal purposes. Thus, throughout the specification and claims unless the context requires otherwise, the word "comprise" or
10 variations thereof such as "comprises" or "comprising" will be understood to imply the inclusion of a stated integer or group of integers but not the exclusion of any other integer or group of integers. Any discussion of documents, acts, materials, devices, articles and the like is included in the specification solely for the purpose of providing a context for the present invention. It is not suggested or
15 represented that any or all of these matters formed part of the prior art base or were common general knowledge in the field relevant to the present invention. In this disclosure, whenever a composition, an element or a group of elements is preceded with the transitional phrase "comprising", it is understood that we also contemplate the same composition, element or group of elements with
20 transitional phrases "consisting essentially of", "consisting", "selected from the group of consisting of", "including", or "is" preceding the recitation of the composition, element or group of elements and vice versa. In this disclosure, the words "typically" or "optionally" are to be understood as being intended to indicate optional or non-essential features of the invention which are present in
25 certain examples but which can be omitted in others without departing from the scope of the invention.

References to directional and positional descriptions such as upper and lower and directions e.g. "forwardly", "backwardly", "downwardly" etc. are to be
30 interpreted by a skilled reader in the context of the examples described to refer to the orientation of features shown in the drawings, and are not to be interpreted as limiting the invention to the literal interpretation of the term, but instead should be as understood by the skilled addressee.

CLAIMS

1. A cap assembly usable with a drinking container, wherein the cap assembly is mountable atop the drinking container, the cap assembly comprising:
 - 5 a base having a fluid outlet;
 - a lid;
 - a pivot hinge interconnecting the base and lid, the pivot hinge having a pivot axis configured a spaced distance from a perimeter of the base;
 - wherein the lid is rotatably coupled to the pivot hinge to allow the lid to rotate
10 about the pivot axis relative to the base between a closed lid position and an open lid position without interference with the base; and
 - whereby in the open lid position, the lid is configured to extend from the pivot hinge and is arranged below the pivot axis.
- 15 2. The cap assembly of claim 1, wherein the fluid outlet is arranged in a base upper wall;
 - wherein the pivot axis is configured below the plane of the base upper wall;
 - and
 - whereby in the open lid position, the lid is configured below the plane of the
20 base upper wall.
3. The cap assembly of any preceding claim, wherein the lid comprises a lid abutting portion configured to form a contact engagement with a base side wall when the lid is in the open position.
25
4. The cap assembly of claim 3, wherein the lid abutting portion has a corresponding profile to the base side wall, whereby the lid abutting portion is flush with the base side wall when the lid is in the open position.
- 30 5. The cap assembly of any preceding claim, wherein the pivot hinge comprises:
 - a pivot arm extending from the base, the pivot arm defining the spaced distance beyond the base;
 - a pivot pin arranged at a distal end of the pivot arm, the pivot pin defining the pivot axis, and the pivot pin being rotatably coupled to the lid.

35

6. The cap assembly of any preceding claim, wherein the pivot hinge is a spring loaded pivot hinge with an open bias.
- 5 7. The cap assembly of any preceding claim, further comprising a closed lid lock to releasably lock the lid in the closed lid position.
8. The cap assembly of any preceding claim, further comprising an open lid lock to releasably lock the lid in the open lid position.
- 10 9. The cap assembly of claim 8, wherein the open lid lock comprises a mating member and a recess configured to form a mating engagement when the lid is in the open lid position.
- 15 10. The cap assembly of claim 9, wherein the mating member is resiliently deformable under a user force to locate the mating member in the recess when moving the lid to the open lid position and/or the mating member is resiliently deformable under a user force to dislocate the mating member from the recess when moving the lid from the open lid position.
- 20 11. The cap assembly of any preceding claim, further comprising an intermediate lid lock to releasably lock the lid in an intermediate lid position between the closed lid position and the open lid position.
- 25 12. The cap assembly of claim 11, wherein the intermediate lid lock comprises an abutting member and an abutment configured to form an abutting engagement when the lid is in an intermediate position.
- 30 13. The cap assembly of claim 12, wherein the abutting member is resiliently deformable under user force to disengage the abutting member from the abutment when moving the lid from the intermediate lid position.
- 35 14. The cap assembly of any preceding claim, further comprising a handle rotatably coupled to the pivot hinge to rotate about the pivot axis relative to the lid between a first closed handle position and a second closed handle position, the handle having an open handle position there between.

15. The cap assembly of claim 14, whereby the lid comprises a handle recess configured to receive the handle in the first closed handle position.
- 5 16. The cap assembly of claim 15, wherein the handle recess comprises an inclined surface to form a first finger access space between the handle recess and handle when the handle is in the first closed handle position within the handle recess.
- 10 17. The cap assembly of any of claims 14 to 16, comprises a second finger access space between the base and the handle when the handle is in the second closed handle position.
- 15 18. The cap assembly of any of claims 14 to 17, further comprising a first closed handle lock to releasably lock the handle in the first closed handle position.
- 20 19. The cap assembly of any of claims 14 to 18, further comprising a second closed handle lock to releasably lock the handle in the second closed handle position.
- 20 20. A drink system comprising:
a drink container comprising:
an open end;
a cap assembly comprising:
a base mountable on the drink container to cover the open end, the base comprising a fluid outlet;
25 a lid; and
a pivot hinge interconnecting the base and the lid, the pivot hinge having a pivot axis configured a spaced distance beyond a perimeter of the base;
wherein the lid is rotatably coupled to the pivot hinge to allow the lid to rotate about the pivot axis relative to the base between a closed lid position and an
30 open lid position without interference with the base; and
whereby in the open lid position, the lid is configured to extend from the pivot hinge and is arranged below the pivot axis.
- 35 21. The drink system of claim 20, wherein the cap assembly comprises the features as defined in any of claims 2 to 19.

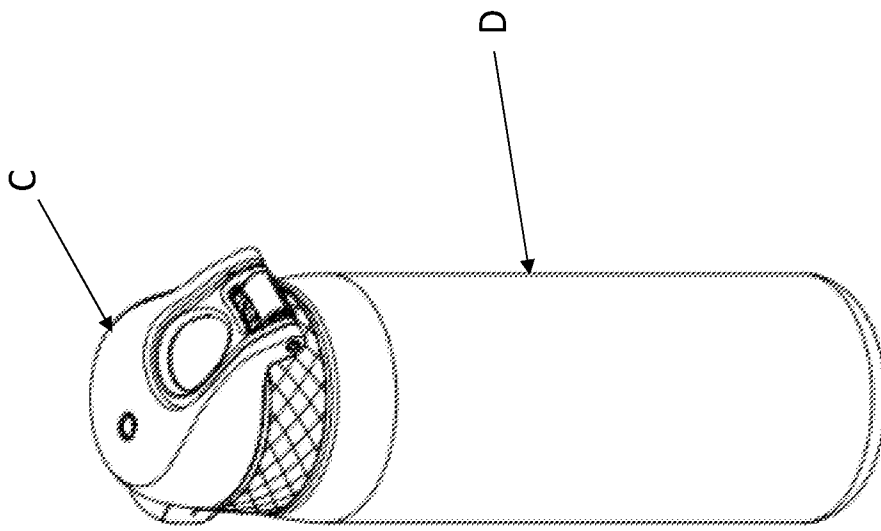

Figure 1

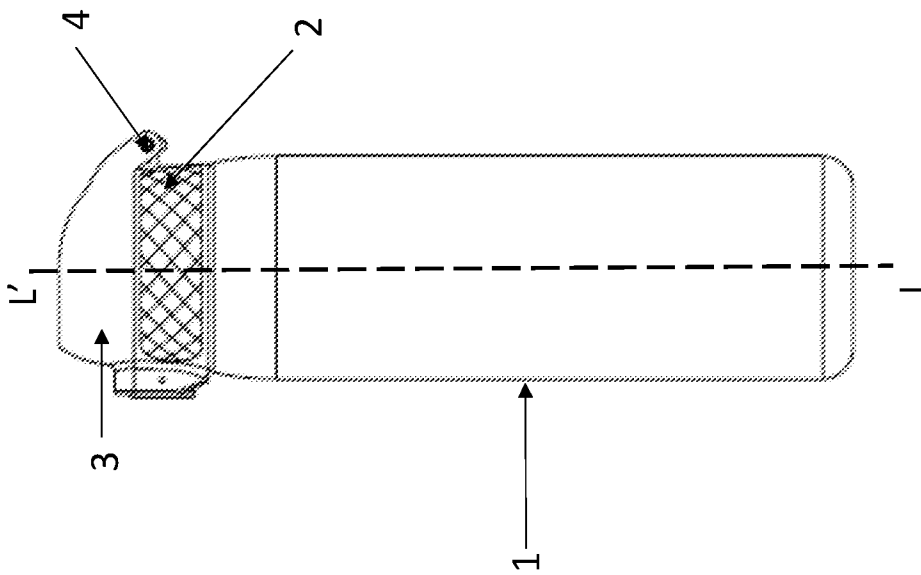
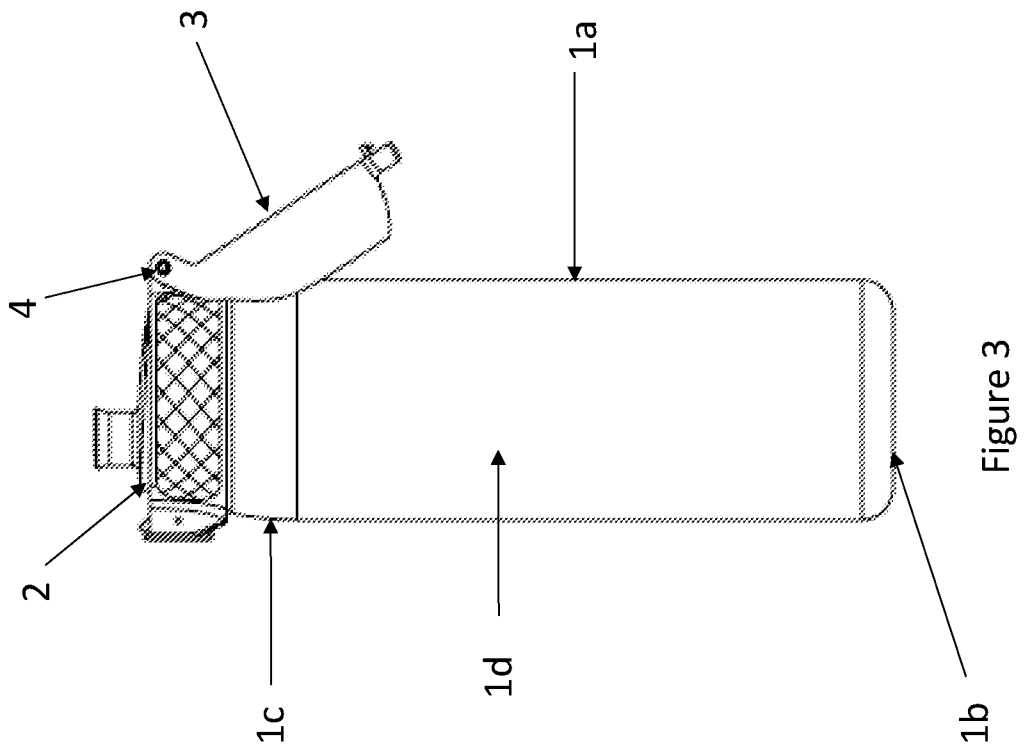

Figure 2



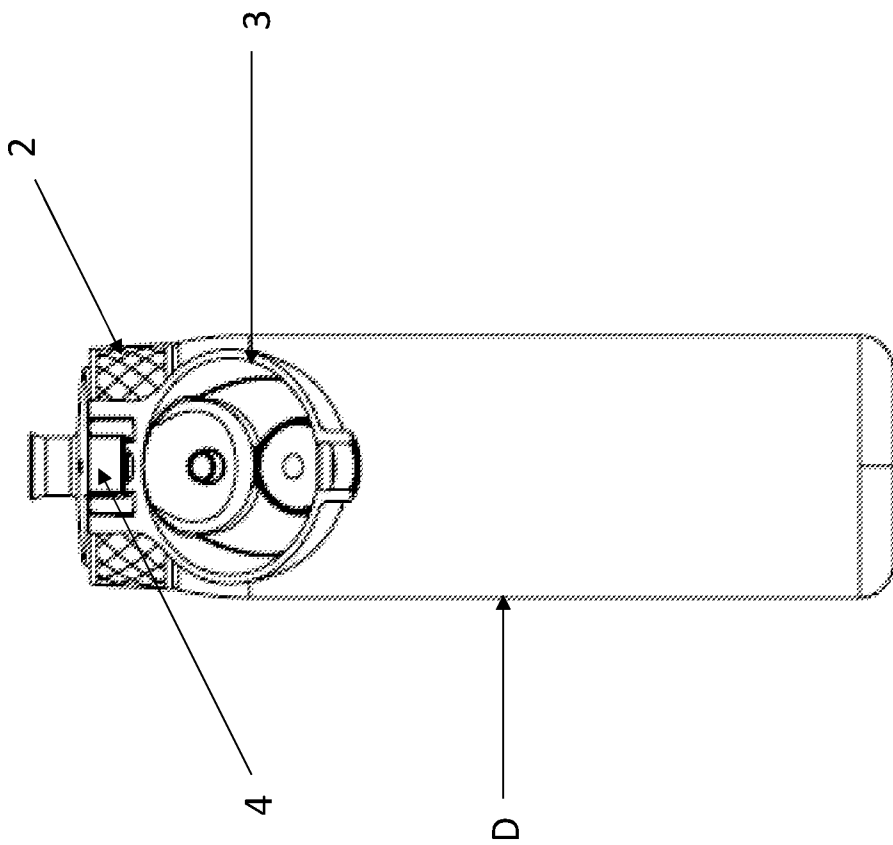

Figure 4

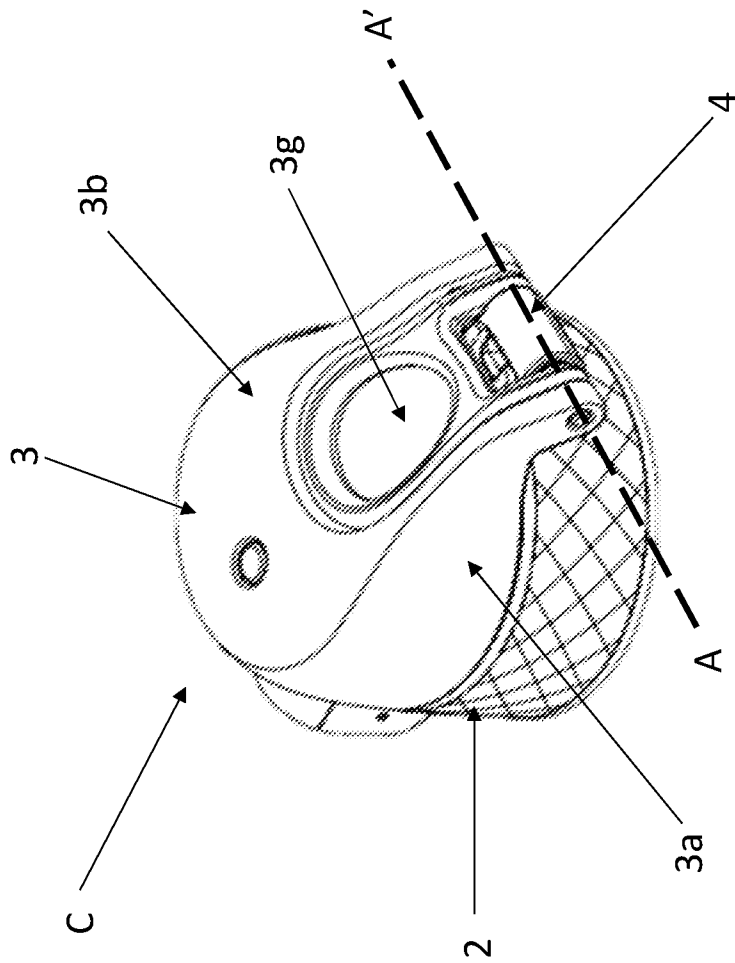

Figure 5

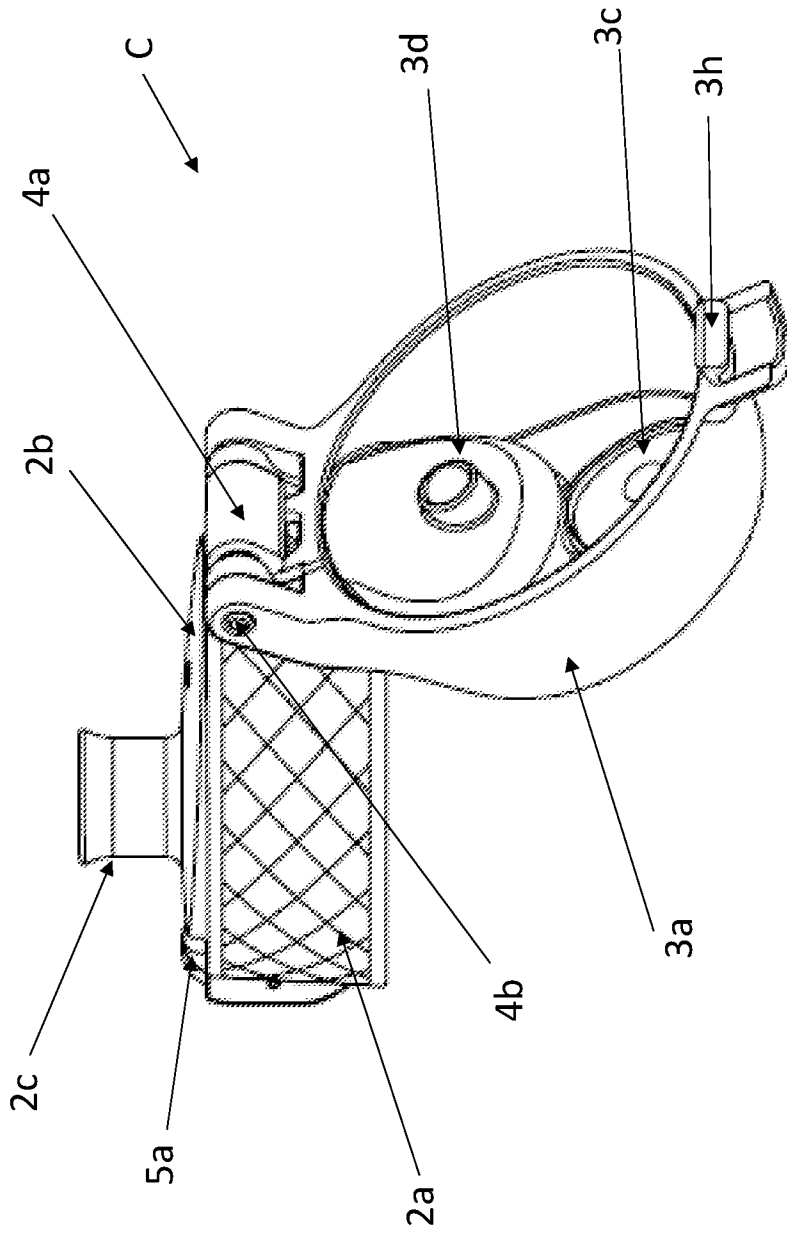

Figure 6

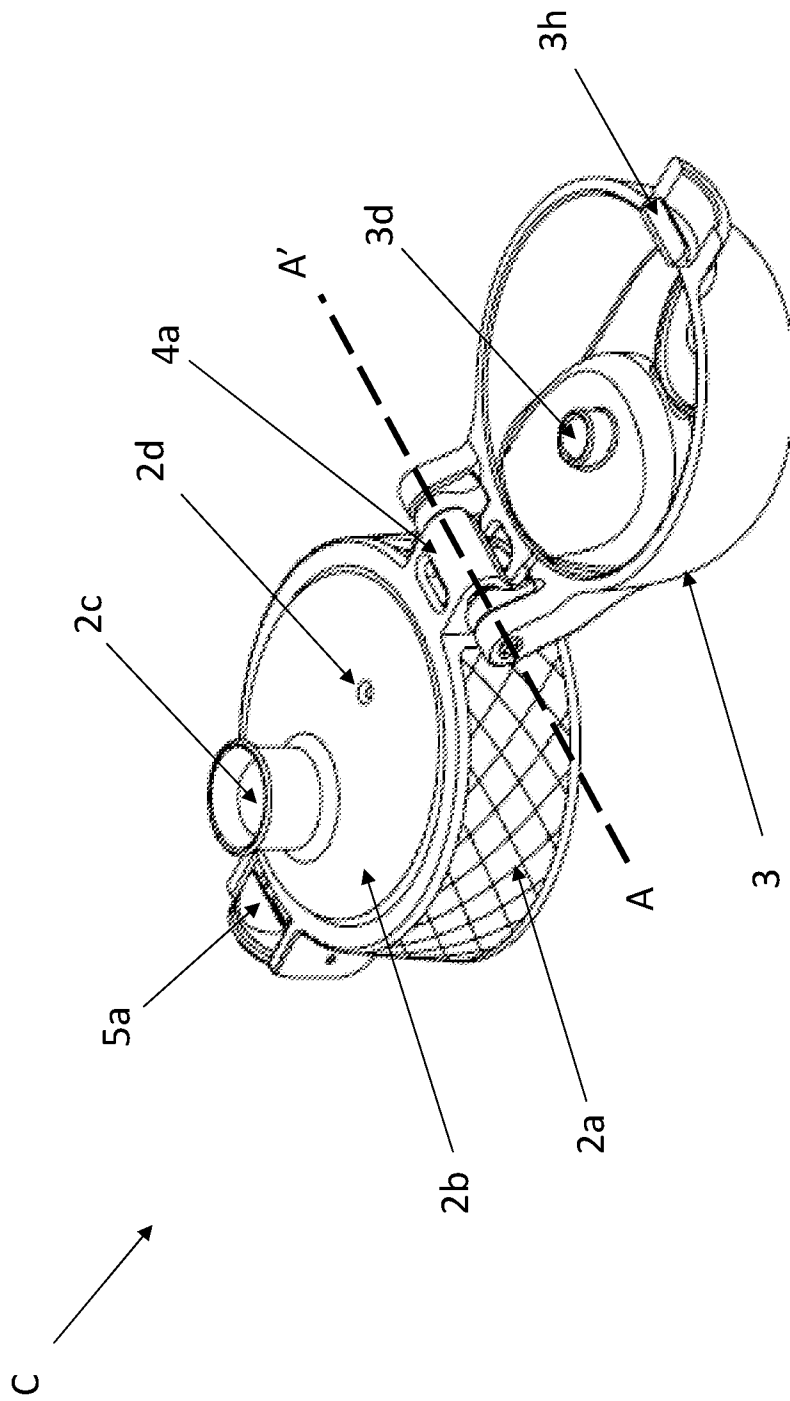

Figure 7

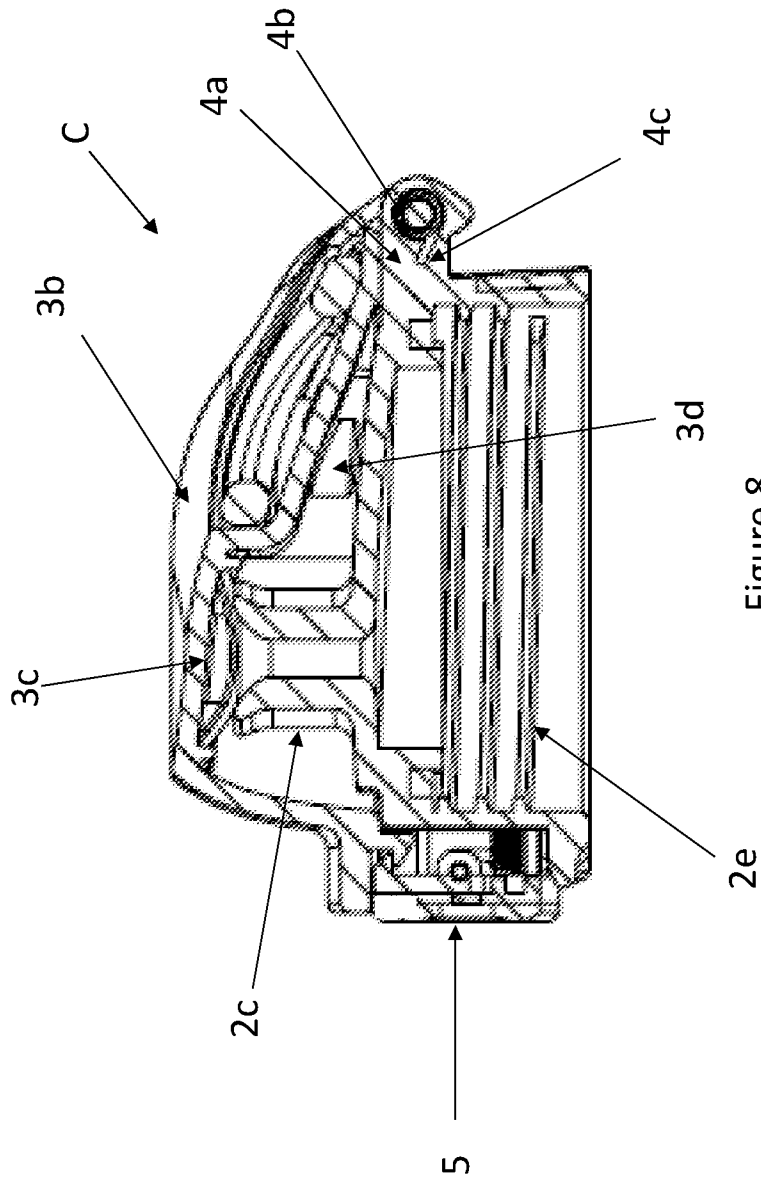

Figure 8

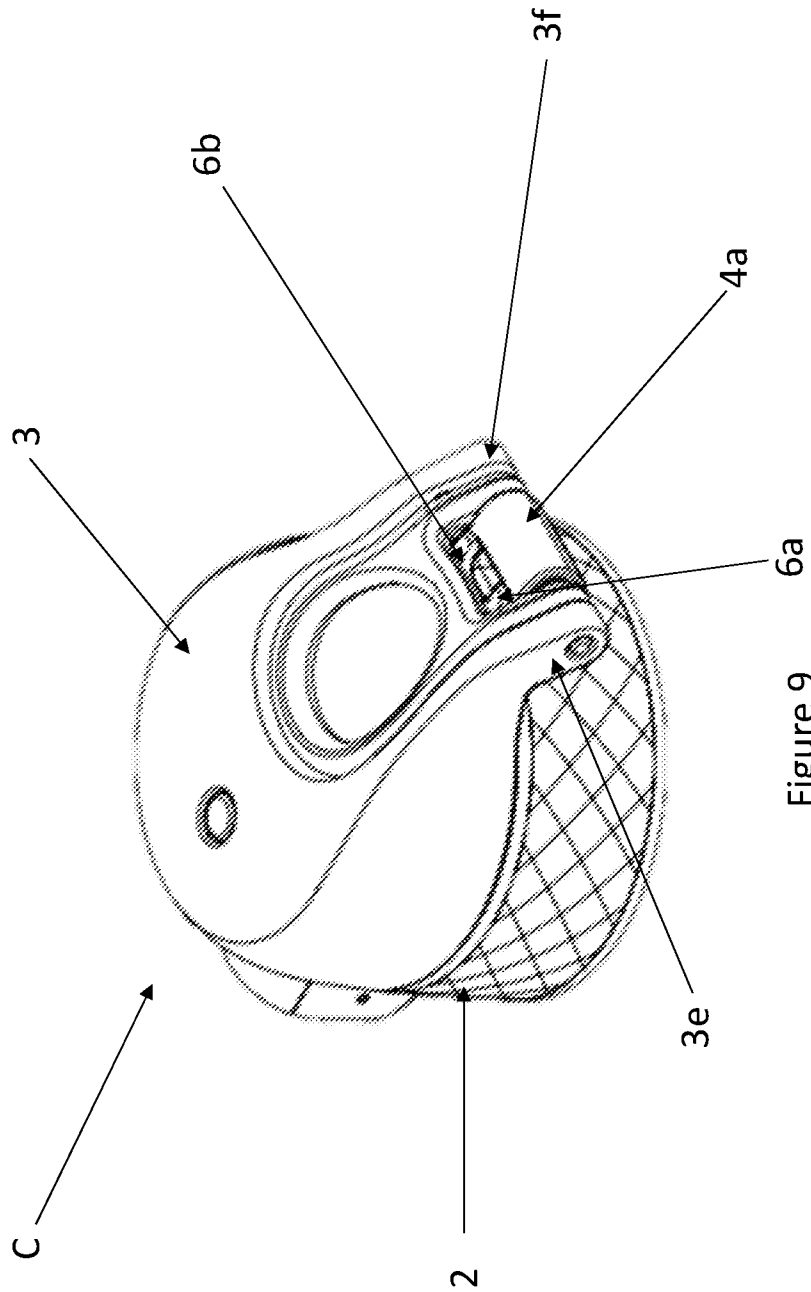

Figure 9

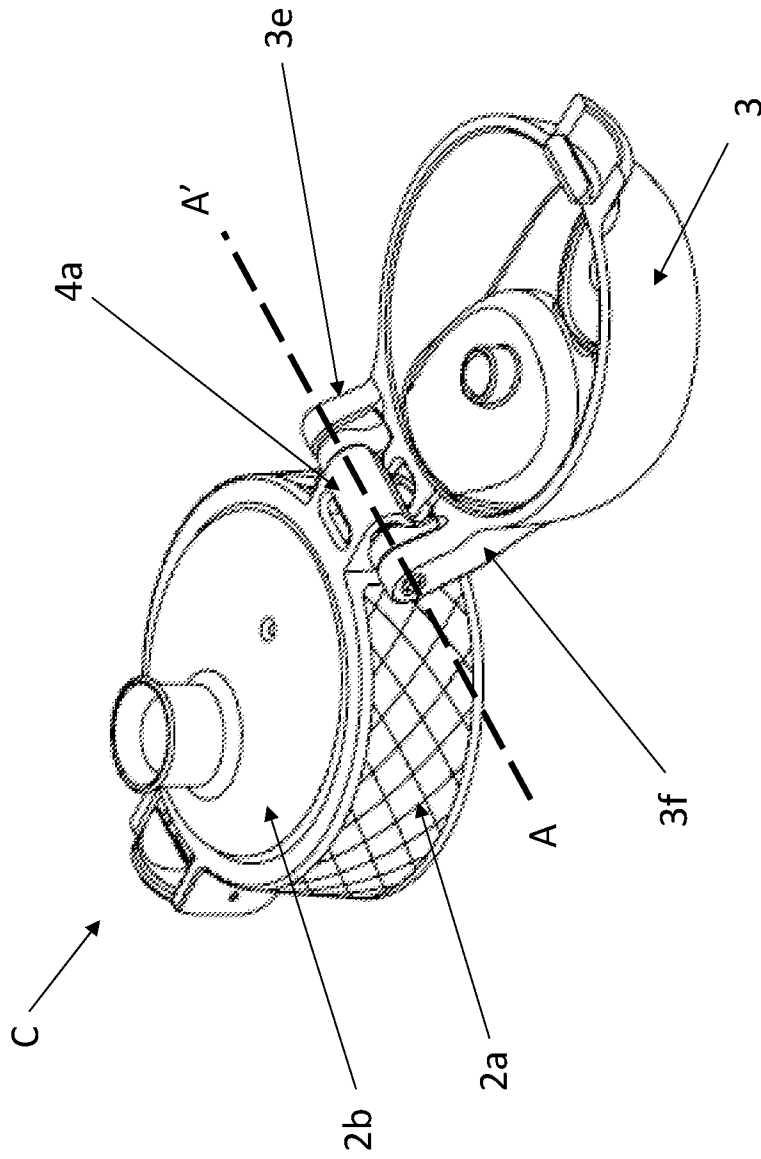

Figure 10

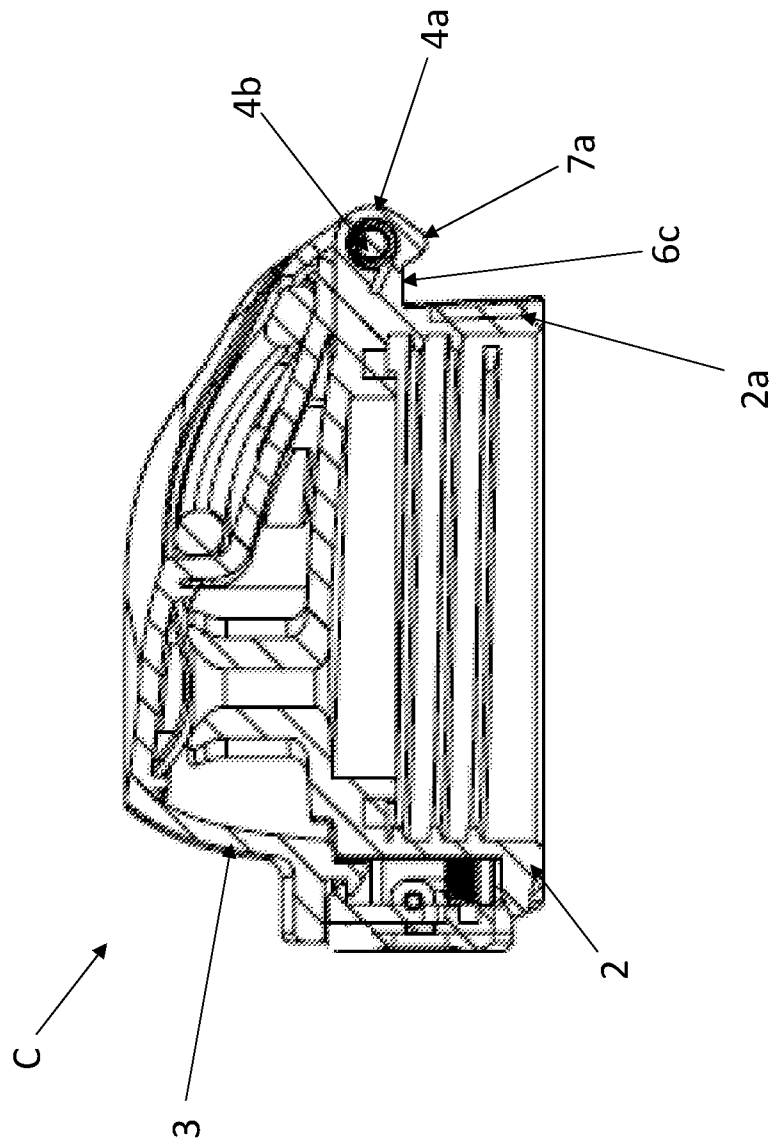

Figure 11

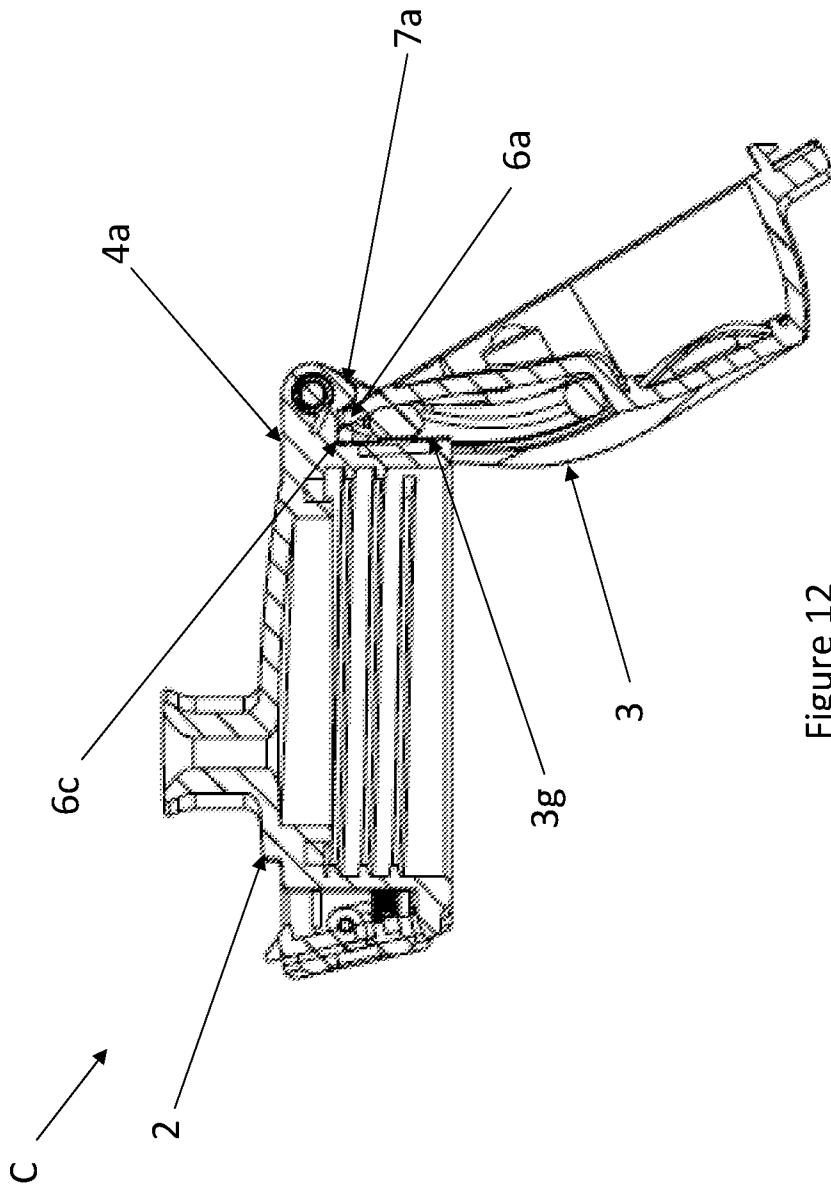

Figure 12

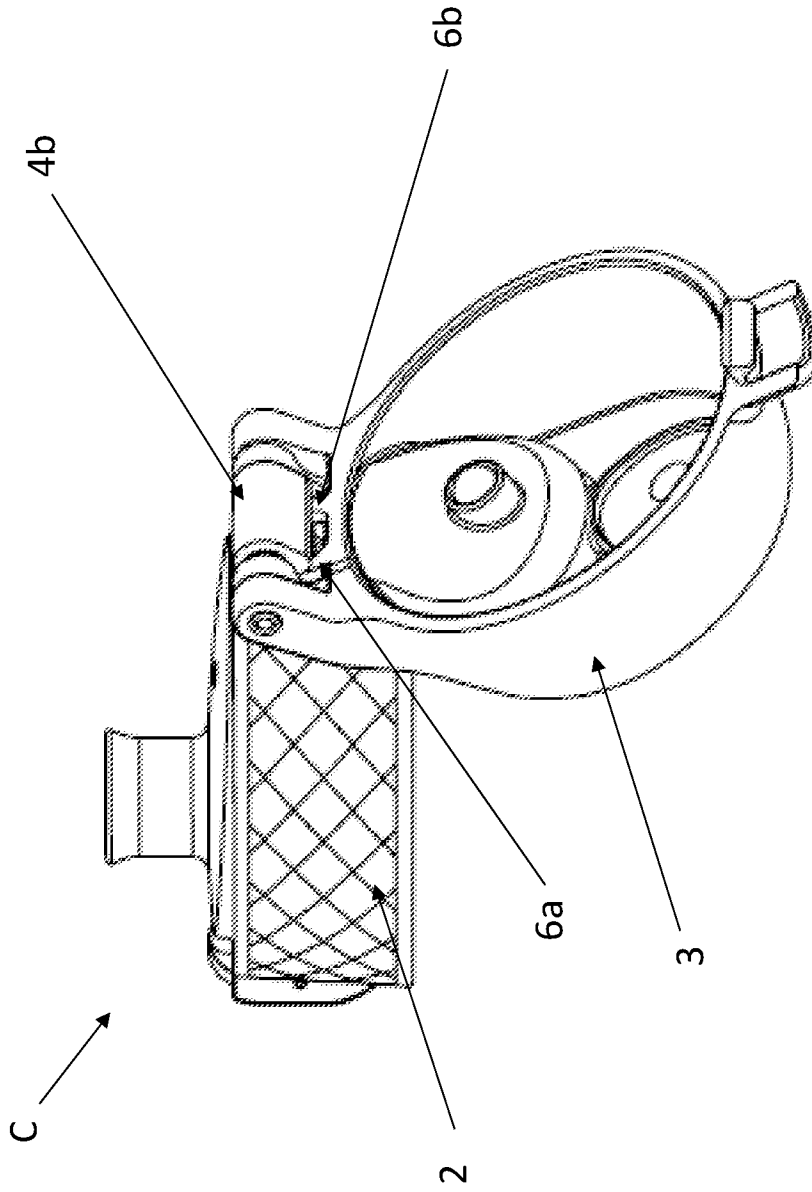

Figure 13

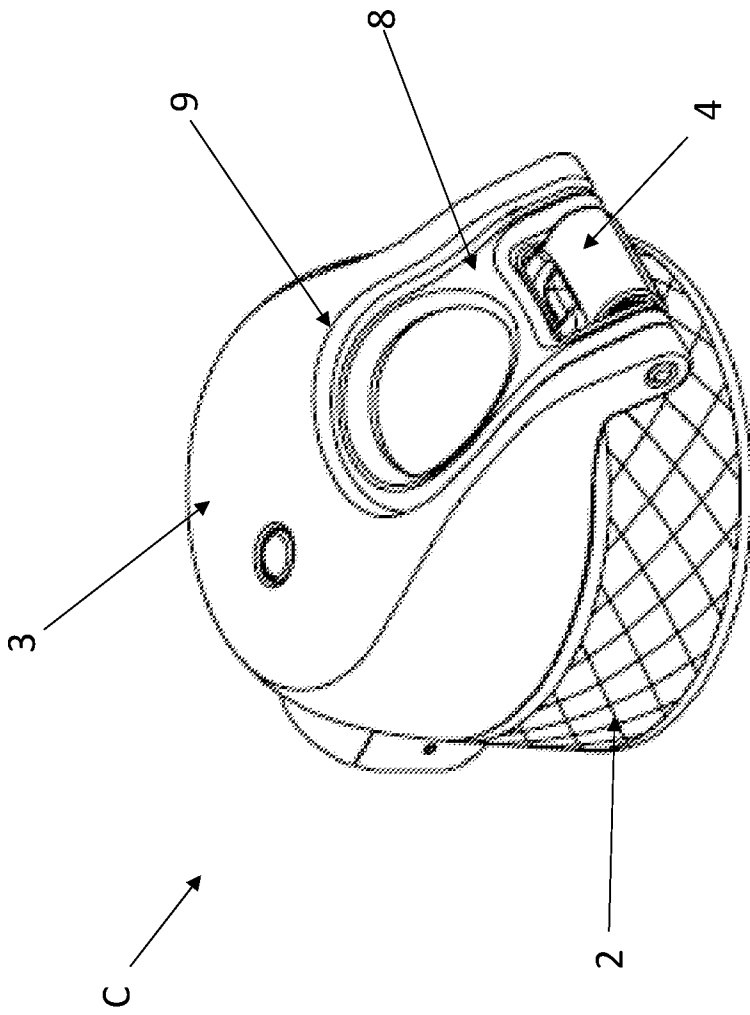

Figure 14

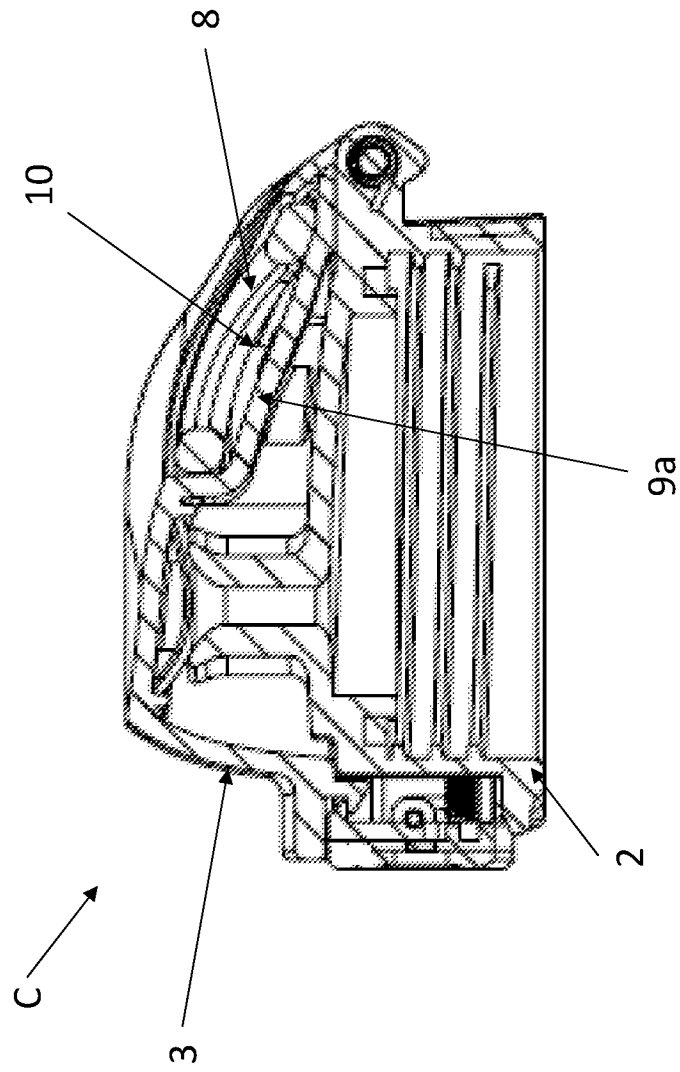

Figure 15

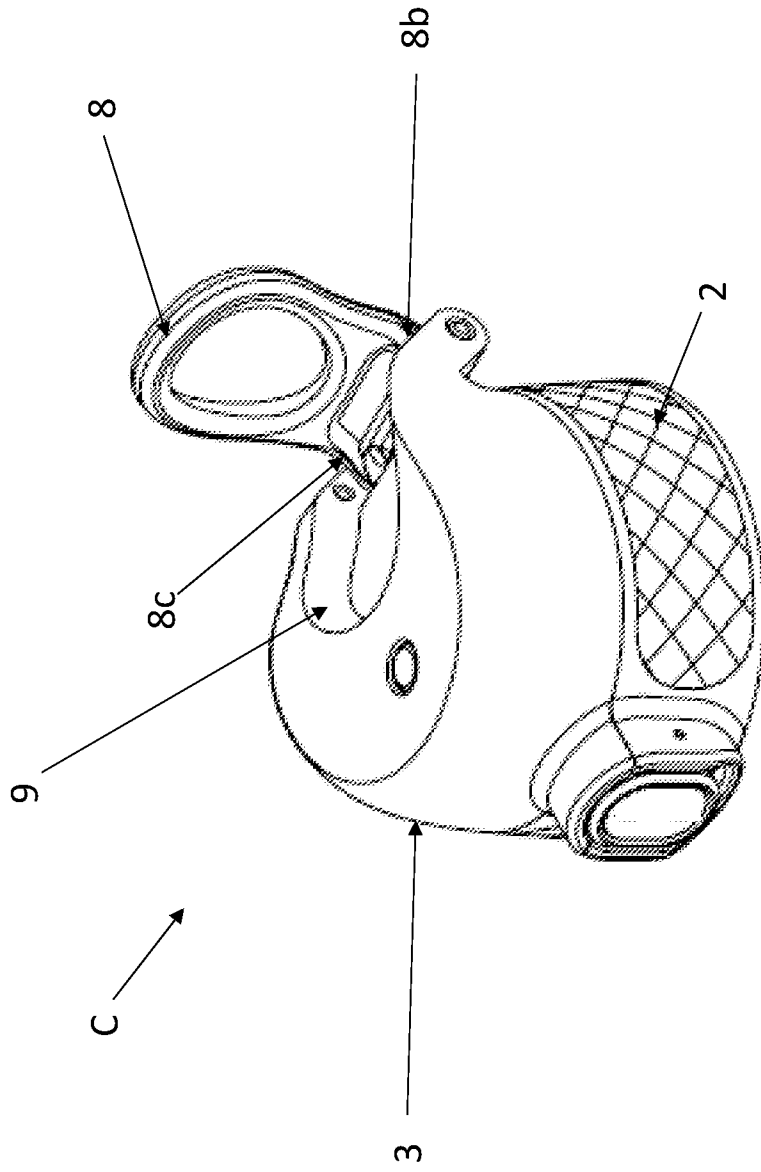

Figure 16

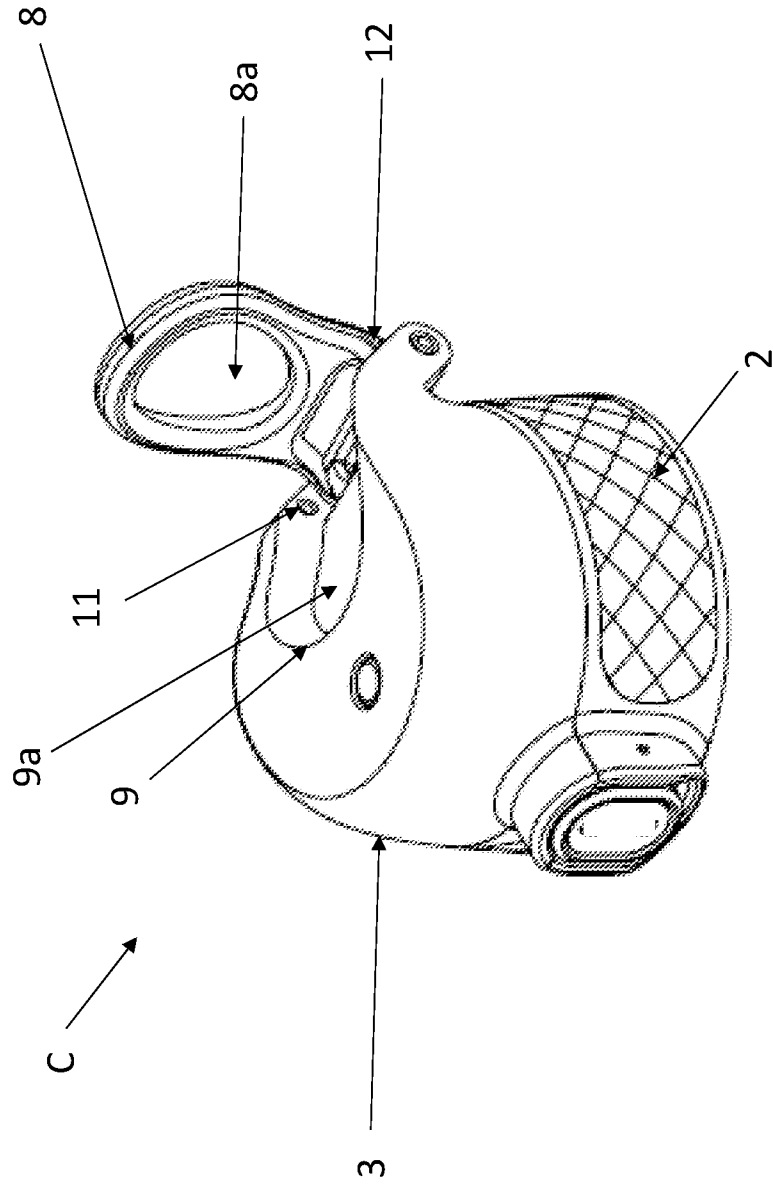

Figure 17

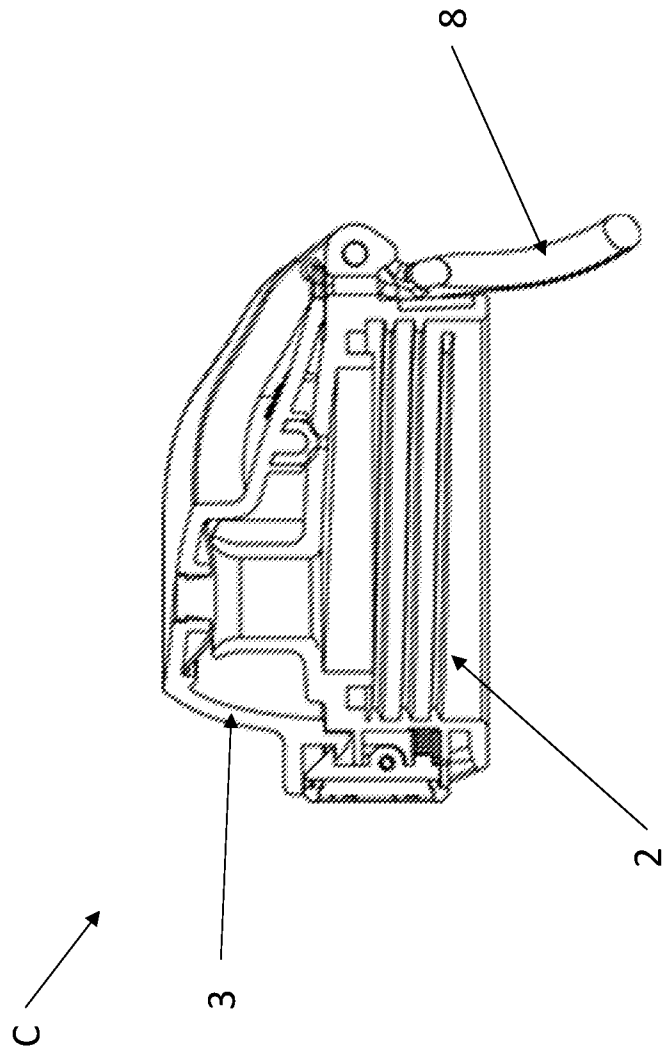

Figure 18

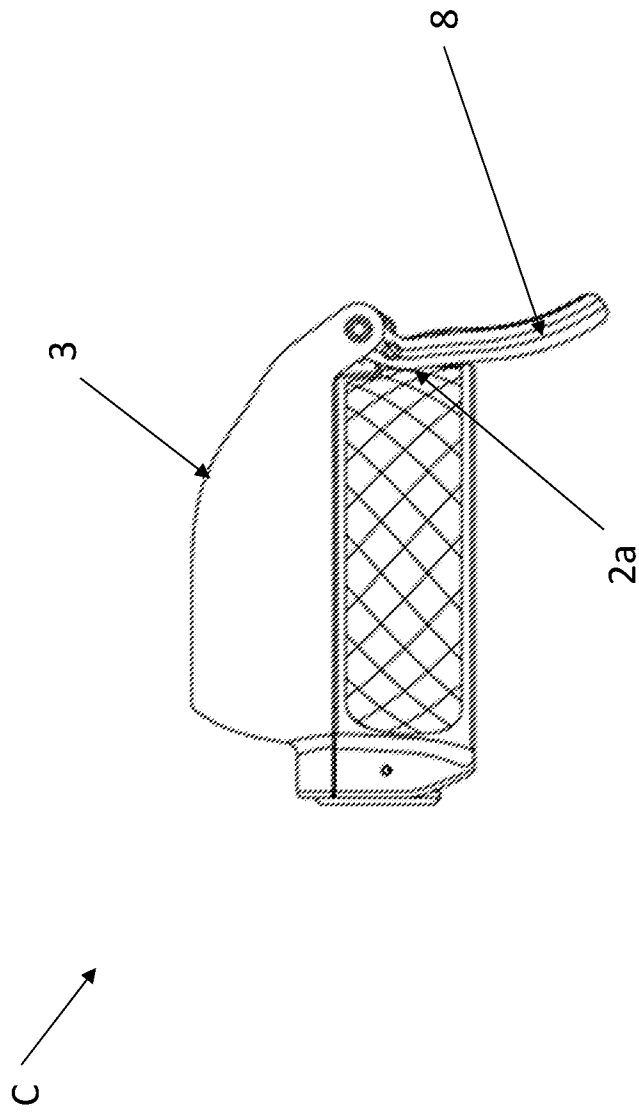

Figure 19

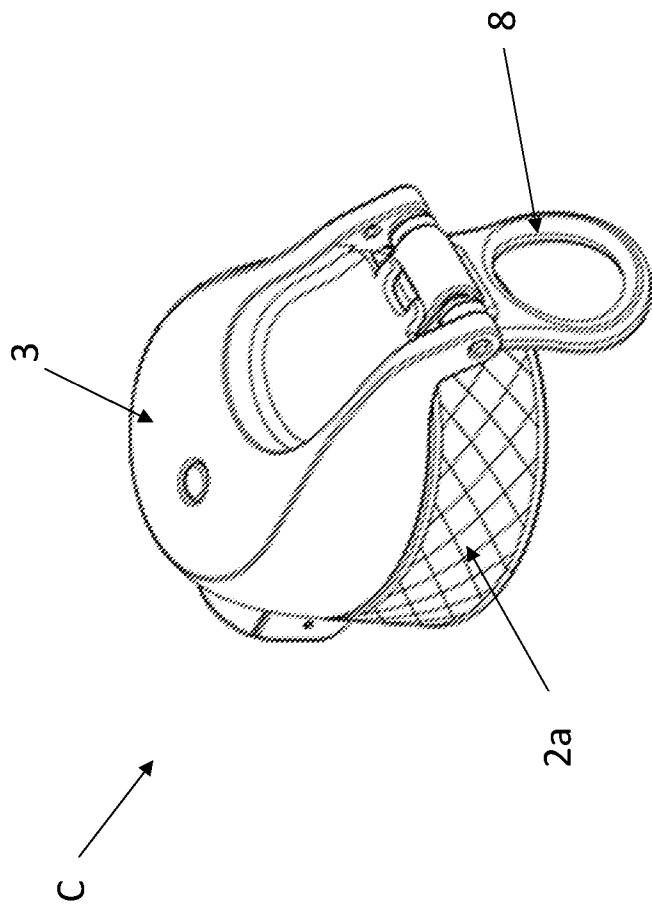

Figure 20

INTERNATIONAL SEARCH REPORT

International application No
PCT/GB2023/051560

A. CLASSIFICATION OF SUBJECT MATTER
INV. B65D51/24 B65D47/08 A47G19/30 A47G19/22 A45F3/18
ADD.

According to International Patent Classification (IPC) or to both national classification and IPC

B. FIELDS SEARCHED
 Minimum documentation searched (classification system followed by classification symbols)
B65D A47G A45F

Documentation searched other than minimum documentation to the extent that such documents are included in the fields searched

Electronic data base consulted during the international search (name of data base and, where practicable, search terms used)
EPO-Internal, WPI Data

C. DOCUMENTS CONSIDERED TO BE RELEVANT

| Category* | Citation of document, with indication, where appropriate, of the relevant passages | Relevant to claim No. |
|-----------|---------------------------------------------------------------------------------------------------------------------------------------------------|---------------------------|
| X | EP 0 616 589 B1 (LOWN JOHN M [US]; MAGUIRE PAUL R [US]) 10 June 1998 (1998-06-10) column 3, line 33 - column 5, line 28; figure 1 ----- | 1-3, 5, 20, 21 |
| X | EP 2 311 748 B1 (THERMOS LLC [US]) 9 October 2013 (2013-10-09) paragraph [0020] - paragraph [0028]; figure 4 ----- | 1-3, 5, 20, 21 |
| X | JP 2015 006658 A (THERMOS LLC) 15 January 2015 (2015-01-15) paragraph [0114] - paragraph [0123]; figure 41 ----- | 1, 2, 5, 6, 20, 21 |
| X | CN 205 053 621 U (SEIKILIFE HOUSEWARES CO LTD) 2 March 2016 (2016-03-02) figure 4 ----- | 1, 3-6, 20, 21 |
| | -/-- | |

Further documents are listed in the continuation of Box C. See patent family annex.

* Special categories of cited documents :

| | |
|---------------------------------------------------------------------------------------------------------------------------------------------------------------------------------------------------------------------------------------------------------------------------------------------------------------------------------------------------------------------------------------------------------------------------------------------------------------------------------------------------------------------------------------------------------------------------------------------------|-----------------------------------------------------------------------------------------------------------------------------------------------------------------------------------------------------------------------------------------------------------------------------------------------------------------------------------------------------------------------------------------------------------------------------------------------------------------------------------------------------------------------------------------------------------------------------------------------------------------------------------------------------------------------------------------------------------------|
| <p>"A" document defining the general state of the art which is not considered to be of particular relevance</p> <p>"E" earlier application or patent but published on or after the international filing date</p> <p>"L" document which may throw doubts on priority claim(s) or which is cited to establish the publication date of another citation or other special reason (as specified)</p> <p>"O" document referring to an oral disclosure, use, exhibition or other means</p> <p>"P" document published prior to the international filing date but later than the priority date claimed</p> | <p>"T" later document published after the international filing date or priority date and not in conflict with the application but cited to understand the principle or theory underlying the invention</p> <p>"X" document of particular relevance; the claimed invention cannot be considered novel or cannot be considered to involve an inventive step when the document is taken alone</p> <p>"Y" document of particular relevance; the claimed invention cannot be considered to involve an inventive step when the document is combined with one or more other such documents, such combination being obvious to a person skilled in the art</p> <p>"&" document member of the same patent family</p> |
|---------------------------------------------------------------------------------------------------------------------------------------------------------------------------------------------------------------------------------------------------------------------------------------------------------------------------------------------------------------------------------------------------------------------------------------------------------------------------------------------------------------------------------------------------------------------------------------------------|-----------------------------------------------------------------------------------------------------------------------------------------------------------------------------------------------------------------------------------------------------------------------------------------------------------------------------------------------------------------------------------------------------------------------------------------------------------------------------------------------------------------------------------------------------------------------------------------------------------------------------------------------------------------------------------------------------------------|

| | |
|--------------------------------------------------------------------------------------|-------------------------------------------------------------------------|
| Date of the actual completion of the international search 1 September 2023 | Date of mailing of the international search report 30/10/2023 |
|--------------------------------------------------------------------------------------|-------------------------------------------------------------------------|

| | |
|----------------------------------------------------------------------------------------------------------------------------------------------------------------------|-------------------------------------------------|
| Name and mailing address of the ISA/ European Patent Office, P.B. 5818 Patentlaan 2 NL - 2280 HV Rijswijk Tel. (+31-70) 340-2040, Fax: (+31-70) 340-3016 | Authorized officer Vistisen, Lars |
|----------------------------------------------------------------------------------------------------------------------------------------------------------------------|-------------------------------------------------|

INTERNATIONAL SEARCH REPORT

International application No
PCT/GB2023/051560

| C(Continuation). DOCUMENTS CONSIDERED TO BE RELEVANT | | |
|------------------------------------------------------|-------------------------------------------------------------------------------------------------------------------------------------------------------------------------|-----------------------|
| Category* | Citation of document, with indication, where appropriate, of the relevant passages | Relevant to claim No. |
| X | <p>JP 2008 125965 A (ZOJIRUSHI CORP) 5 June 2008 (2008-06-05) paragraph [0011] - paragraph [0015]; figures 1-3</p> <p style="text-align: center;">-----</p> | 1, 3-5, 20, 21 |
| X | <p>JP 2012 111498 A (THERMOS KK) 14 June 2012 (2012-06-14) paragraph [0035] - paragraph [0067]; figures</p> <p style="text-align: center;">-----</p> | 1, 3, 5, 20, 21 |
| A | <p>JP 3 937428 B2 (THERMOS KK) 27 June 2007 (2007-06-27) figure 1</p> <p style="text-align: center;">-----</p> | 4 |
| A | <p>JP 2005 193944 A (THERMOS KK) 21 July 2005 (2005-07-21) figure 2</p> <p style="text-align: center;">-----</p> | 4 |
| A | <p>DE 10 2006 060143 B3 (ALFI GMBH ISOLIERGEFAESE [DE]) 24 July 2008 (2008-07-24) figures 1, 2</p> <p style="text-align: center;">-----</p> | 1, 2 |

INTERNATIONAL SEARCH REPORT

International application No.
PCT/GB2023/051560

Box No. II Observations where certain claims were found unsearchable (Continuation of item 2 of first sheet)

This international search report has not been established in respect of certain claims under Article 17(2)(a) for the following reasons:

1. Claims Nos.:
because they relate to subject matter not required to be searched by this Authority, namely:

2. Claims Nos.:
because they relate to parts of the international application that do not comply with the prescribed requirements to such an extent that no meaningful international search can be carried out, specifically:

3. Claims Nos.:
because they are dependent claims and are not drafted in accordance with the second and third sentences of Rule 6.4(a).

Box No. III Observations where unity of invention is lacking (Continuation of item 3 of first sheet)

This International Searching Authority found multiple inventions in this international application, as follows:

see additional sheet

1. As all required additional search fees were timely paid by the applicant, this international search report covers all searchable claims.

2. As all searchable claims could be searched without effort justifying an additional fees, this Authority did not invite payment of additional fees.

3. As only some of the required additional search fees were timely paid by the applicant, this international search report covers only those claims for which fees were paid, specifically claims Nos.:

4. No required additional search fees were timely paid by the applicant. Consequently, this international search report is restricted to the invention first mentioned in the claims;; it is covered by claims Nos.:
1-6, 20 (completely); 21 (partially)

Remark on Protest

- The additional search fees were accompanied by the applicant's protest and, where applicable, the payment of a protest fee.
- The additional search fees were accompanied by the applicant's protest but the applicable protest fee was not paid within the time limit specified in the invitation.
- No protest accompanied the payment of additional search fees.

FURTHER INFORMATION CONTINUED FROM PCT/ISA/ 210

This International Searching Authority found multiple (groups of) inventions in this international application, as follows:

1. claims: 1-6, 20 (completely); 21 (partially)

Arrangement of the pivot axis with respect to the base upper wall in a cap assembly.

2. claims: 7-13 (completely); 21 (partially)

Aspects of a lock for locking the lid with respect to the base in a cap assembly.

3. claims: 14-19 (completely); 21 (partially)

Details of a handle for a cap assembly.

INTERNATIONAL SEARCH REPORT

Information on patent family members

International application No

PCT/GB2023/051560

| Patent document cited in search report | Publication date | Patent family member(s) | Publication date | |
|----------------------------------------|------------------|-------------------------|--------------------|------------|
| EP 0616589 | B1 | 10-06-1998 | AU 5329794 A | 09-05-1994 |
| | | | CA 2125560 A1 | 28-04-1994 |
| | | | DE 69319087 T2 | 08-10-1998 |
| | | | EP 0616589 A1 | 28-09-1994 |
| | | | US 5305900 A | 26-04-1994 |
| | | | US 5320232 A | 14-06-1994 |
| | | | WO 9408865 A1 | 28-04-1994 |
| | | | ----- | |
| EP 2311748 | B1 | 09-10-2013 | AR 078524 A1 | 16-11-2011 |
| | | | AU 2010224375 A1 | 12-05-2011 |
| | | | CA 2716398 A1 | 15-04-2011 |
| | | | CL 2010001122 A1 | 11-03-2011 |
| | | | EP 2311748 A1 | 20-04-2011 |
| | | | PE 20110376 A1 | 22-06-2011 |
| | | | US 2011089059 A1 | 21-04-2011 |
| | | | ----- | |
| JP 2015006658 | A | 15-01-2015 | AU 2014202683 A1 | 04-12-2014 |
| | | | CA 2851875 A1 | 20-11-2014 |
| | | | CN 104172723 A | 03-12-2014 |
| | | | EP 2805921 A1 | 26-11-2014 |
| | | | HK 1200674 A1 | 14-08-2015 |
| | | | JP 6226812 B2 | 08-11-2017 |
| | | | JP 2015006658 A | 15-01-2015 |
| | | | KR 20140136397 A | 28-11-2014 |
| | | | MX 346484 B | 22-03-2017 |
| | | | PH 12014000146 A1 | 02-12-2015 |
| | | | SG 10201402468U A | 30-12-2014 |
| | | | US 2014339177 A1 | 20-11-2014 |
| | | | WO 2014189958 A2 | 27-11-2014 |
| | | | ----- | |
| CN 205053621 | U | 02-03-2016 | CN 205053621 U | 02-03-2016 |
| | | | JP 3202797 U | 25-02-2016 |
| ----- | | | | |
| JP 2008125965 | A | 05-06-2008 | NONE | |
| ----- | | | | |
| JP 2012111498 | A | 14-06-2012 | CN 102556483 A | 11-07-2012 |
| | | | JP 5310704 B2 | 09-10-2013 |
| | | | JP 2012111498 A | 14-06-2012 |
| | | | TW 201242853 A | 01-11-2012 |
| ----- | | | | |
| JP 3937428 | B2 | 27-06-2007 | CN 1432512 A | 30-07-2003 |
| | | | CN 1990354 A | 04-07-2007 |
| | | | JP 3937428 B2 | 27-06-2007 |
| | | | JP 2003212258 A | 30-07-2003 |
| | | | TW I298247 B | 01-07-2008 |
| | | | US 2003136783 A1 | 24-07-2003 |
| ----- | | | | |
| JP 2005193944 | A | 21-07-2005 | CA 2491577 A1 | 07-07-2005 |
| | | | CN 1636835 A | 13-07-2005 |
| | | | JP 2005193944 A | 21-07-2005 |
| | | | TW I321117 B | 01-03-2010 |
| ----- | | | | |
| DE 102006060143 | B3 | 24-07-2008 | CH 700493 B1 | 15-09-2010 |
| | | | CN 201301049 Y | 02-09-2009 |
| | | | DE 102006060143 B3 | 24-07-2008 |
| ----- | | | | |