

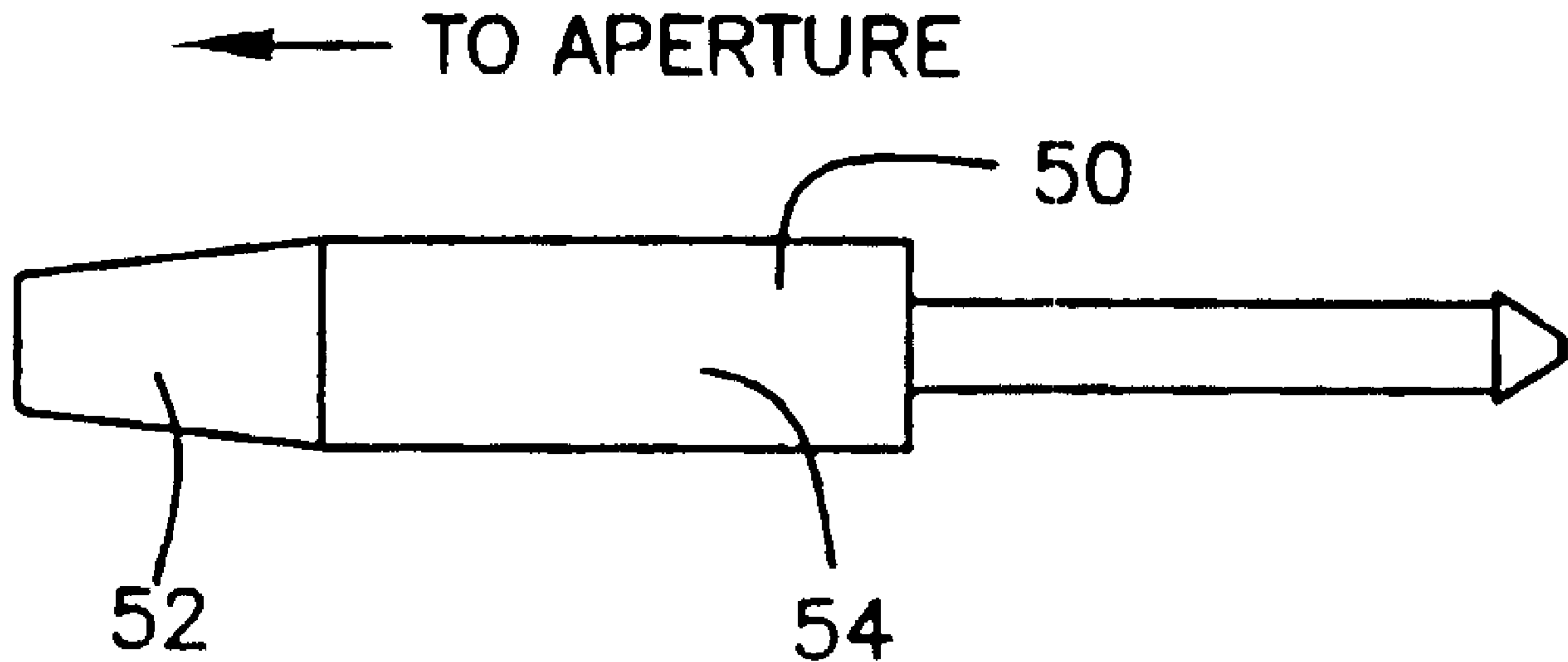

(22) Date de dépôt/Filing Date: 2002/09/03
(41) Mise à la disp. pub./Open to Public Insp.: 2003/03/10
(30) Priorité/Priority: 2001/09/10 (09/949,547) US

(51) Cl.Int.⁷/Int.Cl.⁷ B65G 39/02
(71) Demandeur/Applicant:
FKI LOGISTEX AUTOMATION DIVISION, A DIVISION
OF FKI INDUSTRIES, INC., US
(72) Inventeurs/Inventors:
HENSON, MARK W., US;
MOSER, MICHAEL E., US;
HOOLE, JONATHAN, US;
PATRICK, JAMES T., US
(74) Agent: MACRAE & CO.

(54) Titre : ROULEMENT CARTOUCHE A DEMI-ESSIEU ET ESSIEU ELECTROCONDUCTEUR, ET METHODE
D'UTILISATION DU ROULEMENT CARTOUCHE
(54) Title: CARTRIDGE BEARING INCLUDING A STUB SHAFT AND AN ELECTRICALLY CONDUCTIVE AXLE AND
METHOD OF USING CARTRIDGE BEARING



(57) Abrégé/Abstract:

The invention is particularly useful for coating with roller tubes of conveyor apparatus. A cartridge bearing including a stub axle with a tip of greater hardness than the surface circumscribing the aperture receiving the stub axle is inserted into an end of a conveyor roller tube. Along with being electrically conductive, the stub axle can be provided with a damper for reducing vibration. The stub axle engages an electrically conductive stub shaft and moves axially with respect to the stub shaft to operatively interlock with the aperture of the fixed structure. Use of the cartridge bearing provides for the grounding of static charge that can accumulate during operation of conveyor roller tubes.

1

2 ABSTRACT OF DISCLOSURE

3

4 The invention is particularly useful for coacting with roller tubes of conveyor
5 apparatus. A cartridge bearing including a stub axle with a tip of greater hardness than the
6 surface circumscribing the aperture receiving the stub axle is inserted into an end of a
7 conveyor roller tube. Along with being electrically conductive, the stub axle can be
8 provided with a damper for reducing vibration. The stub axle engages an electrically
9 conductive stub shaft and moves axially with respect to the stub shaft to operatively
10 interlock with the aperture of the fixed structure. Use of the cartridge bearing provides for
11 the grounding of static charge that can accumulate during operation of conveyor roller tubes.

1 ***CARTRIDGE BEARING INCLUDING A STUB SHAFT AND AN***
2 ***ELECTRICALLY CONDUCTIVE AXLE AND METHOD OF USING***
3 ***CARTRIDGE BEARING***

4
5 **BACKGROUND OF THE INVENTION**

6
7 1. Field of the Invention

8 The present invention relates to stub axles and stub shafts that are utilized primarily
9 in combination with cartridge bearings. Generally, the cartridge bearing combination is
10 sized for coacting with an end of conventional roller tubes mounted to conveyor frames.
11 Although the stub axle is retractable, the spring positioned inside the stub shaft normally
12 urges the stub axle toward its corresponding aperture located in the conveyor's frame.
13 Along with being anchored to the stub shaft, the stub axle is also provided with a tip that is
14 harder than the exposed surface circumscribing its corresponding aperture of the frame's
15 fixed structure. The harder tip positioned near the end of the stub axle functionally or
16 operatively interlocks the aperture to reduce scoring of the stub axle caused by operational
17 vibrations of the conveyor. Along with increasing the longevity of the stub axle, the harder
18 tip provides for easier removal of the stub axle from the frame, since the scoring of the stub
19 axle has been reduced. In select embodiments, a nonmetallic damper is located between the
20 stub axle's body and tip for reducing vibration between the stub axle and the conveyor
21 frame.

22 2. Description of the Previous Art

23 a) US Patent 6,053,298-Nimmo, et. al., discloses a conveyor roller assembly.
24 Roller tube (16) is rotably supported by bearing unit (20) that includes a ball bearing (22)
25 having an outer race confined within an annular adapter bushing (24) molded of a rigid
26 plastics material such as polypropylene and reinforced with glass fibers. A hexagonal stub
27 shaft (60) is also molded of the same plastic material as the bushing. Each stub axle (60) is
28 normally retained in its outwardly projecting position by a coil spring (68) located within
29 shaft (35). The shaft member (35) defines an internal hexagonal chamber (52) and a slightly
30 smaller hexagonal bore (54) with the collapsible outer portion of the shaft member.
31 Additionally, the stub axle (60) has a twisted and tapered outer tip portion (62) with a
32 hexagonal outer end surface (63). Nimmo's rigid plastics material includes sufficient
33 carbon particles to allow for dissipation of electrostatic charge.

-2-

1 b) US Patent 4,421,442-Agnoff describes a conveyor roller tube that has a
2 tapered shuttle for engaging the conveyor's frame. A roller (10) is mounted between the
3 frame members (12) via an axially moveable shuttle (30) at the ends of the roller shaft (18).
4 The shuttle (30) is adapted to engage its corresponding mounting hole (14) in the frame.
5 Agnoff's shuttle body (32) slides freely within the roller shaft (18) and has a polygonal
6 tapered end portion (34) that is narrower than the body (32) so that a shoulder (36) is created for
7 engaging snap ring (38). Springs (42) always bias shuttles (30) toward their corresponding
8 mounting holes (14). And in Column, lines 59-64, Agnoff declares, "The combination of
9 the spring 42 and the tapered end 34 of the shuttle eliminates any play between the shuttle
10 30 and the mounting hole 14. As a result, vibration and movement of the roller shaft 18 is
11 substantially reduced."

12 c) US Patent 5,865,290-Scott enables a conveyor roller insert. Scott's cartridge
13 has an outboard bearing (50) and inboard bearing (64). A stub axle (28) having a
14 hex-shaped tip (30) is positioned axially within the cartridge (12) and roller tube (14). The
15 tip (30) has a tapered portion (32) and projects outwardly from the cartridge (12) for
16 inserting into a corresponding mounting hole (34). Scott incorporates a coil spring (40) for
17 biasing the stub axle (28) into its corresponding mounting hole (34).

18 d) US Patent 6,076,647-Agnoff discloses a stub shaft conveyor roller. The
19 roller tube (20) is journaled on a pair of stub shafts (50). Agnoff's stub shaft (50) and
20 bearing shield (40) are biased by a spring (60) to an extended position. Among other things,
21 stub shaft (50) includes a cylindrical inner portion (52) journaled in bearing (38) and an
22 outer hexagonal portion (54) adapted to mate with a similarly sized opening (14) of the
23 mounting frame (12). Agnoff's outer portion (54) also has a threaded hole (58) for
24 receiving a bolt (62) which extends from outside the frame (12) into the hole.

25 e) US Patent 4,664,243-Martin enables a polymeric conveyor roller, a
26 polymeric spherical bearing and a spring loaded retractable shaft.

27 f) US Patent 5,678,676-Pierson, among other things, teaches a method and
28 apparatus for utilizing bushings to attach a conveyor roller rotatably mounted on a through
29 shaft to the conveyor frame. The bushing (36) is slipped over the end of shaft (14) and the
30 tapered outer surface (41) of the tapered legs (40) are squeezed together to grip the roller
31 shaft as it is inserted to the conveyor frame. When the bushing's latches (39) and latching
32 legs (38) are pressed through the hole, the latches (39) catch on the inner side (43) of the
33 frame member to hold the bushing in place. The gripping action of the tapered legs (40) on
34 the roller shaft greatly reduces vibration, and the bushing (36) eliminates the metal on metal

1 contact between the shaft (14) and the mounting hole (22). In another embodiment, Pierson
2 attaches a plastic cone (35) onto the roller shaft (14). And in yet another embodiment, the
3 '063 Patent discloses biasing the tapered end of the through shaft (14) into mounting hole
4 (22) to reduce vibration of the shaft (14) in both mounting holes (22) and (32).

5 g) US Patent 5,875,878-Pierson is a Patent that issued from the divisional
6 application from which US Patent 5,678,676-Pierson also issued.

7 h) US Patent 3,353,644-McNash, et. al., among other things, enables a conveyor
8 roller formed of plastic components.

9 i) US Patent 3,610,387-Von Stein enables a conveyor roller. The Von Stein
10 shaft (6) has a blind bore (40) that reciprocates with an axially movable plunger (42). A
11 helical expansion spring (45) is inserted into the blind bore (40) to bias the head (44) of
12 plunger (42) into hole (102) of frame.

13

SUMMARY OF THE INVENTION

1
2
3 Unlike traditional stub axles for cartridge bearings, the present apparatus includes a
4 tip harder than the surface circumscribing the aperture of the fixed structure into which the
5 stub axle it is to be inserted or a damper or both. Hexagonal and other tapered tips of the
6 stub axle are sized for operatively interlocking with an aperture of the conveyor frame.
7 Both the stub shaft and the stub axle engaging the stub shaft are electrically conductive to
8 assist in grounding the static charge frequently generated by conveyor roller tubes. The
9 cartridge's housing can be supported by a single ball bearing, a ball bearing and a journal
10 bearing, or by two ball bearings. Along with supporting the housing, the bearing or bearings
11 journal the hollow stub shaft. A spring can be inserted into a chamber of the stub shaft to
12 urge the stub axle axially outward and toward its corresponding aperture, and the stub axle
13 can also be provided with an anchor for securing the stub axle.

14 An object of the present invention is to provide a cartridge bearing for coaxing with
15 a conveyor roller tube.

16 It is another object of the present invention to enable a method of using the cartridge
17 bearing.

18 Still another object of the present invention is to provide a stub axle having a tip or
19 tip zone with greater hardness than the surface circumscribing the aperture that is
20 operatively interlocked with the stub axle.

21 Yet another object of the present invention is to provide a stub axle having a damper
22 or damper zone capable of reducing vibration associated with conveyor rollers.

23 Still another object of the present invention is to provide an axially movable
24 electrically conductive axle.

25 Yet still another object of the present invention is provide a metallic axially movable
26 electrically conductive axle.

27 It is yet another object of the present invention to provide a nonmetallic axially
28 movable electrically conductive axle.

29 Still another object of the present invention is to provide an axially movable
30 electrically conductive axle that is part metallic and part nonmetallic.

31 An embodiment of the present invention can be described as a spring-assisted axially
32 movable electrically conductive axle extending outwardly from a hollow shaft journaled in a
33 bearing for operatively interlocking an aperture of a fixed structure comprising: a body
34 engaging the hollow shaft with a tip projecting outwardly from the hollow shaft for

1 operatively interlocking with the aperture, wherein the tip is harder than the exposed surface
2 of the aperture and a nonmetallic damper positioned between said tip and said body.

3 Another embodiment of the present apparatus can be described an insertable
4 cartridge coacting with a tube, comprising: a housing; a bearing supporting the housing and
5 journaling the stub shaft; a spring for urging an axially movable electrically conductive
6 axle into an operative interlocking with an aperture of a frame, wherein the axially movable
7 electrically conductive axle further includes: a body engaging the stub shaft and a tip
8 projecting outwardly from the stub shaft for operatively interlocking with the aperture and a
9 nonmetallic damper positioned between said tip and said body.

10 Yet another embodiment of the present device can be described as an insertable
11 cartridge coacting with a conveyor roller tube, comprising: a housing; an inboard bearing
12 and an outboard ball bearing supporting the housing and journaling a stub shaft; a spring
13 for urging an axially movable electrically conductive axle into an operative interlocking
14 with an aperture of a conveyor frame, and wherein the axially movable electrically
15 conductive axle further includes: a body engaging the stub shaft, a tapered tip projecting
16 outwardly from the stub shaft for operatively interlocking with the aperture and a
17 nonmetallic damper positioned between the tapered tip and the body.

18 In still another embodiment, the present invention can be described as an insertable
19 cartridge coacting with a conveyor roller tube, comprising: a housing; an inboard ball
20 bearing and an outboard ball bearing supporting the housing and journaling a stub shaft
21 having a chamber including a spring for urging an axially movable electrically conductive
22 axle into an operative interlocking with an aperture, and wherein the axially movable
23 electrically conductive axle further includes: a metallic body engaging the
24 electrically conductive nonmetallic stub shaft and a metallic hexagonal tapered tip
25 projecting outwardly from the stub shaft for operatively interlocking with the aperture of
26 said frame such that the metallic tapered tip of the axially movable electrically conductive
27 axle is harder than an exposed surface of the aperture.

28 Yet still another embodiment can be described as an insertable cartridge coacting
29 with a conveyor roller tube, comprising: a housing; an inboard ball bearing and an outboard
30 ball bearing supporting said housing and journaling a stub shaft having a spring for urging a
31 hexagonal axially movable electrically conductive axle into an operative interlocking with
32 an aperture, wherein the hexagonal axially movable electrically conductive axle further
33 includes: a body engaging the stub shaft and a metallic tapered tip harder than an exposed

1 surface of the aperture projecting outwardly from the stub shaft for operatively interlocking
2 with the aperture and a nonmetallic damper positioned between the tapered tip and the body.

3 Still another embodiment of the present invention can be described as a method of
4 operatively interlocking a tip of an electrically conductive axle to an aperture of a conveyor
5 frame for reducing vibration and noise of a conveyor roller, comprising the steps of:
6 inserting a cartridge including a ball bearing into an end of a conveyor roller; supporting the
7 cartridge from said ball bearing; journaling a stub shaft in the ball bearing; loading a spring
8 into the stub shaft for urging said electrically conductive axle body toward said aperture;
9 incorporating a tip on said electrically conductive axle body, wherein said tip is harder than
10 an exposed surface of said conveyor's frame circumscribing said aperture; positioning a
11 damper between the tip and the electrically conductive axle body; and operatively
12 interlocking the tip of said electrically conductive axle body with the aperture.

13 It is the novel and unique interaction of these simple elements which creates the
14 apparatus and methods, within the ambit of the present invention. Pursuant to Title 35 of
15 the United States Code, descriptions of preferred embodiments follow. However, it is to be
16 understood that the best mode descriptions do not limit the scope of the present invention.

BRIEF DESCRIPTION OF THE DRAWINGS

1
2
3 **Fig. 1 is a representation of an embodiment of a stub axle having two zones, within**
4 **the scope of the present invention.**

5 **Fig. 2 is another representation of a stub axle having three zones, within the ambit of**
6 **the present invention.**

7 **Fig. 3 is a lateral view of a stub axle engaging the stub shaft, in accordance with the**
8 **present invention.**

9 **Fig. 4 is lateral view of another embodiment of the stub axle engaging the stub shaft**
10 **of the present invention.**

11 **Fig. 5 is a frontal view of the stub axle engaging the stub shaft, within the scope of**
12 **the present invention.**

13 **Fig. 6 is a representation of a hexagonal tip of the stub axle having a separately**
14 **attached tip and damper.**

15 **Fig. 7 is lateral view showing a relationship between the tip of a stub axle and the**
16 **frame, when the tip is initially inserted in the aperture.**

17 **Fig. 8 is lateral view showing a the scoring of the tip of a traditional stub axle.**

18 **Fig. 9 is lateral view showing an operative interlocking of the present stub axle with**
19 **the corresponding aperture of a frame.**

20 **Fig. 10 is a top view cut away of an extended stub axle embodiment of the present**
21 **invention.**

22 **Fig. 11 is an external view of the cartridge bearing, within the scope of the present**
23 **invention.**

24 **Fig. 12 is a top view cut away of another extended stub axle embodiment of the**
25 **present invention.**

26 **Fig. 13 is a top view cut away of an operatively interlocked embodiment of the**
27 **present invention.**

28 **Fig. 14 is an inboard end pictorial of an embodiment incorporating the detent of the**
29 **present invention.**

30 **Fig. 15 is an illustration of the steps of an embodiment of the present method.**

31 **Fig. 16 is a depiction of the steps of another embodiment of the present invention.**

32 **Fig. 17 is an exemplification of the steps of yet another embodiment of the current**
33 **method.**

1 **Fig. 18 is a diagrammatic representation of the steps of still another embodiment of**
2 **the present invention.**

3 **Fig. 19 is an illustration of the steps of yet another embodiment of the present**
4 **method.**

5

DESCRIPTION OF THE PREFERRED EMBODIMENTS

1
2
3 Although the disclosure hereof is detailed to enable those skilled in the art to
4 practice the invention, the embodiments published herein merely exemplify the present
5 invention.

6 Fig. 1 depicts a simplified embodiment of an all metallic stub axle of the present
7 invention that is subdivided into two zones. Stub axle (50) is divided into tip zone (52) and
8 body zone (54). Body zone (54) is of a lesser hardness than tip zone (52) which is of greater
9 hardness than the aperture of the fixed structure (not shown) into which stub axle (50) is to
10 be inserted.

11 Fig. 2 portrays another simplified embodiment of the stub axle that has been divided
12 into three zones. As shown, stub axle (50) includes tip zone (52), body zone (54) and
13 damper zone (56). Within the ambit of the present invention, zones (52), (54) and (56) can
14 be composed as follows:

- 15 a) zones (52), (54) and (56) are nonmetallic; or
16 b) zone (52) is metallic and zones (54) and (56) are nonmetallic; or
17 c) zone (52) and (56) are metallic and zone (54) is nonmetallic.

18 Regardless of the composition of the respective zones (52), (54) and (56), tip zone
19 (52) has a hardness greater than the aperture of the fixed structure (not shown) into which
20 stub axle (50) is to be operatively inserted while body zone (54) is of lesser hardness than
21 tip zone (54). In this specific embodiment, when stub axle (50) is operatively interlocked
22 with an aperture, damper zone (56) is resilient enough to absorb some of the shock
23 generated between the stub axle and the conveyor frame (not shown).

24 In Fig. 3, an embodiment of the present invention utilizing stub axle (50) including
25 tip (52), body (54) and damper (56) that has been inserted into hollow stub shaft (60) is
26 disclosed. Body (54) engages stub shaft (60) while tip (52) projects outwardly from hollow
27 stub shaft (60) for operatively interlocking with an aperture of the fixed structure (not
28 shown), such as, a conveyor frame. Positioned between tip (52) and body (54) is damper
29 (56), and as shown, tip (52) is tapered. As enabled in Figs. 1 and 2, tip zone (52) and
30 damper zone (56) can be fabricated into a sole stub axle (50), including tip (52), body (54)
31 and damper (56). However, those skilled in the art recognize that stub axle (50) can be
32 dimensioned such that tip (52), or tip (52) and damper (56), are secured as separate
33 components to body (54) of stub axle (50).

1 Anchor (64) securing stub axle (50) is shouldered in inboard end (66) of hollow stub
2 shaft (60). Hook (70) of anchor (64) securely engages inboard end (66) of hollow stub shaft
3 (60) that is external to chamber (68). Spring (62) is positioned in chamber (68) of hollow
4 stub shaft such that stub axle (50) is urged axially outwardly from hollow stub shaft (60).

5 In Fig. 4, an all metallic stub axle (50) embodiment including tapered tip (52), body
6 (54), anchor (64) and hook (70) is depicted. Body (54) of stub axle (50) engages hollow
7 stub shaft (60) while tapered tip (52) projects outwardly from hollow stub shaft (60) for
8 operatively interlocking with an aperture of the conveyor frame (not shown). Spring (62) is
9 positioned in chamber (68) of hollow stub shaft such that stub axle (50) is urged axially
10 outwardly from hollow stub shaft (60). Anchor (64) secures stub axle (50) and is
11 shouldered in inboard end (66) of hollow stub shaft (60) while hook (70) of anchor (64)
12 securely engages inboard end (66) of hollow stub shaft (60) that is external to chamber (68).
13 As shown in Fig. 4, stub axle (50) is a sole axle including tip zone (52) and body zone (54).
14 However, those skilled in the art recognize that stub axle (50) can be dimensioned such that
15 tip (52) is a separately secured component of stub axle (50).

16 In Fig. 5, a frontal axial view of an embodiment of the present invention including a
17 hexagonal tapered tip (52) for operative insertion into the aperture of the conveyor frame is
18 set forth. Stub axle snugly engages chamber (68) of hollow stub shaft (60), thereby
19 reducing vibration associated with conveyor rollers. In yet another embodiment, as shown
20 in Fig. 6, stub axle (50) includes hexagonally tapered tip (52) and damper (56) that have
21 been separately attached to body (54) where tapered tip (52) and damper (56) have been
22 sized for operative insertion into the aperture of the conveyor frame (not shown).

23 As previously indicated, whether metallic or nonmetallic, tapered tip (52) has a
24 greater hardness than the corresponding aperture of the conveyor frame (not shown) into
25 which it is operatively inserted. It has been unexpectedly determined that tips of such
26 hardness reduce scoring of their corresponding axles as well as enhance operative
27 interlocking with their corresponding apertures. In other words, in accordance with the
28 present invention, stub axles seat into the conveyor frame rather than wear away from the
29 conveyor frame.

30 As is well known in the art, Fig. 7 portrays an interlocking between tip (120) and
31 frame (110), when the tip (120) is initially inserted into aperture (112) of frame (110). Prior
32 to the current invention that incorporates the hardened tip zone and as portrayed in Fig. 8,
33 operation of the conveyor roller resulted in the harder frame (110) scoring the softer tip
34 (120) along area (122). However, as depicted in Fig. 9 and in accordance with the present

1 invention, after use of the conveyor roller, aperture (94) of frame (92) conforms to the
2 structure of hardened tip (52) of stub axle (50). Thus, as shown in Fig. 9, hardened tip (52)
3 can operatively interlock along scoring area (96) while simultaneously leaving clearance
4 (98) between aperture (94) and tip (52).

5 With a view toward Fig. 10, another embodiment of the current invention is shown.
6 Ball bearing (72) supports housing (90) and journals stub shaft (60). Housing (90) is a
7 plastic or a plastic-like composition while stub shaft (60) is formed of plastic. Plastics
8 incorporated into the present invention further include the capability of assisting in the
9 grounding of static charge generated by the conveyor roller tubes.

10 As depicted in Fig. 11, hollow shaft (60) extends axially through housing (90).
11 Tapered tip (52) protrudes outwardly from hollow shaft (60) on the outboard side of housing
12 (90) while hook (70) of anchor (64) is attached to inboard end (66) of stub shaft (60) on the
13 inboard side of housing (90). In operation, housing (90) can be inserted into the end of a
14 conveyor roller tube.

15 Returning to Fig. 10, body (54) of stub axle (50) engages hollow stub shaft (60)
16 while tapered tip (52) and damper (56) project outwardly from hollow stub shaft (60) for
17 operatively interlocking with an aperture of the conveyor frame. Although Fig. 10 depicts
18 separately attached tapered tip (52) and damper (56), stub axle (50) can also be constructed
19 in any of the previously identified configurations and still function within the scope of the
20 present invention. Spring (62) is positioned in chamber (68) of hollow stub shaft (60) such
21 that stub axle (50) is urged axially outwardly from hollow stub shaft (60) while anchor (64)
22 secures stub axle (50). Anchor (64) is shouldered in inboard end (66) of hollow stub shaft
23 (60) while hook (70) of anchor (64) securely engages inboard end (66). Anchor (64) can be
24 attached to body (54) or anchor (64) can be manufactured as an extension of body (54).
25 Thus, anchor (64) can be of a different composition than body (54).

26 In Fig. 12, another embodiment of the present invention is disclosed. With the
27 exception of inboard journal bearing (74) and now outboard ball bearing (72) that support
28 housing (90) and journal stub shaft (60), the remaining elements associated with stub axle
29 (50) are identical to those previously set forth in the description devoted to the embodiment
30 exemplified in Fig. 10.

31 In a similar vein, yet another embodiment of the current invention is portrayed in
32 Fig. 13. As shown, tapered tip (52) of stub axle (50) is operatively interlocked with aperture
33 (94) of conveyor frame (92). Those skilled in the art recognized that the previously set forth
34 embodiments can also operatively interlock with an aperture of a fixed structure in a similar

1 manner. With the exception of inboard ball bearing (76) and now outboard ball bearing (72)
2 that support housing (90) and journal stub shaft (60), the remaining elements associated
3 with stub axle (50) are identical to those previously set forth in the description devoted to
4 the embodiments exemplified in Figs. 10 and 12.

5 Fig. 14 is an inboard end pictorial of an embodiment of incorporating detent (80).
6 Arms (82, 84, 86 and 88) extend inwardly from stub shaft (60) to releasably catch hook (70)
7 of anchor (64). In this specific embodiment, detent (80) is a plastic composition, but those
8 skilled in the art recognize that other compositions can also be utilized, as well as that detent
9 (80) can also be incorporated to other embodiments previously set forth. Because of detent
10 (80), when adequate force is applied to tip (52) of stub axle (50), stub axle (50) can be
11 pulled from stub shaft (60) while stub shaft (60) remains journaled in, for example, ball
12 bearings (76 and 72).

13 Steps associated with the practice of the methods of present invention utilizing select
14 structural elements enabled above are set forth in Figs. 15-19. Having disclosed the
15 invention as required by Title 35 of the United States Code, Applicants now pray
16 respectfully that Letters Patent be granted for their invention in accordance with the scope of
17 the claims appended hereto.

WHAT IS CLAIMED IS:

1
2
3 1) A spring-assisted axially movable electrically conductive axle extending
4 outwardly from a hollow shaft journaled in a bearing for operatively interlocking an aperture
5 of a fixed structure; said spring-assisted axially movable electrically conductive axle,
6 comprising:

7 a) a body engaging said hollow shaft;

8 b) a tip projecting outwardly from said hollow shaft for operatively
9 interlocking with said aperture of said fixed structure, wherein said tip is harder than an
10 exposed surface of said fixed structure circumscribing said aperture; and

11 c) a nonmetallic damper positioned between said tip and said body.

12 2) The invention of claim 1 wherein said tip of said axially movable electrically
13 conductive axle is metal.

14 3) The invention of claim 2 wherein said body of said axially movable
15 electrically conductive axle is metal.

16 4) The invention of claim 2 wherein said body of said axially movable
17 electrically conductive axle is not metal.

18 5) An insertable cartridge coacting with a tube, comprising:

19 a) a housing;

20 b) a first bearing supporting said housing and journaling a stub shaft;

21 c) said stub shaft further including a spring for urging an axially
22 movable electrically conductive axle into an operative interlocking with an aperture of a
23 frame, and

24 d) said axially movable electrically conductive axle further comprising:

25 i) a body engaging said stub shaft;

26 ii) a tip projecting outwardly from said stub shaft for operatively
27 interlocking with said aperture of said frame; and

28 iii) a nonmetallic damper positioned between said tip and said
29 body.

30 6) The invention of claim 5 wherein said tip of said axially movable electrically
31 conductive axle is tapered.

32 7) The invention of claim 6 further comprising a second bearing supporting said
33 housing and journaling said stub shaft.

1 8) The invention of claim 7 wherein said first bearing and said second bearing
2 are ball bearings.

3 9) The invention of claim 8 wherein said tip of said axially movable electrically
4 conductive axle is harder than an exposed surface of said frame's structure circumscribing
5 said aperture.

6 10) The invention of claim 9 further comprising an anchor.

7 11) The invention of claim 10 further comprising a detent for said anchor.

8 12) The invention of claim 11 wherein said tip of said axially movable
9 electrically conductive axle is metal.

10 13) The invention of claim 11 wherein said body of said axially movable
11 electrically conductive axle is metal.

12 14) The invention of claim 11 wherein said body of said axially movable
13 electrically conductive axle is not metal.

14 15) An insertable cartridge coacting with a conveyor roller tube, comprising:

15 a) a housing;

16 b) an inboard bearing supporting said housing and journaling a stub
17 shaft

18 c) an outboard ball bearing supporting said housing and journaling said
19 stub shaft;

20 d) said stub shaft further including a spring for urging an axially
21 movable electrically conductive axle into an operative interlocking with an aperture of a
22 conveyor frame, and

23 e) said axially movable electrically conductive axle further comprising:

24 i) a body engaging said stub shaft;

25 ii) a tapered tip projecting outwardly from said stub shaft for
26 operatively interlocking with said aperture of said frame; and

27 iii) a nonmetallic damper positioned between said tapered tip and
28 said body.

29 16) The invention of claim 15 wherein said tapered tip of said axially movable
30 electrically conductive axle is hexagonal.

31 17) The invention of claim 16 wherein said inboard bearing is a ball bearing.

32 18) The invention of claim 17 wherein said tapered tip of said axially movable
33 electrically conductive axle is harder than an exposed surface of said conveyor's frame
34 circumscribing said aperture.

-15-

- 1 19) The invention of claim 18 further comprising an anchor.
- 2 20) The invention of claim 19 further comprising a detent for said anchor.
- 3 21) The invention of claim 20 wherein said tapered tip of said axially movable
4 electrically conductive axle is metal.
- 5 22) An insertable cartridge coacting with a conveyor roller tube, comprising:
- 6 a) a housing;
- 7 b) an inboard ball bearing supporting said housing and journaling a stub
8 shaft;
- 9 c) an outboard ball bearing supporting said housing and journaling said
10 stub shaft;
- 11 d) said stub shaft further including a chamber having a spring for urging
12 an axially movable electrically conductive axle into an operative interlocking with an
13 aperture of a conveyor frame, and
- 14 e) said axially movable electrically conductive axle further comprising:
- 15 i) a metallic body engaging said electrically conductive
16 nonmetallic stub shaft; and
- 17 ii) a metallic hexagonal tapered tip projecting outwardly from
18 said stub shaft for operatively interlocking with said aperture of said frame, wherein said
19 metallic tapered tip of said axially movable electrically conductive axle is harder than an
20 exposed surface of said conveyor's frame circumscribing said aperture such that said frame
21 rather than said metallic tapered tip encounters wearing from vibrations of said conveyor
22 roller tube.
- 23 23) The invention of claim 22 wherein said metallic body engaging said
24 electrically conductive nonmetallic stub shaft is hexagonal.
- 25 24) The invention of claim 23 further comprising an anchor attached to said
26 axially movable electrically conductive axle.
- 27 25) The invention of claim 24 further comprising a detent for said anchor.
- 28 26) An insertable cartridge coacting with a conveyor roller tube, comprising:
- 29 a) a housing;
- 30 b) an inboard ball bearing supporting said housing and journaling a stub
31 shaft
- 32 c) an outboard ball bearing supporting said housing and journaling said
33 stub shaft;

-16-

1 d) said stub shaft further including a spring for urging a hexagonal
2 axially movable electrically conductive axle into an operative interlocking with an aperture
3 of a conveyor frame, and

4 e) said hexagonal axially movable electrically conductive axle further
5 comprising:

6 i) a body engaging said stub shaft;

7 ii) a metallic tapered tip projecting outwardly from said stub
8 shaft for operatively interlocking with said aperture of said frame, wherein said metallic
9 tapered tip is harder than an exposed surface of said conveyor's frame circumscribing said
10 aperture; and

11 iii) a nonmetallic damper positioned between said tapered tip and
12 said body.

13 27) The invention of claim 26 further comprising an anchor attached to said
14 hexagonal axially movable electrically conductive axle.

15 28) The invention of claim 27 further comprising a detent for said anchor.

16 29) The invention of claim 28 wherein said body of said hexagonal axially
17 movable electrically conductive axle is not metal and is softer than said metallic tapered tip
18 of said hexagonal axially movable electrically conductive axle.

19 30) A method of operatively interlocking a tip of an electrically conductive axle
20 to an aperture of a conveyor frame for reducing vibration and noise of a conveyor roller,
21 comprising the steps of:

22 a) inserting a cartridge including a ball bearing into an end of a
23 conveyor roller;

24 b) supporting said cartridge from said ball bearing;

25 c) journaling a stub shaft in said ball bearing;

26 d) loading a spring into said stub shaft for urging said electrically
27 conductive axle body toward said aperture of said conveyor frame;

28 e) incorporating a tip on said electrically conductive axle body, wherein
29 said tip is harder than an exposed surface of said conveyor's frame circumscribing said
30 aperture;

31 f) positioning a damper between said tip and said electrically conductive
32 axle body; and

33 g) operatively interlocking said tip of said electrically conductive axle
34 body with said aperture.

-17-

1 31) The method of claim 30 further comprising the step of releasably anchoring
2 said electrically conductive axle body to said stub shaft.

3 32) The method of claim 31 further comprising the step of including a second
4 ball bearing in said cartridge.

5 33) The method of claim 32 further comprising the step of tapering said tip.

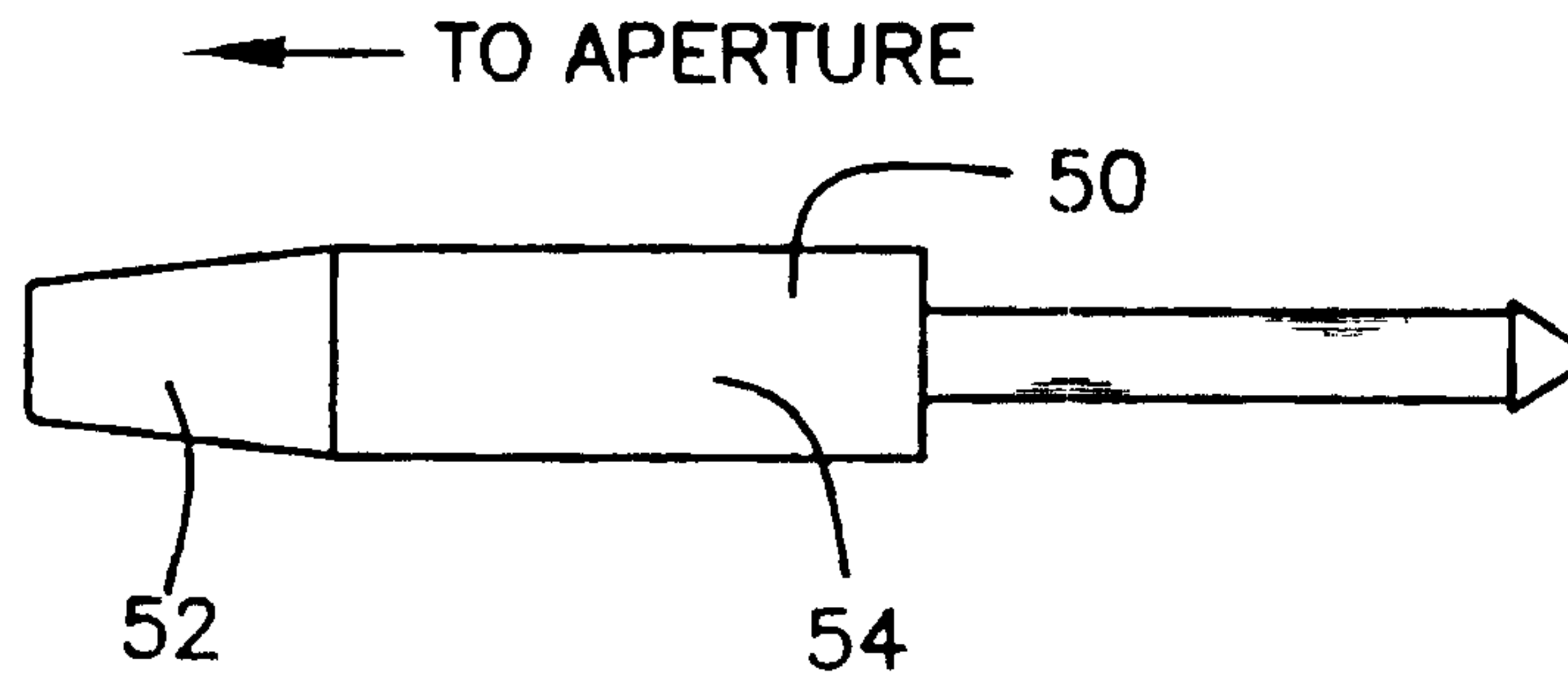

FIG. 1

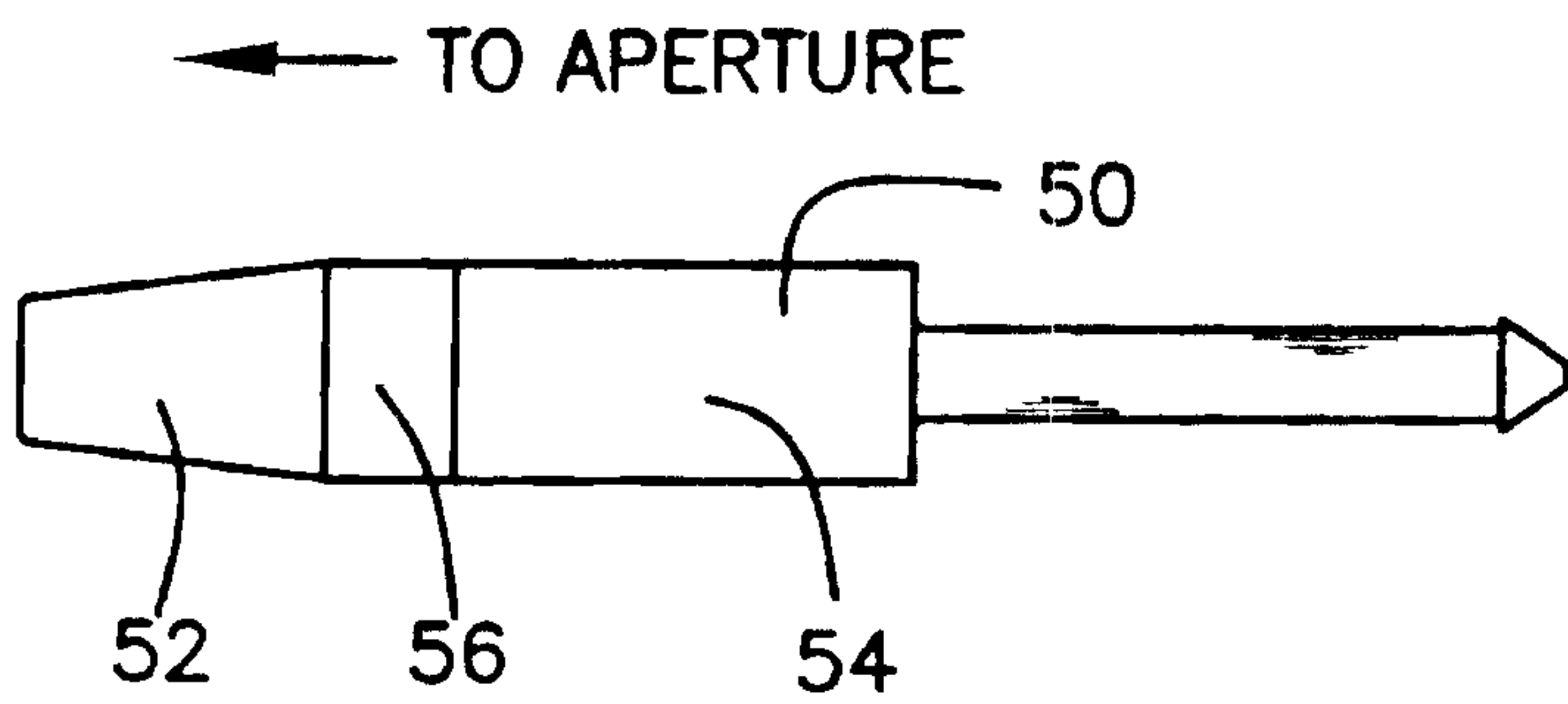

FIG. 2

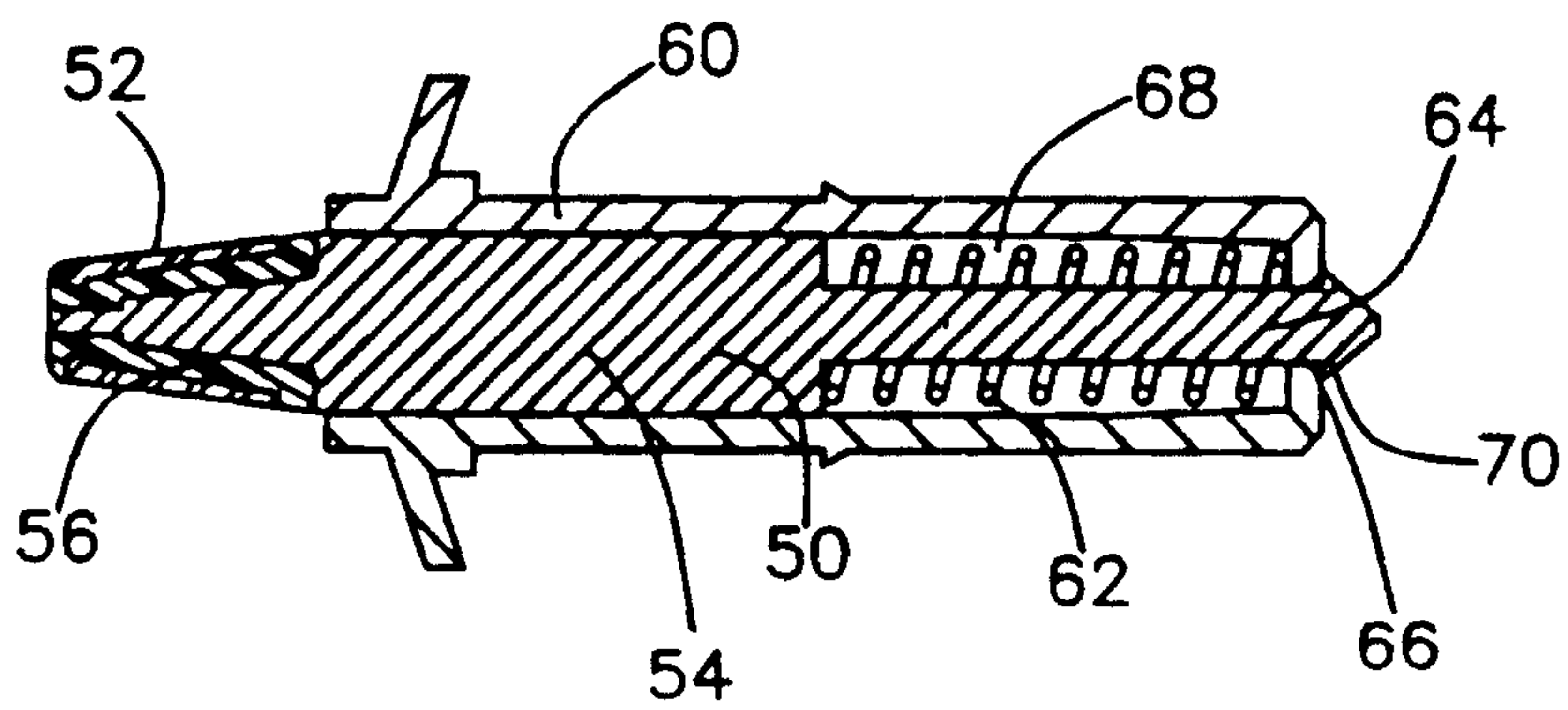

FIG. 3

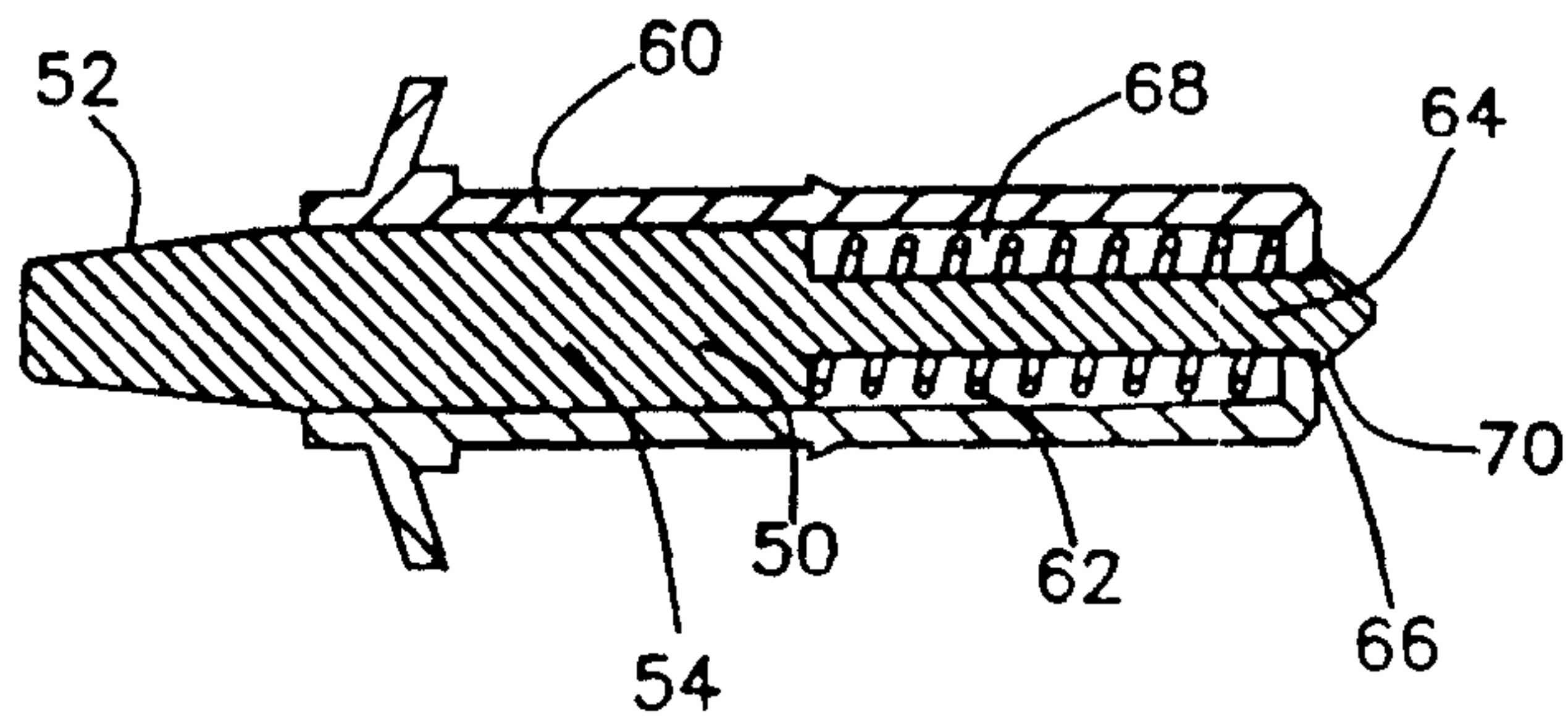

FIG. 4

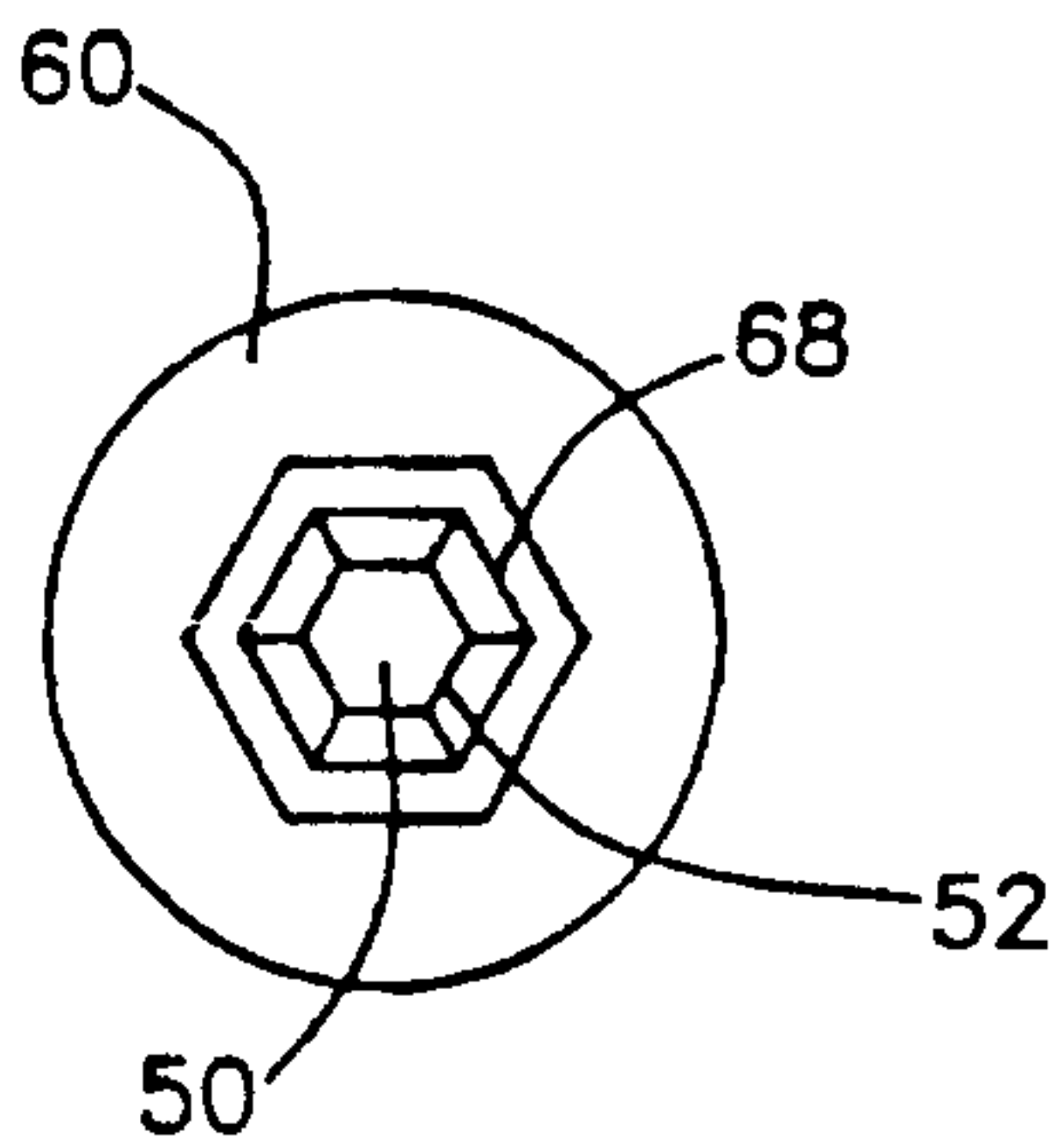

FIG. 5

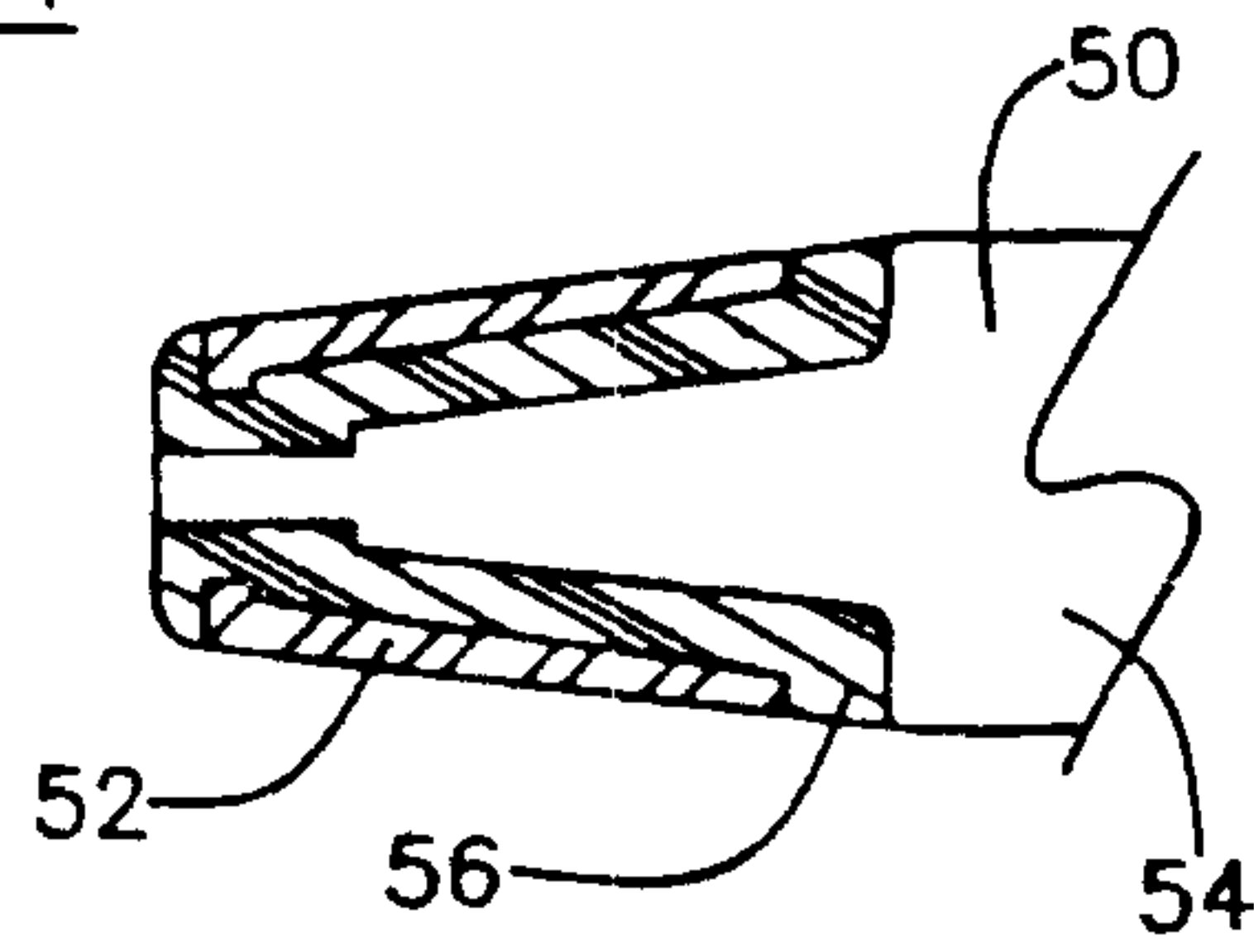

FIG. 6

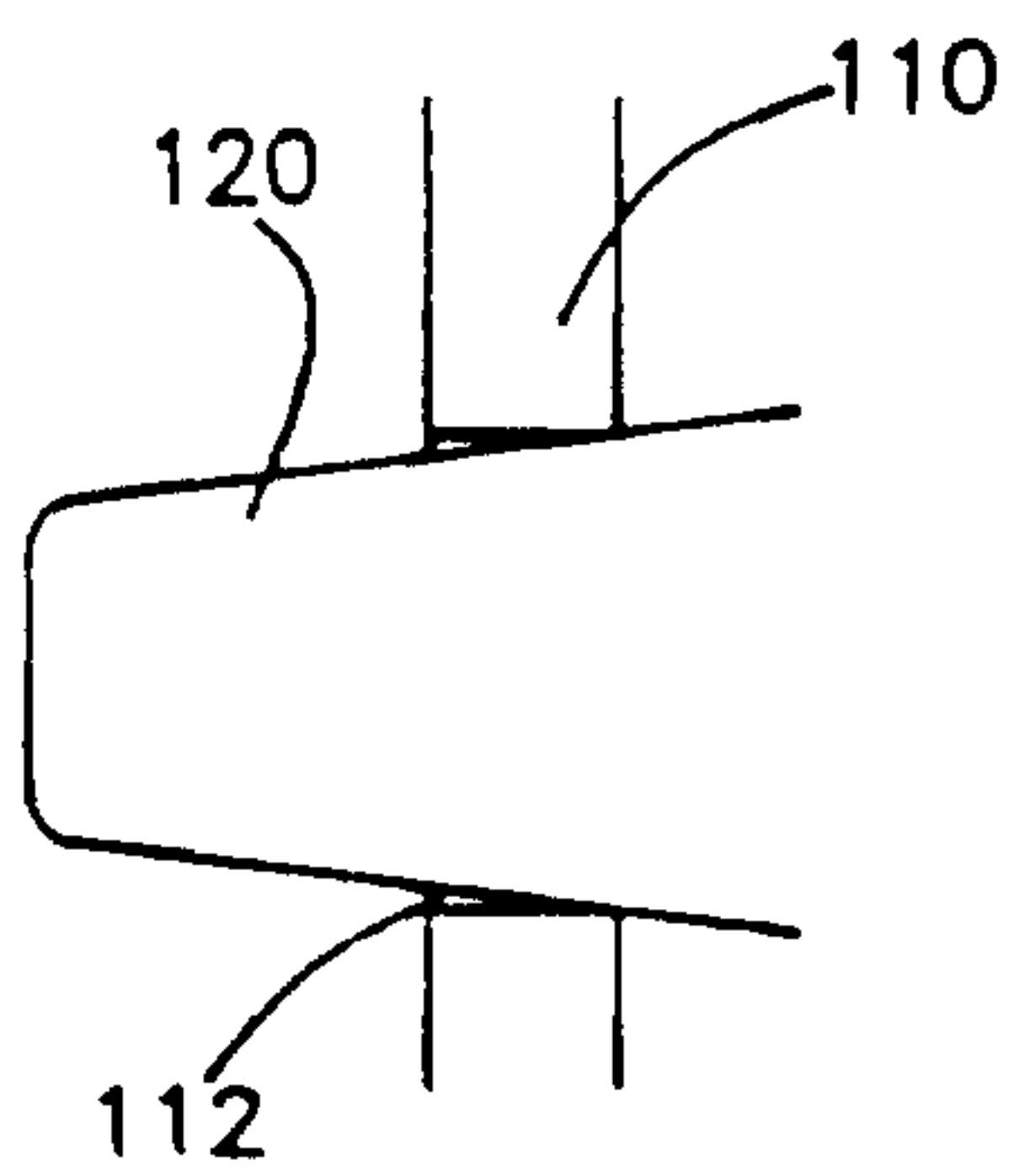

FIG. 7

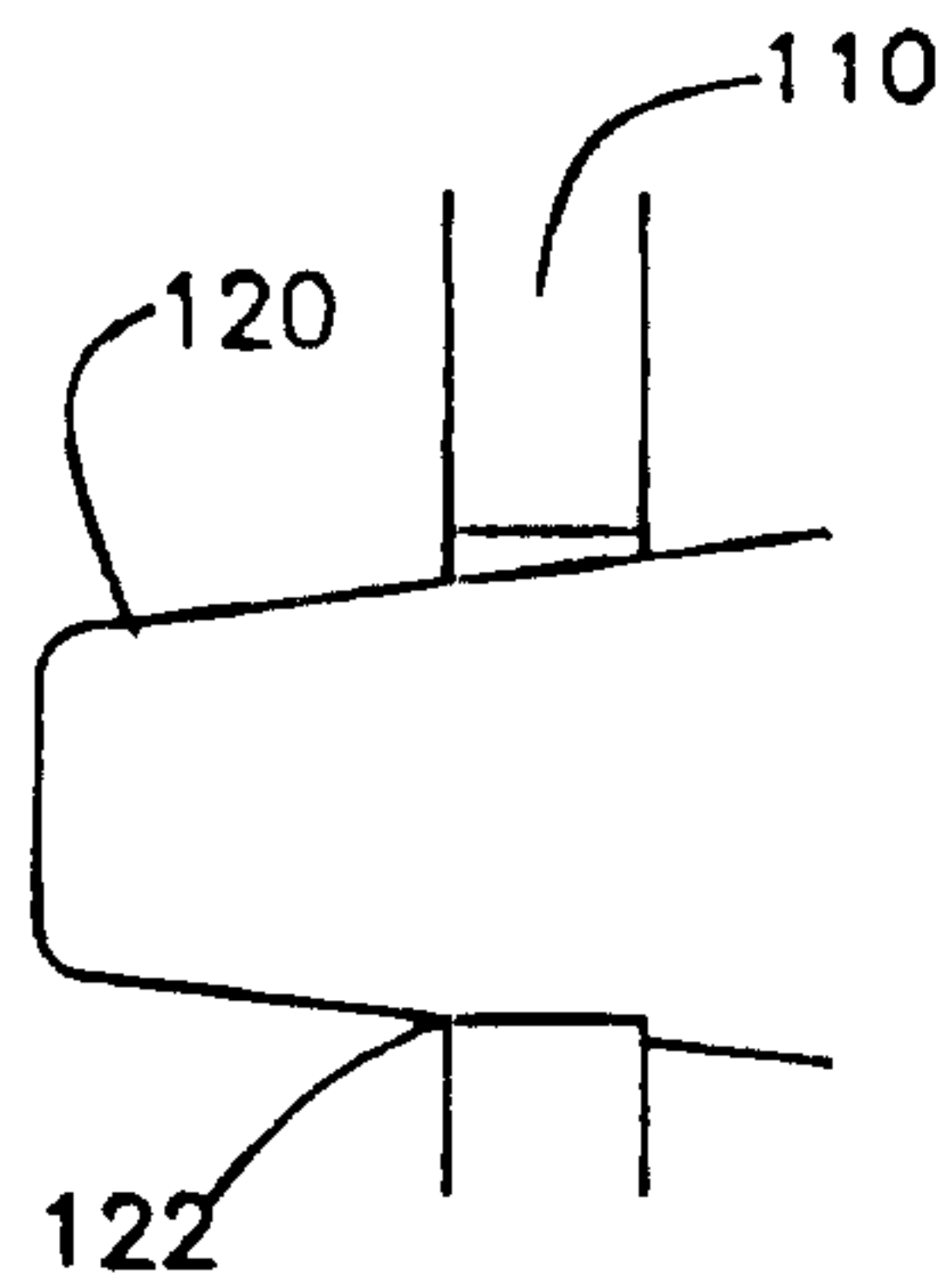

FIG. 8

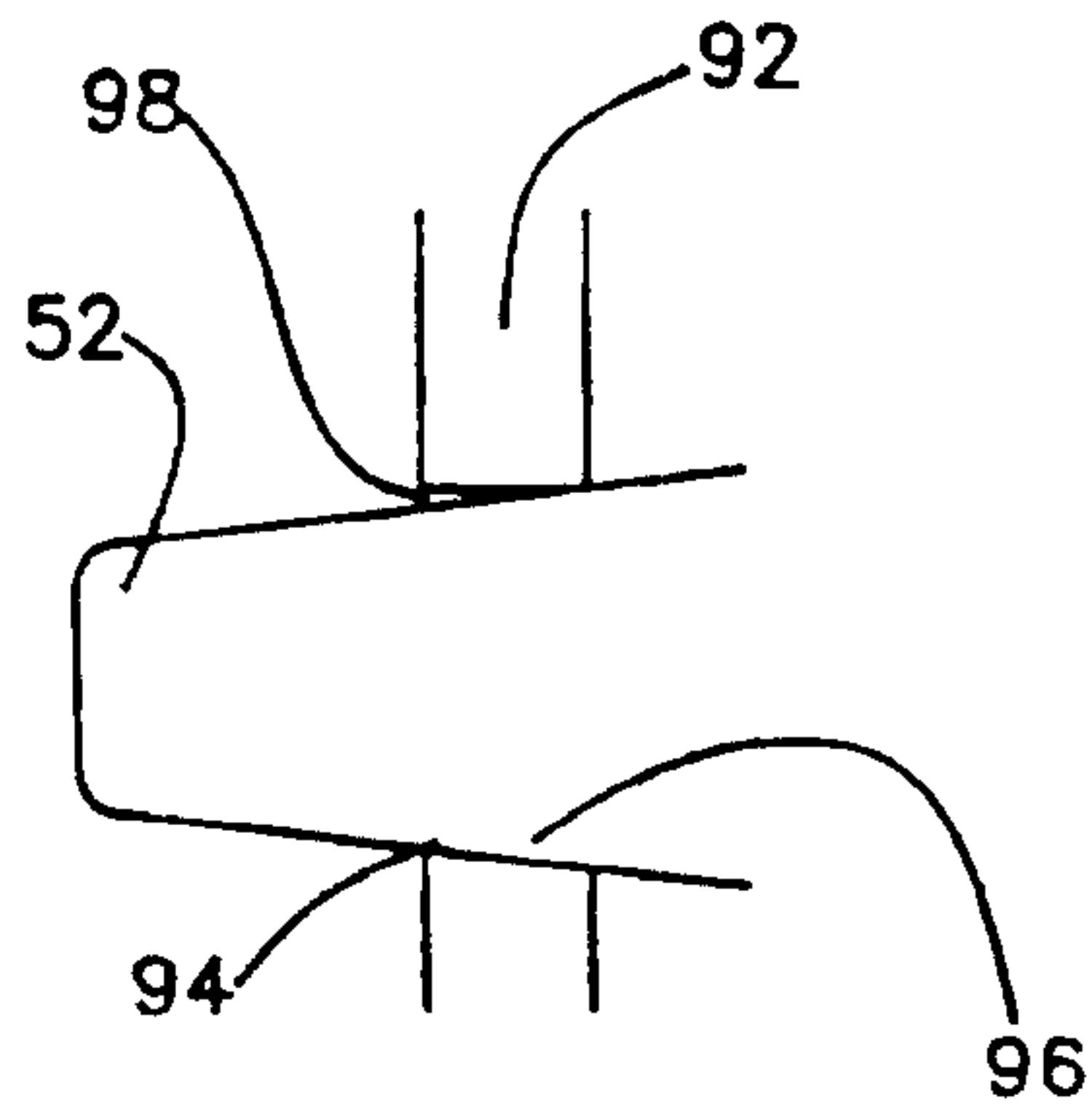

FIG. 9

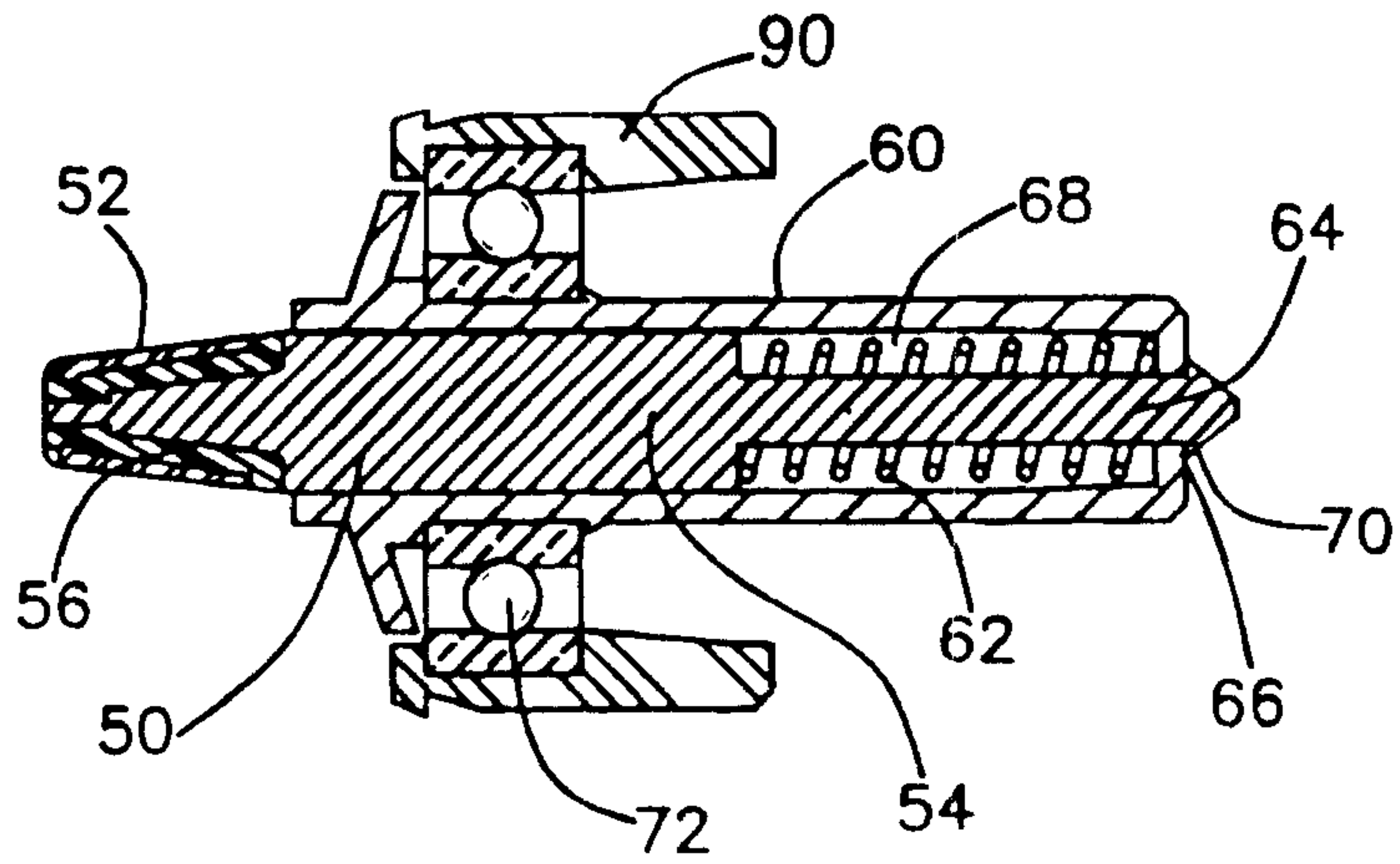

FIG. 10

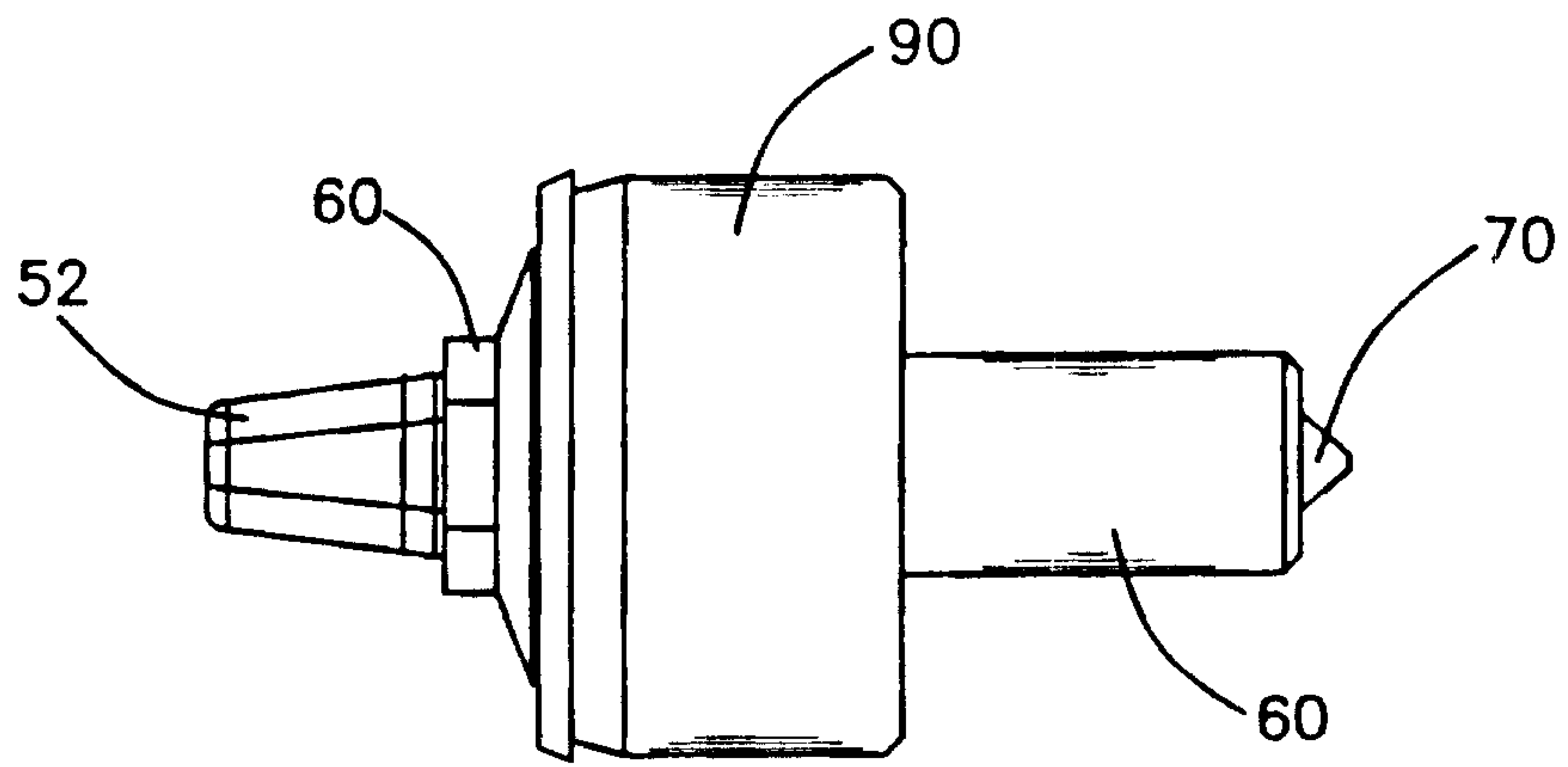

FIG. 11

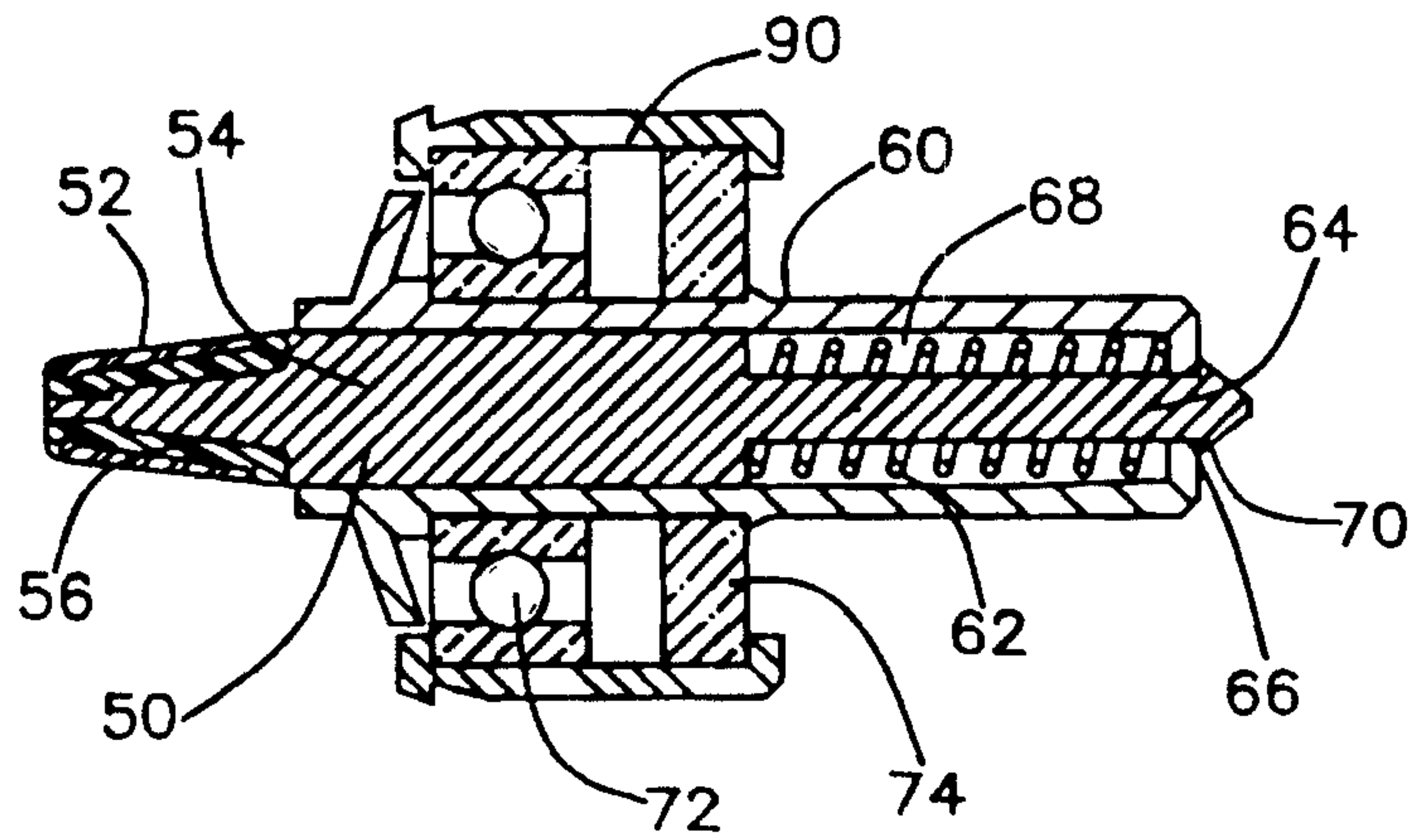

FIG. 12

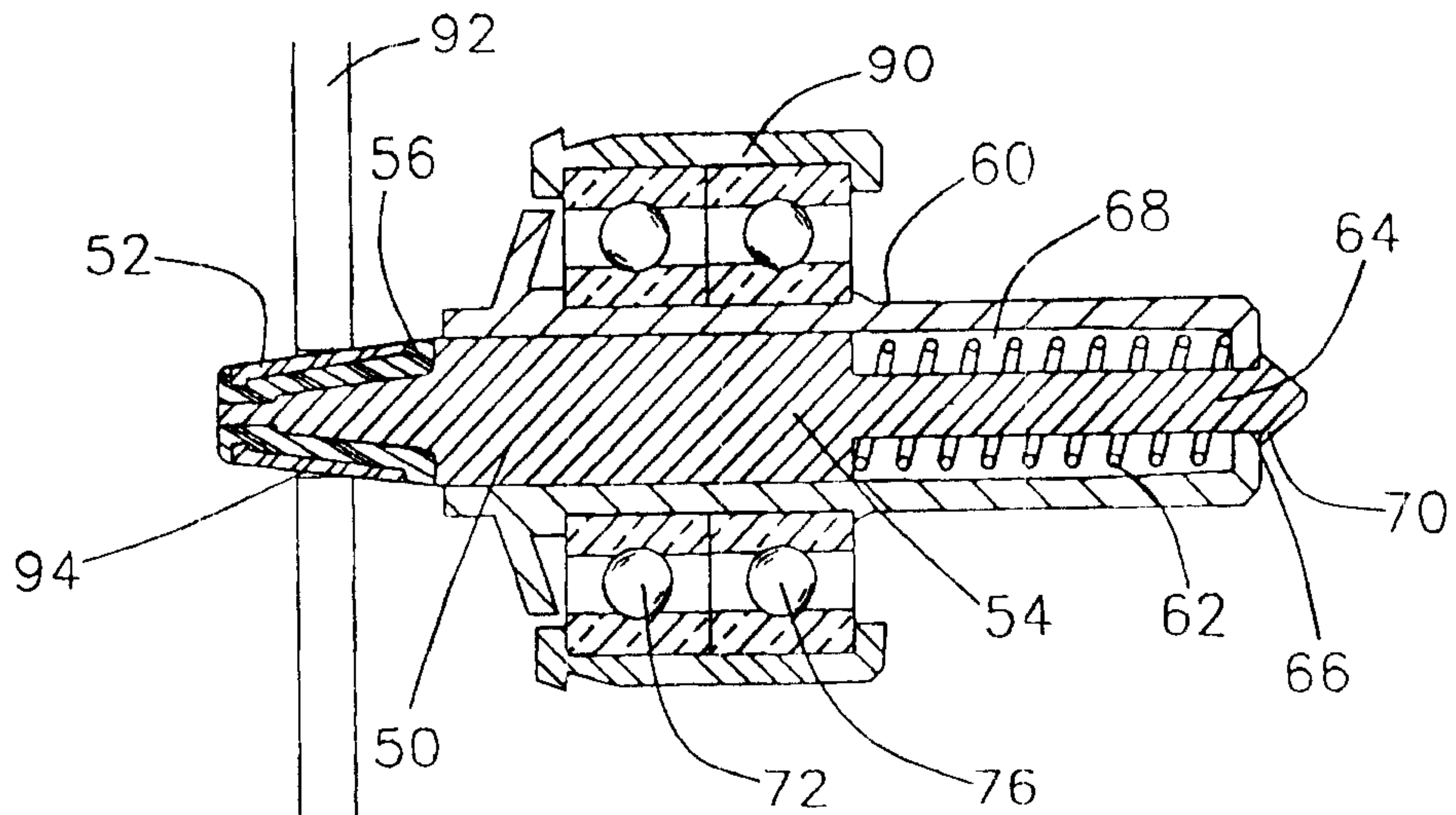

FIG. 13

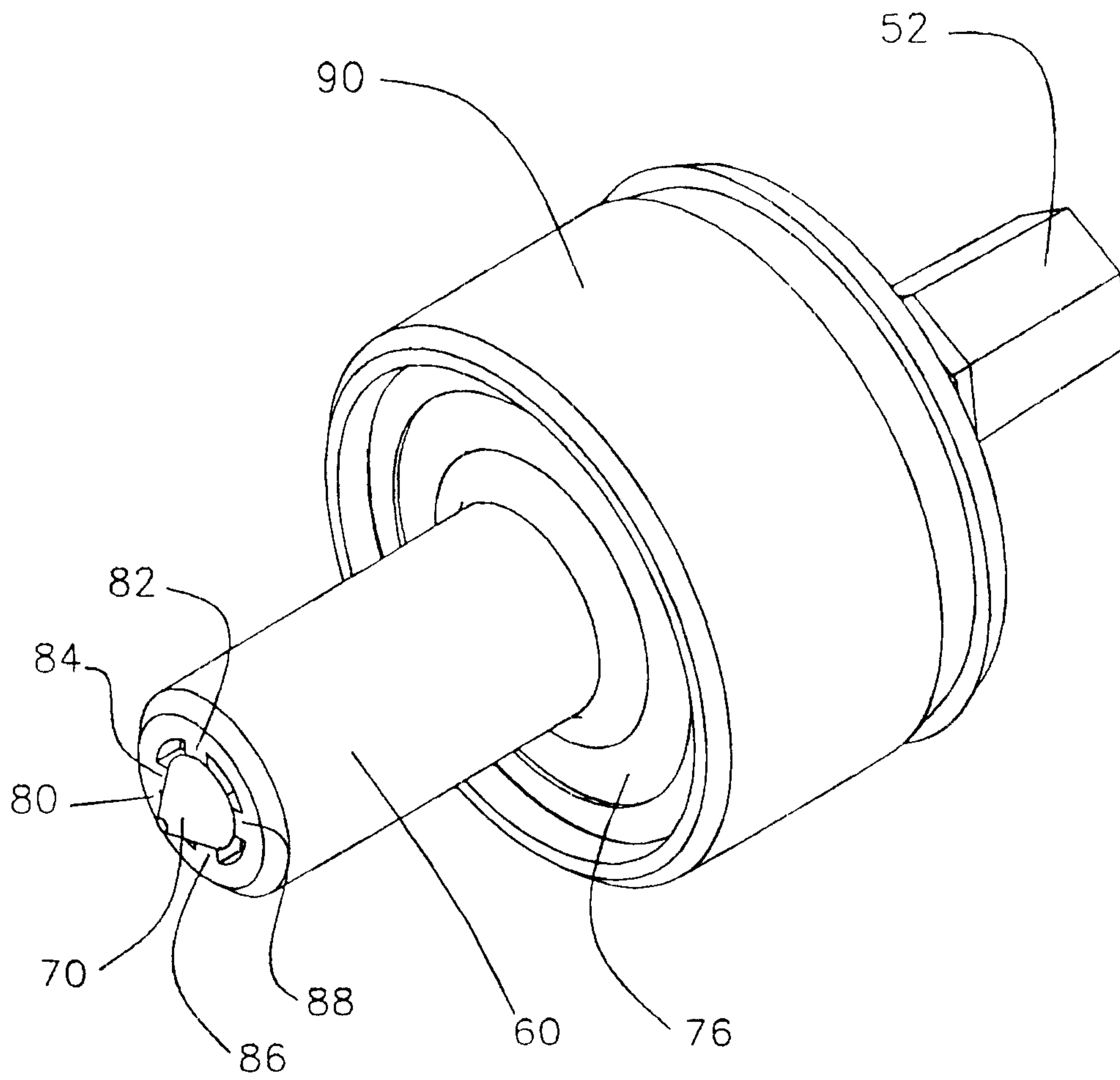

FIG. 14

FIG 15

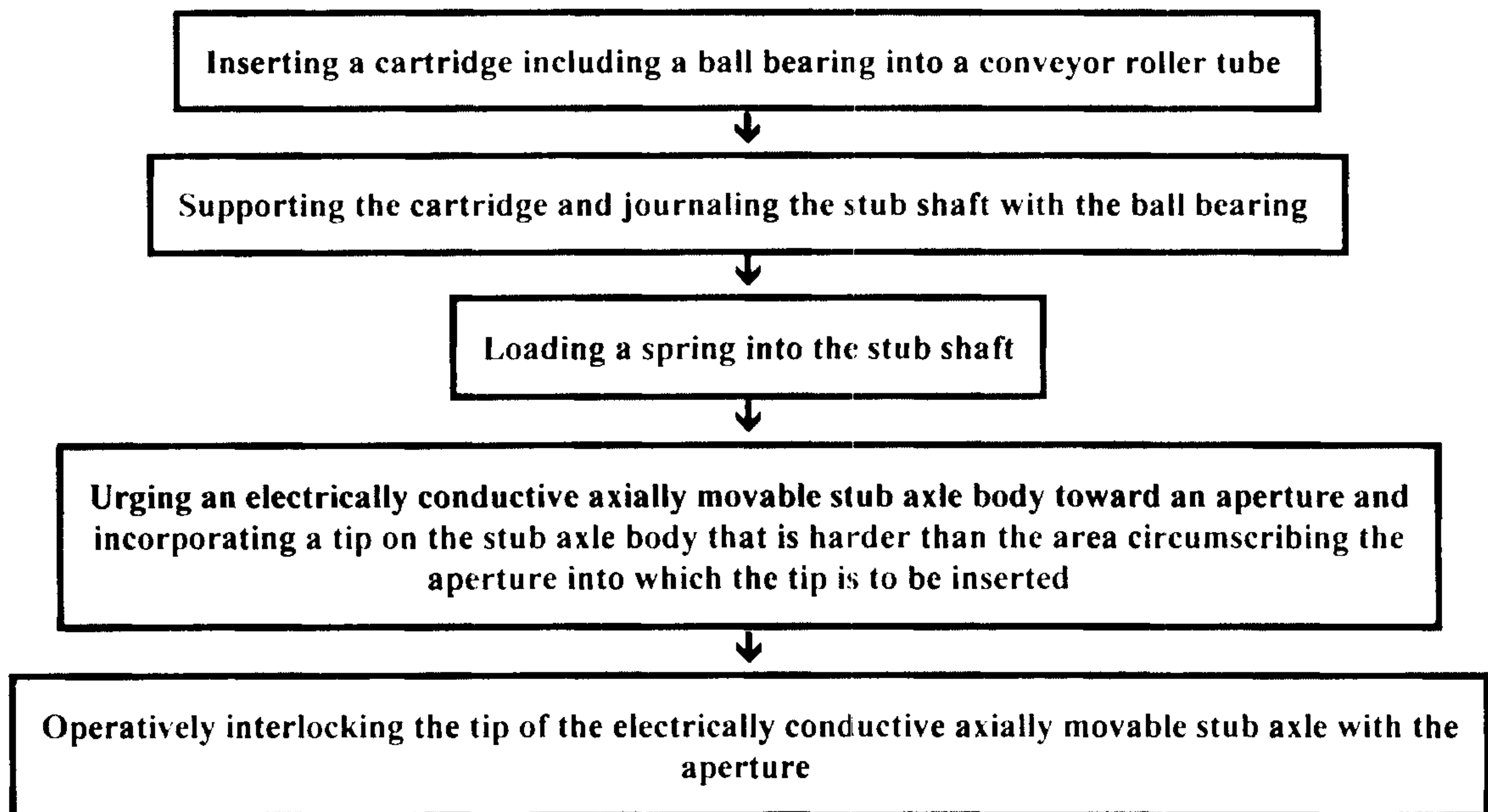

FIG 16

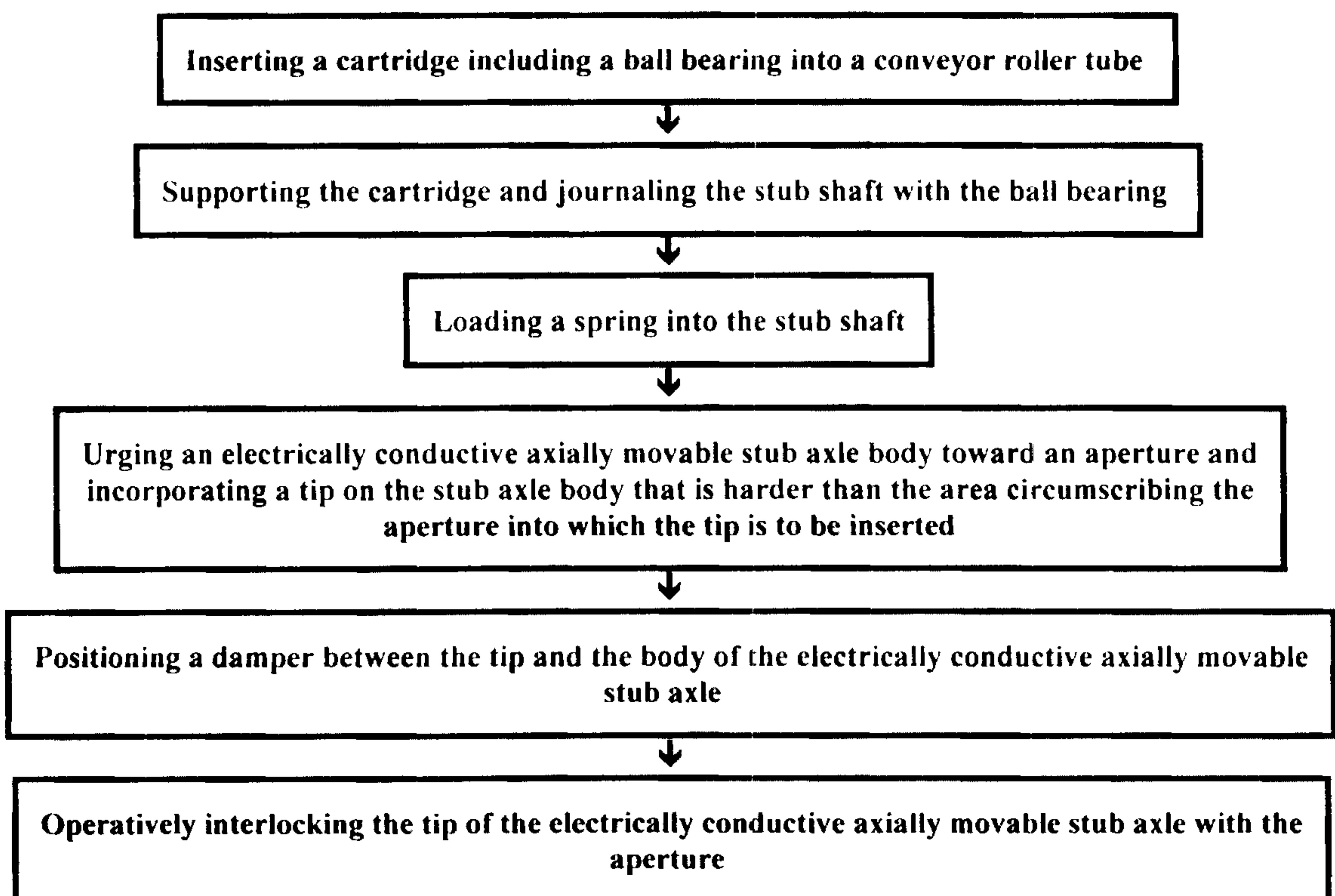

FIG 17

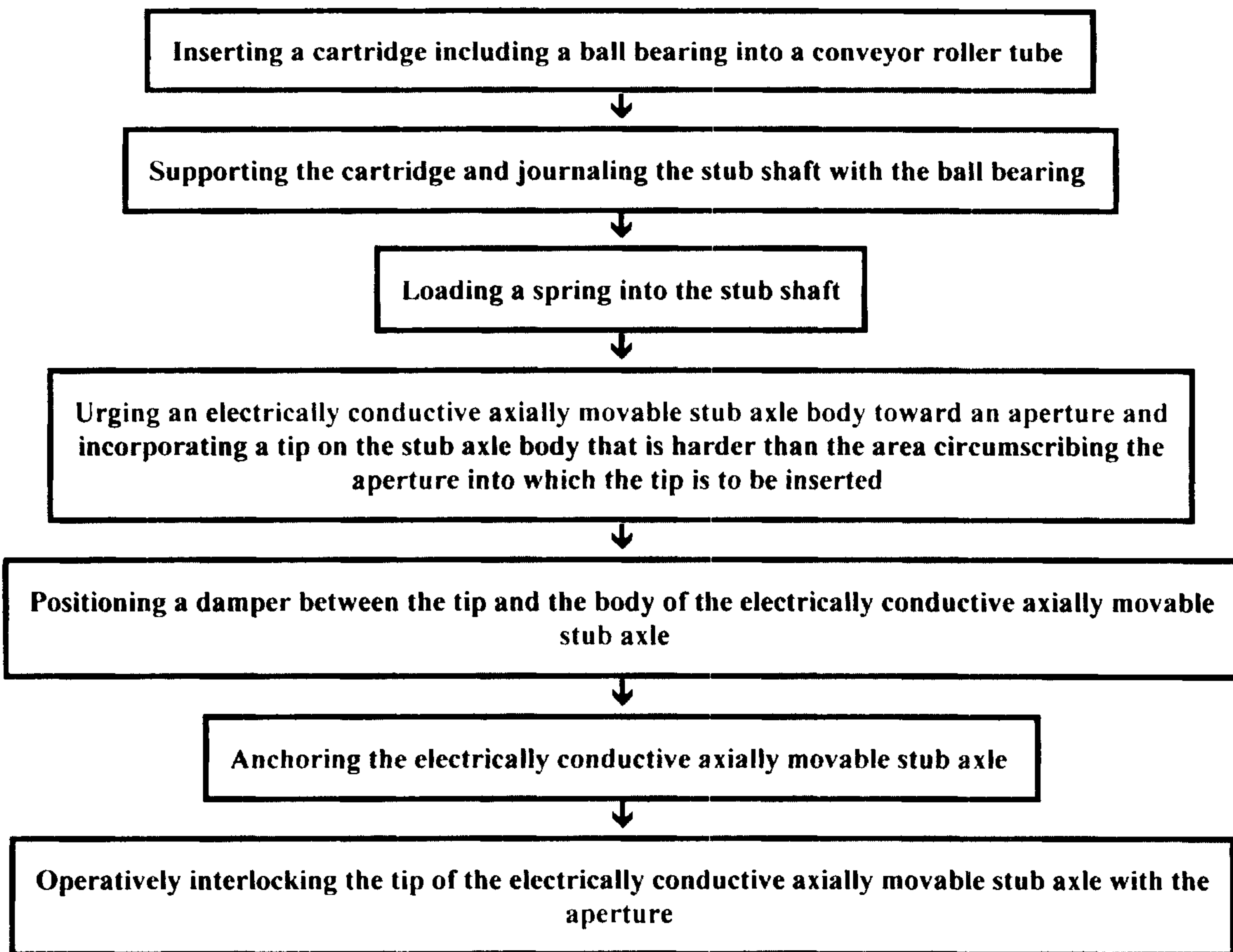

FIG 18

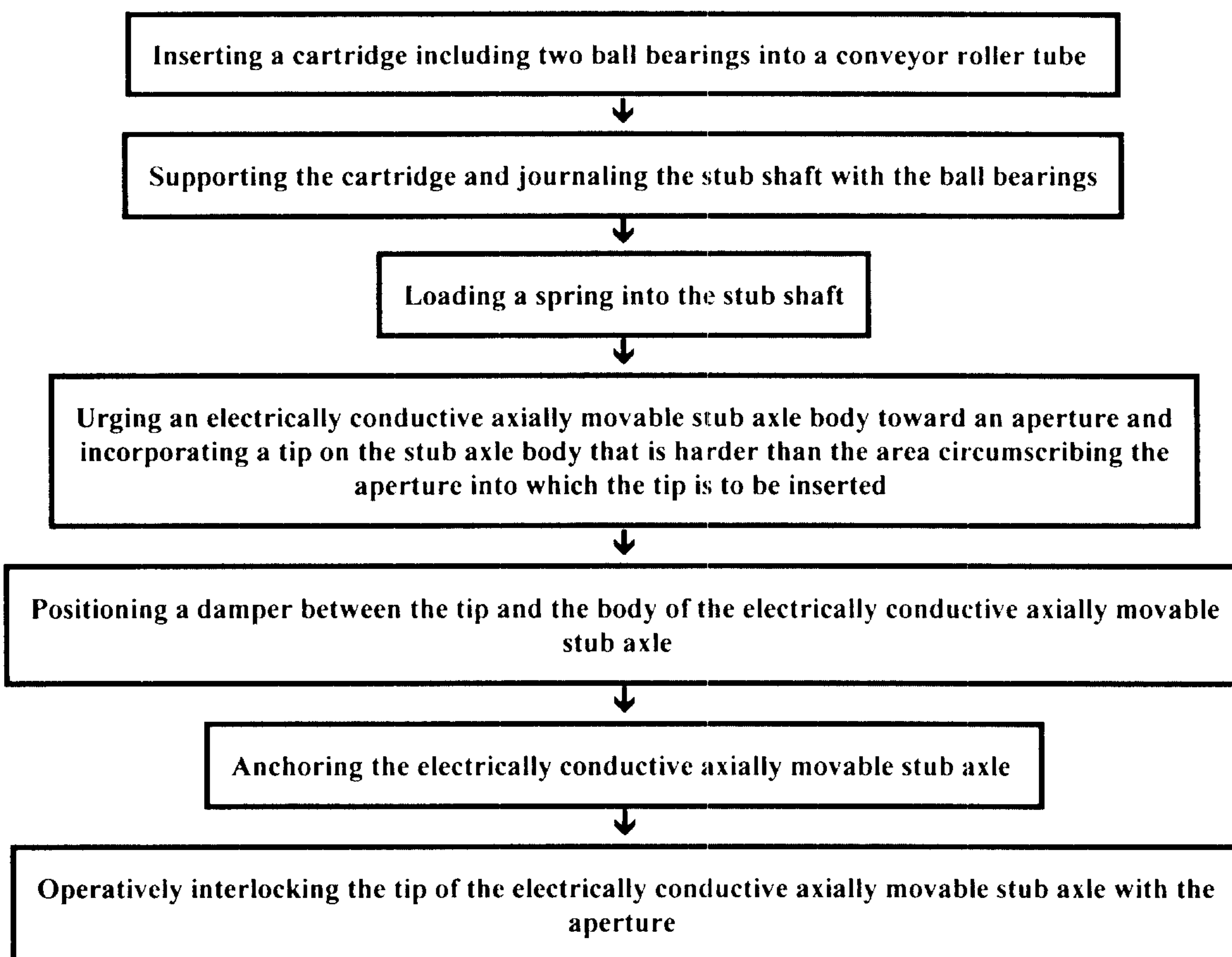
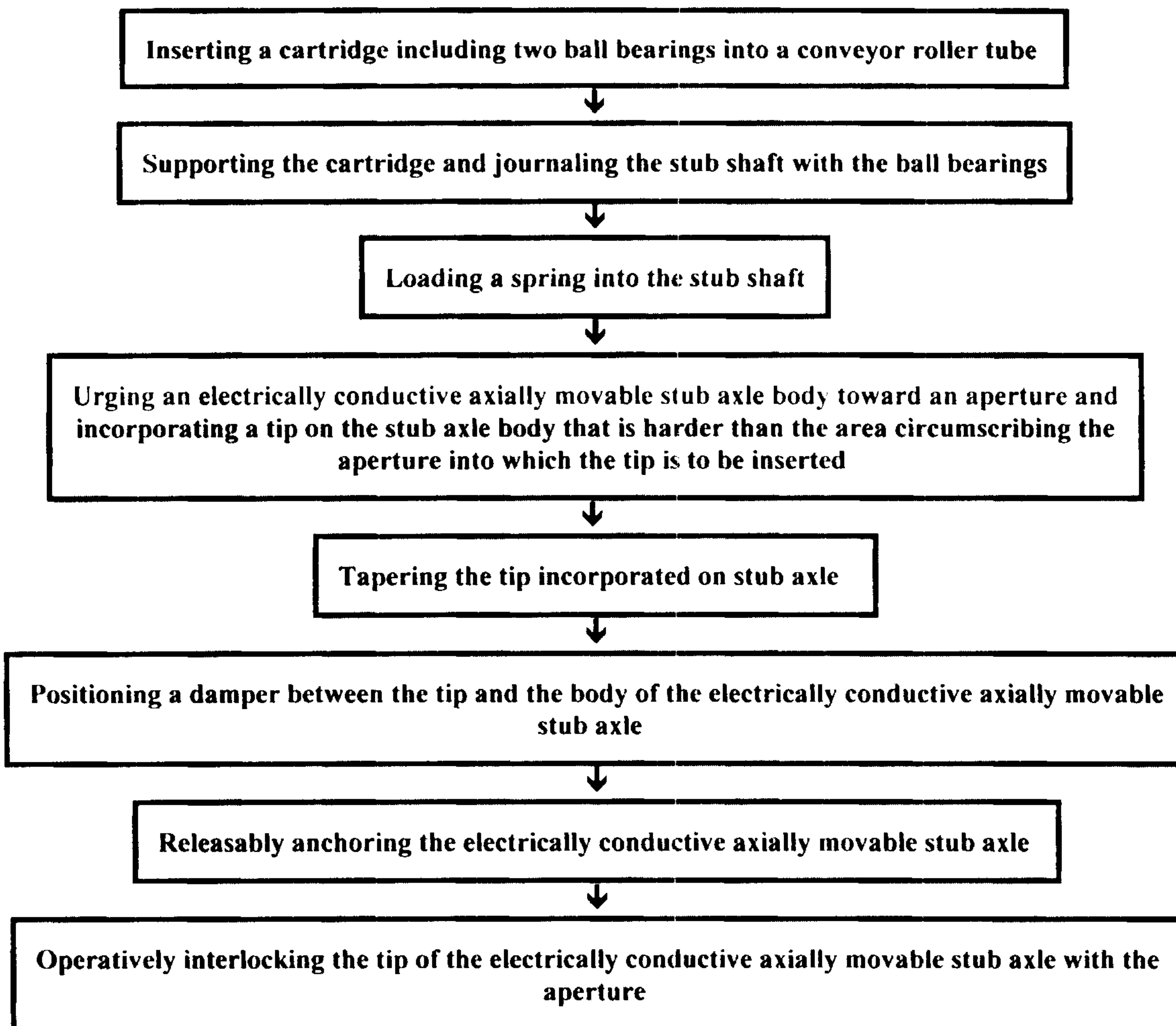

FIG 19



← TO APERTURE

