

(No Model.)

R. M. DUNN.

DISCHARGE VALVE FOR OIL WELL STAND PIPES.

No. 397,115.

Patented Feb. 5, 1889.

Fig. 1.

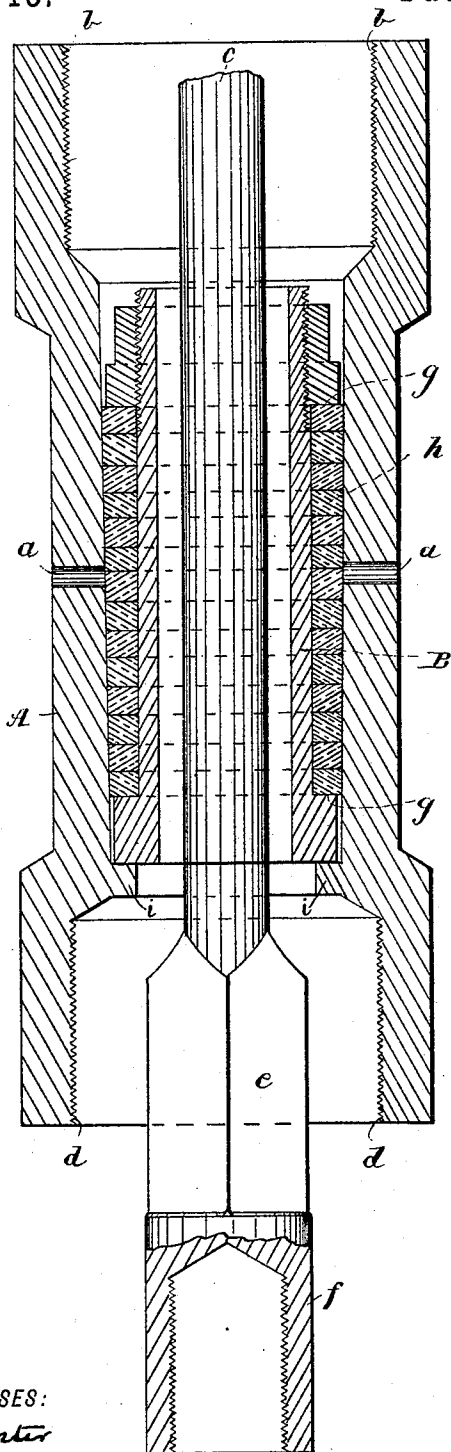

Fig. 2.

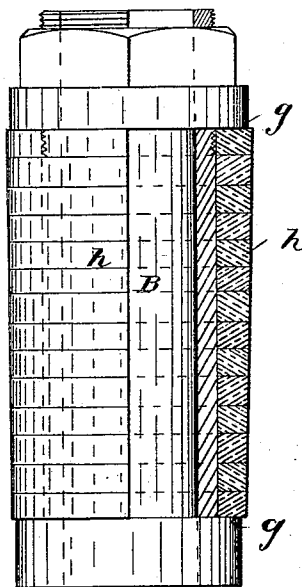
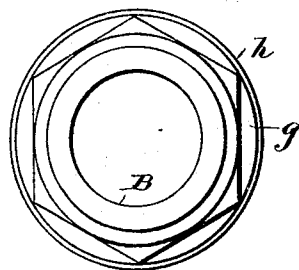

Fig. 3.



WITNESSES:
Ernest Kaester
S. A. Shipple

INVENTOR.
R. M. Dunn

UNITED STATES PATENT OFFICE.

ROBERT M. DUNN, OF REW, PENNSYLVANIA.

DISCHARGE-VALVE FOR OIL-WELL STAND-PIPES.

SPECIFICATION forming part of Letters Patent No. 397,115, dated February 5, 1889.

Application filed August 15, 1887. Serial No. 247,035. (No model.)

To all whom it may concern:

Be it known that I, ROBERT M. DUNN, of the village of Rew, in the county of McKean and State of Pennsylvania, have invented a new and Improved Discharge-Valve for Oil-Well Stand-Pipes; and I do hereby declare that the following is a full and exact description thereof, reference being had to the accompanying drawings, and to the letters of reference marked thereon.

In the accompanying drawings, illustrating my invention, in which similar letters of reference denote corresponding parts, Figure 1 is a sectional side elevation of a portion of a well-tubing with my valve and its valve-rod situated in position therein. Fig. 2 is a detail representation of the valve, one-half being shown in section. Fig. 3 is a top plan view of the same.

It has been found in practice that a large quantity of oil is daily lost owing to the fact that the tubing becomes filled with oil, and when the working parts are lifted up out of the tubing it raises the oil with them, causing it to overflow the tubing and be wasted, beside messing the floor of the oil-house. It is also a well-known fact that the oil fills and accumulates in the tubing, and when the valve-rods and valves were inserted they would float upon the oil for a considerable period before sinking to the bottom of the well, owing to the density of the oil, creating a great loss of time to the oil-men.

The object of my invention is to construct a device which shall be simple in construction, inexpensive in manufacture, and efficient in operation, and which will obviate these and other disadvantages found to exist in oil-wells.

To these ends my invention consists in constructing the well-tubing with perforations for the escape of this accumulated oil, adapted to be opened or closed by a valve or plug.

My invention further consists in providing a valve-rod with an enlargement at the lower extremity adapted to engage with the said plug or valve in such a manner that the plug or valve will be raised by the lifting of the valve-rod in order to uncover the said perforations to permit the oil to escape.

My invention further consists in certain pe-

culiarities in the construction, arrangement, and combination of parts, substantially as will be hereinafter described, and particularly pointed out in the claim at the end of the specification.

Referring to the drawings, A represents a tubing or casting adapted to be secured to the bottom of a well-tubing and to the mouth of the working barrel, preferably by means of the screw-threads *b b* and *d d*, respectively. This casting A receives a closely-fitting hollow plug or valve, B, seated upon flanges *i*, formed on the interior of the said casting, and is formed with perforations or apertures *a a*, adapted to be opened by the said plug or valve B, to permit the escape of the oil which has accumulated in the tubing, and to be closed by the same when the well is in operation.

The plug or valve B is operated by a valve rod or stem, *c*, the lower extremity of which is formed with an enlargement, *e*, of any suitable construction, and carries the ordinary plunger-cup, *f*. The valve rod or stem *c* is made of a much smaller diameter than the valve or plug B, in order to permit the oil to flow up and out through the tubing and through the said valve around the valve-stem.

The plug or valve B is preferably formed at either extremity with flanges *g g*, between which a packing, *h*, is adapted to be situated, and prevents the escape of any fluid on the outer side of the said plug or valve. I have herein shown this packing as consisting of a series of washers formed of leather, vulcanized rubber, or any other suitable material; but I do not wish to be understood as limiting myself to this particular construction of packing, as any other suitable packing might be adopted, if desired, without departing from the spirit of my invention.

From the foregoing the operation of my device will be readily comprehended.

When the oil in the well is flowing or being pumped out through the tubing A, the valve B is situated in its normal position, (shown in Fig. 1,) and rests against the wall of the tubing, closing the perforations *a a* and preventing the escape of the oil through them. When the pumping is concluded and it is desired to permit the oil which has accumulated in the tubing to escape, it will be obvious that

by raising the valve rod or stem a sufficient distance its enlargement will abut against the bottom of the valve or plug, and by raising it farther the said valve will be lifted past the perforations in the casting and the accumulated oil will escape through them and flow back into the well, instead of being lifted out with the said valve and stem and overflowing the tubing and being wasted, causing a consequent loss to the owners of the well and messing the floor of the oil-house. It will be evident, also, that by constructing the casting with these perforations for the escape of the accumulated oil the tubing will at all times be kept clean and free from oil, and there is no liability of the pumping-rods having to float upon any accumulated oil for an uncertain period before reaching the bottom; but it will descend immediately to the bottom of the well, and the apparatus will be in condition to work.

Having now described the objects, construction, and advantages of my invention, and having set forth a preferred means of carrying the same into practice, what I believe to be new, and desire to secure by Letters Patent, and what I therefore claim, is—

A straight-sided valve-casing having a uniform inner diameter and having an outlet and an internal shoulder formed thereon, in combination with a hollow movable plug or valve which fits within said cylinder and is adapted to rest on said internal shoulder in the cylinder, and a piston-rod which operates said plug, substantially as and for the purposes specified.

ROBERT M. DUNN.

Witnesses:

ERNEST KAESTER,
S. H. WHIPPLE.