

(12) **United States Patent**
Sakai et al.

(10) **Patent No.:** **US 10,807,552 B2**
(45) **Date of Patent:** **Oct. 20, 2020**

(54) **VEHICLE SEAT DEVICE**
(71) Applicants: **AISIN SEIKI KABUSHIKI KAISHA**, Kariya-shi (JP); **TOYOTA JIDOSHA KABUSHIKI KAISHA**, Toyota-shi (JP)
(72) Inventors: **Makoto Sakai**, Anjo (JP); **Ryosuke Mizuno**, Toyota (JP); **Tomokazu Seki**, Kariya (JP); **Katsuya Nozue**, Toyohashi (JP); **Shunsuke Tanaka**, Nisshin (JP); **Kenji Hashimoto**, Nisshin (JP)
(73) Assignees: **AISIN SEIKI KABUSHIKI KAISHA**, Kariya-shi (JP); **TOYOTA JIDOSHA KABUSHIKI KAISHA**, Toyota-shi (JP)
(*) Notice: Subject to any disclaimer, the term of this patent is extended or adjusted under 35 U.S.C. 154(b) by 99 days.

(21) Appl. No.: **16/325,202**
(22) PCT Filed: **Aug. 8, 2017**
(86) PCT No.: **PCT/JP2017/028746**
§ 371 (c)(1),
(2) Date: **Feb. 13, 2019**
(87) PCT Pub. No.: **WO2018/037909**
PCT Pub. Date: **Mar. 1, 2018**
(65) **Prior Publication Data**
US 2019/0193663 A1 Jun. 27, 2019

(30) **Foreign Application Priority Data**
Aug. 24, 2016 (JP) 2016-163308

(51) **Int. Cl.**
B60R 21/215 (2011.01)
B60N 2/64 (2006.01)
(Continued)

(52) **U.S. Cl.**
CPC **B60R 21/215** (2013.01); **B60N 2/427** (2013.01); **B60N 2/64** (2013.01); **B60N 2/68** (2013.01);
(Continued)

(58) **Field of Classification Search**
CPC B60R 21/215; B60R 21/207; B60R 2021/161; B60N 2/64; B60N 2/68; B60N 2/427
(Continued)

(56) **References Cited**
U.S. PATENT DOCUMENTS
6,129,419 A * 10/2000 Neale B60N 2/58 297/284.4
9,358,909 B2 * 6/2016 Jeong B60N 2/99
(Continued)

FOREIGN PATENT DOCUMENTS
JP 2014-151822 A 8/2014

OTHER PUBLICATIONS
International Search Report dated Oct. 3, 2017 in PCT/JP2017/028746 filed on Aug. 8, 2017.

Primary Examiner — Paul N Dickson
Assistant Examiner — Kurtis Nielson
(74) *Attorney, Agent, or Firm* — Oblon, McClelland, Maier & Neustadt, L.L.P.

(57) **ABSTRACT**
A vehicle seat device includes a fixed base, a movable base, a paddle, and an air pack. When a side airbag arranged in the seat is deployed, the expanding side airbag presses and pivots the movable base and allows for a deployment of the side airbag. The paddle is configured to change a seat support form when pressed and pivoted by the air pack. The movable base pivots about a first pivot axis relative to the fixed base. The paddle pivots about a second pivot axis relative to the movable base. The first pivot axis and the second pivot axis are arranged at different locations.

5 Claims, 9 Drawing Sheets

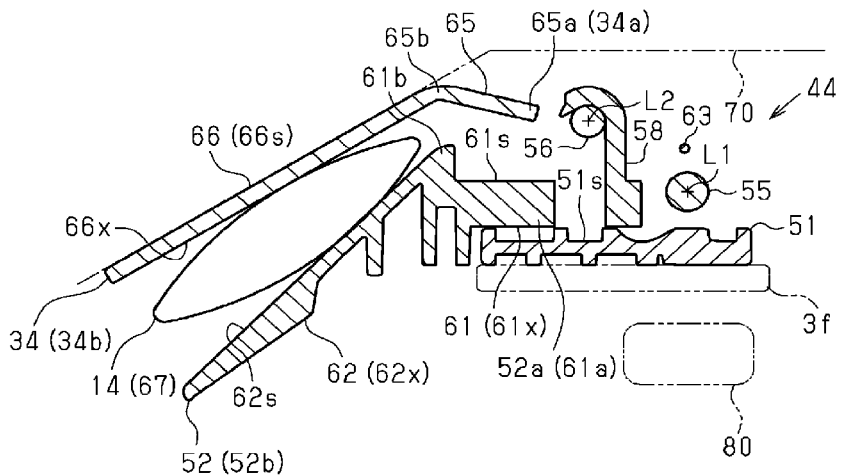

- (51) **Int. Cl.**
B60N 2/68 (2006.01)
B60N 2/427 (2006.01)
B60R 21/207 (2006.01)
B60R 21/16 (2006.01)
- (52) **U.S. Cl.**
CPC *B60R 21/207* (2013.01); *B60R 2021/161*
(2013.01)
- (58) **Field of Classification Search**
USPC 280/728.3
See application file for complete search history.

(56) **References Cited**

U.S. PATENT DOCUMENTS

9,896,007	B2 *	2/2018	Ohno	B60N 2/885
10,272,866	B2 *	4/2019	Hiraiwa	B60N 2/99
2008/0136237	A1 *	6/2008	Kayumi	B60N 2/914
					297/284.9
2012/0043791	A1 *	2/2012	Kojima	B60R 21/207
					297/216.13
2013/0169010	A1 *	7/2013	Sugiyama	B60N 2/42745
					297/216.13
2015/0360636	A1	12/2015	Kaneko et al.		
2016/0152203	A1 *	6/2016	Wiegelmann	B60N 2/58
					280/730.2
2019/0023217	A1 *	1/2019	Ohno	B60R 21/233

* cited by examiner

Fig. 1

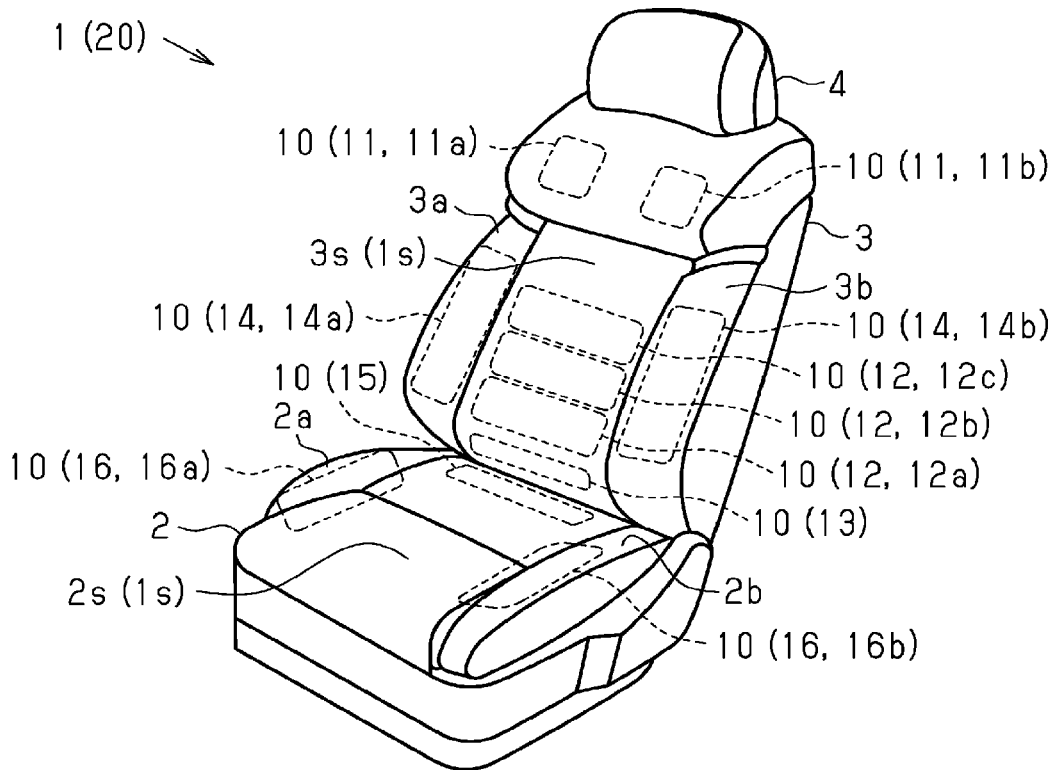

Fig. 2

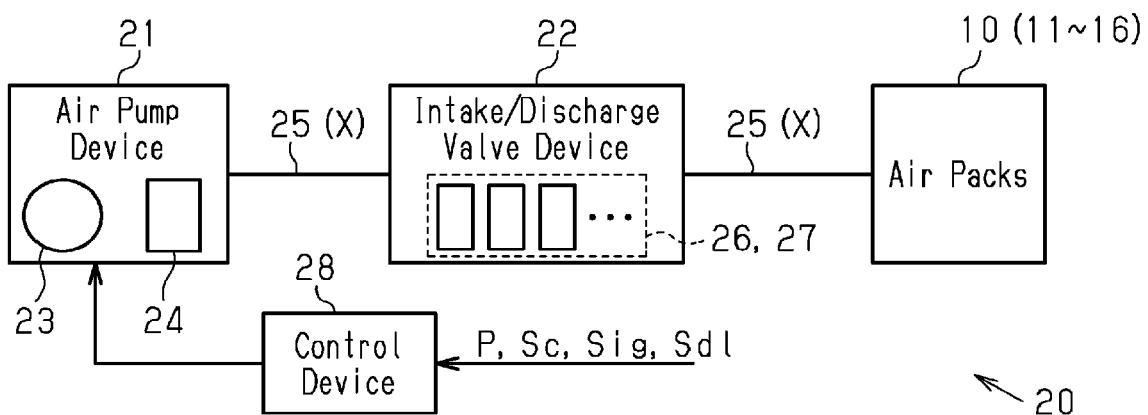

Fig. 3

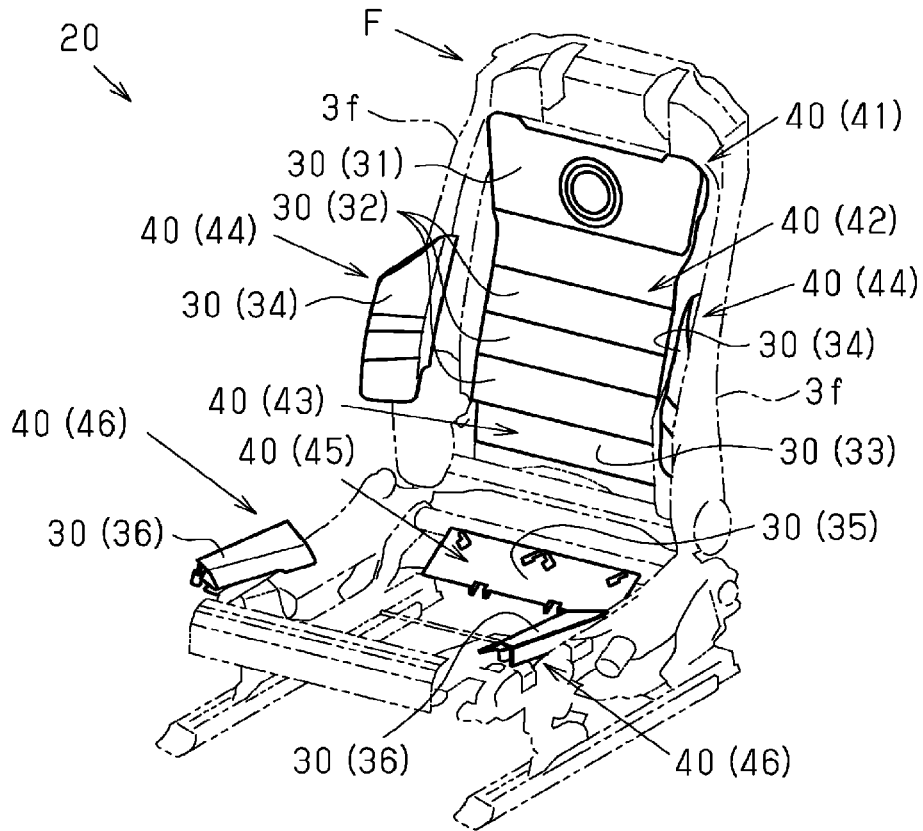

Fig. 4

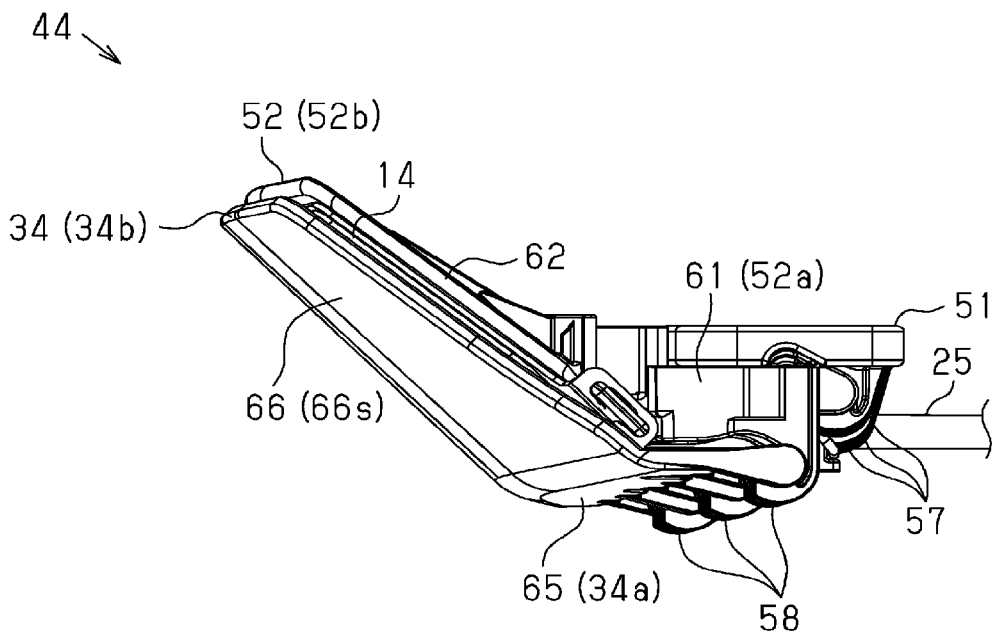

Fig. 5

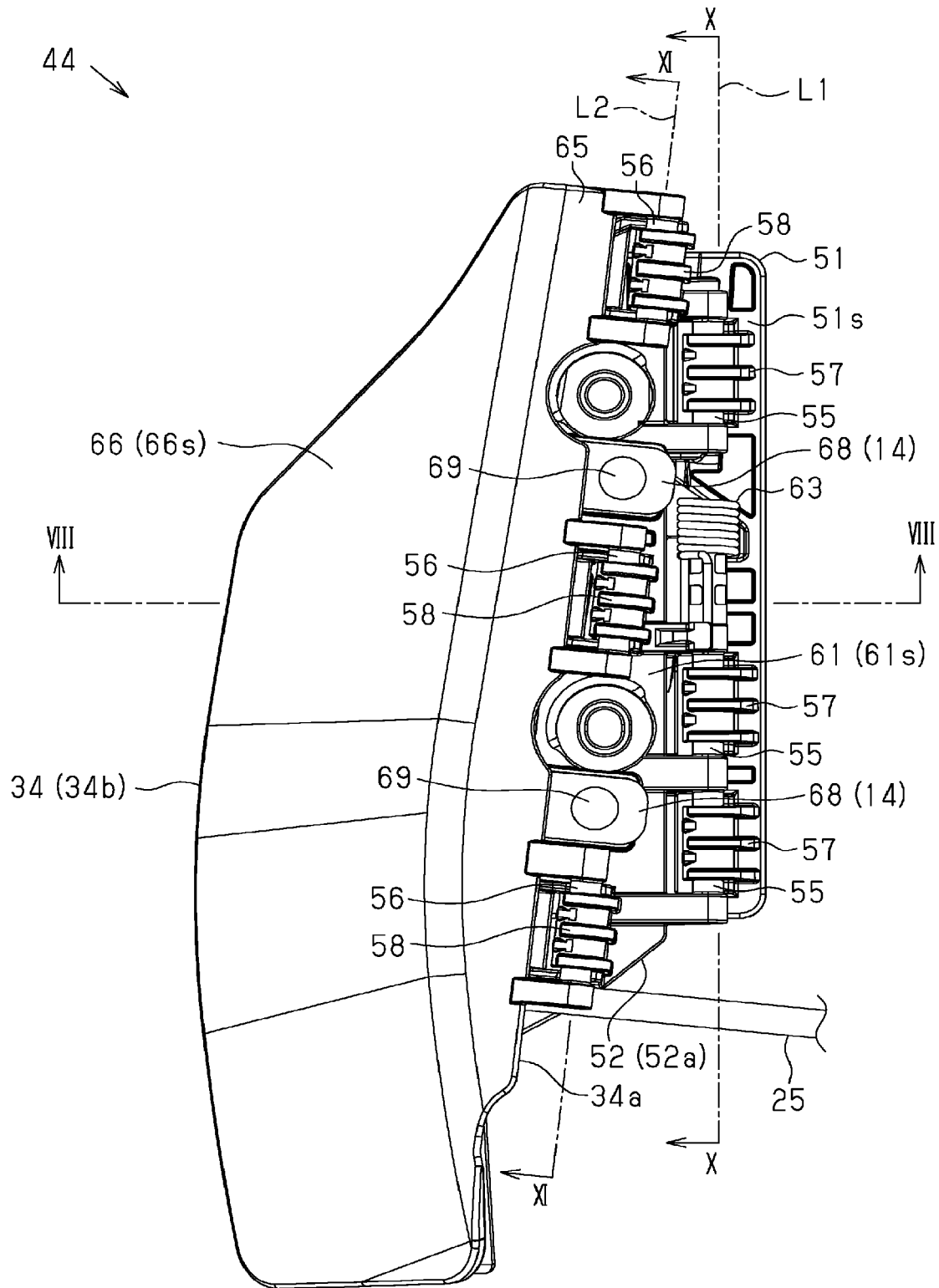

Fig.6

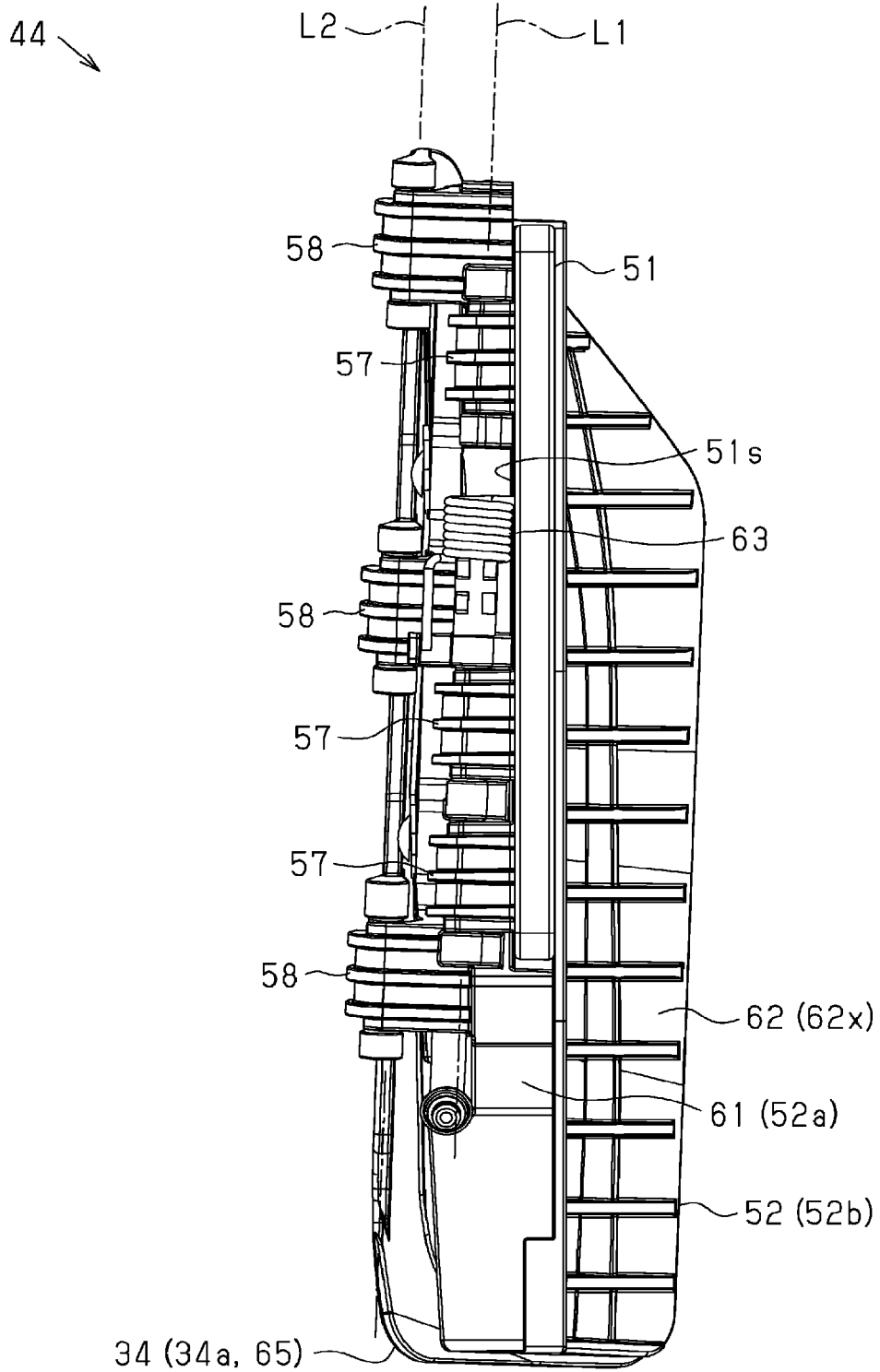

Fig. 7

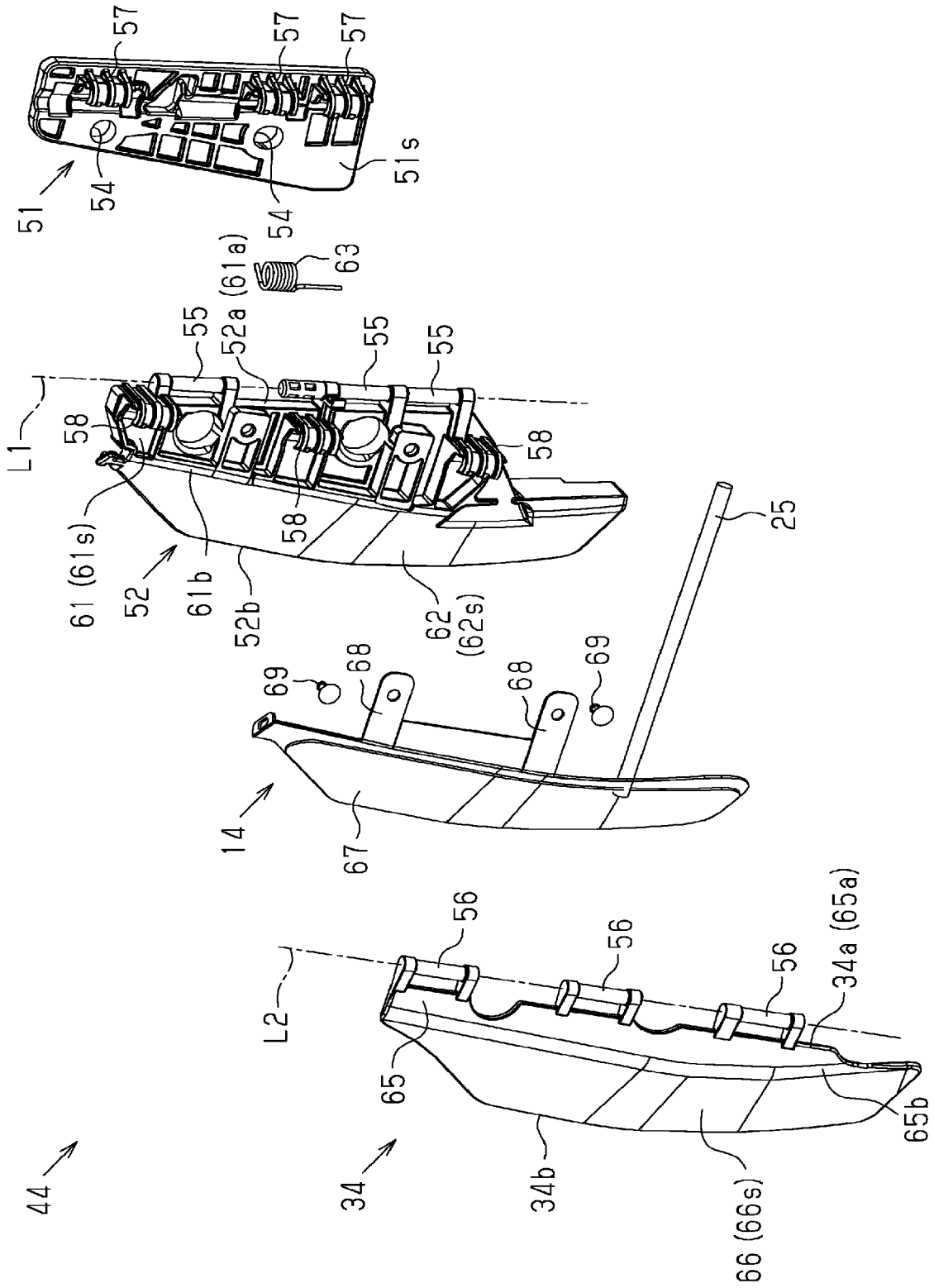

Fig. 8

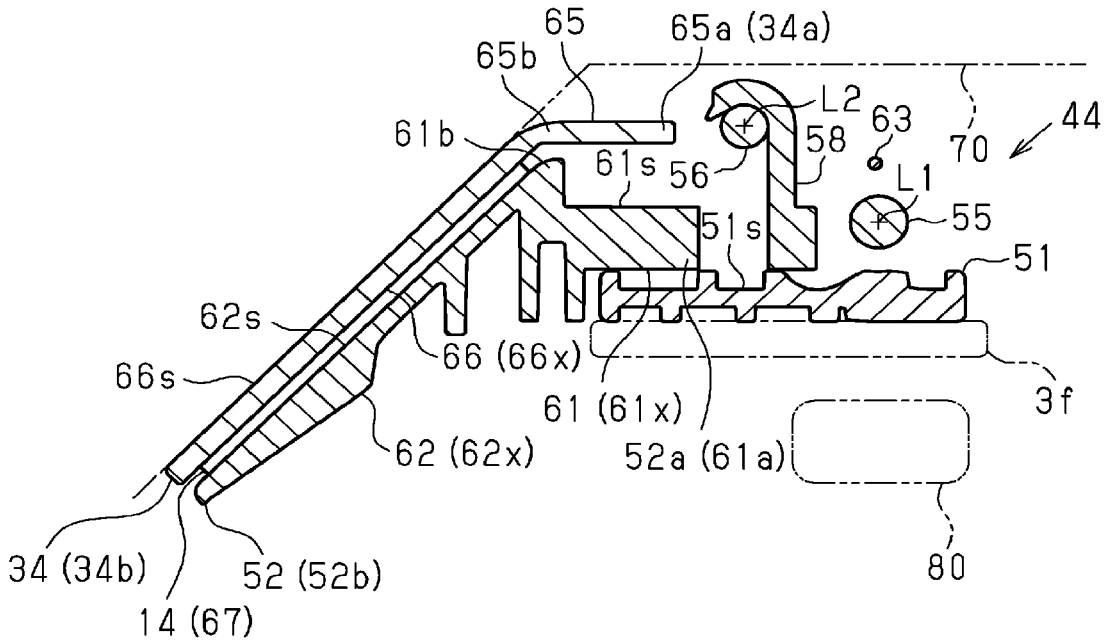

Fig. 9

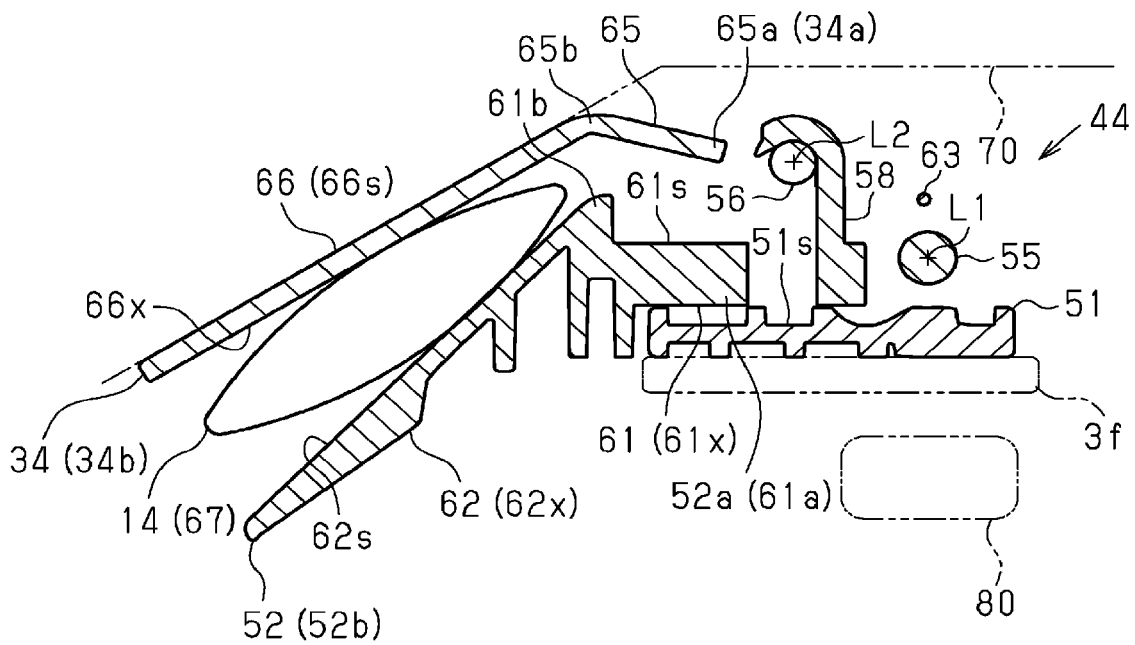

Fig. 10

44 ↘

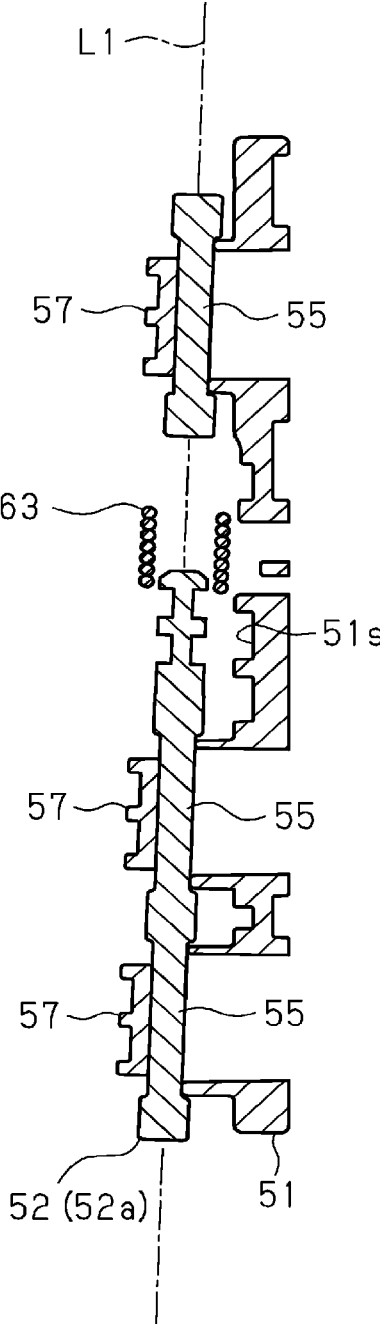

Fig. 11

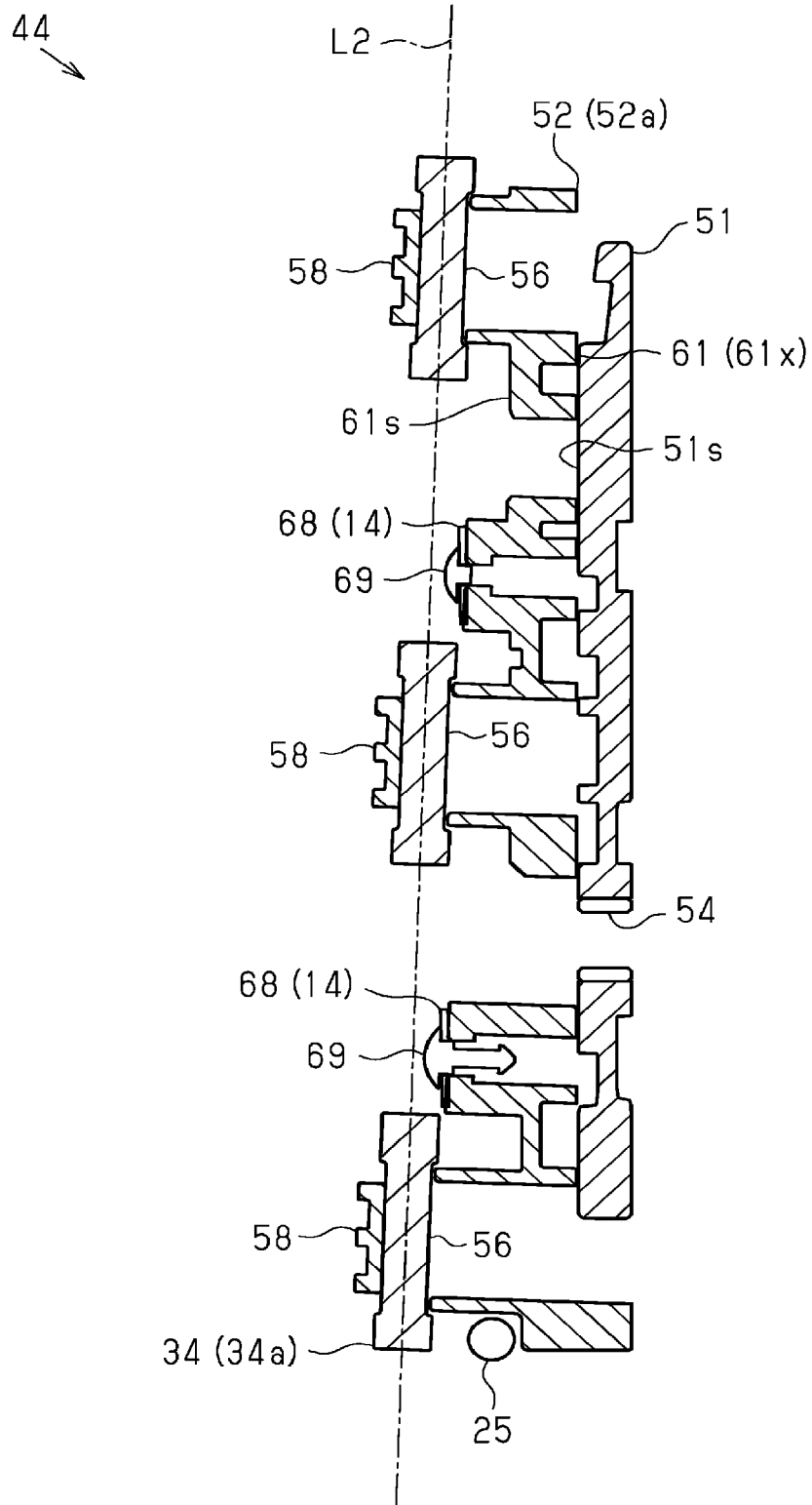
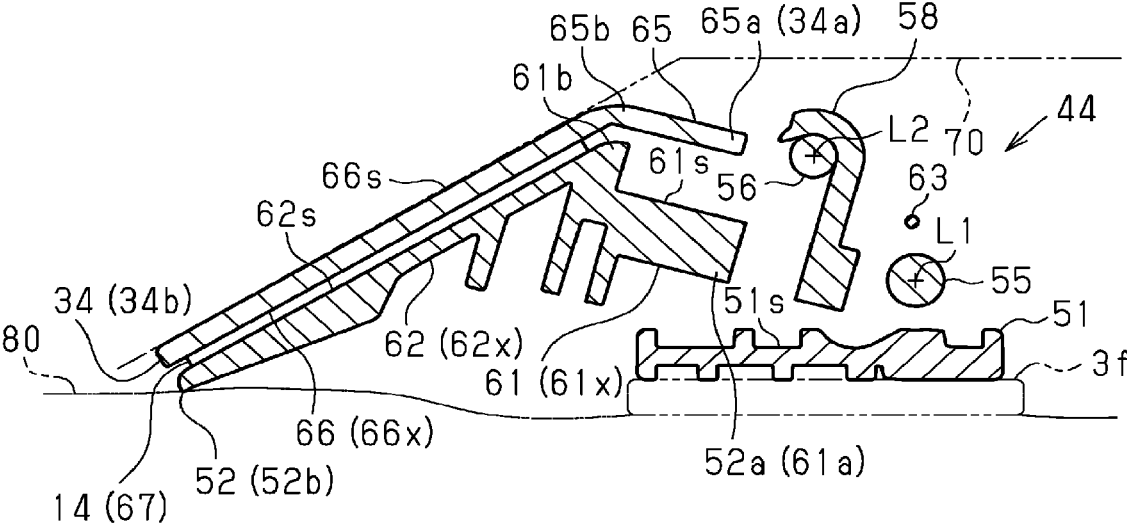

Fig. 12



1

VEHICLE SEAT DEVICE

TECHNICAL FIELD

The present invention relates to a vehicle seat device.

BACKGROUND ART

In the prior art, a vehicle seat device may include air packs (bladders) arranged inside a seat that are inflated and deflated so as to change the form of a support of the seat. Patent document 1 describes an example of a seat device including a clip (fixed portion), a base bracket (movable portion), a paddle, and an air pack. The clip is fixed to a structural body of the seat. The base bracket is pivotally coupled to the clip. The paddle is pivotally coupled to the fixed portion about the same pivot axis as the base bracket. The air pack is inflated and deflated between the paddle and the base bracket.

With this seat device, when the air pack, which is arranged between the base bracket and the paddle, is inflated, the air pack presses and pivots the paddle. Then, the paddle presses a cushion pad from the inner side to change the form of a support of the seat.

Further, when a side airbag, which is arranged in the seat, is deployed, the base bracket is pressed by the expanding side airbag and pivoted together with the paddle and the air pack. This allows for deployment of the side airbag.

PRIOR ART LITERATURE

Patent Literature

Patent Document 1: Japanese Laid-Open Patent Publication No. 2014-151822

SUMMARY OF THE INVENTION

Problem to be Solved by the Invention

When the side airbag is deployed, the side airbag needs to be expanded quickly and smoothly. In this regard, it is preferred that the base bracket of the conventional seat device be greatly moved so as not to interfere with the deployment action of the side airbag. Nevertheless, when adjusting the seat support form, it is desired that the paddle, which presses against the seat upholstery from the inner side, be moved as finely as possible. It is difficult for the structure of the prior art to solve the two problems. In this regard, there is room for improvement.

One object of the present invention is to provide a vehicle seat device that ensures quick and smooth deployment action of a side airbag and allows for adjustment of the seat support form in a further preferred manner.

Means for Solving the Problem

A vehicle seat device that achieves the above object according to one embodiment of the present disclosure includes a fixed base, a movable base, a paddle, and an air pack. The fixed base is fixed to a structural body of a seat. The movable base is pivotally coupled to the fixed base. The paddle is pivotally coupled to the movable base. The air pack is inflated and deflated between the movable base and paddle. When a side airbag arranged in the seat is deployed, the expanding side airbag presses and pivots the movable base and allows for a deployment of the side airbag. The

2

paddle is configured to change a seat support form when pressed and pivoted by the air pack. The movable base pivots about a first pivot axis relative to the fixed base. The paddle pivots about a second pivot axis relative to the movable base. The first pivot axis and the second pivot axis are arranged at different locations.

BRIEF DESCRIPTION OF THE DRAWINGS

FIG. 1 is a perspective view of a vehicle seat according to one embodiment of the present invention including air packs.

FIG. 2 is a schematic diagram of a seat device shown in FIG. 1.

FIG. 3 is a perspective view of a support assembly arranged in the seat shown in FIG. 2.

FIG. 4 is a top view of a back side support assembly (BS support assembly) shown in FIG. 3.

FIG. 5 is a side view of the BS support assembly shown in FIG. 4.

FIG. 6 is a rear view of the BS support assembly shown in FIG. 5.

FIG. 7 is an exploded perspective view of the BS support assembly shown in FIG. 5.

FIG. 8 is a cross-sectional view of the BS support assembly shown in FIG. 5 (cross-section taken along line VIII-VIII in FIG. 5 during air pack deflation).

FIG. 9 is a cross-sectional view of the BS support assembly shown in FIG. 5 (cross-section taken along line VIII-VIII in FIG. 5 during air pack inflation).

FIG. 10 is a cross-sectional view of the BS support assembly shown in FIG. 5 (cross-section taken along line X-X in FIG. 5).

FIG. 11 is a cross-sectional view of the BS support assembly shown in FIG. 5 (cross-section taken along line XI-XI in FIG. 5).

FIG. 12 is a cross-sectional view of the BS support assembly shown in FIG. 5 (cross-section taken along line VIII-VIII in FIG. 5 during side airbag deployment).

EMBODIMENTS OF THE INVENTION

One embodiment of a vehicle seat device that has a pneumatic seat support function will now be described with reference to the drawings.

As shown in FIG. 1, a vehicle seat 1 includes a seat cushion 2 and a seat back 3 arranged at a rear end of the seat cushion 2. Further, the seat back 3 includes an upper end where a head rest 4 is arranged.

With the seat 1 of the present embodiment, the seat back 3 includes side portions 3a and 3b that are bulged forward. Further, the seat cushion 2 also includes side portions 2a and 2b that are bulged upward. This allows the seat 1 of the present embodiment to be set in a desirable seating position for a vehicle occupant and maintain the seating position.

The seat 1 includes a plurality of air packs 10 (11 to 16) inside the seat cushion 2 and the seat back 3. Specifically, with the seat 1 of the present embodiment, the seat back 3 includes a backrest surface 3s and independent air packs 11, 12, 13, and 14. The air packs 11 (11a and 11b) are arranged inside the seat back 3 at locations corresponding to a shoulder portion (shoulder) of the backrest surface 3s, the air packs 12 (12a to 12c) are arranged inside the seat back 3 at locations corresponding to a waist portion (lumbar) of the backrest surface 3s, the air pack 13 is arranged inside the seat back 3 at a location corresponding to a lower end portion (back pelvis) of the backrest surface 3s, and the air

packs **14** (**14a** and **14b**) are arranged inside the seat back **3** at locations corresponding to the side portions **3a** and **3b**. Further, the seat cushion **2** includes a seating surface **2s** and independent air packs **15** and **16**. The air pack **15** is arranged at an inner side of a rear end portion (cushion pelvis) of the seating surface **2s**, and the air packs **16** (**16a** and **16b**) are respectively arranged at an inner side of the side portions **2a** and **2b** of the seating surface **2s**. Accordingly, in the seat **1** of the present embodiment, a seat device **20** has a seat support form that can be changed by inflating and deflating the air packs **10**.

As shown in FIG. 2, the seat device **20** of the present embodiment includes an air pump device **21** and an intake/discharge valve device **22**. The air pump device **21** sends pressurized air to the air packs **10**. The intake/discharge valve device **22** is arranged between the air packs **10** and the air pump device **21**. The air pump device **21** of the present embodiment includes an electric pump of which the drive source is a motor **23** to drive a pump mechanism **24**. Further, the intake/discharge valve device **22** is connected to the air packs **10** and the air pump device **21** with flexible resin tubes **25**. In the seat device **20** of the present embodiment, the tubes **25** and an inner passage of the intake/discharge valve device **22** form an air passage X that is in communication with the air packs **10** and the air pump device **21**. Further, the intake/discharge valve device **22** of the present embodiment includes an intake valve **26** and a discharge valve **27** that are located in the passage X.

In the seat device **20** of the present embodiment, a control device **28** controls the actuation of the intake valve **26**, the discharge valve **27**, and the air pump device **21**. Specifically, the control device **28** in the present embodiment receives signals including a signal indicating an inner pressure P of each of the air packs **10**, an operation input signal Sc generated in correspondence with an input to an operation switch (not shown), an ignition signal Sig, and a door lock signal Sdl. Based on the input signals, the control device **28** in the present embodiment is configured to control the actuation of the intake valve **26**, the discharge valve **27**, and the air pump device **21** to inflate and deflate the air packs **10**.

In further detail, as shown in FIG. 3, in the seat device **20** of the present embodiment, the air packs **10** are fixed to a seat frame F, which serves as a structural body of the seat **1**, in a state integrated with paddles **30** (**31** to **36**), which serve as pressing members, as support assemblies **40** (**41** to **46**). More specifically, the support assemblies **40** move the paddles **30** when the air packs **10** are inflated or deflated. The support assemblies **40**, each serving as a seat support device, are configured to change the seat support form when the paddles **30** press a cushion pad (not shown) at locations where the support assemblies **40** are arranged.

BS Support Assembly

The structure of back side support assemblies **44** (BS support assembly) arranged in the seat **1** of the present embodiment will now be described.

As shown in FIGS. 4 to 9, in the seat device **20** of the present embodiment, the BS support assemblies **44** that correspond to the side portions **3a** and **3b** of the seat back **3** (refer to FIG. 1) each include a fixed base **51** and a movable base **52**. The fixed base **51** is fixed to a side frame **3f** of the seat back **3** (refer to FIG. 2). The movable base **52** is pivotally coupled to the fixed base **51**. Further, each BS support assembly **44** in the present embodiment includes a paddle **34**, which configures a pressing member, pivotally coupled to the movable base **52**. The back side support air pack **14** is arranged between the paddle **34** and the movable base **52**.

More specifically, as shown in FIGS. 7 and 8, in each BS support assembly **44** of the present embodiment, the fixed base **51** is a substantially flat plate. Further, the fixed base **51** includes a plurality of bolt insertion holes **54** that extends through the fixed base **51** in a thickness-wise direction. The fixed base **51** in the present embodiment uses the bolt insertion holes **54** to be fastened to the side frame **3f** of the seat back **3** from the inner side (upper side in FIG. 8) in a widthwise direction of the seat (refer to FIG. 3).

The movable base **52** is flap-shaped and includes a basal end where shafts **55** are arranged and extend in a longitudinal direction of the movable base **52**. The paddle **34** is flap-shaped and includes a basal end **34a** where shafts **56** are arranged and extending in a longitudinal direction of the paddle **34**. Accordingly, the BS support assembly **44** in the present embodiment is configured in a state in which the fixed base **51**, the movable base **52**, and the paddle **34** are stacked and coupled in the thickness-wise direction.

Specifically, as shown in FIGS. 5 to 7 and 10, the fixed base **51** in the present embodiment includes hooks **57** that engage the shafts **55** of movable base **52**. The hooks **57** project from a front surface **51s** of the substantially flat plate fixed base **51**. Each of the hooks **57** includes a distal end that is bent back to be substantially U-shaped in conformance with the substantially cylindrical shafts **55** of the movable base **52**. In the BS support assembly **44** of the present embodiment, engagement of the shafts **55** and the hooks **57** forms a pivot axis L1 of the movable base **52** relative to the fixed base **51**.

Further, as shown in FIGS. 5 to 9 and 11, in the BS support assembly **44** of the present embodiment, the movable base **52** also includes hooks **58** that engage the shafts **56** of the paddle **34**. Each hook **58** includes a distal end bent back to be substantially U-shaped in conformance with the substantially cylindrical shafts **56** of the paddle **34**. In the BS support assembly **44** of the present embodiment, engagement of the shafts **56** and the hooks **58** forms a pivot axis L2 of the paddle **34** relative to the movable base **52**.

More specifically, the movable base **52** in the present embodiment includes a base portion **61** that is a substantially flat plate and an extension portion **62**. The base portion **61** includes a first end **61a** (refer to FIG. 7, right side in drawing) that is the basal end **52a** where the shafts **55** are arranged. The extension portion **62** extends in a state bent from a second end **61b** (left side in FIG. 7) at a side opposite to the first end **61a**. The hooks **58** project from a front surface **61s** of the base portion **61**.

As shown in FIGS. 5 to 9, in the BS support assembly **44** of the present embodiment, the second pivot axis L2 about which the paddle **34** pivots relative to the movable base **52** is arranged at a location closer to a distal end **52b** of the movable base **52** (refer to FIG. 8, left side in drawing) than the first pivot axis L1 about which the movable base **52** pivots relative to the fixed base **51**. Further, the BS support assembly **44** in the present embodiment is configured so that the first pivot axis L1 and the second pivot axis L2 are in a positional relationship (skew positional relationship) in which the second pivot axis L2 is inclined relative to the first pivot axis L1 (refer to FIG. 5).

Further, when the shafts **55** engage the hooks **57** of the fixed base **51**, the movable base **52** of the present embodiment is arranged in a state in which the base portion **61** overlaps the fixed base **51** (surface **51s**). In such a state, the extension portion **62** extends toward the front of the seat **1** (left side in FIG. 8) and projects outward (from upper side to lower side in FIG. 8) from the inner side in the widthwise direction of the seat.

5

The BS support assembly 44 in the present embodiment includes a torsion coil spring 63 that is arranged coaxially with the shafts 55 of the movable base 52. In the BS support assembly 44 of the present embodiment, the torsion coil spring 63 functions as a biasing member that pivots the movable base 52 in a direction in which the base portion 61 of the movable base 52 is pressed against the fixed base 51 (refer to FIG. 8, counterclockwise in drawing). This holds the movable base 52 of the present embodiment at a position where a back surface 61x of the base portion 61 is in contact with the surface 51s of the fixed base 51.

In the same manner as the movable base 52, the paddle 34 of the present embodiment includes a base portion 65 that is a substantially flat plate and an extension portion 66. The base portion 65 includes a first end 65a (refer to FIG. 7, right side in drawing) that is the basal end 34a where the shafts 56 are arranged. The extension portion 66 extends in a state bent from a second end 65b (left side in FIG. 7) at a side opposite to the first end 65a. Further, when the shafts 56 engage the hooks 58 of the movable base 52, the paddle 34 is also arranged in a state in which the base portion 65 overlaps the base portion 61 of the movable base 52. In such a state, in the paddle 34 of the present embodiment, the extension portion 66 is arranged in a state overlapping the extension portion 66 of the movable base 52 that extends outward (refer to FIG. 8, lower side in drawing) and toward the front of the seat 1 (left side in FIG. 8) from the inner side in the widthwise direction of the seat.

As shown in FIGS. 7 to 9, each of the back side support air packs 14 has a pack portion 67 that includes two straps 68 extending from an end of the pack portion 67. The pack portion 67 is set to be flat when deflated to conform to the shapes of the extension portions 62 and 66 of the movable base 52 and the paddle 34. The air pack 14 of the present embodiment is configured so that the pack portion 67 is arranged between the extension portion 62 of the movable base 52 and the extension portion 66 of the paddle 34 in a state in which a clip 69 fixes each of the straps 68 to the base portion 61 of the movable base 52.

As shown in FIGS. 8 and 9, in the BS support assembly 44 of the present embodiment, inflation and deflation of the air pack 14, which is arranged between the paddle 34 and the movable base 52, pivots the paddle 34 about the second pivot axis L2 relative to the movable base 52. More specifically, when filled with air and inflated, the air pack 14 presses the extension portion 62 of the movable base 52 (front surface 62s) and the extension portion 66 of the paddle 34 (back surface 66x), which are in contact with the air pack 14. However, the back surface 61x of the base portion 61 is in contact with the front surface 61s of the fixed base 51. This restricts pivoting of the movable base 52 in a direction in which the air pack 14 presses the movable base 52 (counterclockwise in FIGS. 8 and 9). Accordingly, the BS support assembly 44 of the present embodiment is configured so that the paddle 34 pivots in a direction in which the air pack 14 presses the paddle 34 (clockwise in FIGS. 8 and 9).

Thus, when the air pack 14 presses and pivots the paddle 34, a distal end 34b of the paddle 34 moves toward the inner side in the widthwise direction of the seat (upper side in FIGS. 8 and 9). Further, in this case, the paddle 34 is arranged at a location where the extension portion 66 (front surface 66s) presses a cushion pad 70, which is arranged at the inner side of a seat surface is (refer to FIG. 1), from the outer side in the widthwise direction of the seat (lower side in FIGS. 8 and 9). This allows the BS support assembly 44

6

in the present embodiment to change the seat support form of the side portions 3a and 3b of the seat back 3.

As shown in FIGS. 8, 9, and 12, the seat 1 in the present embodiment includes a side airbag 80 at a location outward in the widthwise direction of the seat from the BS support assembly 44, which is fixed to the side frame 3f of the seat back 3. When an inflator (not shown) generates gas during a vehicle collision, the side airbag 80 is configured to be expanded and deployed toward the front of the seat 1 (left side in FIGS. 8, 9 and 12) from a side edge of the seat back 3.

When the side airbag 80 is not deployed, the BS support assembly 44 in the present embodiment includes the movable base 52 (the extension portion 66) extending outward from the inner side in the widthwise direction of the seat toward the front of the seat 1. The distal end 52b of the movable base 52 is arranged at a location outward from the side frame 3f of the seat back 3 in the widthwise direction of the seat. That is, when the side airbag 80 is deployed, the distal end 52b of the movable base 52 is arranged at a location where the expanding side airbag 80 presses a back surface 62x of the extension portion 62 on the movable base 52. In this case, the movable base 52 is pivoted about the first pivot axis L1 (refer to FIG. 12, clockwise in drawing) relative to the fixed base 51 by the pressing force of the side airbag 80 against the biasing force of the torsion coil spring 63. This moves the distal end 52b of the movable base 52, which is arranged forward from the side airbag 80, toward the inner side in the widthwise direction of the seat. Accordingly, the BS support assembly 44 in the present embodiment allows for deployment of the side airbag 80.

The above embodiment has the advantages described below.

(1) The BS support assembly 44 includes the fixed base 51, the movable base 52, the paddle 34, and the air pack 14. The fixed base 51 is fixed to the side frame 3f of the seat back 3. The movable base 52 is pivotally coupled to the fixed base 51. The paddle 34 is pivotally coupled to the movable base 52. The air pack 14 is inflated and deflated between the paddle 34 and the movable base 52. When the side airbag 80 arranged in the seat 1 is deployed, the expanding side airbag 80 presses and pivots the movable base 52 and allows for deployment of the side airbag 80. Further, the air pack 14 presses and pivots the paddle 34 to change the seat support form of the side portions 3a and 3b of the seat back 3. With the BS support assembly 44, the pivot axis L1 of the movable base 52 relative to the fixed base 51 and the pivot axis L2 of the paddle 34 relative to the movable base 52 are arranged at different locations.

With the above structure, the optimal pivot axis L1 can be set for the movable base 52 so that the movable base 52 pivots without interfering with the deployment action of the side airbag 80. Further, the optimal pivot axis L2 of the paddle 34 can be set to change the seat support form. This ensures quick and smooth deployment action of the side airbag 80 and adjusts the seat support in a further preferred manner.

(2) The second pivot axis L2 about which the paddle 34 pivots relative to the movable base 52 is arranged at a location closer to the distal end 52b of the movable base 52 than the first pivot axis L1 about which the movable base 52 pivots relative to the fixed base 51.

In the above structure, the movable base 52 is greatly moved so as not to interfere with the deployment action of the side airbag 80, and the paddle 34 is moved further finely.

This ensures quick and smooth deployment action of the side airbag **80** and adjusts the seat support form in a further preferred manner.

(3) The BS support assembly **44** includes the torsion coil spring **63** arranged coaxially with the shafts **55** of the movable base **52**, that is, the pivot axis **L1** of the movable base **52** relative to the fixed base **51**. The torsion coil spring **63** functions as a biasing member that pivots the movable base **52** in the direction in which the movable base **52** is pressed against the fixed base **51**, that is, in the direction (refer to FIG. **8**, counterclockwise in drawing) opposite to a direction in which the side airbag **80** presses and pivots the movable base **52**.

In the above structure, for example, even when the backrest surface **3s** of the seat back **3** is manually pulled toward the front thereby pivoting the movable base **52** in the same direction as when the side airbag **80** is deployed, the biasing force (elastic resiliency) of the torsion coil spring **63** returns the movable base **52** to its original position. As a result, high reliability and a high quality are obtained.

Further, the torsion coil spring **63**, which is arranged coaxially with the pivot axis **L1** of the movable base **52**, is used as the biasing member so that the torsion coil spring **63** does not interfere with the deployment of the side airbag **80**. This ensures quick and smooth deployment action of the side airbag **80**. Additionally, this reduces the layout area of the torsion coil spring **63**. Accordingly, the BS support assembly **44** can be reduced in size.

(4) The movable base **52** is held by the biasing force of the torsion coil spring **63** at a location where the base portion **61** (back surface **61x**) is in contact with the fixed base **51** (front surface **51s**).

The above structure restricts the pivoting of the movable base **52** by the pressing force of the inflating air pack **14**. This efficiently pivots the paddle **34** with the pressing force of the inflating air pack **14**. As a result, the seat support form is adjusted in a further preferred manner.

The above embodiment may be modified as described below.

In the above embodiment, the present invention is embodied in the back side support assemblies (BS support assemblies **44**) that change the seat support form of the side portions **3a** and **3b** of the seat back **3**. However, when side airbags are arranged in the seat cushion **2**, the present invention may be applied to cushion side support assemblies (CS support assemblies) **46** that change the seat support form of the side portions **2a** and **2b**.

In the above embodiment, the torsion coil spring **63**, which is arranged coaxially with the pivot axis **L1** of the movable base **52**, is used as the biasing member that pivots the movable base **52**. However, the type and location of the biasing member are not limited and may be changed. The

present invention may be applied to a structure that does not include such a biasing member.

In the above embodiment, the fixed base **51** is fixed to the side frame **3f** of the seat back **3**. However, the structural body of the seat **1** to which the fixed base **51** is fixed may be changed.

The fixed base **51**, the movable base **52**, and the paddle **34** may have any shape.

In the above embodiment, the pivot axis **L1** of the movable base **52** (first pivot axis) and the pivot axis **L2** of the paddle **34** (second pivot axis) are configured to have a positional relationship (skew positional relationship) in which the pivot axis **L1** and the pivot axis **L2** are inclined. However, the first and second pivot axis **L1** and **L2** may be parallel to each other. The present invention is not restrictive to a structure in which the second pivot axis **L2** is arranged at a location closer to the basal end **52a** of the movable base **52** than the first pivot axis **L1**.

The invention claimed is:

1. A vehicle seat device, comprising:

a fixed base fixed to a structural body of a seat;
a movable base pivotally coupled to the fixed base;
a paddle pivotally coupled to the movable base; and
an air pack inflated and deflated between the movable base and the paddle, wherein

when a side airbag arranged in the seat is deployed, the expanding side airbag presses and pivots the movable base and allows for a deployment of the side airbag, the paddle is configured to change a seat support form when pressed and pivoted by the air pack,

the movable base pivots about a first pivot axis relative to the fixed base,

the paddle pivots about a second pivot axis relative to the movable base, and

the first pivot axis and the second pivot axis are arranged at different locations.

2. The vehicle seat device according to claim 1, wherein the second pivot axis is arranged at a location closer to a distal end of the movable base than the first pivot axis.

3. The vehicle seat device according to claim 1, further comprising:

a biasing member;

wherein the biasing member biases the movable base in a direction opposite to a direction in which the side airbag presses and pivots the movable base.

4. The vehicle seat device according to claim 3, wherein the biasing member is a torsion coil spring that is arranged coaxially with the first pivot axis.

5. The vehicle seat device according to claim 3, wherein the movable base is held by a biasing force of the biasing member at a location contacting the fixed base.

* * * * *