

(19)



OIFIG NA bPAITINNÍ
PATENTS OFFICE

(11) **IE 20170134**

(13) **A2**

(43) Date of Publication of Application:
03.04.2019 Journal No. 2382

(12)

IRISH SHORT-TERM PATENT APPLICATION

(21) Application Number: **20170134**

(22) Date of Filing: **23.06.2017**

(51) Int. Cl. (2019.01)
E04F 10/00
B60J 11/00
G05B 19/00

(71) Applicant(s):
ANDREI LARIONOV
Co. Wicklow
Ireland

(72) Inventor(s):
ANDREI LARIONOV

(74) Agent and/or Address for Service:
ANDREI LARIONOV
47 Woodlands Park
Arklow
Co. Wicklow
Ireland

(54) **Motorised retractable roofing system**

(57) The present invention relates to outdoor structures/shelters. In particular the invention provides a motorised retractable roofing system comprising: a rigid frame around a covering area built of two parallel multifunctional sliding channels coupled with a stacking frame positioned on the front or/and back sides of the system, required number of retractable sections able to cover an entire territory, and a driving mechanism fitted in a way, that the first retractable section performs the function of a locomotive pushing other retractable sections when opening and pulling them when closing. The advantage of this invention is that the applied materials and the unique stacking design make the product light and durable, convenient and safe in use, lights transparent, wind resistant, functional and at the same time elegant and affordable, and delivering a wide variety of options using an outside area 365 days a year, regardless of the weather condition.

TRUE COPY
AS
LODGED

-1-

A Motorised Retractable Roofing System (MRRS)

Field of the Invention

The present invention relates to outdoor structures/shelters, but can be used as a roof section on other structures/buildings. A smaller version also can be installed, for example,
5 on the city tour buses.

Background of the Invention

Vast majority of houses/terraces are equipped with back gardens. Due to the rainy features of the Irish weather, the average percentage of using back gardens in a good year can reach only 50%. It is very unlikely that back gardens will be in use during rough
10 weather condition disturbing children playing, drying clothes, barbeque/birthday parties, gardening, leisure and so on.

Currently on the market there exists the following opportunities to solve this problem: canvas awnings, rigid shelters and sunrooms/conservatoriums.

Retractable canvas awnings are represented as two main designs: compact with fixing to
15 the wall and a rigid structure with supporting roofing beams and retractable canvas sections. There are three main problems with canvas awnings: poor wind resistance, no light transmission and canvas maintenance and wear.

Rigid shelters provide good rain protection, but also block sun light and restrict a range of outdoor activities.

20 The sunrooms/conservatoriums is an extension to a house and is quite expensive.

Another very important limitation for using rigid structures is the requirements for planning permission if you are going to build a structure that exceeds 25sq/m.

The most famous types of retractable roofs/enclosures around the world apply telescopic and multilayer principles of operation. Both types require an individual sliding track for
25 each retractable section. The more sections used, the wider the sliding tracks (vertically

for multilayer and horizontally for telescopic) will be. It creates certain restrictions for their applications and difficulties for the rainwater to gather.

The idea of the retractable roofing system with multifunctional sliding channels has been implemented in constructing the MRRS. All negative aspects of existing products have
5 been taken into account of its design, and a number of innovative solutions have been implemented. The applied materials and the unique stacking design make the product light and durable, convenient and safe in use, lights transparent, wind resistant, functional and at the same time elegant and affordable.

The MRRS can be presented in several variants of shape and form adjusted to the size of
10 the premises and different finishes accordingly to the requirements.

A supporting frame of the MRRS is positioned around the covering perimeter and can be integrated into existing landscape (along fencing of a back garden) or can create its own borders with side walls as an option. A rigid section, as a part of a stacking frame, normally adjoins houses/buildings creating a permanent structure covering
15 entrances/patios and providing safe storage of the retractable sections. The rest of the covering territory is free of any structural elements, but if required can be fully covered by retractable sections. A remote control, a manual switch and a rain sensor activates a driving mechanism which starts moving the retractable sections towards the far end between the parallel multifunctional sliding channels. Now, the entire territory is
20 protected against rain and UV light and has enough daylight to continue active usage. All rainwater flows into the gutter which is a part of the multifunctional sliding channel.

Accordingly, there exists a need for an elegant and affordable retractable roofing/shelter system which is safe and convenient in use, possessing with good wind resistance, protecting against UV light and rain, light transparent and delivering an opportunity:

25 to extend useful area of private/public/commercial premises (such as mobile home, back/side/front gardens, play/sport grounds, trade/show areas etc.),

to enjoy the sunshine, fresh air and wide variety of activities during good weather and continue an active and comfortable use of the area during poor weather condition such as rain/ wind,

to extend the life of your outdoor/gardening/leisure equipment.

5 Summary of the Invention

According to the invention there is provided, as set out in the appended claims, a motorised retractable roofing system comprising:

- 10 • a pair of multifunctional sliding channels positioned parallel from both sides of a covering area creating a supporting frame which is coupled into a single rigid structure with
- a stacking frame positioned on the front or/and back sides of the system and comprising a rigid section, elevating slopes and stacking brackets operating with a tri-linear wheel system,
- 15 • required number of retractable sections able to cover an entire territory and where each section is equipped with a pair of sliders fitted with wheels and rollers representing a tri-linear wheel system which is applied for the sliding and stacking process providing unceasing motion and convenient stacking of sections on top of each other,
- 20 • a driving mechanism fitted in a way, that the first retractable section performs the function of a locomotive pushing other retractable sections when opening and pulling them when closing.

The supporting frame has to be rectangular or parallelogram in form and can be fixed on pole supports and/or side walls. It can be detached/semi-detached or be a roofing section on another building/structure. Additionally, the frame can be supplied with side panels to 25 enclose the covered area.

The multifunctional sliding channel is a key element of the MRRS as it supports and provides all essential functions for system operation:

- Supporting, directing and securely holding retractable sections,
- Providing a convenient opportunity to fix mount brackets and elements of a driving mechanism,
- Requires minimum modifications to fit a rigid section and other elements of the stacking frame – elevating slopes and stacking brackets,
- Gathering all rain water.

In one embodiment the multifunctional sliding channel is a specially designed profile which is made using an aluminium extrusion method and combines the following functional parts: a supporting profile, a sliding channel with directional tracks (minimum two) and a gutter.

In one embodiment the stacking frame positioned on the front of the supporting frame and comprises: a pair of modified multifunctional sliding channels, a rigid section, two pairs of elevating slopes and two pairs of stacking brackets.

In one embodiment the rigid section fixed directly to the gutter of the multifunctional sliding channels. It provides rigidity to the entire structure and a reliable base for the stacked retractable sections above it.

In one embodiment elevating slopes are integrated into modified multifunctional sliding channels along sliding tracks. They apply the mechanical advantage of an inclined plane through specially calculated angles of the slopes that significantly reduce required power of the geared motors and provide smooth, simultaneous movement of the retractable sections up and down.

In one embodiment the stacking brackets are attached to the top of the modified multifunctional sliding channels above elevated slopes and specially designed to facilitate the stacking process and to fix the stacked sections safely.

In one embodiment the retractable sections comprise a pair of sliders, minimum two carrier profiles, required number of purlins and roofing panels.

In one embodiment the carrier profiles can be attached to sliders at an angle 0-45° which allows building of various roof shapes: an arch, a triangle, a flat and a slope.

In one embodiment, from outside, sliders are fitted with two V-grooved wheels and the same number of supporting rollers positioned in a way that perfectly matches:

- the inside width of the sliding channel and stacking brackets to avoid any free movements of the retractable sections,
- 5 the positions of the elevating slopes to insure synchronous of the lifting process,
- the positions of the sliding tracks to provide smooth sliding motion.

In one embodiment the nylon wheels positioned at the front corner inside the sliders play a key role in the stacking process:

- they keep an appropriate gap between retractable sections in the closed position
- 10 and during stacking process,
- provide smooth redirection of vertical movement into horizontal movement and vice versa during stacking process insuring unceasing motion,
- provide sliding on top of the previous sliders keeping an appropriate gap between retractable sections in the stacking frame.

- 15 In one embodiment the V-grooved wheels and nylon wheels represent a tri-linear wheel system which together with sliding tracks, elevates slopes and sliders providing unceasing motion during the opening/closing process and convenient stacking of sections on top of each other.

- In one embodiment the retractable sections are linked with each other by Z connectors
- 20 fitted between sections on the carrier profiles. The gap between sections is covered with a protective bar attached to top of the front carrier profiles preventing rainwater leaks.

- In one embodiment two reversible geared motors are positioned on the internal side of the sliders on the first section which performs function of a locomotive pushing other sections when opening and pulling them when closing. The pinions of motors are hidden
- 25 inside sliders which are positioned above a gutter. Toothed racks are fixed inside a gutter

and reliably and safely interact with pinions implementing a drive mechanism of the MRRS.

In one embodiment the MRRS is equipped with the following electrical components: a control unit, a pair of limit switches, a pair of reversible geared motors, a remote control
5 and a manual open/close switch. As an option, a rain sensor and/or lighting can be installed.

A number of retractable sections and their shape and size can vary depending on the area dimensions and other requirements.

In one embodiment all frames on the MRRS are made of aluminium. Multiwall
10 polycarbonate panels (MWPC) are used as a roofing material.

For example going to be used an arch shaped MRRS with three retractable sections, as it can demonstrate all operational functions of the system.

Brief Description of the Drawings

The invention will be more clearly understood from following description of a preferred
15 embodiment thereof which is given by way of examples only with reference to the accompanying drawings, in which:

- Fig.1. Illustration of the MRRS, closed position, side view.
- Fig.2. Illustration of the MRRS, closed position, top view.
- 20 Fig.3. Illustration of the MRRS, closed position, front view.
- Fig.4. Illustration of the MRRS, opened position, side view.
- Fig.5. Illustration of the MRRS, opened position, top view.
- Fig.6. Illustration of the MRRS, opened position, front view.
- Fig.7. Illustration of the frame assembly, top view.
- 25 Fig.8a, b Illustrates the multifunctional sliding channel and its front view fully fitted with functional elements: elevating slopes, stacking brackets, the motor cable drag chain, toothed racks, mount brackets and the rigid section.

- Fig.9. a-c Illustrates side and top view of the right part of the stacking frame including the modified sliding channel, elevating slopes and stacking brackets.
- Fig.10. a-c Illustrates a few views of the inside elevating slopes and stacking brackets fixed to the modified multifunctional sliding channel, left.
- 5 Fig.11a-c Illustrates a few views of the outside elevating slopes and stacking brackets fixed to the modified multifunctional sliding channel, left.
- Fig.12a-c General illustration of the section components and their assembly and side and front view of the section.
- Fig.13a-d Illustrates a number of views of section 1 right slider including motor.
- 10 Fig.13e Section 1 left slider, bottom view.
- Fig.14a-d Illustrates a number of views of sections 2 and 3 right slider.
- Fig.15. Illustrates position of the slider's wheels inside of the multifunctional sliding channel, right, back view, representing a tri-linear wheel system.
- Fig.16. Illustrates position of the slider's wheels on directional tracks and inside stacking brackets, right, top view, representing a tri-linear wheel system.
- 15 Fig.17. Illustration of the Z connectors fitted on sliding sections, left, top view.
- Fig.18. Front view illustration of the left side Z connectors, attached to the outer side of the carrier profiles.
- Fig.19. Illustrates position of the spur gear drive mechanism including reversible geared motor with pinion, toothed racks and motor cable drag chain with holder, back view, right.
- 20 Fig.20. Front view illustration of the stacked sections in the right sliding channel.
- Fig.21. Position of electrical components.
- Fig.22. Electrical diagram.
- 25 Fig.23a-d Stacking process, closing, overview.
- Fig.24. Stacking process, closing, stage 1.
- Fig.25. Stacking process, closing, stage 2.
- Fig.26. Stacking process, opening, stage 1, outside slopes.
- Fig.27. Stacking process, opening, stage 1, inside slopes.
- 30 Fig.28. Stacking process, opening, stage 2.

Detailed Description of the Drawings

Referring now to the drawings and initially to fig. 1-6, there illustrated is a MRRS comprising:

- 5 • the frame around the perimeter of the covering territory comprising two parallel multifunctional sliding channels 5 reinforced with the supporting beam 22 from one side and with the staking frame (using inserts 25) from another side. The frame can be fixed on the pole supports 24 and/or side walls using the mount brackets 21,
- 10 • the stacking frame comprising the rigid section SN4 4, the modified multifunctional sliding channels 6, 7 and the stacking brackets 8-11,
- three retractable sections SN1 1 with optional side wall 68, SN2 2 and SN3 3, Two reversible geared motors 23.

Fig.7 shows a rigid part of the MRRS. Supporting beam 22 and the multifunctional sliding channels 5-7 can be extend using inserts 25 if required.

15 The most important element of the invention is shown in Fig.8 (a, b). The multifunctional sliding channel 5-7 is a key element of the MRRS and combines the following functional parts:

- 20 • The supporting profile 41 which supports retractable sections and has internal dimensions that fit the connecting inserts 25 and securely extend the length of the multifunctional sliding channel. Also, the supporting profile is sitting on the mount bracket 21 providing a convenient and secure way for their fixture.
- 25 • The channel 42 positioned on the top of the supporting profile, with two directional tracks (the inside 39 and the outside 40) for the V-grooved wheels 31. Tracks provide the motion direction of the retractable sections and have the distance between each other, allowing the back V-grooved wheels and rollers to bypass the inside elevating slopes 35 towards the outside elevating slopes 36 which are attached both sides of the tracks 39, 40 respectively.

The space between side wall and inside track 39 is targeted to discreetly hold the motor cable drag chain 45 which supplies the motor. The height of the channel should allow free movement of the motor cable drag chain.

- 5 • U-shaped water gutter 43 on the side of the supporting profile collects all rainwater flowing from the roof surface. In the place of the downpipe connection, the hole/holes should be drilled. Inside the gutter on the outside wall are fitted toothed racks 46, which interacting with the pinion of the motor providing motion to the retractable sections, Also, the outside wall of the gutter is used to fix the
- 10 carrier profiles fixtures 28 and the U profile 18 of the section 4.

The ends of the sliding channel have to be tightly closed with the special end caps 44. If required, the wall mount holes can be drilled in the cap.

The mount brackets 21 have dimensions that exactly match the underside of the sliding channel. They provide support to the multifunctional sliding channel and can be fixed to a

15 wall or to the top of the poles 24. Different variations of poles (metal, aluminium, wooden, square or round) can be used for the MRRS.

Fig.9 (a, b) shows the side and Fig.9 (c) the top view of the right part of the stacking frame. The multifunctional sliding channels 6, 7 of the stacking frame require a little modification:

- 20 a couple of slots on the top of the channel above the elevating slopes require free upward/downward movement of wheels and rollers by elevating the slopes,
- carrier profile fixtures 28 and U profile 18 of the section 4 have to be attached from outside the gutter. Section 4 is shorter than the retractable sections, leaving a space for the motors.
- 25 stacking brackets 8 and 10 are attached on the top of the sliding channel above the top end of the elevating slopes.

Position of elevating slopes 35, 36 and their angle can vary accordingly to the length of sliders 16, 17 and the weight of the retractable sections. The height of the inside elevating

slopes 35 are slightly shorter (approximately 1/3 of the nylon wheel 33 diameter) than the height of the outside elevating slopes 36.

Referring to Fig.10, 11, Fig.10 (a-c) shows how the pair of inside elevating slopes 35 are positioned from both sides of the inside track 39 and the inside stacking bracket 9 is positioned on top of the modified multifunctional sliding channel 7 which has a special design fitted with:

directional guide 37 assuring completeness of the opening stacking process through directing the nylon rollers 32, and

directional track 38 for the front V-grooved wheels.

10 Fig.11 (a-c) illustrates the same as above only for the outside track 40, the outside elevating slopes 36 and the outside stacking bracket 11. The end of the multifunctional sliding channel is covered with the end cap 44.

Fig.12 (a) represents essential elements required for the section assembly. Sliding sections comprise:

15 two sliders 14-17,
minimum two carrier profiles/beams 12, 13. They can be bent (Fig.12 b, c) to increase rigidity. The insert 25 reliably helps to extend the length of the carrier profiles,
purlins 26 create additional rigidity to the sections frame and support the roofing
20 panels. The middle purlin 27 is wider, providing secure joining of two roofing panels.

Multiwall polycarbonate panels (MWPC) 29 is the preferable roofing material as they possess a number of physical characteristics facilitating the MRRS. MWPC
25 panels are positioned on the top of the sections frame. They are fixed on/in the carrier profiles 12, 13, in the U profiles 18 on sliders and with the protective bar 20 at the middle purlin. Rubber seals must be used to prevent leakage from rain water (not shown).

Side wall 68 of the section 1 is optional.

The gap between the sliding sections securely covers the protective bar 19 which is fitted on the front carrier profile 12 on the sliding section 2 and 3.

The rigid section 4 has the same assembly principle with the only difference that the carrier profiles are fitted directly to the modified sliding channels 6, 7.

Fig.13, 14 show another important part of the MRRS which is a slider of the retractable section. The slider is made from rectangular profiles of 211cm in length with the ends closed by end caps 48. Each slider has two fixtures for the carrier profiles 28 and the U profile 18 attached to the internal side. Two pairs of V-grooved wheels 31 and nylon rollers 32 are fastened from the external side. They are divided on two pairs: one pair of the V-grooved wheel and the nylon roller positioned at the front side of the slider and another pair at the end. The distance between the V-grooved wheel and the nylon roller has to match the internal width of the sliding channel vertically and the width of the stacking bracket horizontally perfectly (Fig.15, 16).

Fig.13 (a-d) outlines the view of all sides of the fully fitted right slider of section 1. The retractable section 1 performs the driving function of the MRRS and is fitted with reversible geared motors 23. They are installed on the internal side of the sliders 14, 15, beside the front carrier profile 12. The slots for the motors pinions 30 on the bottom of sliders might have a slightly different position on the left side fig.13 (e) due to motor's design. V-grooved wheels on the section 1 have to slide only by the outside tracks 40 and positioned in a way that allows the section 1 to reach the end of the stacking frame and conveniently install the motors. The holders of the motors cable drag chain 34 have to be attached from the outside front side of the slider.

Fig.14 (a-d) shows the same overview for the slides of the retractable sections 2, 3. The nylon wheel 33 at the front corner and the second nylon wheel at the opposite side are positioned inside the slider and designed to provide smooth motion between retractable sections during the stacking process and in the stacking frame. The front V-grooved wheels 31 have extended axis to slide by the inside tracks 39. The back V-grooved wheels

31 have to be fixed at the corner to direct the section horizontally by the outside tracks 40 and vertically by the outside stacking brackets.

Fig.15, 16 illustrates the position of the wheels 31, 33, the nylon rollers 32 inside the channel 42, on the sliding tracks and inside the stacking brackets. Also, these figures
5 clearly demonstrate the tri-linear wheel system which is used for the stacking process.

Fig.17, 18 shows the left Z connectors 47. One of the Z connectors is fixed to the front side of the SN2/SN3 on the front carrier profile 12 and another is fixed to the back side of the SN1/SN2 on the back carrier profile 13, Fig.17. They are positioned in a way to interlock when the retractable sections are closing, Fig.18. Two pairs of Z connectors are
10 located on each side of the retractable sections.

Fig.19 demonstrates the back view of the right spur gear driving mechanism. The motor 23 is fixed to the internal side of the slider 14 so the pinion 30 is located inside the slider above gutter 43. The toothed racks 46 are hidden inside the gutter of the multifunctional sliding channel 5, providing a safe and reliable interaction with the pinion. One end of the
15 motor cable drag chain 45 is fixed to the bottom of the channel 42 between the side wall and inside track 39. The second end is fixed on the holder 34.

Fig.20 gives the front view of the right sliding channel with illustration on how the retractable sections are stacked. The section 1 is sitting in the sliding channel on the outside track 40. The section 2 is firmly stacked in the stacking brackets above section 1.

20 Fig.21, 22 show electrical components and their recommended position on the MRRS. The electrical control unit for a sliding gate can be used to operate the MRRS as it supports all required electrical functions:

- control reversible geared motors 23
- remote control 53
- 25 ▪ opening/closing manual switch 52
- opening/closing limit switches 49, 50
- rain sensor 54
- Over heat and blocking protection

The control unit is located in the waterproof box fixed at the bottom of the section 4 in the corner beside the middle purlin 27 and front carrier profile 12. The power supply cable of the motors should safely follow the motor during the opening/closing process. The cable drag chain 45 has been chosen for that purpose. The limits of the system operation are monitored by the opening 50 and closing 49 limit switches. Their recommended position is beside the inside elevating slopes 35 as it provides the most reliable operation. The final adjustment is required during installation, to ensure the right moment of a contact.

Two options are available to control the MRRS: the remote control 53 and the manual open/close switch installed in the house 52. The rain sensor 54 can be added to the system to provide automatic closing of the MRRS in the case of the rain.

Fig.23-28 demonstrates the stacking process of the MRRS. Begin with Fig.23 (a-d) which shows the right side view of the stacking frame and all stages of the closing process.

All sections are stacked in the stacking frame. Closing button is activated. SN1 is driven by motor 55 and starts moving by the outside tracks 40 in the sliding channel 42 away from the stacking frame. SN1 slides between SN4 and SN2, freeing space for the last one. Back V-grooved wheels 31 of SN2 are staying on top of the outside elevation slopes 36. The front nylon wheels 33 roll by top surface of the sliders 14, 15 SN1 to the end, where they slide down 58 until the front V-grooved wheels of SN2 reach the inside elevating slopes 35 (Fig.23b, and also Fig.24, 25).

Now, SN1 continues its motion 55 and SN2 starts sliding downwards 60 following the SN1 by the elevating slopes 35 and 36 under their own weight. At this point, the Z connectors 47 of the SN1 and SN2 are interlocking. The SN3 moves down vertically inside the stacking brackets taking the position of the SN2 (Fig.23c)

Interlocked SN1 and SN2 continue sliding 55 and the same procedure repeats between SN2 and SN3, after that, all retractable sections together follow to the end of the sliding channel 42, freeing SN4. Full stop command comes from the closing limit switch 49. The MRRS is fully closed when the back carrier profile 13 SN3 positioned above the front carrier profile 12 SN4.

Fig.24, 25 illustrate the key moment of the closing process in details.

SN1 is driven by motors 55 and rolls on V-grooved wheels 56 by the directional tracks 40 away off the stacking frame. The nylon wheels 33 of SN2 roll on top surface of the sliders SN1 to their end 57, where they roll down over the edge of end caps 48, changing the
5 horizontal rolling 57 into vertical 61. The front side of SN2 moves down until its front V-grooved wheels reach the inside elevating slopes 35.

Now, SN1 continues its motion 55 but SN2 starts downwards sliding 60 following SN1, rolling by the elevating slopes 59 under their own weight. The nylon wheels 33 of SN2 gradually roll downwards 61 by the surface of the end caps 48 of SN1, keeping right
10 distance between sections. At this point, the Z connectors 47 of SN1 and SN2 are interlocking. The same procedure repeats between SN2 and SN3

Fig.26-28 illustrate the key moment of the opening process in details.

All sections are positioned along the sliding channels covering the entire territory. By
15 activating the opening button on the remote control/manual switch, SN1 starts pushing 55 SN2 and SN3 towards the stacking frame. The end caps 48 on the back side of the sliders SN2/SN1 rest against the nylon wheels 33 fitted at the front corners of the sliders SN3/SN2. V-grooved wheels 31 roll 56 by the tracks 40, 39 respectively, until all V-grooved wheels of SN3 simultaneously reach the elevating slopes 35, 36.

20 Now, (Fig.26, 27) the horizontal motion SN3 55 is redirected upwards 60 by the elevating slopes. SN1 and SN2 continues pushing 55 SN3 which V-grooved wheels 33 smoothly roll upwards 59 by the elevating slopes and at the same time, the nylon wheels 33 gradually roll vertically up 61 by the surface of the end caps 48.

Finally, all V-grooved wheels 31 have reached the top ends of the elevating slopes
25 (Fig.28), but because the inside elevating slopes 35 are shorter than the outside elevating slopes 36, the front nylon wheels 33 SN3 have just passed approximately 2/3 of their diameter. Under the force of translational motion 55 they roll over the edge of the end caps 48 on top of the sliders SN2 changing vertical rolling 61 into horizontal 57 and slightly lifting the front side of the SN3 vertically up 58. The directional guides 37 are
30 directing the nylon rollers 32, ensuring the right sequence, when upward sliding 60 have to be completed first, before vertical lifting 58.

As a result, nylon rollers 32 are moved up and securely fixing SN3 inside the stacking brackets 8 and 9, preventing backwards sliding.

SN1 continues motion 55 pushing the SN2 between SN3 and SN4 towards the stacking frame's end, until all V-grooved wheels of SN2 simultaneously reach elevating slopes. The
5 back V-grooved wheels of SN3 stay on the top of the outside elevating slopes, while its nylon wheels 33 are rolling 66 by top surfaces of the sliders SN2.

The same stacking procedure repeats between SN2 and SN1 with the only difference that SN3 is lifted the inside of the stacking brackets up. The smooth motion between SN3 and SN2 provides two front and two back nylon wheels 33.

10 Finally, SN1 slides to the end of the stacking frame between SN2 and SN4, bypassing all elevating slopes. The full stop command to the motors comes from the opening limit switch 50. The MRRS is fully opened.

The rigid frame

The supporting frame, together with the stacking frame, creates a rigid structure around
15 the perimeter of the covering area. Only the frame of the MRRS provides a link with the ground and has to be securely fastened. Accordingly to the design, a few frames can be joined together allowing coverage of larger areas. Such construction might require additional supporting beams to increase rigidity. The rigid section as a part of the stacking frame can be replaced with another rigid structure (sunroom, house and etc.) having the
20 same roof shape. The size and shape of the multifunctional sliding channel can vary due to technical/design requirements. Additional sliding tracks also can be inserted for a larger MRRS. The elevating slopes of the stacking frame are positioned along sliding tracks with the distance between them which exactly match the distance between the V-grooved wheels on the sliders of the retractable sections. The stacking brackets are
25 attached on top of the modified multifunctional sliding channels above the top ends of the elevating slopes and designed to direct and securely hold the retractable sections in the opened position of the MRRS and during the stacking process.

Retractable section

Retractable section consists of two parallel sliders, minimum two carrier profiles and the required number of purlins and roofing panels. There is no specific shape or size for the profiles used in the retractable sections. Carrier profiles can be attached to the sliders
5 under an angle 0-45° which allows the creation of the following shapes of the roof: an arch, a flat, a triangle, a slope and many other variations. The first retractable section can be fitted with a side wall 68. Types and sizes of wheels and rollers fixed on the sliders have to be chosen accordingly to the physical characteristics required for the system operation. It is very important that their position exactly matches the positions of the
10 directional tracks and the elevating slopes that operate the tri-linear wheel system.

Driving mechanism

The MRRS operates by moving retractable sections between two parallel sliding channels. Chosen reversible geared motors should have optimal parameters (AC/DC, power and torque) required for the MRRS operation. They are installed on the internal side of the
15 sliders SN1, beside the front carrier profile. By design, the sliders are positioned above the gutter of the multifunctional sliding channel. This provides drop free gathering of the rainwater and a safe alternative to place the pinion and toothed racks. The pinions, hidden inside the sliders, interact with the toothed racks which are fixed inside the gutter. The control unit of the MRRS should provide control over the motors, limit switches,
20 remote control, manual switch and rain sensor if installed.

Operational principle

The tri-linear wheel system is an innovative stacking principle specially designed for the MRRS operation. The first line operates with the front V-grooved wheels 31, the inside sliding track 39, the inside elevating slopes 35 and the inside stacking brackets 8, 9. The
25 second line operates with the back V-grooved wheels 31, the outside sliding track 40, the outside elevating slopes 36 and the outside stacking brackets 10, 11. The third line facilitates the stacking process through the nylon wheels 33 and sliders 14-17. The first two lines provide the sliding function and simultaneous smooth movement of the retractable sections up/down by the elevating slopes. The third line provides free

movement of the retractable sections between each other in the stacking frame and smooth redirection of vertical movement to horizontal movement and vice versa during the stacking process ensuring unceasing motion.

- While the invention has been described herein with reference to several especially preferred embodiments, these embodiments have been presented by way of example only, and not to limit the scope of the invention. Additional embodiments thereof will be obvious to those skilled in the art having the benefit of this detailed description, especially to meet specific requirements or conditions. Further modifications are also possible in alternative embodiments without departing from the inventive concept.
- 10 The invention is not limited to the embodiments hereinbefore described but may be varied in both construction and detail.

Claims

1. A motorised retractable roofing system for use as an outdoor multifunctional structure/shelter comprising:
 - 5 a pair of multifunctional sliding channels positioned parallel from both sides of a covering area creating a supporting frame which is coupled into a single rigid structure with
 - a stacking frame positioned on the front or/and back sides of the system and comprising a rigid section, elevating slopes and stacking brackets operating with a tri-linear wheel system,
 - 10 required number of retractable sections to cover entire territory and where each section is equipped with a pair of sliders fitted with wheels and rollers representing a tri-linear wheel system which is applied for the sliding and stacking process, providing unceasing motion and convenient stacking of sections on the top of each other,
 - 15 a driving mechanism fitted in the way that the first retractable section performs the function of a locomotive pushing other retractable sections when opening and pulling them when closing.

2. A motorised retractable roofing system as claimed in the claim 1 wherein a multifunctional sliding channel comprises a channel with directional tracks (minimum 20 two), a gutter and a supporting profile (if required), in the way to:
 - support, direct and securely hold retractable sections,
 - provide convenient opportunity to fix mount brackets and elements of a driving mechanism,
 - 25 require minimum modifications to fit a rigid section and other elements of a stacking frame – elevating slopes and stacking brackets,
 - gather all rain water.

3. A motorised retractable roofing system as claimed in any preceding claim wherein a stacking frame comprises:
 - 30

a rigid section fixed directly to the multifunctional sliding channels modified for a stacking process,

two pairs of elevating slopes integrated along directional tracks and designed to provide smooth simultaneous up/down movements of retractable sections during stacking process, and

5

two pairs of staking brackets attached on the top of the modified multifunctional sliding channels above elevating slopes and designed to securely fix stacked retractable sections.

- 10 4. A motorised retractable roofing system as claimed in any preceding claim wherein retractable sections are equipped with a pair of sliders fitted with wheels and rollers creating a tri-linear wheel system and where:

lines one and two operate with directional tracks, elevating slopes, stacking brackets and grooved wheels providing correct direction in the sliding channels and simultaneous smooth movement of the retractable sections up/down by elevating slopes,

15

the third line comprises wheels positioned inside of the sliders which interact with the back and/or top surface of sliders providing smooth redirection of vertical motion into horizontal motion and vice versa during the stacking process and facilitating free movement of retractable sections on top of each other in the stacking frame.

20

5. A motorised retractable roofing system as claimed in any preceding claim which is fitted with a driving mechanism comprising a pair of reversible geared motors, spur/chain/belt gear and electrical components which operate in the way wherein the first retractable section performs function of a locomotive:

25

pushing other retractable section by the directional tracks and elevating slopes upwards and stacking them on top of each other during the opening process, and

30

pulling these retractable sections away from the stacking frame during the closing process

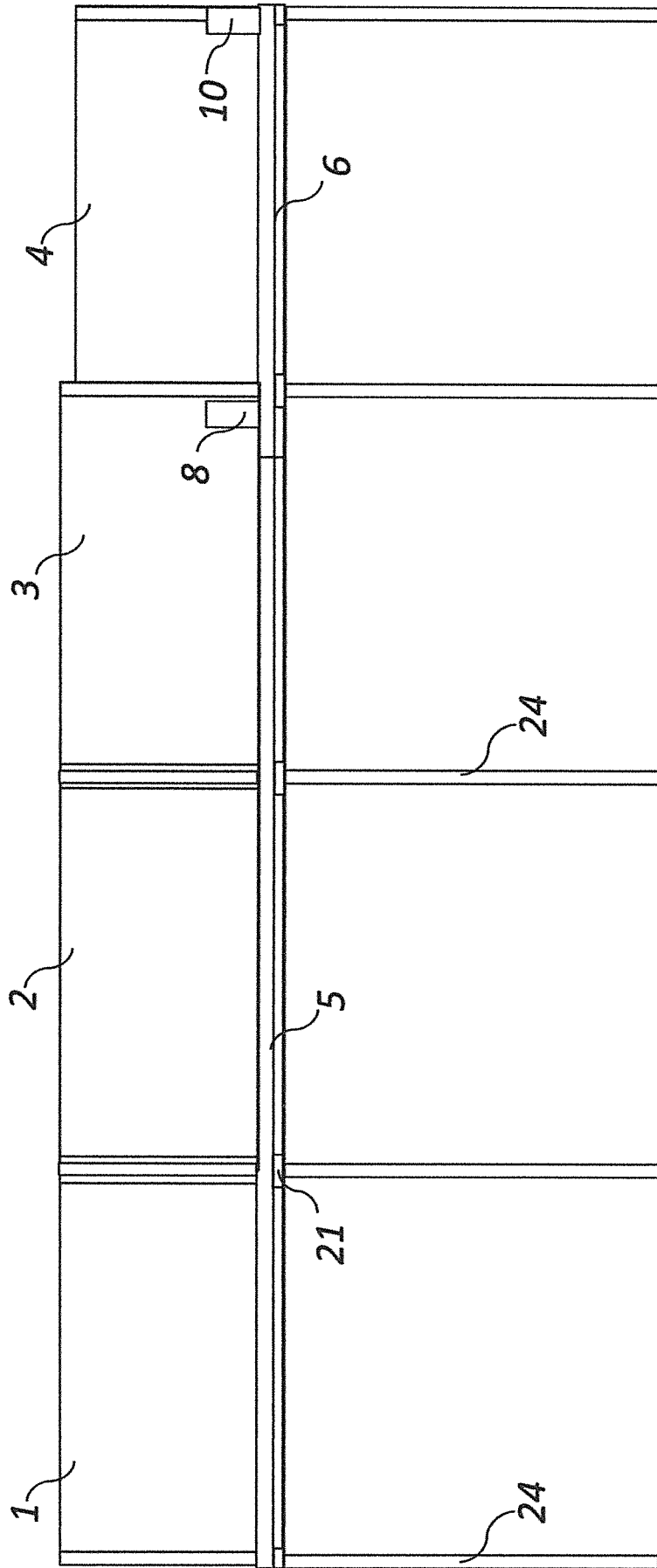

Fig. 1

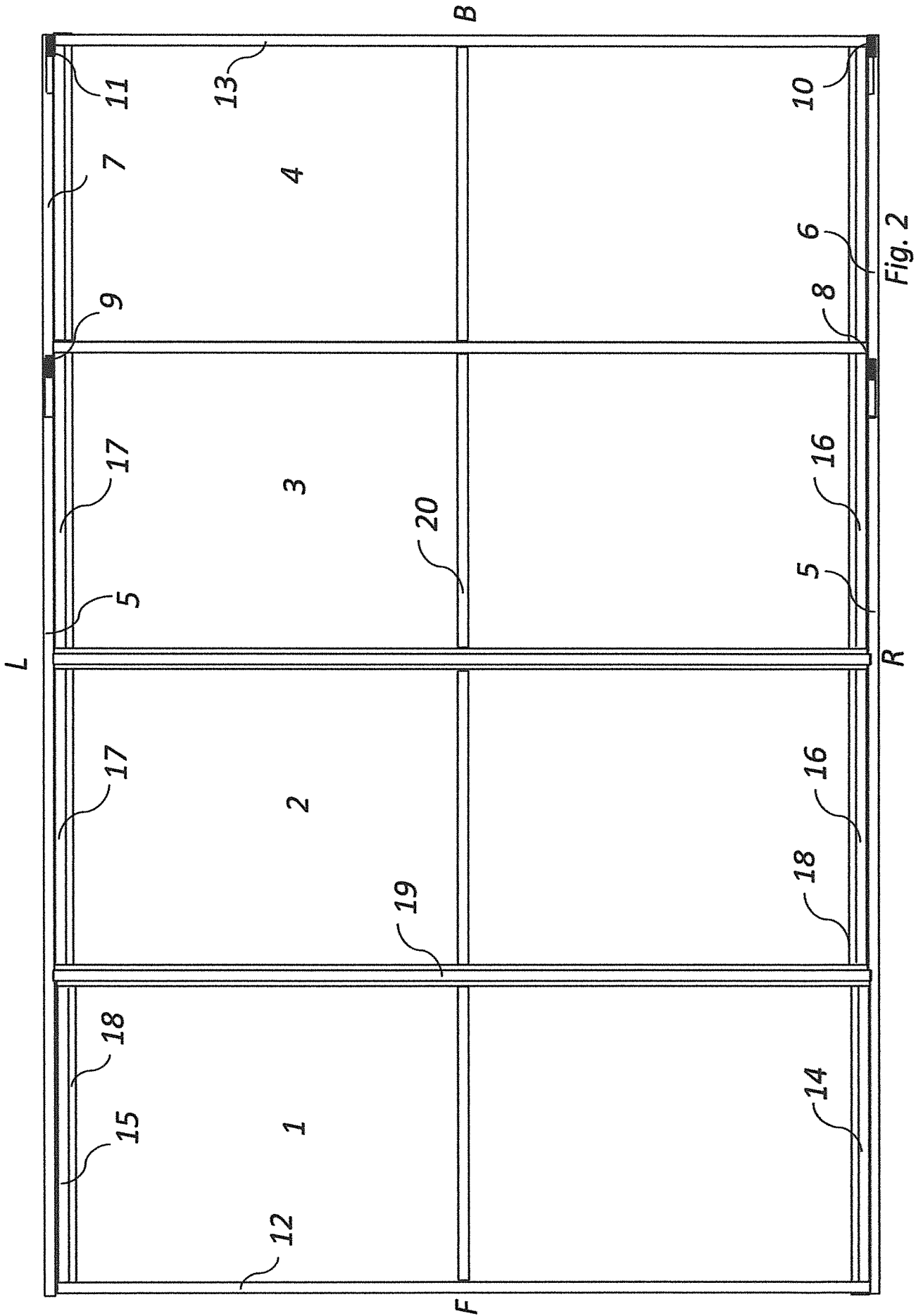

Fig. 2

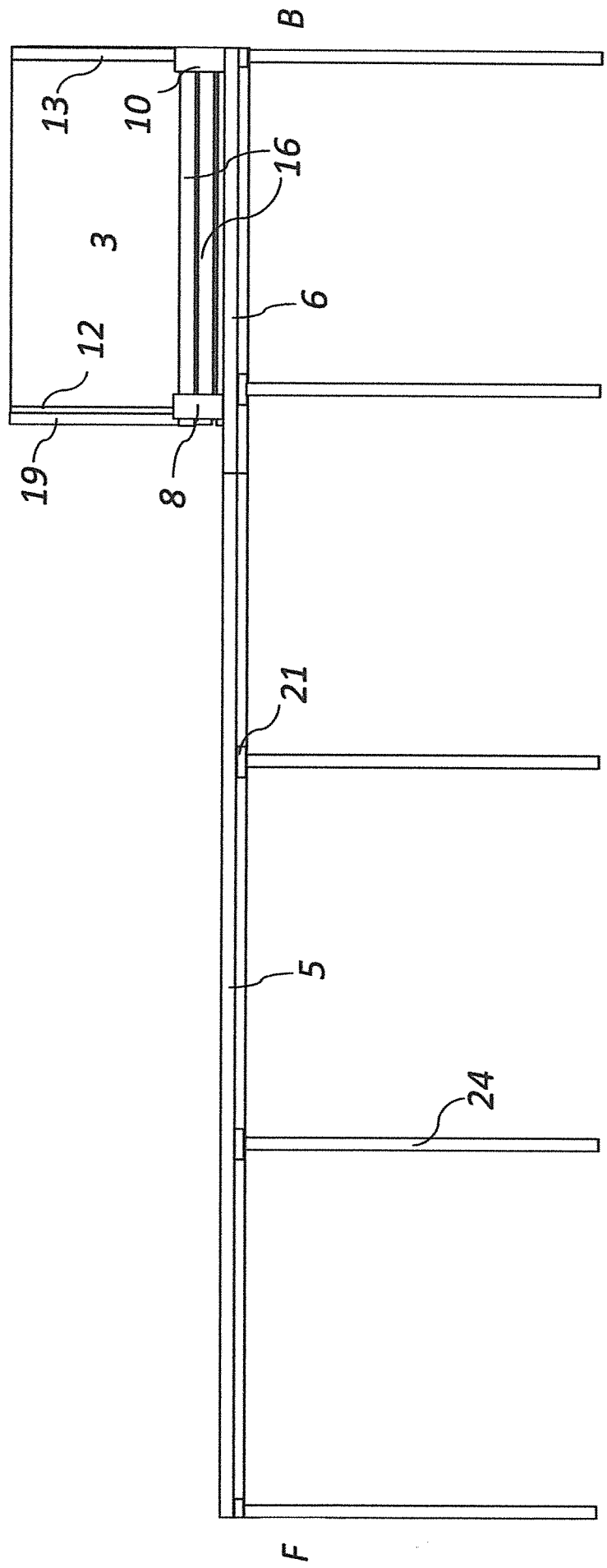

Fig.4

B

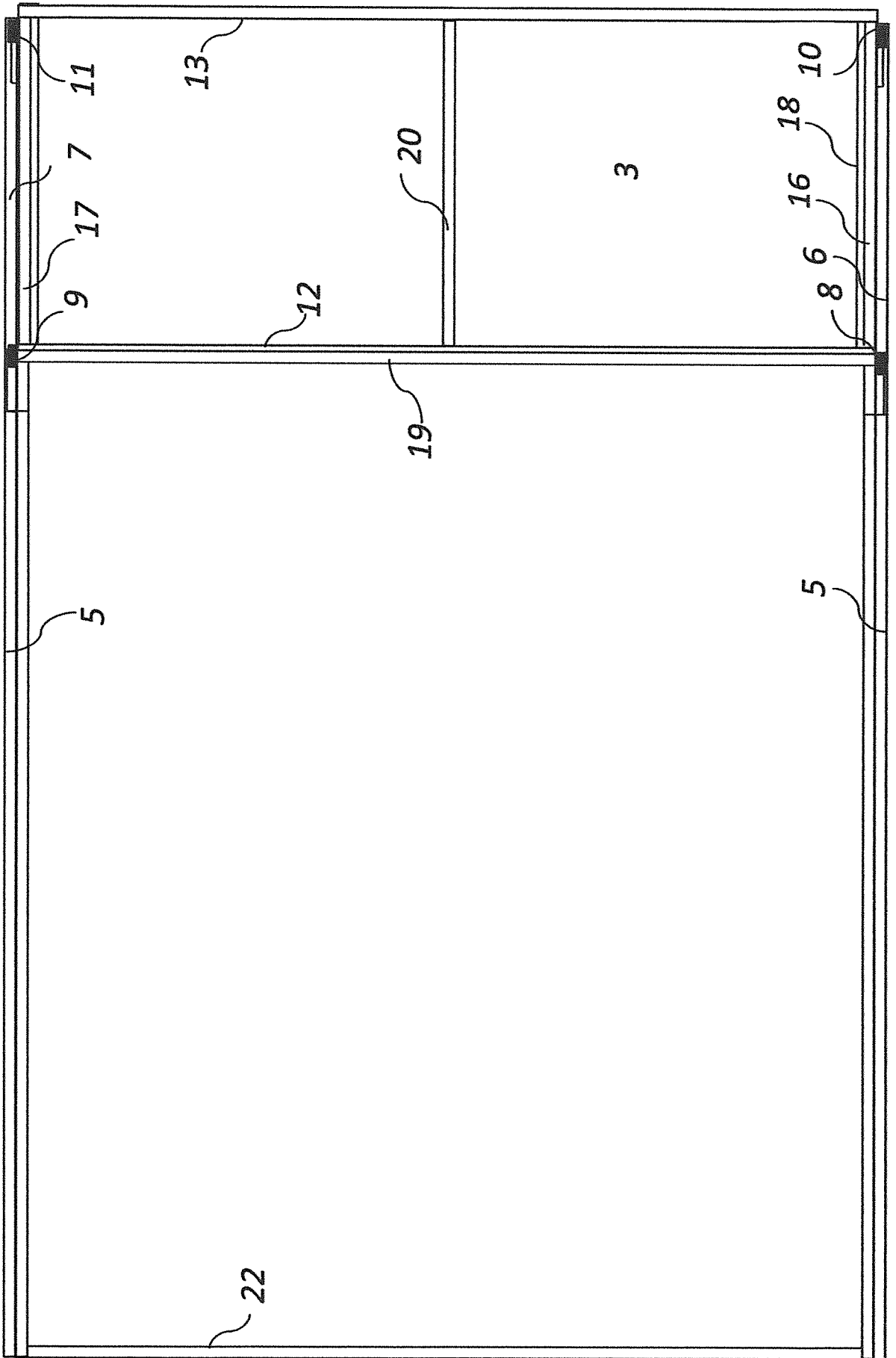

Fig. 5

F

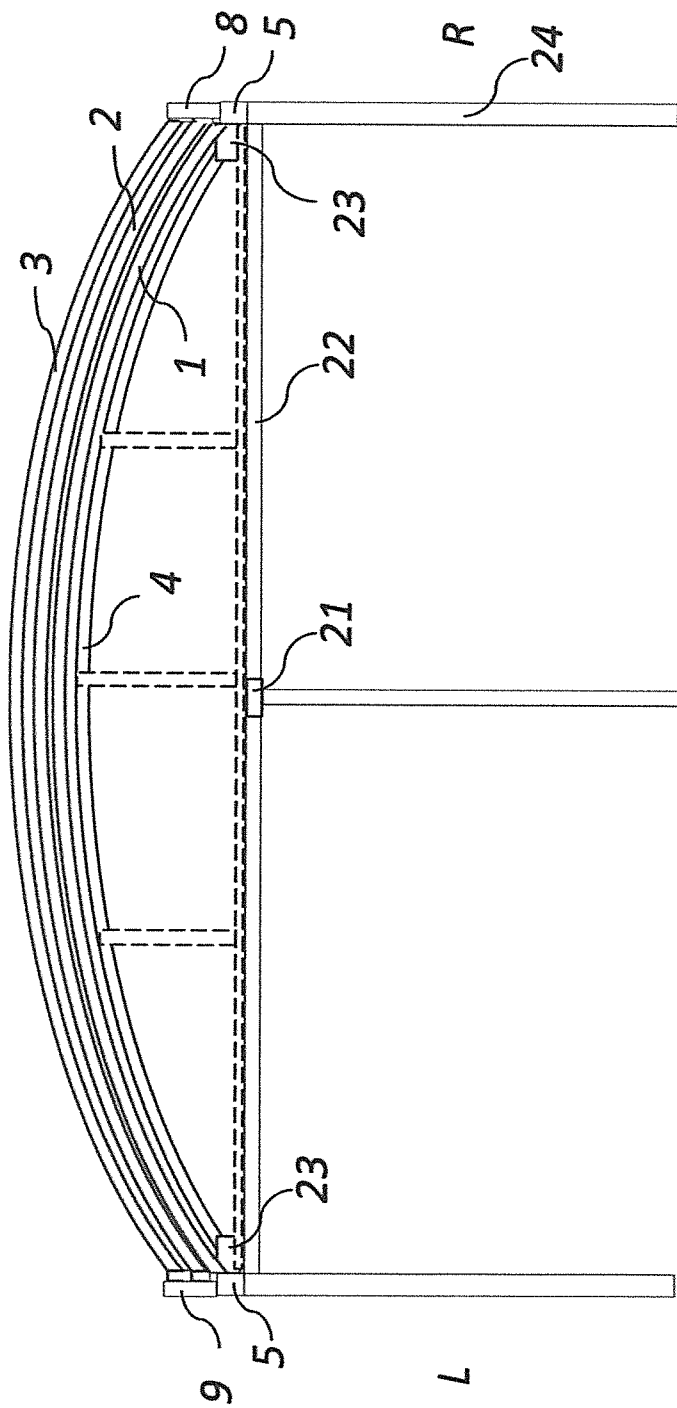

Fig. 6

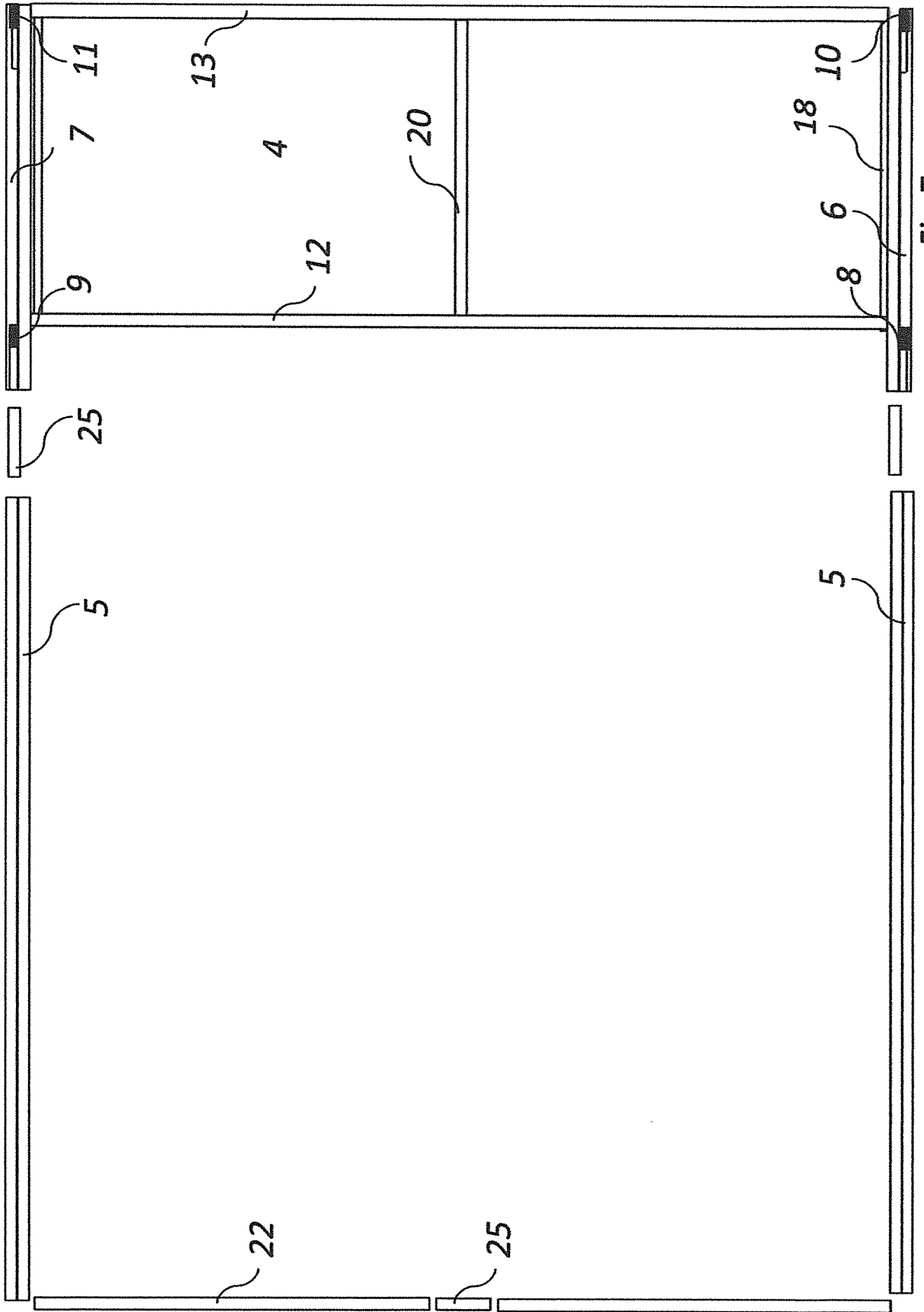

Fig. 7

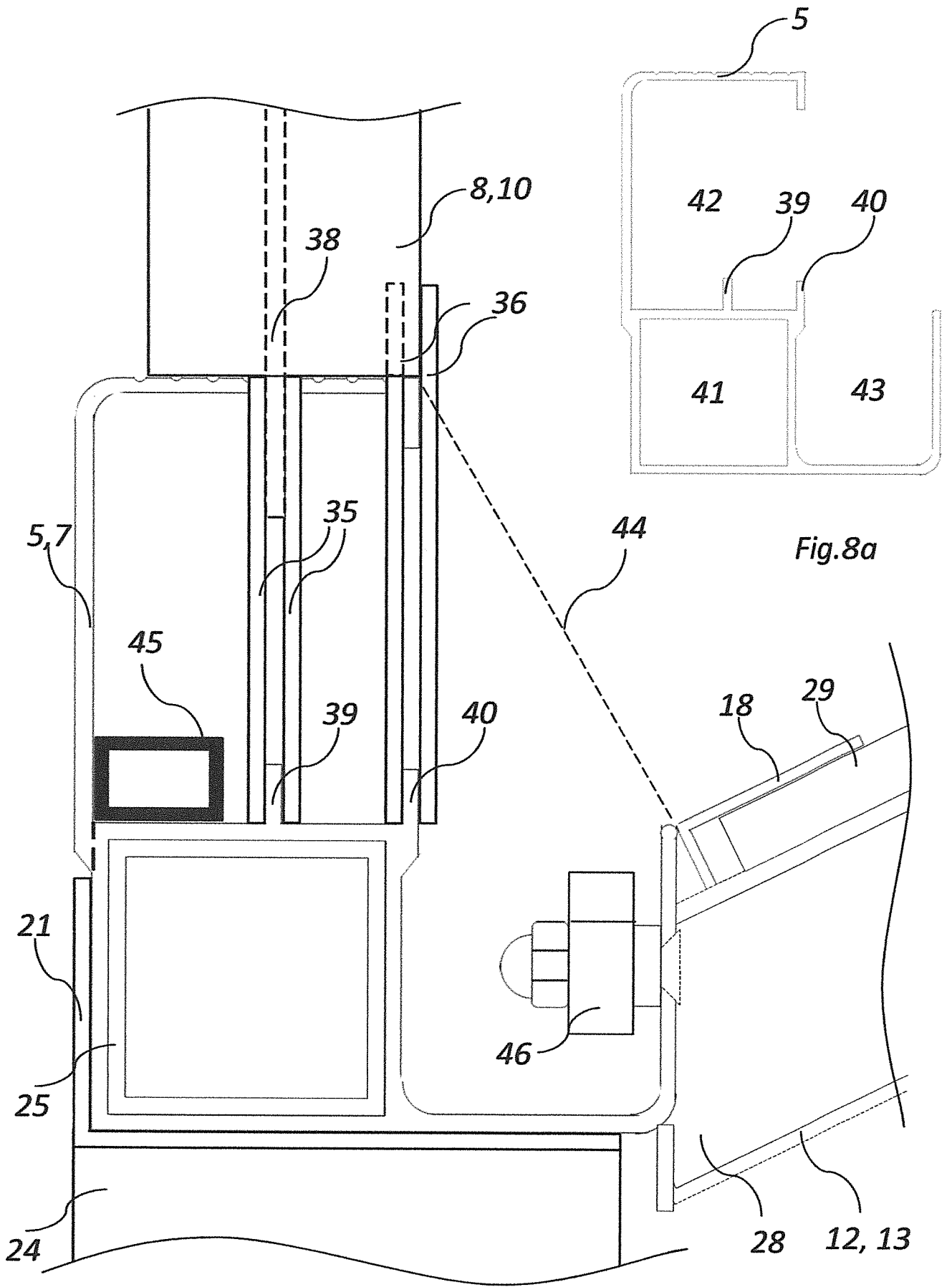

Fig.8a

Fig.8b

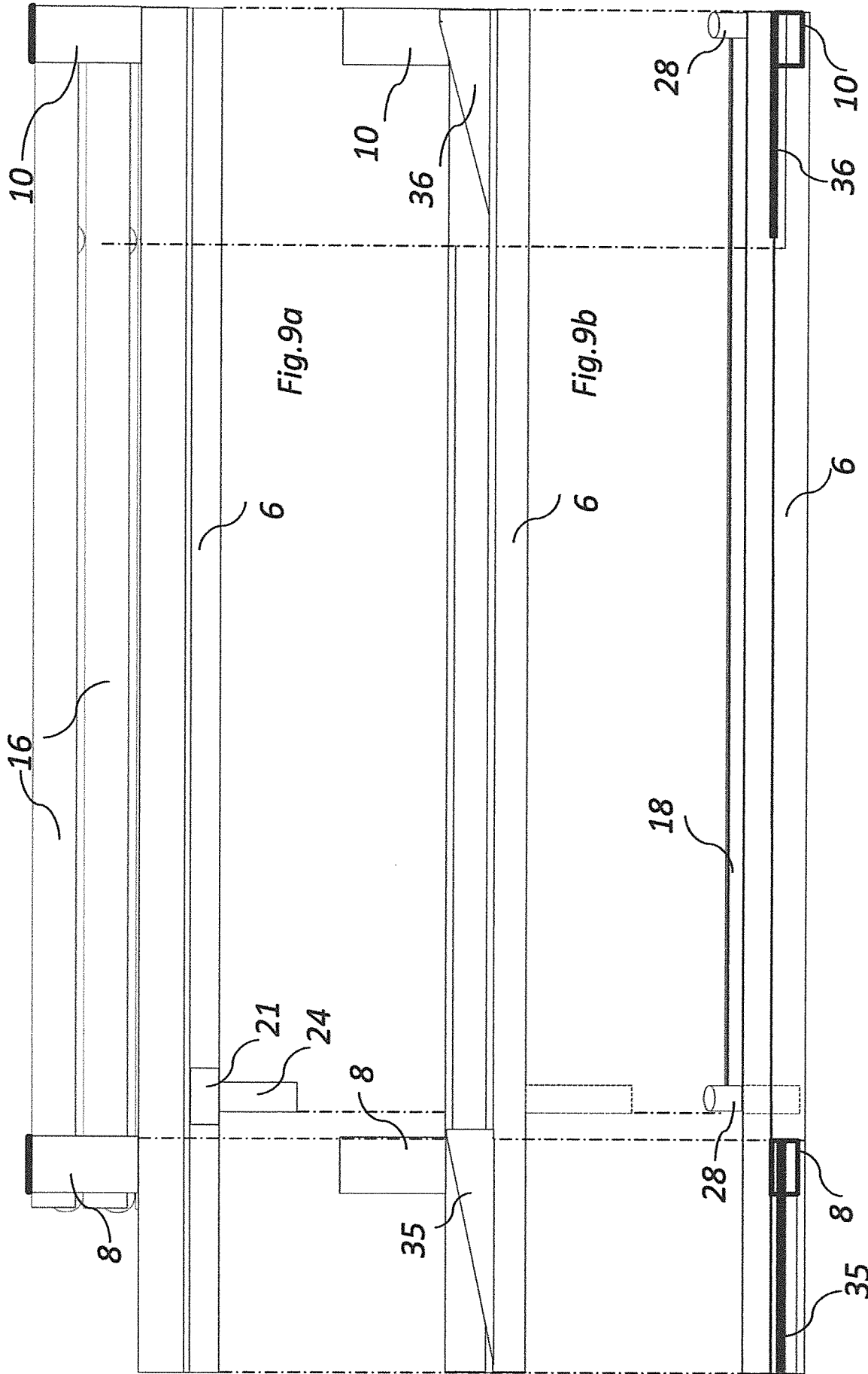

Fig. 9c

Fig. 9b

Fig. 9a

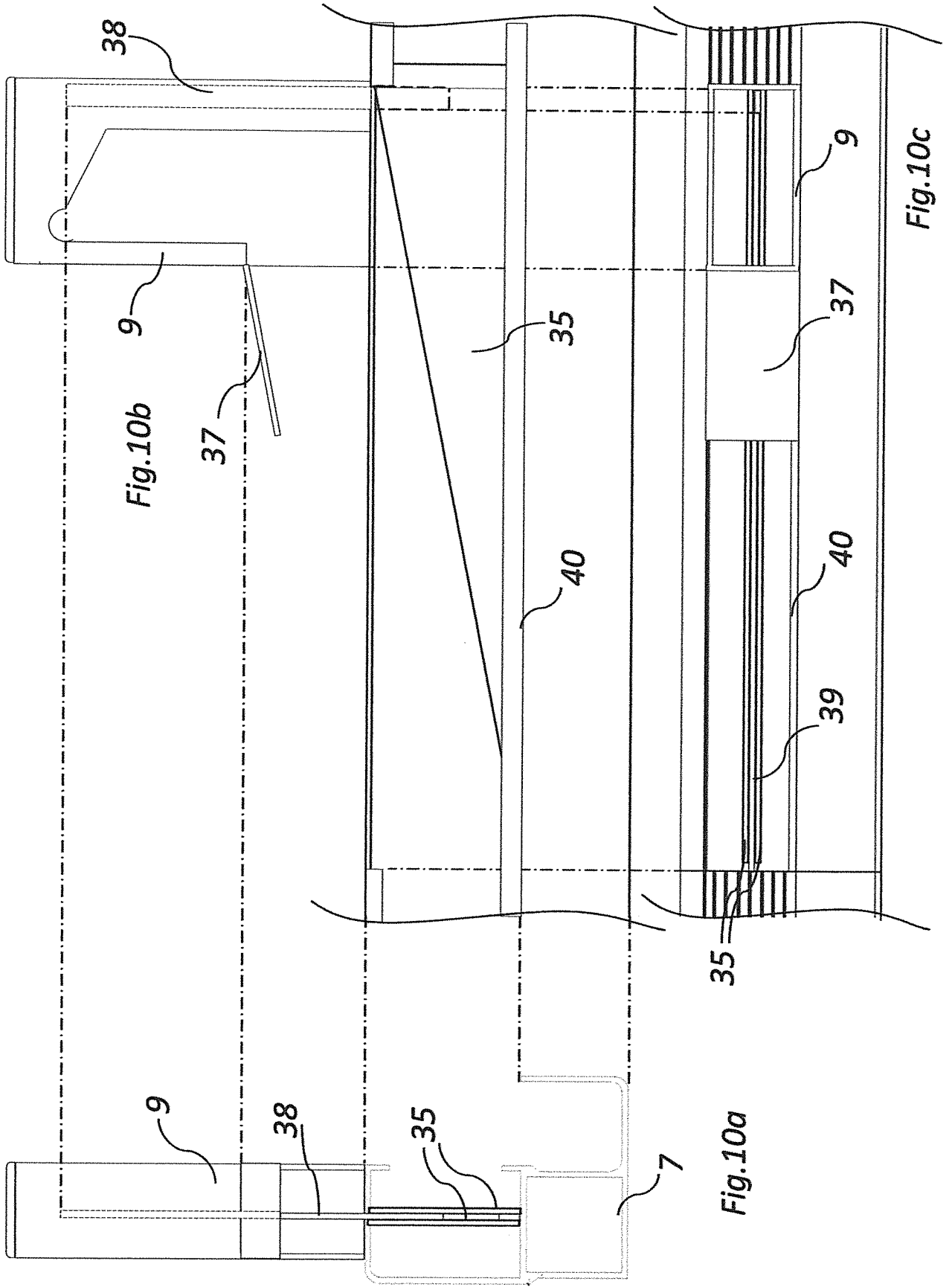

Fig. 10b

Fig. 10a

Fig. 10c

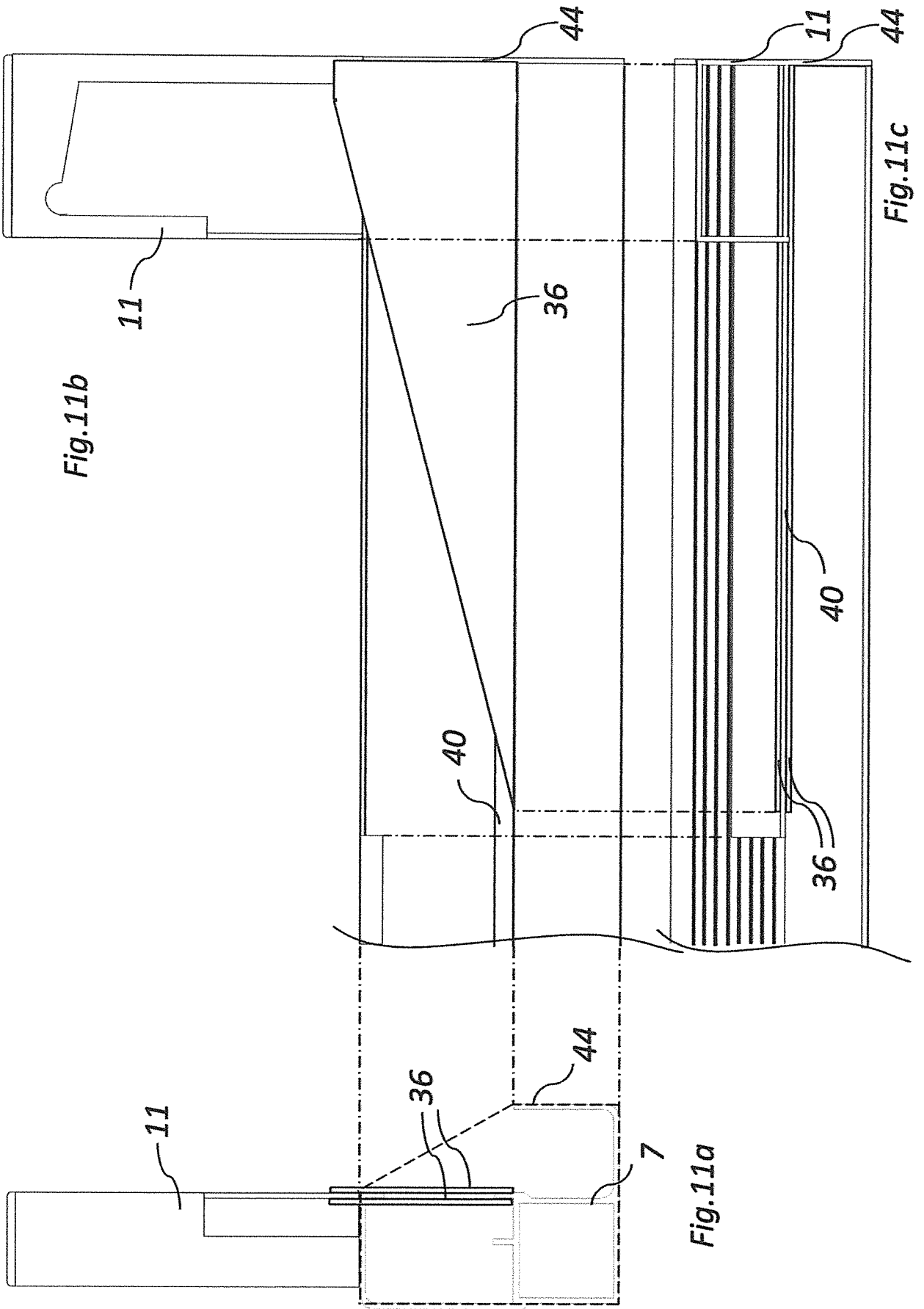
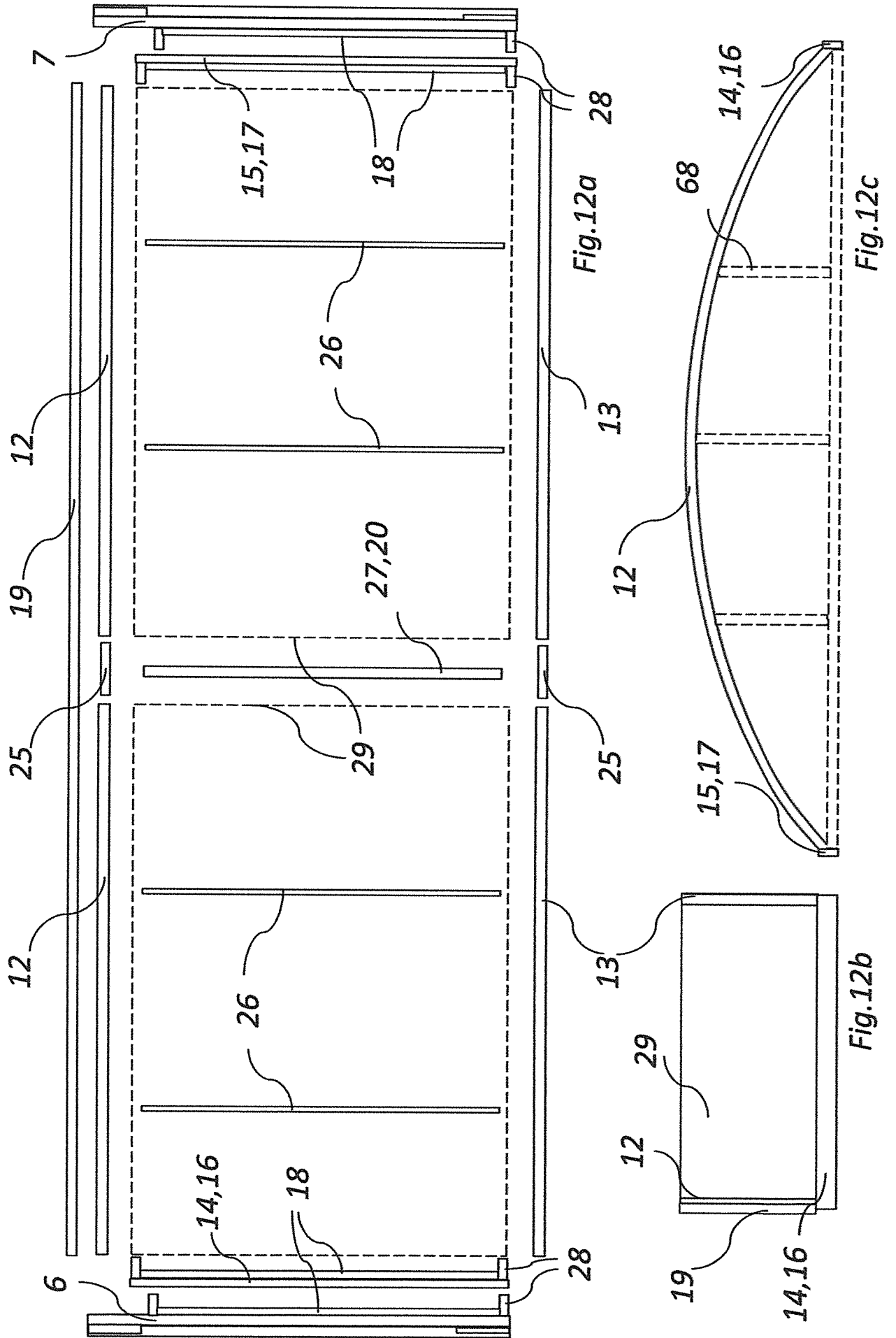
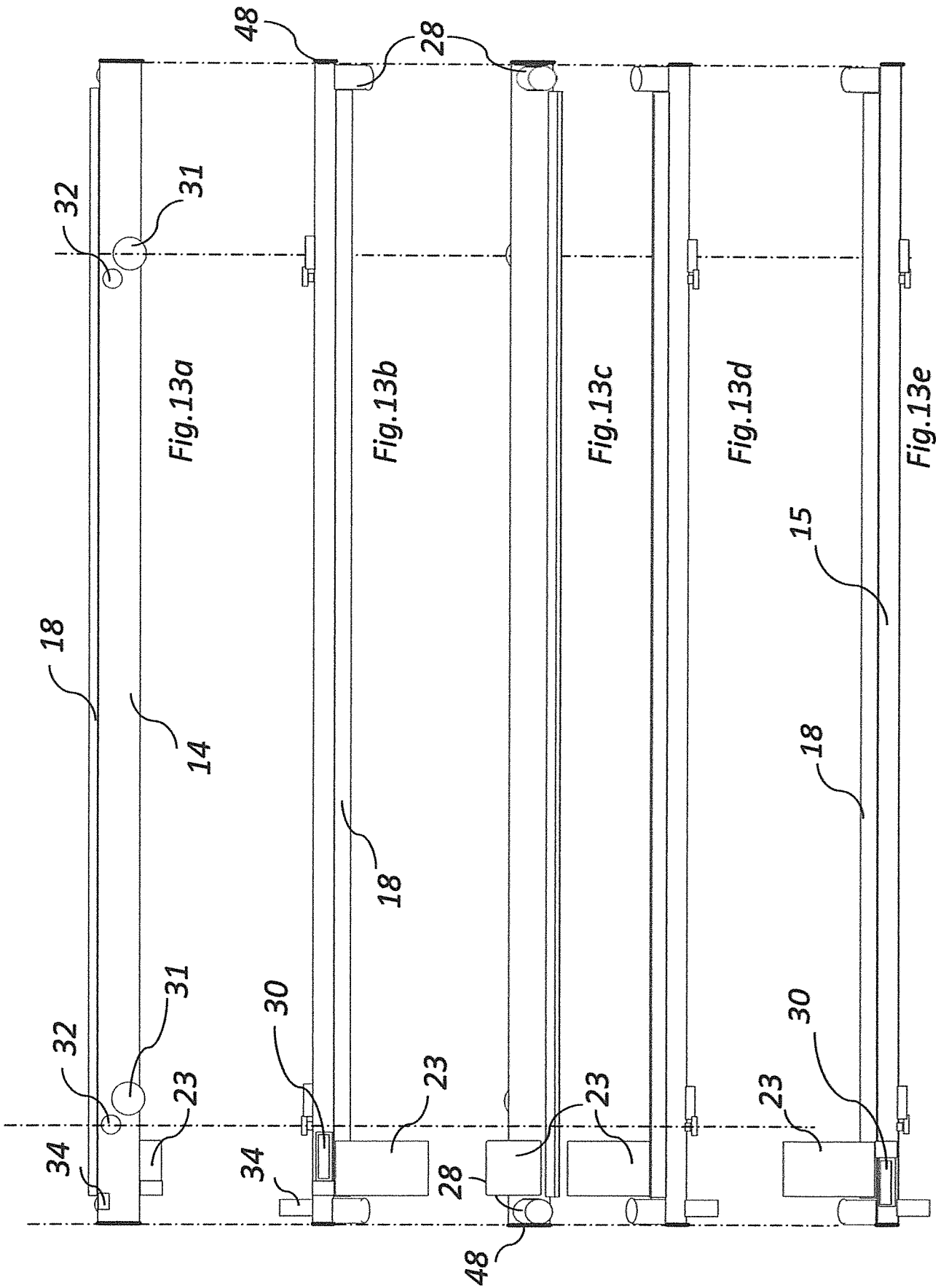

Fig. 11b

Fig. 11a

Fig. 11c





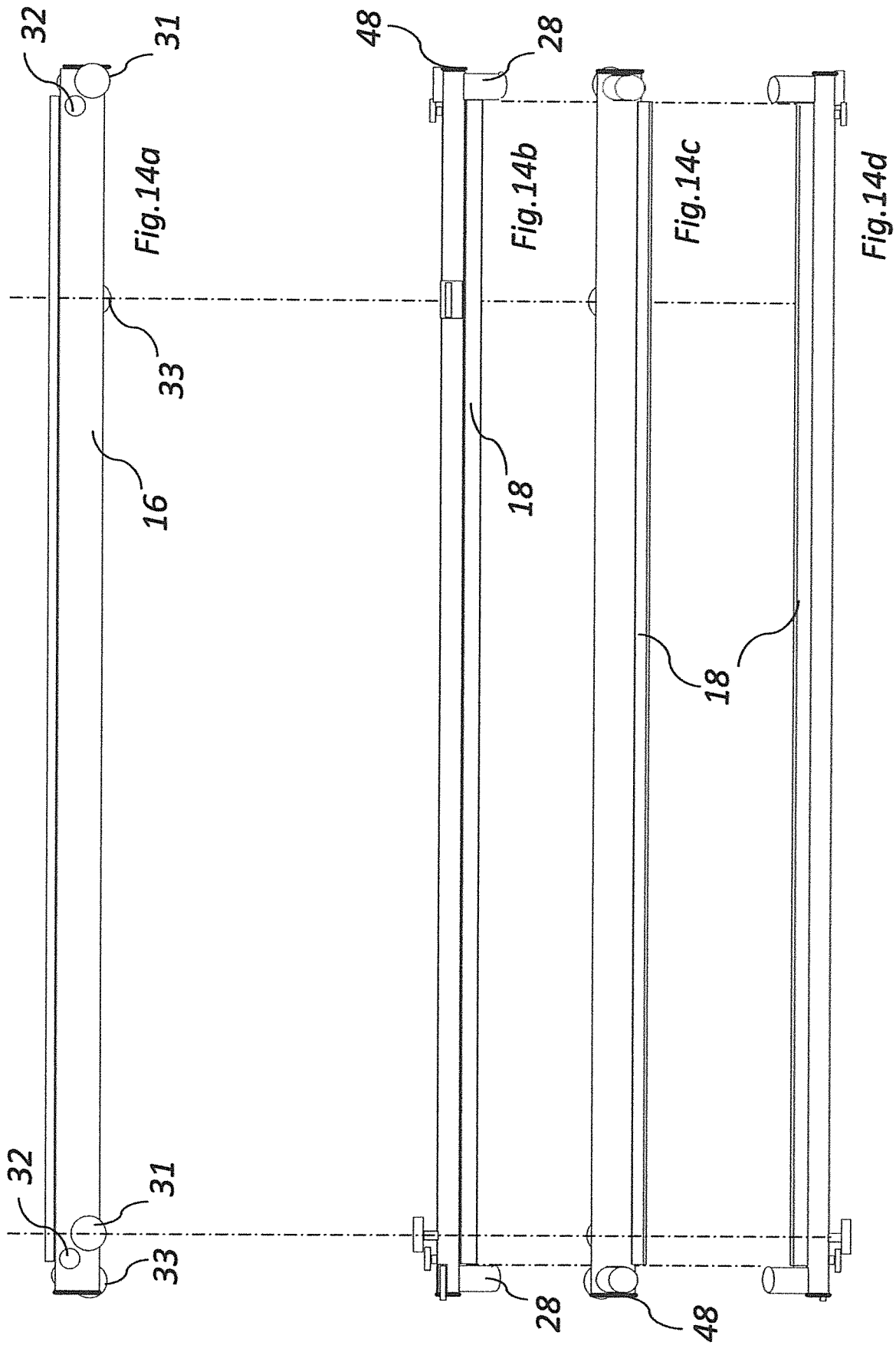

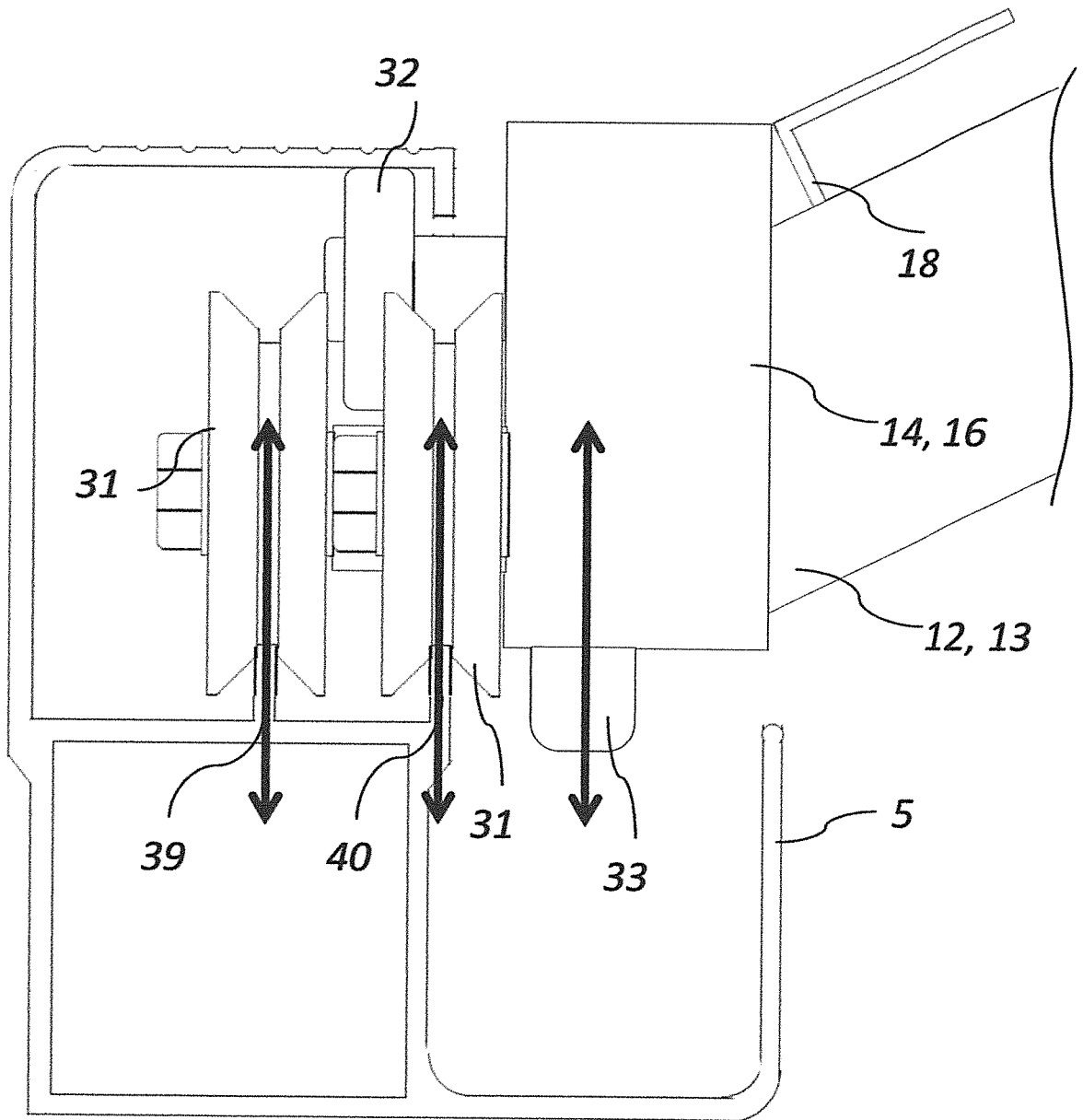

Fig. 15

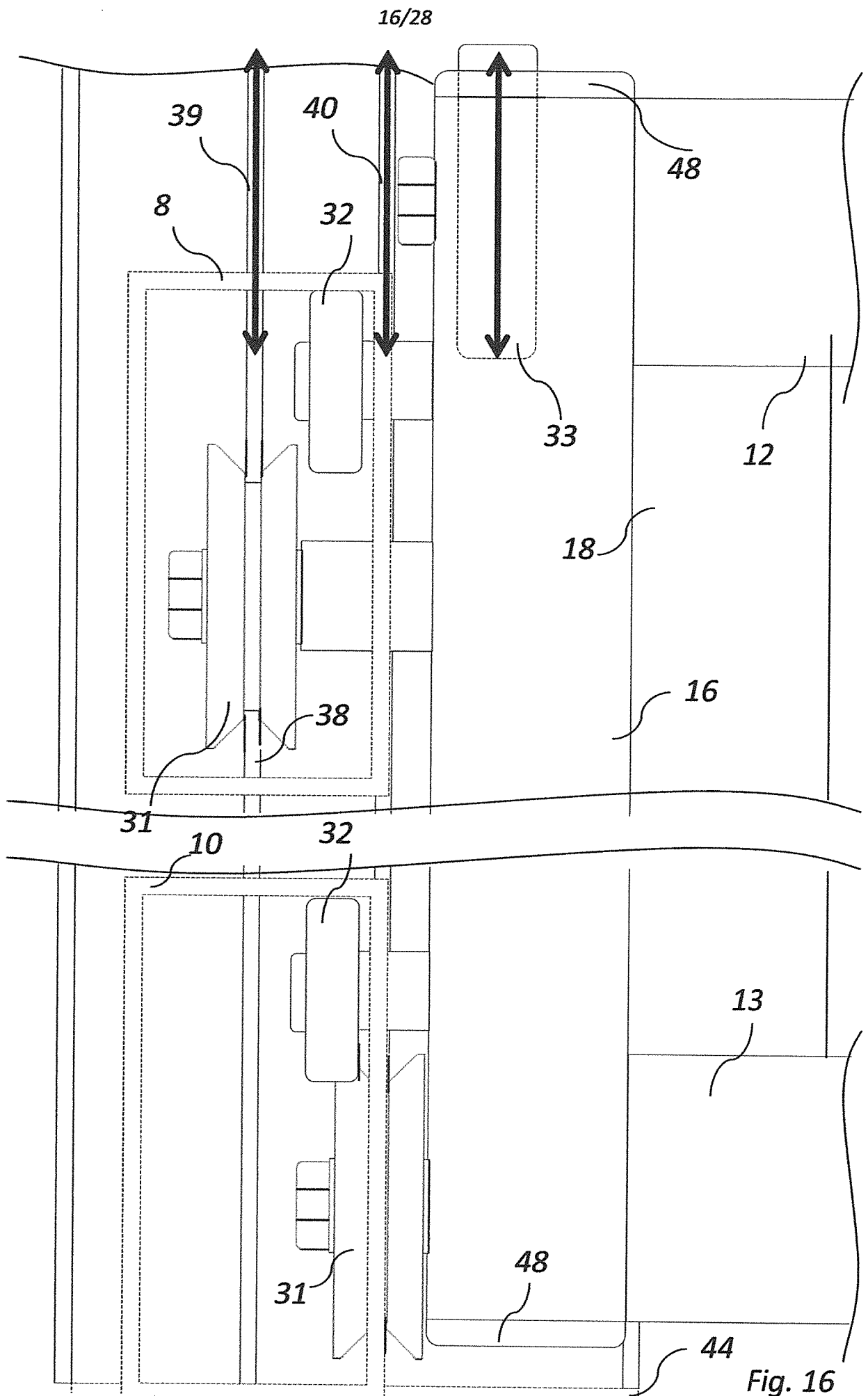

Fig. 16

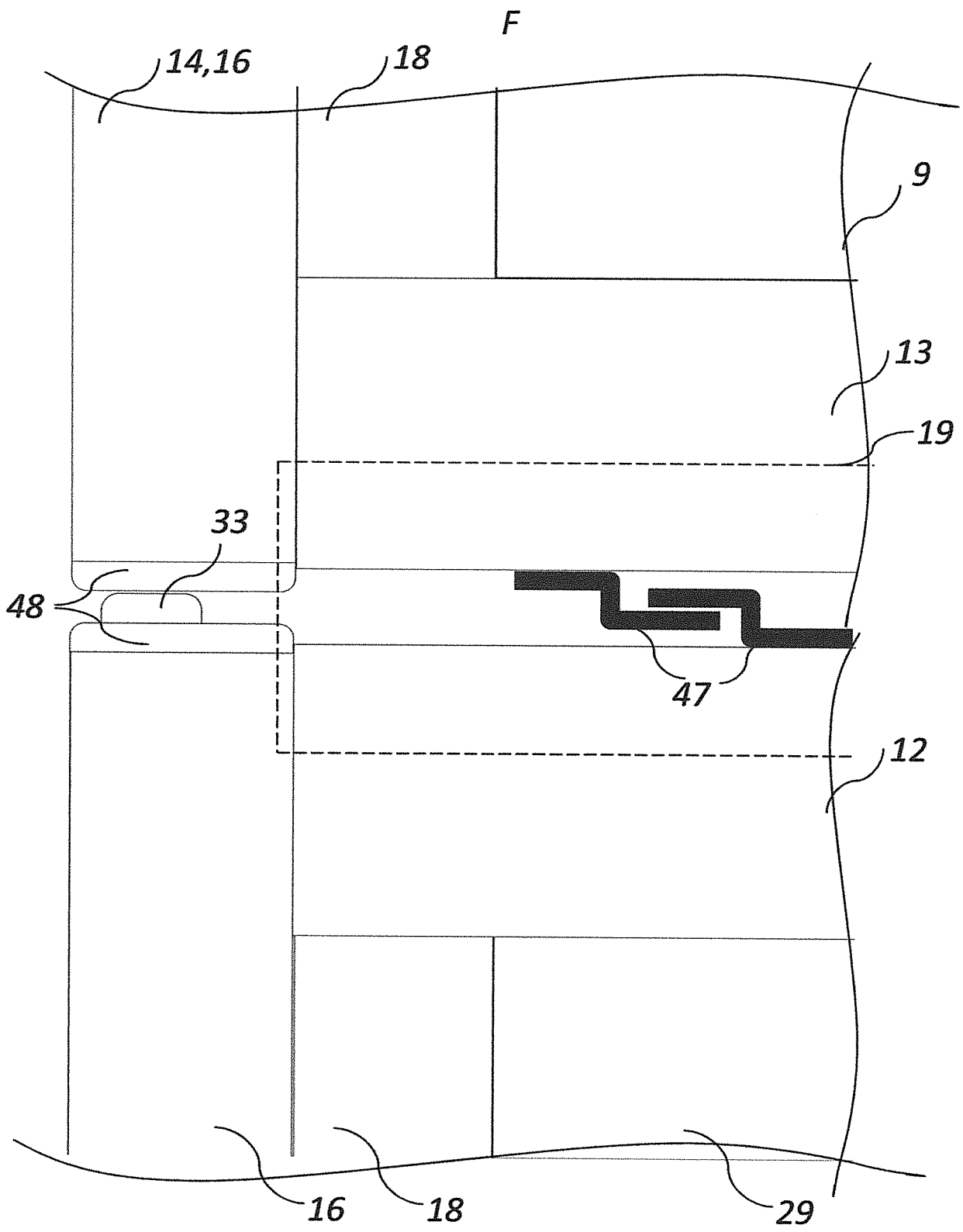
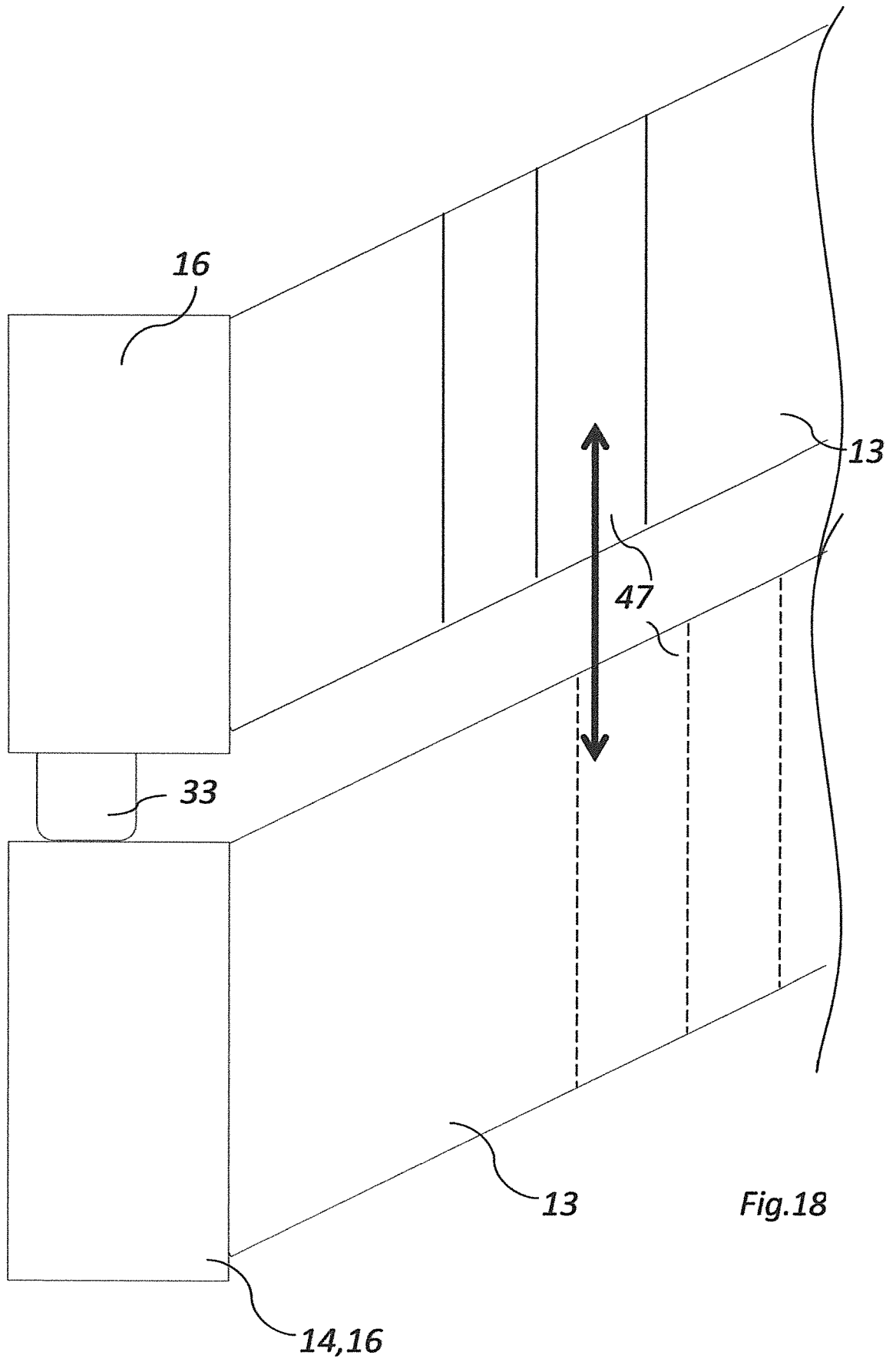

Fig.17



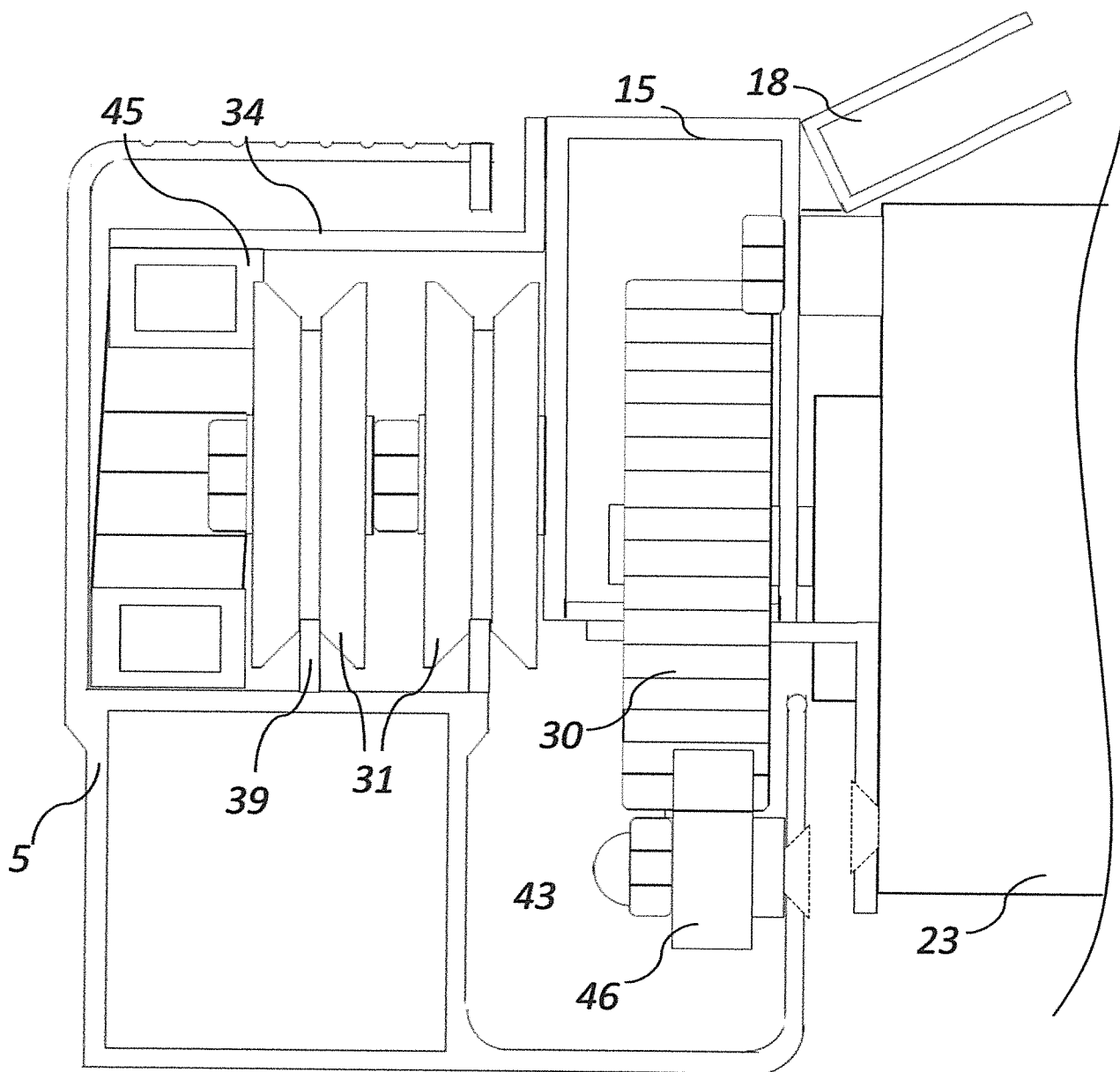

Fig.19

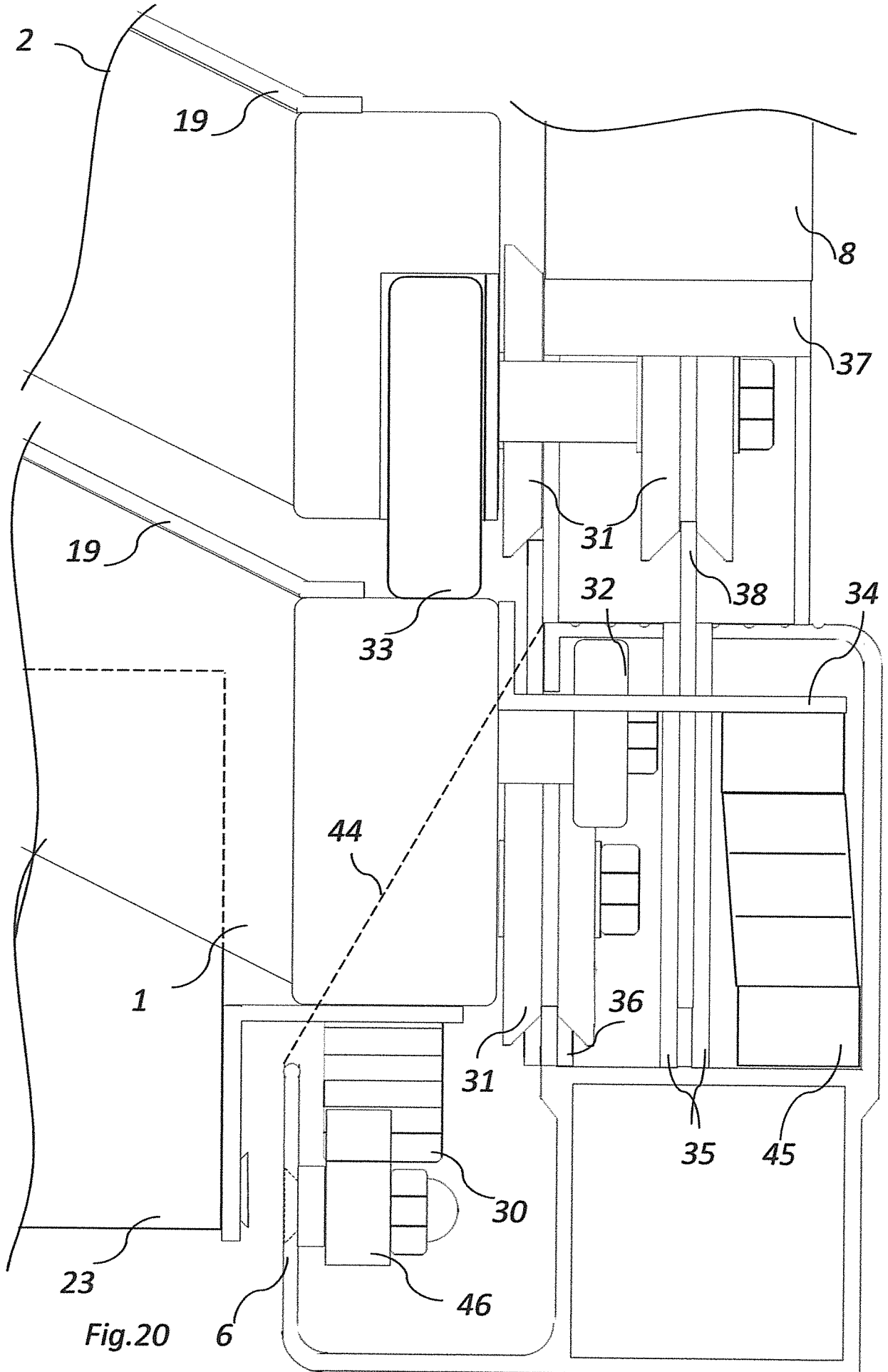

Fig. 20

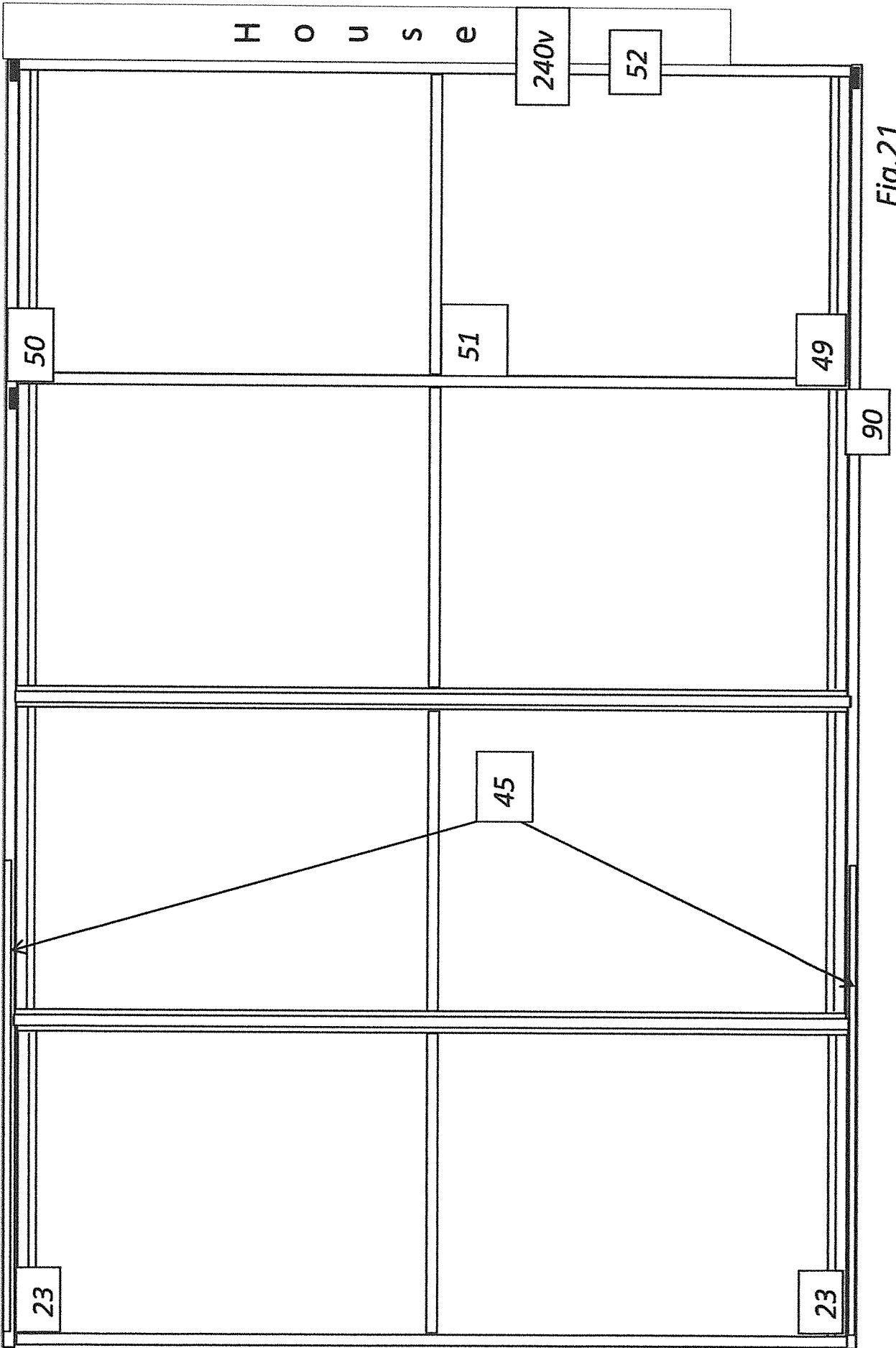

Fig.21

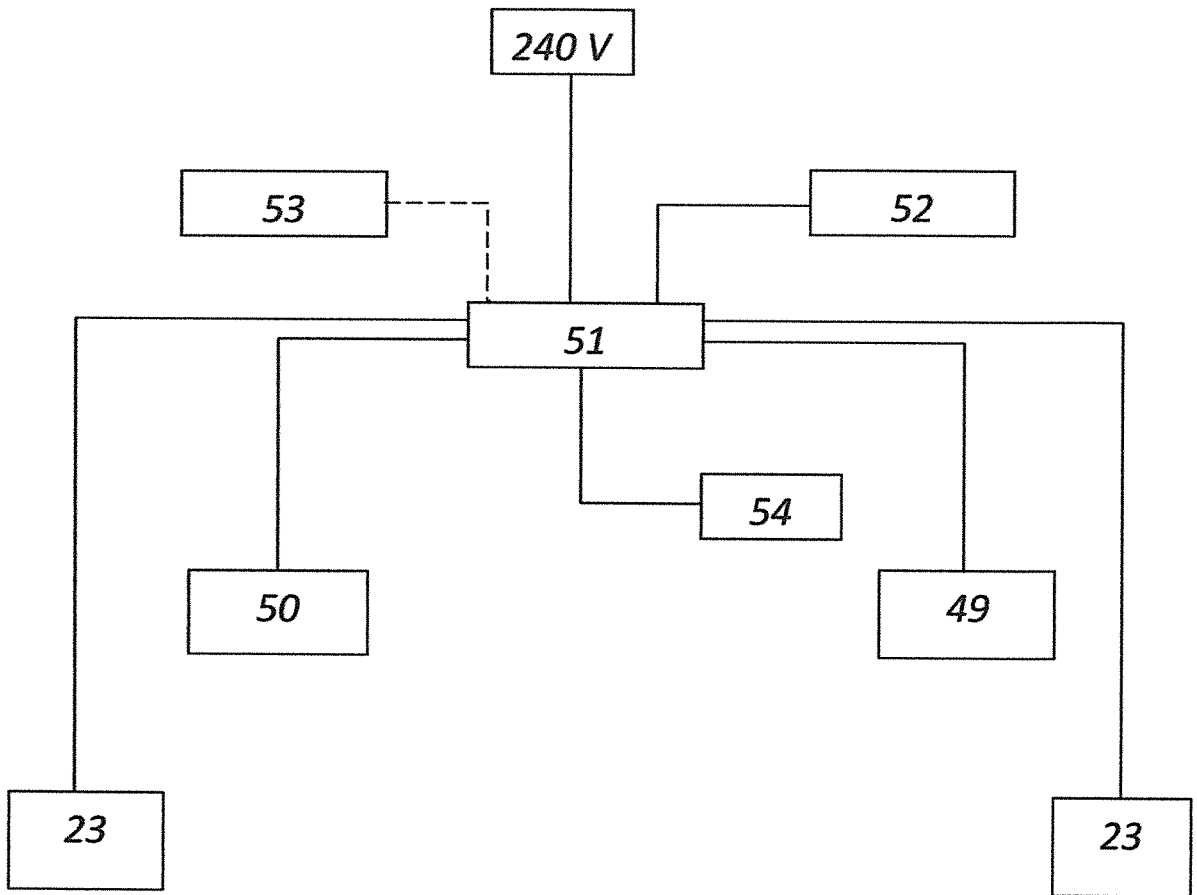

Fig.22

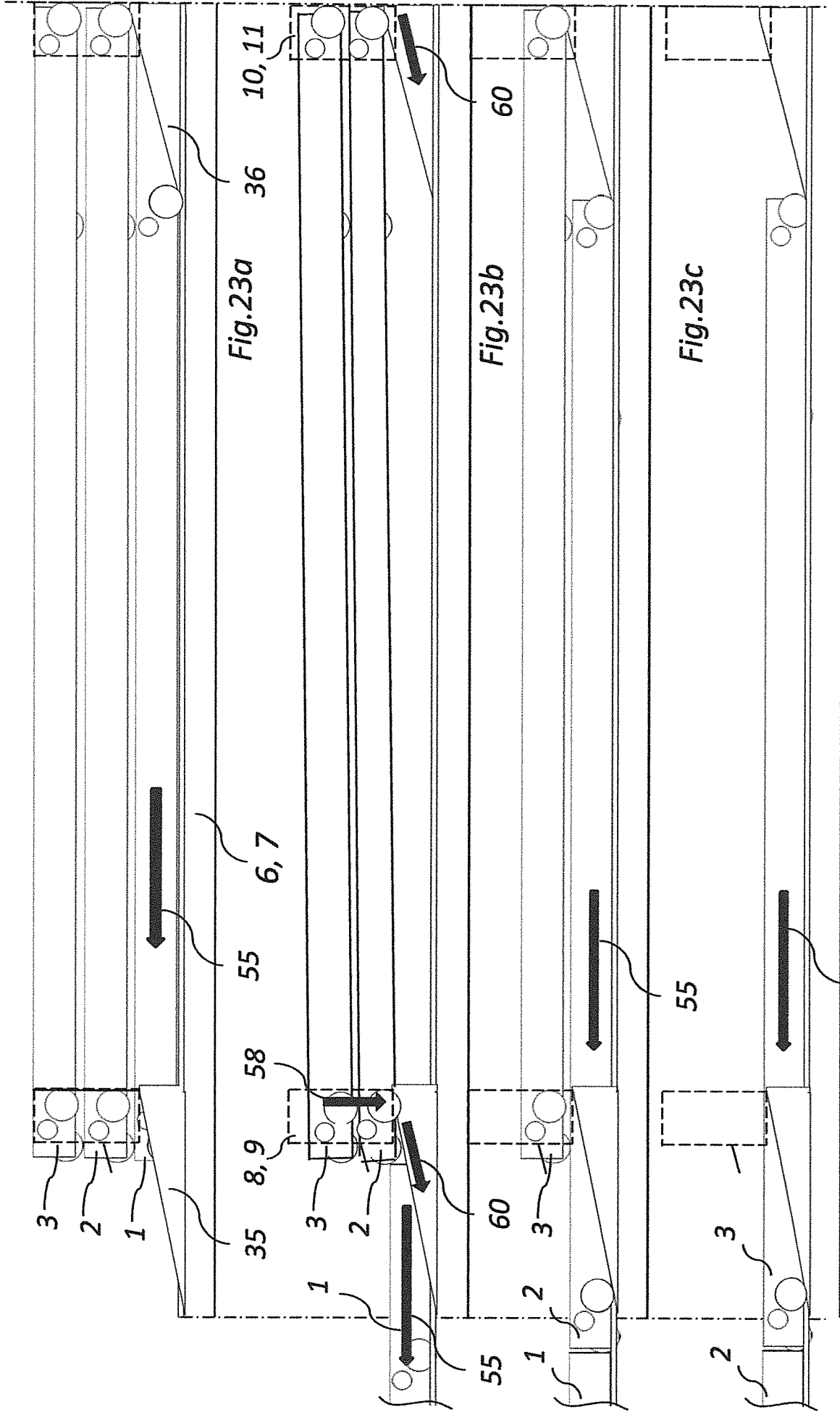

Fig. 23a

Fig. 23b

Fig. 23c

Fig. 23d

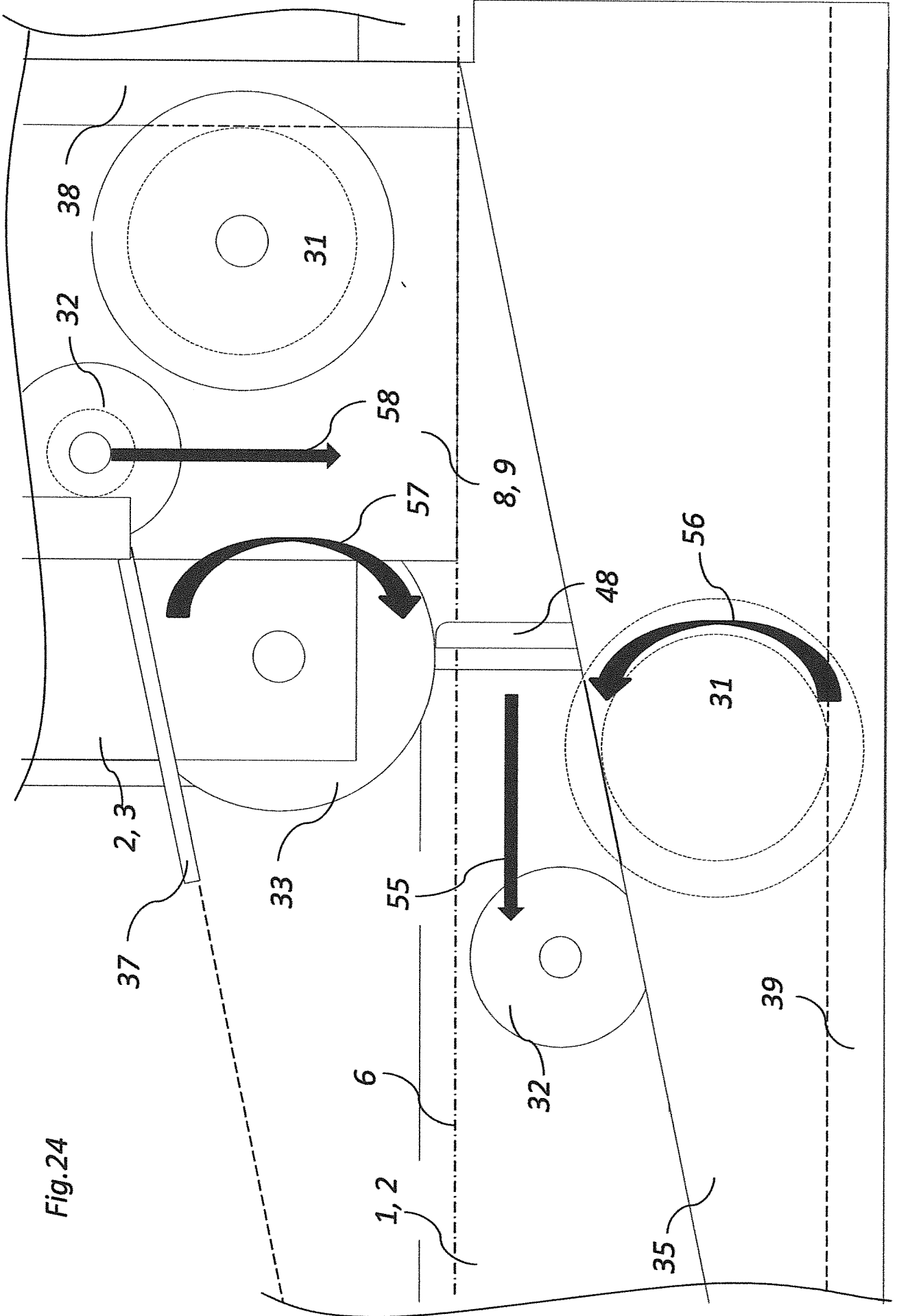

Fig. 24

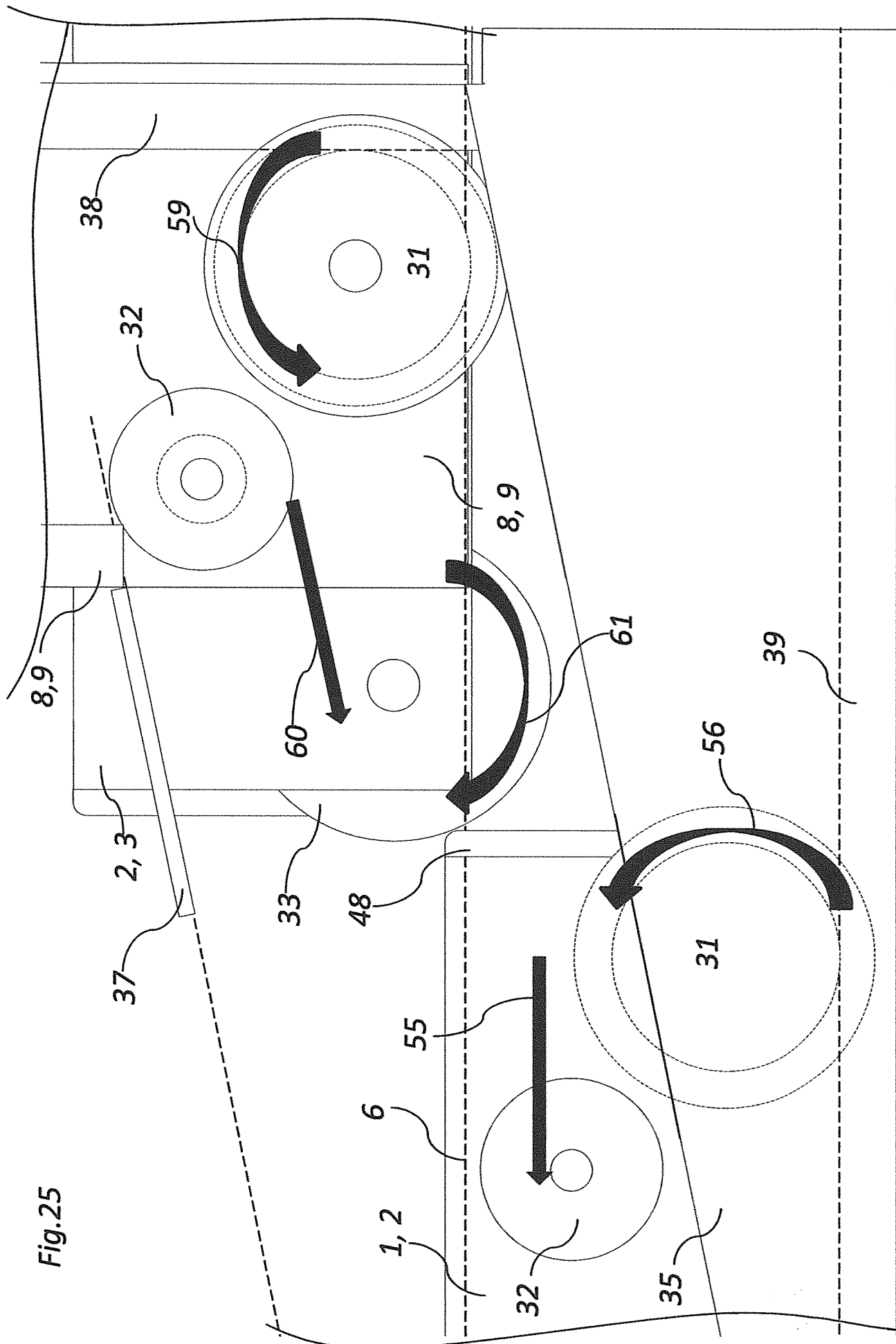

Fig.25

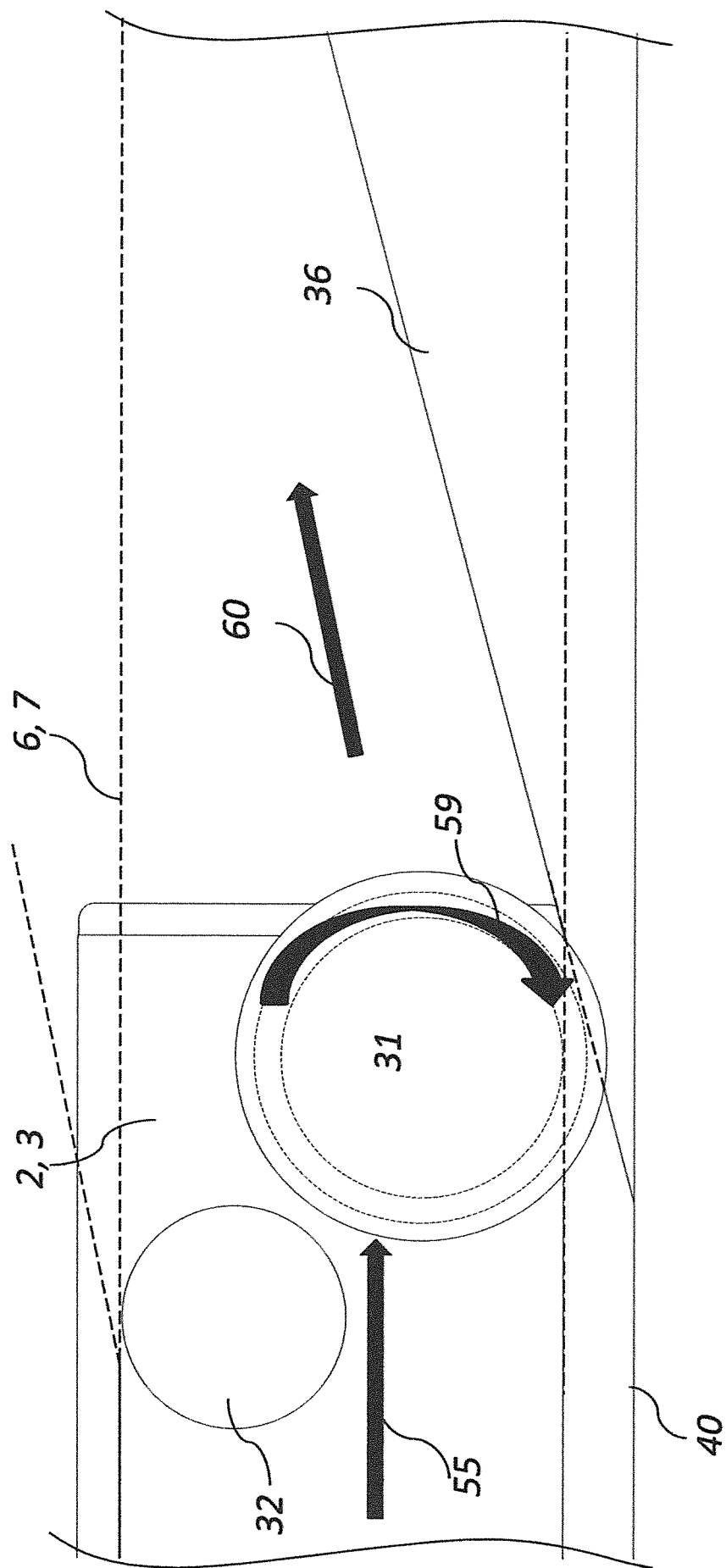

Fig.26

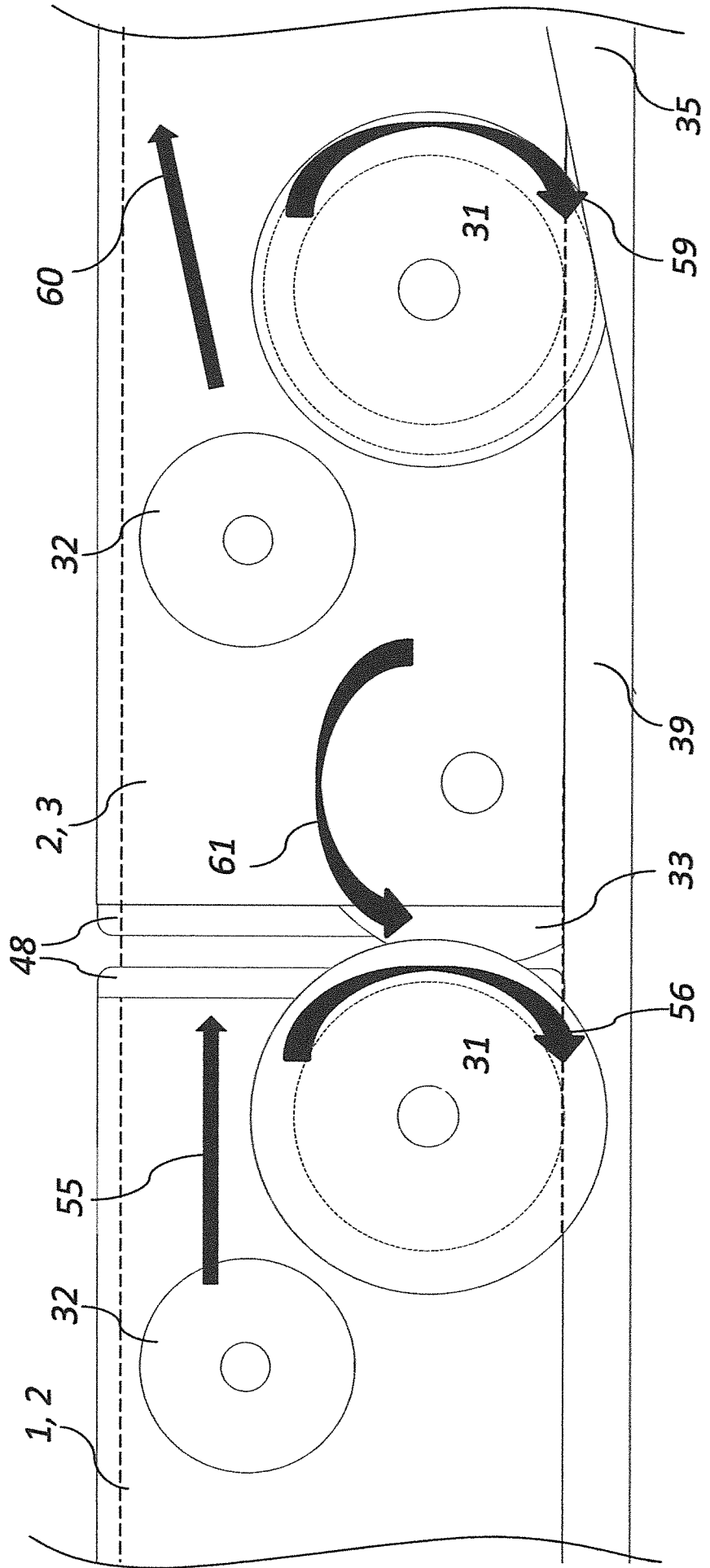

Fig.27

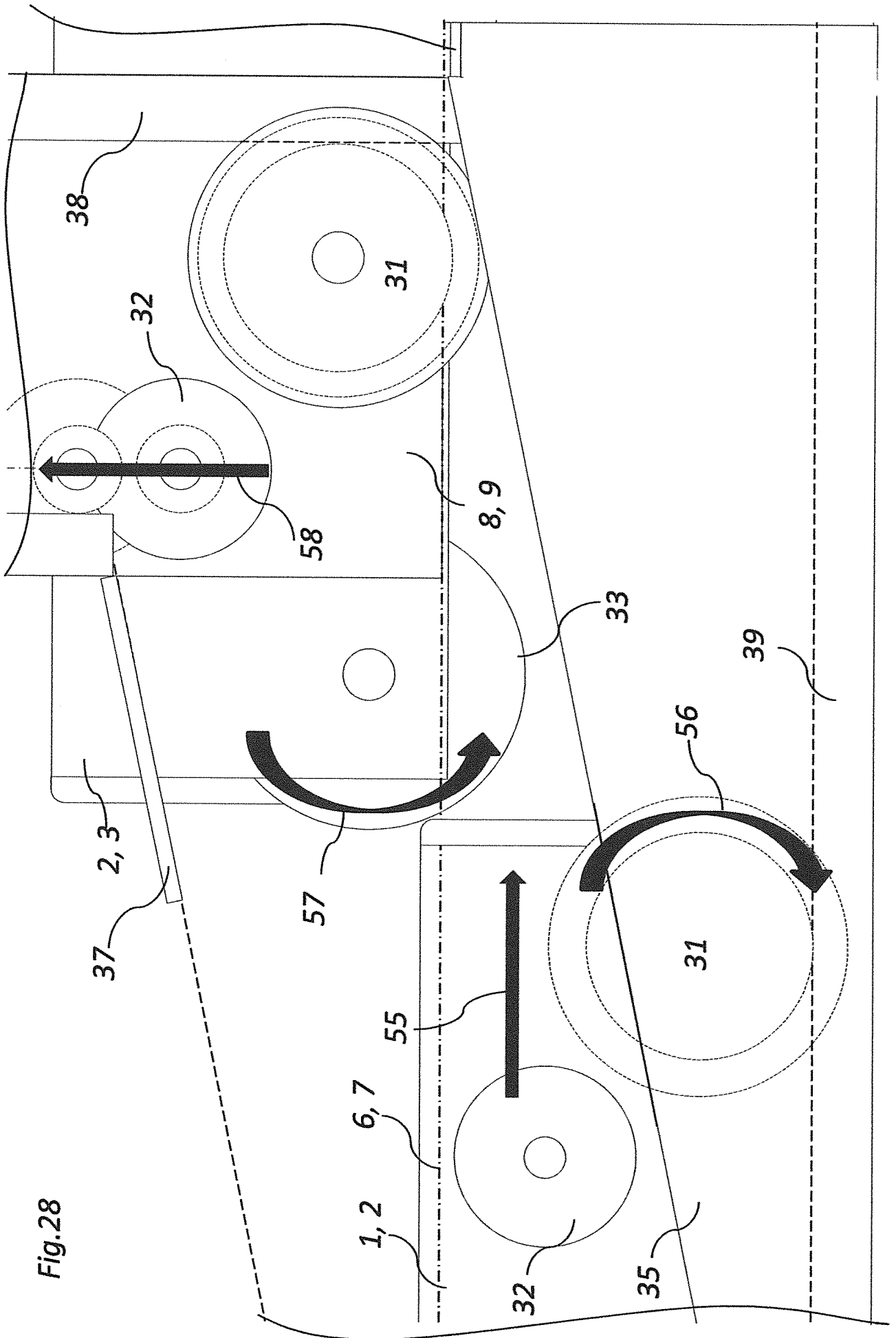

Fig.28