

April 21, 1931.

E. R. SWANSON

1,801,378

WINDING MACHINE

Filed May 8, 1928

3 Sheets-Sheet 1

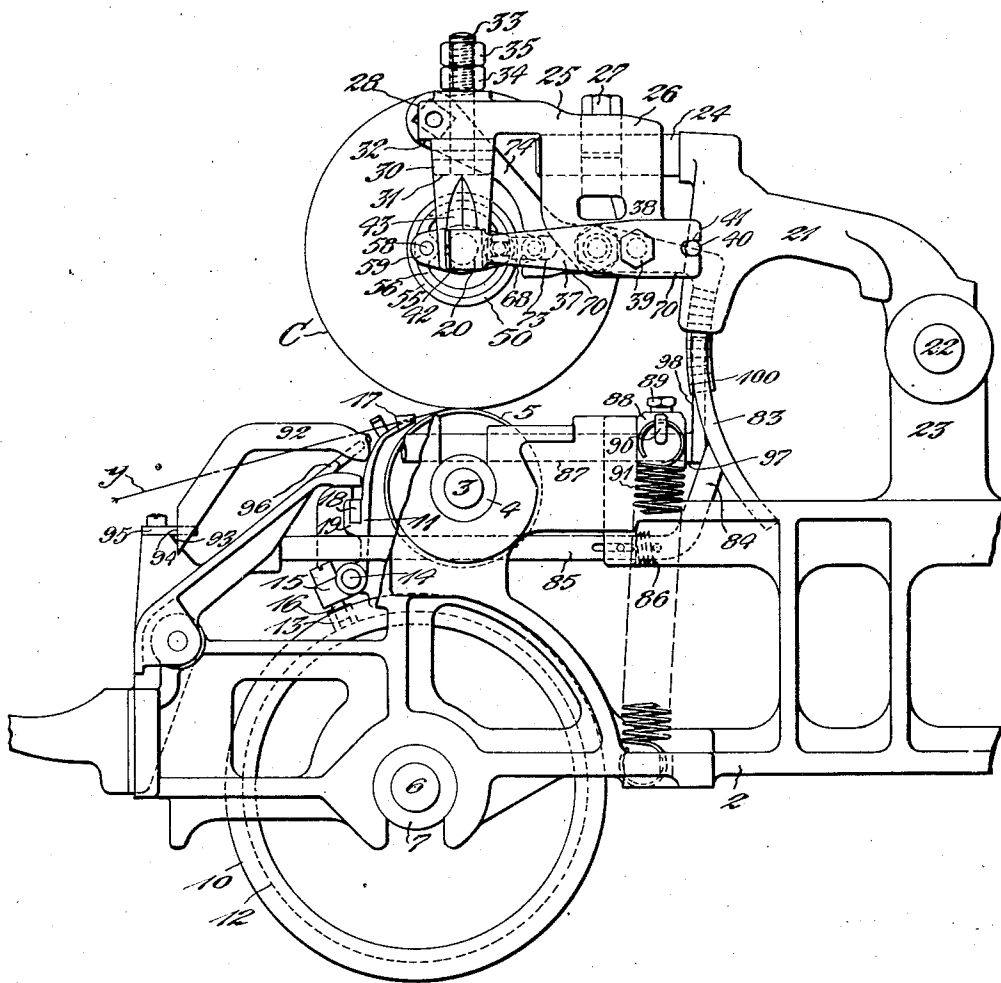

Fig. 1.

Inventor:

By Ernest R. Swanson

Watson, Brit. Morse & Seindell
Attorneys.

April 21, 1931.

E. R. SWANSON

1,801,378

WINDING MACHINE

Filed May 8, 1928

3 Sheets-Sheet 2

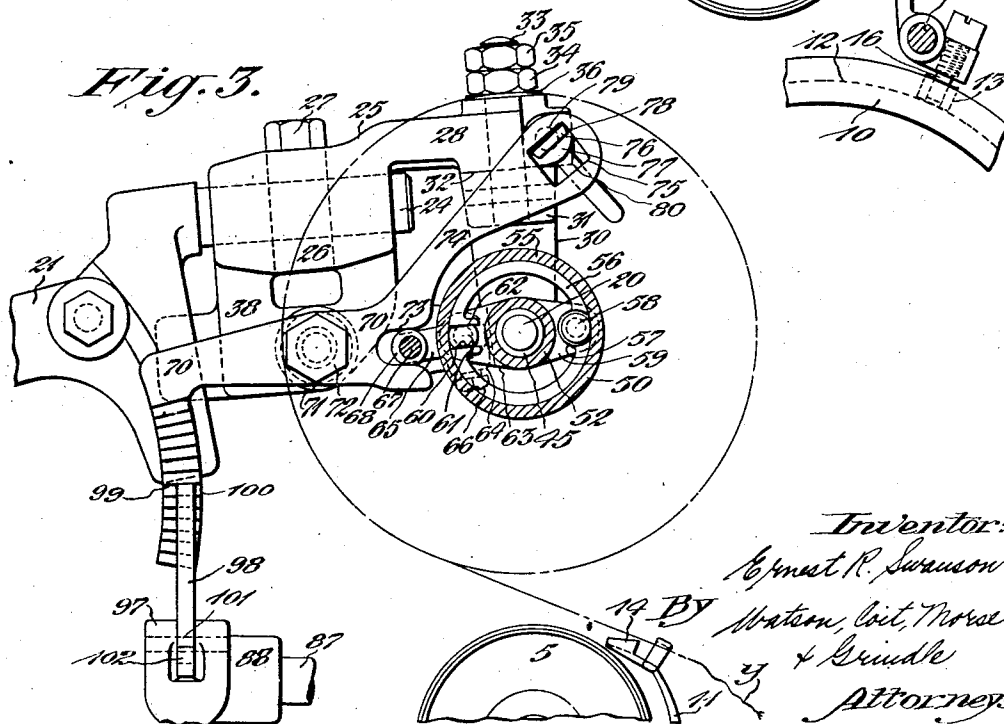
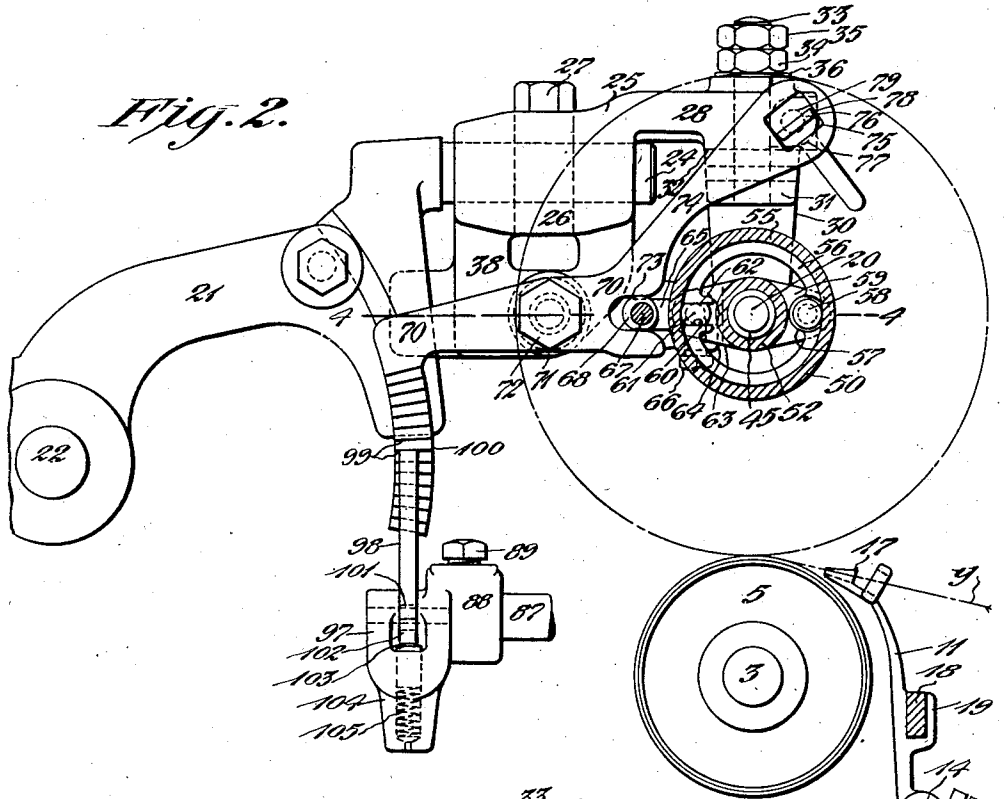

Inventor:
E. R. Swanson
BY *Watson, Coit, Morse & Brindle*
Attorneys

April 21, 1931.

E. R. SWANSON

1,801,378

WINDING MACHINE

Filed May, 8, 1928

3 Sheets-Sheet 3

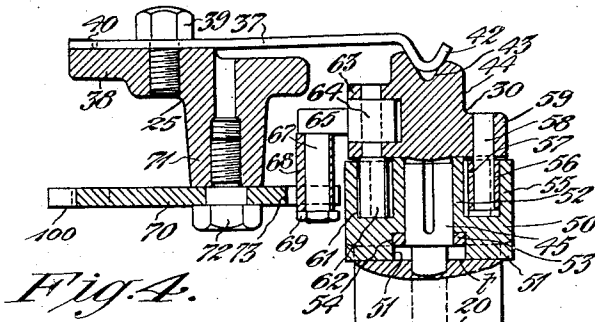

Fig. 4.

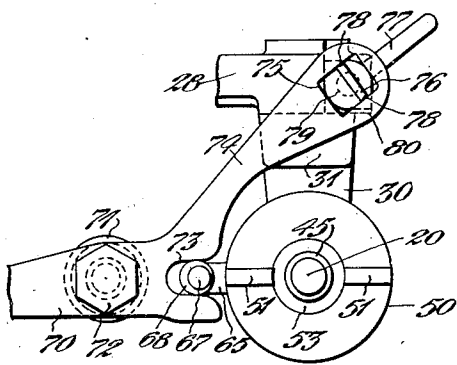

Fig. 5.

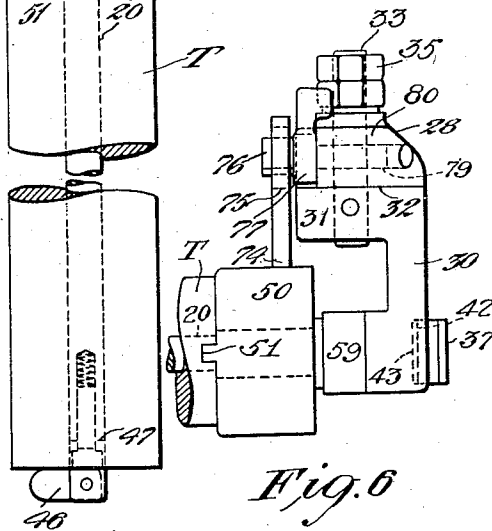

Fig. 6.

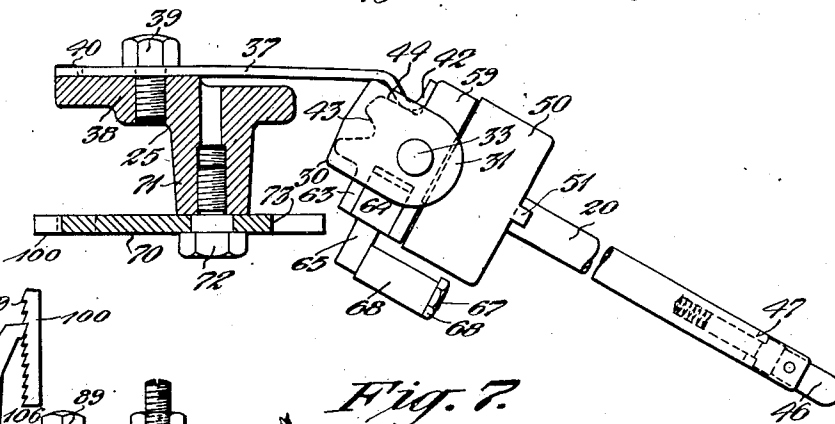

Fig. 7.

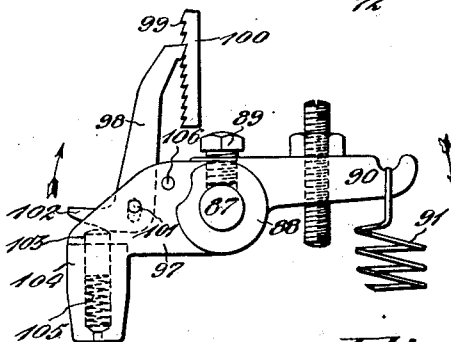

Fig. 8.

Inventor:
By Ernest R. Swanson
Watson, Coit, Morse & Crink
Attorneys.

UNITED STATES PATENT OFFICE

ERNEST R. SWANSON, OF CRANSTON, RHODE ISLAND, ASSIGNOR TO UNIVERSAL WINDING COMPANY, OF BOSTON, MASSACHUSETTS, A CORPORATION OF MASSACHUSETTS

WINDING MACHINE

Application filed May 8, 1928. Serial No. 276,164.

This invention relates to improvements in winding machines and particularly to machines of that type known as friction-driven or drum winders in which the cop or package is rotated through contact with a continuously driven drive-roll or drum. The present improvement relates to braking means for checking the rotation of the cop or package when the latter is removed from contact with the drive-roll or drum to arrest the winding operation.

A principal object of the invention is to provide means for promptly arresting the rotation of the cop or package to prevent it from turning under momentum after it is withdrawn from driving contact with the roll or drum.

Another object of the invention is to provide braking means operated automatically from the stopping-mechanism of the machine which acts to remove the cop from contact with the drive-roll or drum.

Another object of the invention is to provide braking means for the cop or package which may be conveniently released by the operator after the winding operation has been arrested so that the package may be turned or rotated manually to find a broken end or for other purposes.

Another object of the invention is to provide braking means which is automatically released when the winding-spindle is thrown out of operative position to doff a full cop or package and place an empty tube or carrier thereon.

Another object of the invention is to provide automatically operated braking means of the type specified which is simple in construction, economical to manufacture and durable over long periods of use.

Further objects of the improvement are set forth in the following specifications which describes a preferred form of construction of the invention, by way of example only, as illustrated by the accompanying drawings. In the drawings:

Fig. 1 is an end view of a conventional type of winding machine illustrating the present improved braking means as applied to use therewith;

Fig. 2 is an enlarged end view of the friction drive-roll or driving-drum of the machine, showing the means for supporting the cop or package in contact therewith and illustrating the brake-drum in section with the braking means in normal position during the winding operation;

Fig. 3 is a similar view showing the cop or package removed from contact with the drive-roll or drum and illustrating the brake-drum in section with the brake applied;

Fig. 4 is a plan view showing the mounting for the winding-spindle and illustrating the braking means in section on the line 4-4 of Fig. 2;

Fig. 5 is a detailed view showing the means for manually releasing the brake;

Fig. 6 is a side view of a portion of the brake-releasing means;

Fig. 7 is a view similar to Fig. 4 showing the winding-spindle thrown out of operative position with the brake released; and

Fig. 8 is a detailed view of the pawl and ratchet mechanism for raising the cop or package away from the drive-roll.

Referring first to Fig. 1 of the drawings, the winding machine herein illustrated is similar in general to that shown and described in United States Letters Patent No. 1,656,088 granted January 10, 1928. Winding machines of the present type are usually constructed in gang form with a plurality of winding units arranged in series along a common frame or bed. As all of the units are of the same construction and arrangement, however, only one winding mechanism is herein shown and described. In Fig. 1, 2 designates one of the cross-frames or supports for the various elements of the winding mechanism and 3 is the horizontal drive-roll shaft which is journaled in suitable bearings 4 on the cross-frames. The shaft 3 is continuously driven and carries a series of drive-rolls or drums 5 for rotating the cops or packages C as they are wound. A continuously rotated cam-shaft 6 extends parallel with and below the drive-roll shaft 3, being journaled in suitable bearings 7, also supported from the frame members 2.

The cam-shaft 6 carries one or a series of cylindrical cams 10 for reciprocating the traversing thread-guides 11 which deposit the turns of winding in place on the cops or packages. As herein shown a separate cam is provided for each winding unit, the cam 10 being of the usual form with a helical groove 12 on its periphery engaging a bowl or roller 13 which connects it to reciprocate the thread-guide 11. The thread-guide 11 is mounted to slide on a horizontally extending rod 14 and is provided with a lug 15 through which extends a screw or stud 16 forming the bearing for the bowl or roller 13. The thread-guide 11 reaches upwardly from the rod 14 and is provided with a head 17 formed with a thread-groove or slot through which the strand γ of yarn, thread or other material feeds to direct it to the winding. A horizontal bar 18 arranged above the rod 14 is engaged by a forked bearing 19 on the back of the thread-guide 11 to support the latter in position with its head 17 in close relation to the point of contact of the package on the drive-roll 5.

The cop or package C is wound on a suitable container or carrier which may consist of a paper tube or a wooden core T shown in detail in Fig. 4 as rotatably supported on the winding-spindle 20. The winding-spindle 20 is carried at the outer end of a swinging arm 21 which is pivoted to rock on a horizontal rod 22 supported from bearings 23 on the cross-frames 2. As herein illustrated the arm 21 terminates in a horizontal rod or stud 24 on which is held the support or mounting 25 for the winding-spindle 20. Referring to Figs. 2 and 3 of the drawings, the mounting 25 is constituted by a hub 26 clamped to the rod 24 by a bolt 27 and provided with a forwardly extending arm 28 to which is swiveled the spindle-support 30. The spindle-support 30 comprises a hub 31 abutting the under side of a boss 32 on the arm 28 and having a bolt or stud 33 extending through a central hole in the boss. A nut 34 and check-nut 35 are screwed on to the end of the bolt 33 abutting a washer 36 to hold the support 30 in place while adapting it to turn or swivel with respect to its mounting 25.

The winding-spindle 20 projects forwardly from the support 30, being made integral therewith or suitably attached thereto at its rearward end, see Fig. 4. The spindle 20 is normally held in parallel relation with the axis of the drive-roll 5 by means of a detent-latch 37 which permits it to be swung laterally by turning the support 30 on its swiveled bearing in the arm 28. The detent-latch 37 consists of a flat leaf spring fastened to the back of an arm 38 depending from the hub 26, see Fig. 1. The latch 37 is fastened to the arm 38 by a bolt 39 and held from turning thereon by a dowel pin 40 engaging

a slot 41 in its end. The free end of the latch 37 is bent around to form a detent projection or catch 42 adapted to spring into a V-shaped notch 43 on the rearward side of the spindle-support 30, see Fig. 4. When the spindle 20 is swung outwardly as shown in Fig. 7, to facilitate the doffing of the completed cop or package and the placing of a new tube thereon, the detent-catch 42 is sprung out of the notch 43 and rides over onto the flat face 44 of the support 30 to hold the spindle in this position.

The butt end of the spindle 20 is formed with an enlarged bearing 45 on which is rotatably mounted a flanged wheel 50 constituting the brake-drum for controlling the rotation of the cop-tube or carrier T. The cop-tube T, herein illustrated in the form of a wooden or fiber cylinder, is bored axially to adapt it to be slid onto the spindle 20 to support it rotatively therefrom. A usual form of spring-operated latch 46 is swiveled in a slot 47 on the outer end of the spindle 20 to adapt it to be turned into the position shown in Fig. 4 to retain the tube in place; and to release the tube the latch is turned into the position illustrated in Fig. 7. The wheel or brake-drum 50 is provided on its forward face with one or more radial splines 51 adapted to engage a suitable cross-slot t in the end of the tube T to connect the latter rotatively therewith. The brake-drum 50 has a hub 52 rotatable on the enlarged portion 45 of the spindle 20 with its end abutting the side of the support 30, the drum being held in place by means of a washer 53 forced onto the spindle and received in a recess 54 at the front of the brake-drum.

The brake-drum 50 has a cylindrical flanged rim 55, the interior of which is adapted to be engaged by a friction brake-band 56 shown in detail in Figs. 2, 3 and 4. The brake-band 56 is of the split type and has a supporting hub or bearing 57 held on a headed pin 58 driven into the side of a lug 59 on the support 30. Opposite its bearing 57 the brake-band 56 is formed with a parallel-sided opening 60 to adapt it to be expanded. Projecting into the opening 60 is a pin 61 having a flat-sided end portion 62 which serves as a cam for springing the ends of the band apart to cause it to be expanded to frictionally engage the interior of the flange 55. The pin 61 is journalled in a yoke-shaped bearing 63 on the side of the support 30, see Fig. 4, and carries a crank-arm 65 by means of which it is turned to cause its flattened cam portion 62 to expand the brake-band 56. The brake-arm 65 has a hub 64 received between the sides of the bearing 63 and fixedly secured on the pin 61 by a set-screw 66, see Fig. 2. Projecting forwardly from the brake-arm 65 is a crank-pin or stud 67 carrying an eccentric sleeve or bushing 68. The bushing 68 is clamped in place against the side of the

arm 65 by means of a nut 69 on the stud 67 and by releasing the nut the bushing may be adjusted rotatively for a purpose as later explained.

The brake-arm 65 is operated to actuate the braking means through the medium of a lever 70 controlled from the stopping-mechanism of the winding machine. The lever 70 is pivoted to a hub 71 projecting from the side of the arm 38 through the means of a stud 72 screwed into the hub, see Fig. 4. At one side of its pivot the lever 70 is forked to provide a slot or opening 73 which engages with the eccentric bushing 68 on the brake-arm 65. From its forked portion the lever 70 extends upwardly above the brake-drum 50 in an arm 74 which is provided at its end with a rectangular opening 75. Referring particularly to Figs. 5 and 6, a flat cam-plate or blade 76 projects from the side of a finger-lever 77 through the opening 75 and is formed with beveled edges 78 adapted to frictionally engage the sides thereof. The bevels 78 on the sides of the cam-plate 76 provide sharp edges to secure this frictional engagement while permitting the plate to be turned in the slot 75. The finger-lever 77 is carried at the end of a pin or stud 79 journaled in a bearing 80 at the end of the arm 28. It will be observed by reference to Fig. 3 that when the lever 70 is rocked to carry its forked portion downwardly the cam 62 will be turned to expand the brake-band 56 to effect the braking action. The finger-lever 77 is provided for the purpose of releasing the brake after the rotation of the cop has been once arrested, it being here noted that when the lever 77 is rocked upwardly into the position shown in Fig. 5 the edges of the cam-plate 76, which latter is disposed eccentric to the pivot of the lever, will act on the sides of the opening 75 to rock the arm 74 upwardly. This causes the forked portion of the lever 70 to be raised to lift the brake-arm 65 and thereby turn the cam 62 into neutral position as shown in Fig. 5.

The brake-actuating lever 70 is operated automatically to effect the braking action through pawl and ratchet mechanism illustrated in Figs. 1, 2, 3 and 8. These devices form a part of the stopping-mechanism of the winding machine and will be next described. It will be understood that the start of the winding operation the periphery of the cop-tube or carrier T rests upon the surface of the drive-roll 5, and as the yarn or other strand material is wound onto the tube the growth of the cop being built will cause the tube to be moved upwardly away from the drive-roll. Thus, as the cop-tube T rotates on the winding-spindle 20 the growing mass of yarn causes the spindle to recede from the drive-roll with its supporting arm 21 swinging upwardly about its axis on the rod 22. Dogging-means are usu-

ally provided to prevent the winding-spindle from moving toward the drive-roll after it has once been lifted by the growth in the winding so as to check any tendency of the package to vibrate or jump up and down. A preferred form of dogging-mechanism is shown in Fig. 1 as comprising an arcuate quadrant 83 fixedly attached to and depending from the cop-supporting arm 21. The quadrant 83 is disposed substantially concentric with the pivot 22 on which the arm 21 swings and its convex face is engaged by the beveled end of a friction dog 84. The dog 84 is formed as an arm projecting angularly from a sliding rod 85 which is supported in suitable bearings on the cross-frame 2 of the machine. The rod 85 is under the control of a coil spring 86 which tends to slide it longitudinally to maintain the dog 84 frictionally engaged with the quadrant 83 whereby to resist the downward movement of the arm 21. The dog 84 is manually released from the quadrant 83 to permit the return of the cop into driving contact with the drive-roll to start the winding operation after it has been arrested, but the means for effecting this action have no relation to the present invention and are therefore not herein described.

The main element for actuating the lifting means to remove the cop from driving contact with the drive-roll consists in a rockable rod 87, shown in Fig. 1 as being mounted in bearings on the cross-frame 2. Referring further to Figs. 2, 3 and 8, the rod 87 carries a lever 88 on its rearward end secured fast thereto by a set-screw 89 or by other suitable means. The lever 88 has a horizontal arm 90 to which is connected a coil spring 91 anchored at its lower end to the frame-member 2 as shown in Fig. 1. The spring 91 tends to rock the lever 88 in the direction indicated by the arrows in Fig. 8, but during the normal operation of the machine such rocking action is prevented by detent-means engaging the forward end of the rod 87. For this purpose the rod 87 is extended in a crooked crank-arm 92, see Fig. 1, having its end portion provided with a sharp blade 93 which engages a shoulder 94 on a detent-plate 95 carried by a rockable member 96. The member 96 forms an element of the stopping-mechanism of the machine and is rocked to release the detent-shoulder 94 from the blade 93 on the end of the rod 87 through suitable instrumentalities, not herein shown and described in detail as they may be of usual construction as illustrated in the prior patent hereinbefore referred to.

Referring now to Figs. 2, 3 and 8, the lever 88 has an arm 97 extending in opposite relation to its arm 90 and carrying an upright pawl 98. The upper sharpened end of the pawl 98 is adapted to engage with a series of ratchet teeth 99 formed on the side of a curved

extension 100 depending from the rearward arm of the brake-actuating lever 70. The pawl 98 is pivoted on the arm 97 of the lever 88 through a pin-and-slot connection indicated at 101 in Fig. 8. Projecting radially from the pivoted end of the pawl 98 is a toe 102 which is engaged by a plunger 103 slidable in a bearing 104 on the arm 97 and urged upwardly by a pocketed spring 105. The spring 105 acts through the plunger 103 to maintain the pawl 98 in engagement with the ratchet on the arm 100 and the pin-and-slot connection at 101 permits the pawl to follow the teeth as the ratchet extension 100 moves upwardly with the arm 21 carrying the winding-spindle whereby to guard against the pawl resting on the points of the teeth. The arm 97 of the lever 88 carries a pin 106 adapted to engage the side of the pawl 98 to release its end from the ratchet 100 when the lever 88 is rocked in the direction opposite to that indicated by the arrows in Fig. 8. It will be understood that when the lever 88 is rocked under the action of the spring 91 the pawl 98 will be moved bodily upward to lift the ratchet extension 100, this action first rocking the brake-lever 70 to operate the braking means; and the continued movement of the pawl operating to swing the arm 21 bodily upward to raise the cop C off from the drive-roll 5. The operation of the complete machine is as next more fully explained.

To process the machine for winding the pawl 98 is released from the ratchet-member 100 by turning the rod 87 in the direction opposite to that indicated by the arrows in Fig. 8, the pin 106 on the lever 88 being thereby caused to engage the side of the pawl to effect its release. The rod 87 is operated in this manner through the means of a manually-controlled starting-lever not herein shown and described, but which may be of the general arrangement as illustrated in the prior patent hereinbefore referred to. The starting-lever also acts to slide the rod 85 to release the dog 84 from the quadrant 83 and when this double release is effected the arm 21 is allowed to swing downwardly to carry the cop-holder or tube T into contact with the drive-roll 5.

The strand *y* of yarn, thread or other material is led from its source of supply, not herein shown, through the slot or groove in the thread-guide 11 and its end attached to the tube T. As the machine starts to operate the starting-lever is released to permit the dog 84 to return into engagement with the quadrant 83 and meanwhile the rocking of the rod 87 has engaged its end 93 with the detent-shoulder 94 on the plate 95 to maintain the lever 88 in position with the pawl 98 engaging the toothed side of the ratchet 100. The contact of the tube T with the periphery of the drive-roll 5 causes the

tube to be rotated on the spindle 20 to wind on the yarn and the thread-guide 11, which is continuously reciprocated from the cam 10, traverses the strand *y* longitudinally of the tube. As the winding builds upon the tube T with winding-spindle 20 recedes from the drive-roll 5 with its supporting arm 21 swinging upwardly about its pivot 22. During this movement of the winding-spindle away from the drive-roll the dog 84 acts in the manner as before explained to check retrogressive movement of the arm 21 and the pawl 98 maintains a step-by-step engagement with the teeth 99 on the ratchet 100.

The winding machine is usually provided with automatically-operated instrumentalities, not herein shown, for arresting the winding operation when the yarn breaks or runs out and also upon the completion of the package to a predetermined size. These instrumentalities act to release the blade 93 on the rod 87 from the detent-element 95, whereby the spring 91 is energized to rock the lever 88 in the direction indicated by the arrows in Fig. 8. This rocking action of the lever 88 causes the pawl 98 to act on the ratchet 100 to raise the arm 21 bodily to lift the cop or package C away from the drive-roll 5. During this lifting action on the arm 21 the pawl 98 forces the ratchet 100 upwardly to rock the brake-lever 70 on its pivot 72. As the lever 70 is rocked upwardly in this manner its forked portion is carried downwardly to depress the outer end of the brake-arm 65. That is to say, the slot 73 in the lever 70 acts on the eccentric bushing 68 to press the brake-arm 65 downwardly as shown in Fig. 3 and the cam portion 62 of the pin 61 is thereby turned in the opening 60 between the opposite ends of the brake-band 56. The brake-band 56 is thus expanded to cause it to frictionally grip the interior of the flange 55 on the brake-drum 50 which, as before explained, is rotatively connected with the cop-tube T. The brake is therefore applied simultaneously with the removal of the cop or package from contact with the drive-roll so that the rotation of the package is instantly arrested.

To insure this action of the braking-means instantaneously with the withdrawal of the package from the drive-roll the connection between the brake-lever 70 and brake-arm 65 may be adjusted with minute accuracy by turning the eccentric bushing 68 on the stud 67 in the manner as before explained.

After the cop or package has been raised away from the drive-roll and its rotation arrested the brake may be released to permit turning the cop on the winding-spindle 20 so as to find the broken end or for other purposes. This is especially desirable when "doubling" the yarns in the package, that is in winding several ends up. When a plurality of yarns are delivering to the package the breakage of any one will cause the stop-

ping of the winding, but it is difficult to find the broken end which adheres to the package unless the cop can be turned or rotated on the winding-spindle. The manual release of the brake for this purpose is readily accomplished by turning the finger-lever 77 upwardly as shown in Fig. 5 to cause its eccentric cam-plate 76 to raise the arm 74 of the lever 70. This shifts the brake-arm 65 into neutral position to turn the cam 62 to allow contraction of the brake-band 56.

After the brake has been released under operation of the lever 77 the cam-plate 76 continues to hold it released while the arm 70 is under pressure of the pawl 98 in maintaining the arm 21 in raised position. When, however, the pawl 98 is disengaged from the ratchet 100 to allow the package to drop back into contact with the drive-roll 5 the pressure on the lever 70 is relieved and the frictional grip of the cam-plate 76 on the sides of the opening 75 in the arm 74 of the lever 70 is released so that the finger-lever 77 drops back into first position, as shown in Figs. 2 and 3. Through this provision the lever 77 is automatically returned to inoperative position to release the brake-lever 70 for subsequent action after the package has been returned into driving contact with the roll 5 to again start the winding operation.

When the winding of the cop or package has been completed and the cop raised away from the drive-roll as shown in Fig. 3 of the drawings the operation of doffing the cop is facilitated by swinging the winding-spindle 20 forwardly toward the front of the machine. As the spindle 20 is swung out into this position as shown in Fig. 7 the detent-latch 37 is released in the manner as before explained and the brake-arm 65 is simultaneously disconnected from the brake-lever 70. In this way the brake is released so that after the full cop has been doffed a new cop-tube can be more conveniently placed on the spindle 20 and connected with the brake-drum 50. After the new tube has been applied to the spindle with the splines 51 on the brake-drum 50 engaging its cross-slot *t* the latch 46 is turned into position to hold it in place and the spindle is then swung back into operative relationship with the drive-roll. As the spindle is swung back to engage the detent-latch 37 with the notch 43 in the support 30 the bushing 68 on the stud 67 is carried into the slot 73 in the lever 70 to again connect the parts for automatic operation.

It will be observed from the foregoing that my improvement provides a particularly simple and efficient braking means for arresting the rotation of the cop or package as it is withdrawn from driving contact with the drive-roll or drum. The braking device is operated directly from the stopping-mechanism of the machine to arrest the ro-

tation of the cop or package simultaneously with its removal from driving contact.

As a further feature of improvement means are provided for manually releasing the brake when it is desired to rotate the cop to locate a broken end and this means is automatically returned to initial position when the winding is started again so that the braking means will be ready for operation at the next action of the stopping-mechanism.

While I have herein described and illustrated the improved device as embodied in a preferred form of construction it is to be understood that various modifications may be made in the structure and arrangement of its parts without departing from the spirit or scope of the invention.

Therefore, without limiting myself in this respect, I claim:

1. In a winding machine, the combination of a winding-spindle, a drive-roll for rotating the cop or package on the spindle, means for supporting the spindle to adapt it to move away from the drive-roll as the cop increases in diameter, means for raising the spindle-supporting means to remove the cop from driving contact with the drive-roll, braking means for arresting the rotation of the cop, and means acting between the raising-means and the spindle-support to actuate the braking means when the cop is removed from contact with the drive-roll.
2. In a winding machine, the combination of a winding-spindle, a drive-roll for rotating the cop or package on the spindle, a swinging arm for supporting the winding-spindle to adapt it to recede from the drive-roll during the growth in the winding, a brake-wheel adapted to be rotatively connected with the cop, a brake acting on said wheel to arrest the rotation of the cop, means for actuating the brake, and means adapted to operate on the brake-actuating means to apply the brake and simultaneously remove the cop from contact with the drive-roll.
3. In a winding machine, the combination of a drive-roll, means for rotatively supporting the cop or package in driving contact with the roll, a brake for arresting the rotation of the cop or package, means for actuating the brake, and means operating on the brake-actuating means to simultaneously apply the brake and remove the cop from driving contact with the drive-roll.
4. In a winding machine, the combination of a drive-roll, means for supporting the cop in driving contact with the roll and adapted to be displaced to remove the cop from driving contact, braking means for arresting the rotation of the cop, means for actuating the braking means, and automatically-operated means acting on the brake-actuating means to apply the brake and simultaneously displace the cop-supporting means to remove the cop from contact with the drive-roll.

5. In a winding machine, the combination of a drive-roll, a winding-spindle for rotatively supporting the cop in driving contact with the roll, a support for said winding-spindle adapted to be displaced to remove the cop from contact with the roll, braking means for arresting the rotation of the cop, a lever for actuating the braking means, and means operative upon the lever to apply the brake and acting through said lever to displace the spindle-support to remove the cop from contact with the drive-roll.
6. In a winding machine, the combination of a drive-roll, a winding-spindle, a support for the winding-spindle adapted to be displaced to remove the cop from contact with the drive-roll, braking means for arresting the rotation of the cop, a lever fulcrumed on the spindle-support and connected to operate the braking means, and means acting on the lever to apply the brake and simultaneously displace the spindle-support to remove the cop from contact with the drive-roll.
7. In a winding machine, the combination of a drive-roll, a winding-spindle for supporting the cop in contact with the drive-roll, a displaceable support for the winding-spindle, a brake-wheel rotatable with the cop, a brake acting on said wheel to arrest the rotation of the cop, a lever for operating the brake, and means for moving said lever to apply the brake and concurrently displace the spindle-support to remove the cop from contact with the drive-roll.
8. In a winding machine, the combination of a drive-roll, a winding-spindle for supporting the cop in contact with the drive-roll, a swinging arm for supporting the winding-spindle to adapt it to move away from the drive-roll, braking-means for arresting the rotation of the cop, means carried by the arm for actuating the braking means, and means for operating the brake-actuating means to apply the brake and concurrently swing the arm to remove the cop from contact with the drive-roll.
9. In a winding machine, the combination of a drive-roll, a winding-spindle, a swinging arm for supporting the winding-spindle to adapt it to move away from the drive-roll, braking means for arresting the rotation of the cop wound on the spindle, a lever for actuating the braking means, a ratchet connected to the brake-actuating lever, a pawl engaging the teeth on the ratchet, and means to operate the pawl to move the lever to apply the brake and concurrently swing the spindle-supporting arm to remove the cop from contact with the drive-roll.
10. In a winding machine, the combination of a drive-roll, a winding-spindle, means for supporting the spindle to maintain the cop in driving contact with the roll, braking means for arresting the rotation of the cop, a lever for actuating the braking means, ratchet-means connected with the lever, and means operating through the ratchet-means to actuate the lever to apply the brake and concurrently displace the spindle-support to remove the cop from contact with the drive-roll.
11. In a winding machine, the combination of a drive-roll, a winding-spindle, means for supporting the spindle to maintain the cop in driving contact with the roll, a brake-drum rotatable with the cop, a brake acting on said drum to arrest the rotation of the cop, a lever carried on the spindle-support and connected to actuate the brake, and means acting on said lever to apply the brake and to bodily displace the spindle-support to remove the cop from contact with the drive-roll.
12. In a winding machine, the combination of a drive-roll, a winding-spindle, braking means for arresting the rotation of the cop wound on the spindle, a lever for actuating the braking means, means for operating the lever to apply the brake, and ratchet-mechanism for maintaining a connection between the brake-lever and its operating-means as the winding-spindle recedes from the drive-roll during the growth in the winding.
13. In a winding machine, the combination of a drive-roll, a winding-spindle for supporting the cop in driving contact with the roll, braking means for arresting the rotation of the cop, means for actuating the braking means, a ratchet connected to the brake-actuating means, and means movable along the ratchet as the winding-spindle recedes from the drive-roll with the growth in the winding and adapted to operate thereon to operate the brake-actuating means to apply the brake.
14. In a winding machine, the combination of a drive-roll, a winding-spindle movable toward and away from the drive-roll, a support for the winding-spindle, a brake-drum rotatable with the cop, a brake acting on the drum to arrest the rotation of the cop, a crank-arm for actuating the brake, a lever pivoted on the spindle-support and connected to operate the crank-arm to apply the brake, a ratchet connected with said lever, a pawl engaging the ratchet and traveling thereon as the winding-spindle recedes from the drive-roll, and means for operating said pawl to actuate the lever to apply the brake.
15. In a winding machine, the combination of a drive-roll, a winding-spindle, a swinging arm for supporting the winding-spindle to move toward and away from the drive-roll, a brake-drum rotatable with the cop wound on the spindle, a brake engaging said drum to arrest the rotation of the cop, a brake-actuating lever pivoted on the arm and formed with a depending ratchet, a pawl

adapted to successively engage the teeth of the ratchet, and means to move the pawl to operate the brake-actuating lever and swing the arm to simultaneously apply the brake and remove the cop from contact with the drive-roll.

16. In a winding machine, the combination of a brake-wheel, a brake acting thereon, a crank-arm for operating the brake, a crank-pin on said arm, an eccentric bushing adjustable rotatively of said pin, and a brake-actuating lever engaging the eccentric bushing to operatively connect it with the crank-arm while providing for adjustment of the connection by turning the bushing on the pin.

17. In a winding machine, the combination of a winding-spindle, means to rotate the spindle, braking means for arresting the rotation of the cop wound on the spindle, automatically-operated means for actuating the braking means to apply the brake, and manually-operable means for releasing the brake without starting the rotation of the spindle whereby to permit the cop to be turned by hand to find a broken end in piecing up the yarn.

18. In a winding machine, the combination of a winding-spindle, a drive-roll for rotating the cop on the spindle, means for removing the cop from contact with the drive-roll, braking means for arresting the rotation of the cop upon its removal from the drive-roll, and manually-operable means for releasing the braking means while the cop is removed from the drive-roll to permit it to be turned to facilitate piecing up the yarn.

19. In a winding machine, the combination of a winding-spindle, a drive-roll, means for supporting the winding-spindle to maintain the cop in driving contact with the roll, braking means for arresting the rotation of the cop, means acting on the spindle-supporting means to remove the cop from contact with the drive-roll and to concurrently actuate the braking means, and manually-operable means for releasing the braking means after the cop has been removed from contact with the drive-roll to permit it to be turned to find the broken end in piecing up the yarn.

20. In a winding machine, the combination of a winding-spindle, braking means for arresting the rotation of the cop wound on the spindle, a lever for actuating the braking means, said lever formed with a rectangular slot, a pivoted finger-lever, and a cam-plate projecting through the slot in the brake-lever and adapted to be turned by the finger-lever to cause its edges to engage the sides of the slot to rock the brake-actuating lever to release the braking means.

21. In a winding machine, the combination of a brake-wheel, a brake for arresting the rotation of the brake-wheel, a lever for actuating the brake, said lever provided with an arm formed with a rectangular opening, a

pivoted finger-lever, a cam-plate arranged eccentrically of the pivot of the finger-lever and projecting through the opening in the brake-lever, said cam-plate formed with beveled edges adapted to engage the sides of the opening in the brake-lever to shift the latter to release the brake.

22. In a winding machine, the combination of a drive-roll, a winding-spindle normally maintained in alined relation with the roll to support the cop in driving contact therewith, means for mounting the winding-spindle to adapt it to be swung out of operative position to facilitate the doffing of the cop or package therefrom, braking means for arresting the rotation of the cop when it is removed from driving contact with the roll, and means for releasing the braking means when the winding-spindle is swung out of operative position.

23. In a winding machine, the combination of a drive-roll, a winding-spindle normally maintained in alined relation with the drive-roll to support the cop in driving contact therewith, a swiveled mounting for supporting the winding-spindle to adapt it to swing out of operative position, braking means on the spindle for arresting the rotation of the cop, means for actuating the braking means when the cop is removed from driving contact with the roll, and means for releasing the brake-actuating means when the winding-spindle is swung out of operative position.

In testimony whereof I hereunto affix my signature.

ERNEST R. SWANSON.