

J. SAX.
 SCULLING APPARATUS FOR BOATS.
 APPLICATION FILED OCT. 19, 1910.

1,003,516.

Patented Sept. 19, 1911.

3 SHEETS—SHEET 1.

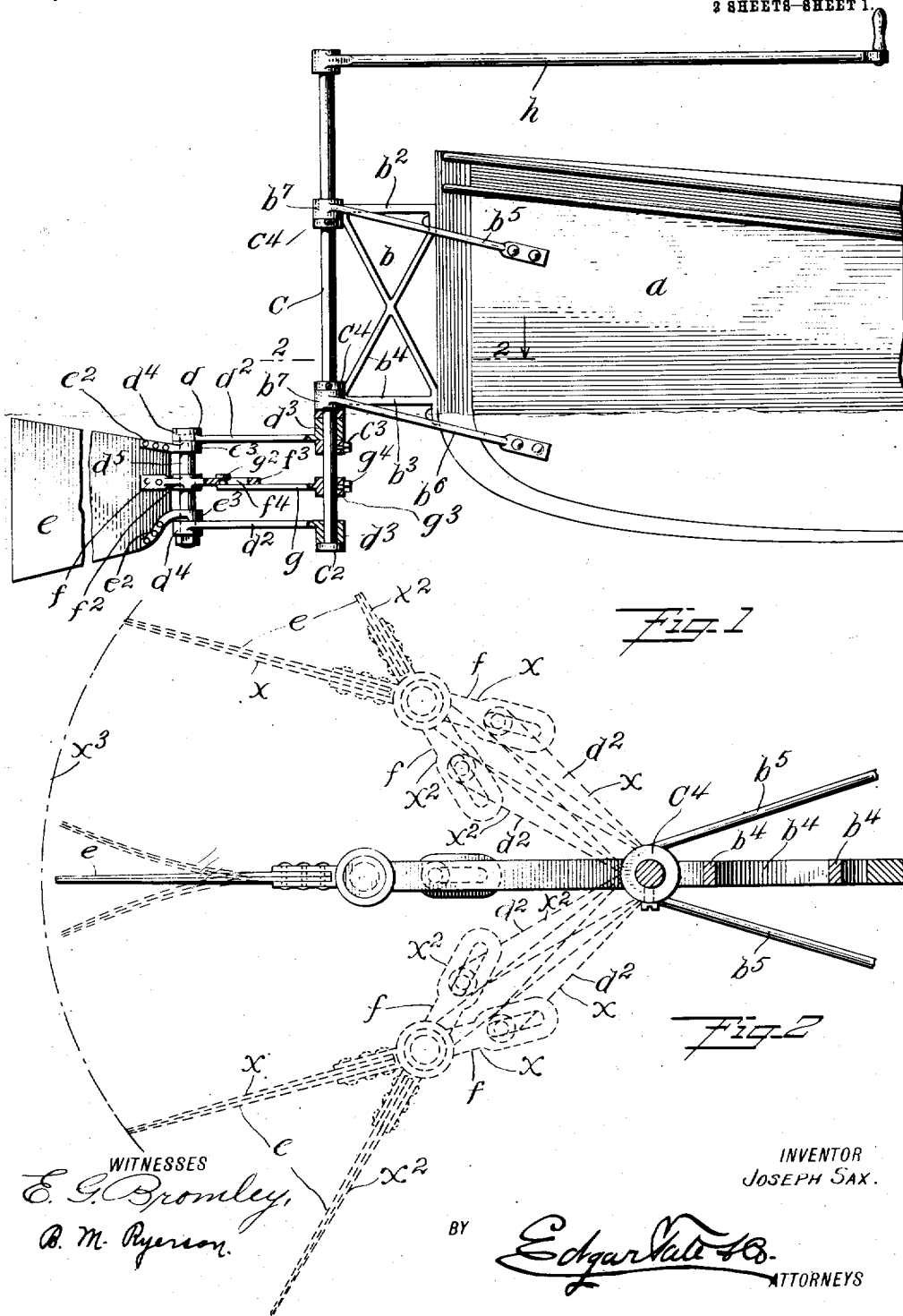

J. SAX.
SCULLING APPARATUS FOR BOATS.
APPLICATION FILED OCT. 19, 1910.

1,003,516.

Patented Sept. 19, 1911.

2 SHEETS—SHEET 2.

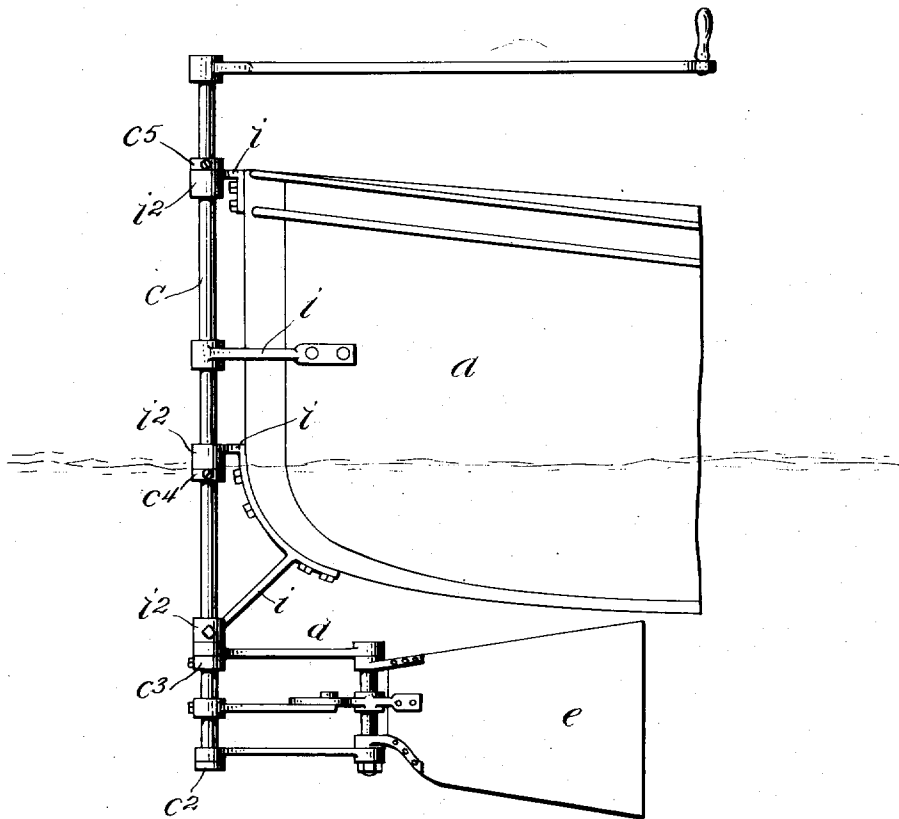

Fig. 3

WITNESSES
E. G. Bromley
B. M. Ayreson.

INVENTOR
JOSEPH SAX.

BY *Edgar Tate Co.*
ATTORNEYS

UNITED STATES PATENT OFFICE.

JOSEPH SAX, OF BROOKLYN, NEW YORK, ASSIGNOR OF ONE-HALF TO ANDERS P. PATERSEN, OF BROOKLYN, NEW YORK.

SCULLING APPARATUS FOR BOATS.

1,003,516.

Specification of Letters Patent. Patented Sept. 19, 1911.

Application filed October 19, 1910. Serial No. 587,853.

To all whom it may concern:

Be it known that I, JOSEPH SAX, a citizen of the United States, and residing at Brooklyn, in the county of Kings and State of New York, have invented certain new and useful Improvements in Sculling Apparatus for Boats, of which the following is a specification, such as will enable those skilled in the art to which it appertains to make and use the same.

This invention relates to means for sculling boats, and the object thereof is to provide an improved apparatus of this class which is simple in construction and operation and which may be applied to a boat in different positions, or in different ways either at the stern or bow thereof, or at the sides thereof if desired, and by means of which a boat may be easily propelled or drawn through the water and at the same time steered or guided; and with this and other objects in view the invention consists in a device or apparatus of the class specified, constructed as hereinafter described and claimed.

The invention is fully disclosed in the following specification, of which the accompanying drawing forms a part, in which the separate parts of my improvement are designated by suitable reference characters in each of the views, and in which;—

Figure 1 is a side view of the stern portion of a boat provided with my improved sculling device or apparatus, part of the construction being in section; Fig. 2 a sectional plan view thereof and indicating in dotted lines the method of the operation, and;—Fig. 3 a view similar to Fig. 2 but showing my improvement applied to the bow of a boat.

In the accompanying drawing I have shown at *a* in Fig. 1, the stern of the hull of a boat, and in the practice of my invention as shown in Figs. 1 and 2, I secure thereto an outrigger support *b* consisting, in the form of construction shown, of a central framework composed of top and bottom members *b*² and *b*³, and diagonally arranged brace members *b*⁴, and having top

side brace members *b*⁵ and bottom side brace members *b*⁶, but said outrigger support may be made in any desired manner.

The support *b* is provided with keepers *b*⁷ through which is passed a vertically arranged shaft *c*, on which is rotatably mounted a sculler blade support *d* consisting of top and bottom arms *d*² provided at their inner ends with heads *d*³ through which the shaft *c* passes, and at their outer ends with heads *d*⁴ through which is passed a vertically arranged shaft *d*⁵ on which is rotatably supported a sculler blade *e*.

The sculler blade support *d* is connected with the shaft *d*⁵, in the form of construction shown, by means of forked arms *e*², in which the blade *e* is secured, said arms being provided with heads *e*³ through which the shaft *d*⁵ passes, and secured to the sculler blade *e* between the arms *e*² is an arm *f* having a central bearing *f*² and an extension *f*³ having a longitudinal slot *f*⁴, and secured to the shaft *c* centrally of the arms *d*² is an arm *g* provided with a headed pin *g*² which passes through the slot *f*⁴ in the arm *f*. The arm *g* is provided with a head *g*³ through which the shaft *c* passes and is secured to said shaft by a set screw *g*⁴ in the construction shown, but may be secured to said shaft in any desired manner.

Connected with the upper end of the shaft *c*, in the form of construction shown, is an arm *h* which normally extends forwardly over the stern end of the boat and may be operated by hand to oscillate or rotate the shaft *c*, but the said shaft *c* may be provided with a wheel instead of the arm *h* and may be operated in any desired manner.

The combined length of the arms *f* and *g* is greater than the length of the arms *d*² and as the shaft *c* is oscillated or partially rotated the blade *e* and the support *d* thereof are thrown into the different positions shown in dotted lines in Fig. 2. At the limit of the outward or lateral movement of the blade *e* and the support *d*, the said parts together with the arm *f* are in the position shown at *x*, but at the beginning of the inward movement of said parts they are

thrown in the position shown at α^2 , this result being accomplished by the arms f and g and as the blade f and its support d are swung through the arm α^3 the boat is rapidly propelled as will be readily understood.

The blade e is preferably made of elastic material so that it will bend as indicated in dotted lines in Fig. 2, and said blade is also preferably composed of separate sheets of leather secured together but may be composed of other fibrous material, said material or materials in either event being treated so as to render them impervious to water, but the blade e may be composed of any preferred material.

In Fig. 3 I have shown an improved propelling device or apparatus applied to the bow of the boat and the shaft c is supported by means of brackets or arms i which are secured to the boat and provided with heads or keepers i^2 and through which said shaft passes, and in which said shaft is rotatable. In this use of my improvement the various parts of the sculling apparatus are constructed and operated exactly as in the construction shown in Figs. 1 and 2 except that the blade e and its support d extend backwardly from the shaft c , and the boat is pulled through the water instead of being propelled as when the sculling device is applied as shown in Figs. 1 and 2. In this form of construction the blade d and its support e are also mounted beneath the boat and this position and operation of the various parts of the sculling apparatus requires, as will be understood, deeper water than when the said sculling device or apparatus is mounted or employed as shown in Figs. 1 and 2, but the operative parts of the said sculling device or apparatus need not be mounted as low or as far back as shown in Fig. 3, it being understood that by projecting the supports i of the shaft c forwardly the operative parts e and d may be raised.

It will also be apparent that when my improved sculling device or apparatus is mounted as shown in Figs. 1 and 3, by turning the arm h to one side the operative parts including the blade e and its support d may be turned into either of the positions indicated in dotted lines at α in Fig. 2 and held in such position, and when said parts are in either of these positions the device or apparatus will serve for steering or guiding the boat or may be made to so serve by simply vibrating or oscillating the arm h to a limited extent so as to throw said parts into the position indicated both at α and α^2 , or the said parts may be held in the position shown at α^2 if desired by simply holding the arm h stationary in which event, as will be understood, the bow of the boat may be turned in either direction as may be desired.

The shaft c , in the form of construction shown, is provided at its lower end with a head c^2 , and said shaft is also provided with collars c^3 , c^4 and c^5 which are rigidly secured thereto, and the blade support d rests on the head c^2 , and said head together with the blade support d and the collars c^3 , c^4 and c^5 prevent the vertical movement of the shaft c , and these parts may be detached from the boat and again applied thereto whenever desired.

My invention is also not limited to the manipulation of the shaft c by hand and a power mechanism may be employed for this purpose if desired, and my improved sculling device may be applied to any kind or class of boats and can be operated by anyone after a little experience and without any previous knowledge or experience in the art of propelling or sculling boats.

The entire apparatus may also be carried in a motor boat and may be applied thereto at any time if the propelling mechanism of the boat should break down, and when applied either to the bow or stern of a boat room necessary to operate oars is reserved for other purposes, and the boat may be propelled through much narrower spaces than is possible when oars are used as a propelling means; but my improved sculling apparatus may, if desired, be applied to the sides of a boat as well as to the stern or bow thereof, and changes in and modifications of the construction herein described may be made, within the scope of the appended claims, without departing from the spirit of my invention, or sacrificing its advantages.

Having fully described my invention, what I claim as new and desire to secure by Letters Patent, is;—

1. A sculling apparatus for boats consisting of an outrigger support or supports adapted to be secured to a boat, a vertically arranged shaft rotatably mounted in said support or supports, a blade support rotatably mounted on said shaft, a blade rotatably mounted on said blade support, an arm rigidly secured to said blade and another arm rigidly secured to said shaft and loosely connected with the arm which is secured to said blade.

2. The combination with a boat, of a sculling device consisting of a vertically arranged rotatable shaft, a blade support rotatably mounted on said shaft, a blade rotatably mounted on said blade support, an arm secured to said blade and another arm secured to said shaft and loosely connected with the first named arm.

3. A sculling apparatus for boats consisting of outrigger supports adapted to be secured to a boat, a vertically arranged shaft

rotatably mounted in said supports, a blade support rotatably mounted on said shaft, a blade rotatably mounted on said blade support, and devices connected with said shaft
 5 and said blade for rotating said blade and blade support when said shaft is rotated.

In testimony that I claim the foregoing as

my invention I have signed my name in presence of the subscribing witnesses this 17th day of October, 1910.

JOSEPH SAX.

Witnesses:

C. E. MULREANY,

B. M. RYERSON.

Correction in Letters Patent No. 1,003,516.

It is hereby certified that in Letters Patent No. 1,003,516, granted September 19, 1911, upon the application of Joseph Sax, of Brooklyn, New York, for an improvement in "Sculling Apparatus for Boats," an error appears requiring correction as follows: In the grant and in the heading to the printed specification the name of the assignee was erroneously written and printed "Anders P. Patersen," whereas said name should have been written and printed *Anders P. Petersen*; and that the said Letters Patent should be read with this correction therein that the same may conform to the record of the case in the Patent Office.

Signed and sealed this 10th day of October, A. D., 1911.

[SEAL.]

E. B. MOORE,

Commissioner of Patents.

rotatably mounted in said supports, a blade support rotatably mounted on said shaft, a blade rotatably mounted on said blade support, and devices connected with said shaft
 5 and said blade for rotating said blade and blade support when said shaft is rotated.

In testimony that I claim the foregoing as

my invention I have signed my name in presence of the subscribing witnesses this 17th day of October, 1910.

JOSEPH SAX.

Witnesses:

C. E. MULREANY,

B. M. RYERSON.

Correction in Letters Patent No. 1,003,516.

It is hereby certified that in Letters Patent No. 1,003,516, granted September 19, 1911, upon the application of Joseph Sax, of Brooklyn, New York, for an improvement in "Sculling Apparatus for Boats," an error appears requiring correction as follows: In the grant and in the heading to the printed specification the name of the assignee was erroneously written and printed "Anders P. Patersen," whereas said name should have been written and printed *Anders P. Petersen*; and that the said Letters Patent should be read with this correction therein that the same may conform to the record of the case in the Patent Office.

Signed and sealed this 10th day of October, A. D., 1911.

[SEAL.]

E. B. MOORE,

Commissioner of Patents.

Correction in Letters Patent No. 1,003,516.

It is hereby certified that in Letters Patent No. 1,003,516, granted September 19, 1911, upon the application of Joseph Sax, of Brooklyn, New York, for an improvement in "Sculling Apparatus for Boats," an error appears requiring correction as follows: In the grant and in the heading to the printed specification the name of the assignee was erroneously written and printed "Anders P. Patersen," whereas said name should have been written and printed *Anders P. Petersen*; and that the said Letters Patent should be read with this correction therein that the same may conform to the record of the case in the Patent Office.

Signed and sealed this 10th day of October, A. D., 1911.

[SEAL.]

E. B. MOORE,
Commissioner of Patents.