

(12) **United States Patent**
Legus

(10) **Patent No.:** **US 10,034,436 B2**
(45) **Date of Patent:** **Jul. 31, 2018**

(54) **COLLAPSIBLE PLANT SUPPORT**
(71) Applicant: **Chad M. Legus**, Elkhart, IN (US)
(72) Inventor: **Chad M. Legus**, Elkhart, IN (US)

USPC 47/24.1, 29.6, 31, 31.1, 44-47, 70
See application file for complete search history.

(*) Notice: Subject to any disclaimer, the term of this patent is extended or adjusted under 35 U.S.C. 154(b) by 0 days.

(56) **References Cited**

U.S. PATENT DOCUMENTS

2,047,958 A * 7/1936 Frees A01G 13/0243
47/32.5
6,088,953 A * 7/2000 Morgan A01G 13/043
135/125
6,520,365 B2 * 2/2003 Schneider A45C 7/0077
220/666

(Continued)

FOREIGN PATENT DOCUMENTS

CA 2382932 A1 * 10/2003 A45C 7/0077
DE 2533065 B1 * 12/1976 A01G 9/12

(Continued)

Primary Examiner — David J Parsley
Assistant Examiner — Danielle A Clerkley
(74) *Attorney, Agent, or Firm* — Larry E. Henneman, Jr.;
Henneman & Associates, PLC

(57) **ABSTRACT**

A novel collapsible plant support includes a collapsible coil adapted to rest on a flat surface. In a particular embodiment, the collapsible plant support includes a plurality of vertical support structures coupled to the collapsible coil so as to provide additional support. In another particular embodiment, a collapsible plant support includes plant receptacle receiving element that supports both a collapsible coil and also a plant receptacle. In a more particular embodiment, the plant receptacle receiving element includes fluid ducts for connecting multiple plant receptacle receiving elements into a fluid network. In another embodiment, the coil is disposed within a helical sleeve coupled to a flexible, cylindrical mesh.

18 Claims, 27 Drawing Sheets

(21) Appl. No.: **15/660,726**
(22) Filed: **Jul. 26, 2017**

(65) **Prior Publication Data**
US 2017/0318760 A1 Nov. 9, 2017

Related U.S. Application Data

(63) Continuation-in-part of application No. 14/251,038, filed on Apr. 11, 2014, now Pat. No. 9,717,188.

(51) **Int. Cl.**
A01G 9/12 (2006.01)
A01G 17/06 (2006.01)
A01G 17/04 (2006.01)
A01G 13/02 (2006.01)
B29C 45/14 (2006.01)
A01G 17/00 (2006.01)
A01G 9/00 (2018.01)
B29L 31/06 (2006.01)
B29L 31/00 (2006.01)

(52) **U.S. Cl.**
CPC *A01G 17/06* (2013.01); *A01G 9/12* (2013.01); *A01G 13/0243* (2013.01); *A01G 17/04* (2013.01); *B29C 45/14* (2013.01); *A01G 9/00* (2013.01); *A01G 17/00* (2013.01); *B29L 2031/06* (2013.01); *B29L 2031/7004* (2013.01)

(58) **Field of Classification Search**
CPC A01G 9/12; A01G 9/126; A01G 17/04; A01G 17/06; A01G 13/0237; A01G 13/0234; A45C 7/077

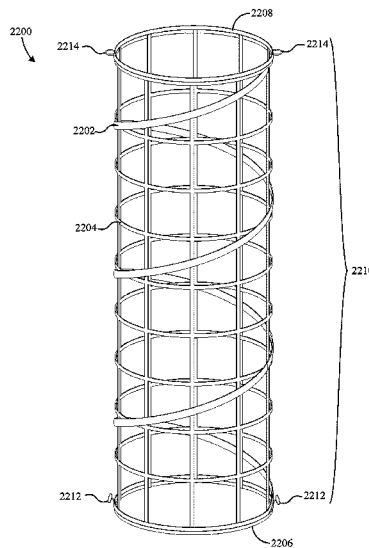

(56)

References Cited

U.S. PATENT DOCUMENTS

6,830,170 B2 * 12/2004 Abel A01M 31/006
190/107
2009/0044446 A1 * 2/2009 Kellogg A01G 9/12
47/45

FOREIGN PATENT DOCUMENTS

DE 2533065 B1 * 12/1976 A01G 9/12
FR 2876245 A1 * 4/2006 A01G 13/043
FR 2876245 A1 * 4/2006 A01G 13/043
GB 2383260 A * 6/2003 A45C 7/0063
WO WO-03008283 A1 * 1/2003 A45C 7/0077
WO WO 2009051500 A1 * 4/2009 A01G 13/0212
WO WO-2009051500 A1 * 4/2009 A01G 13/0212

* cited by examiner

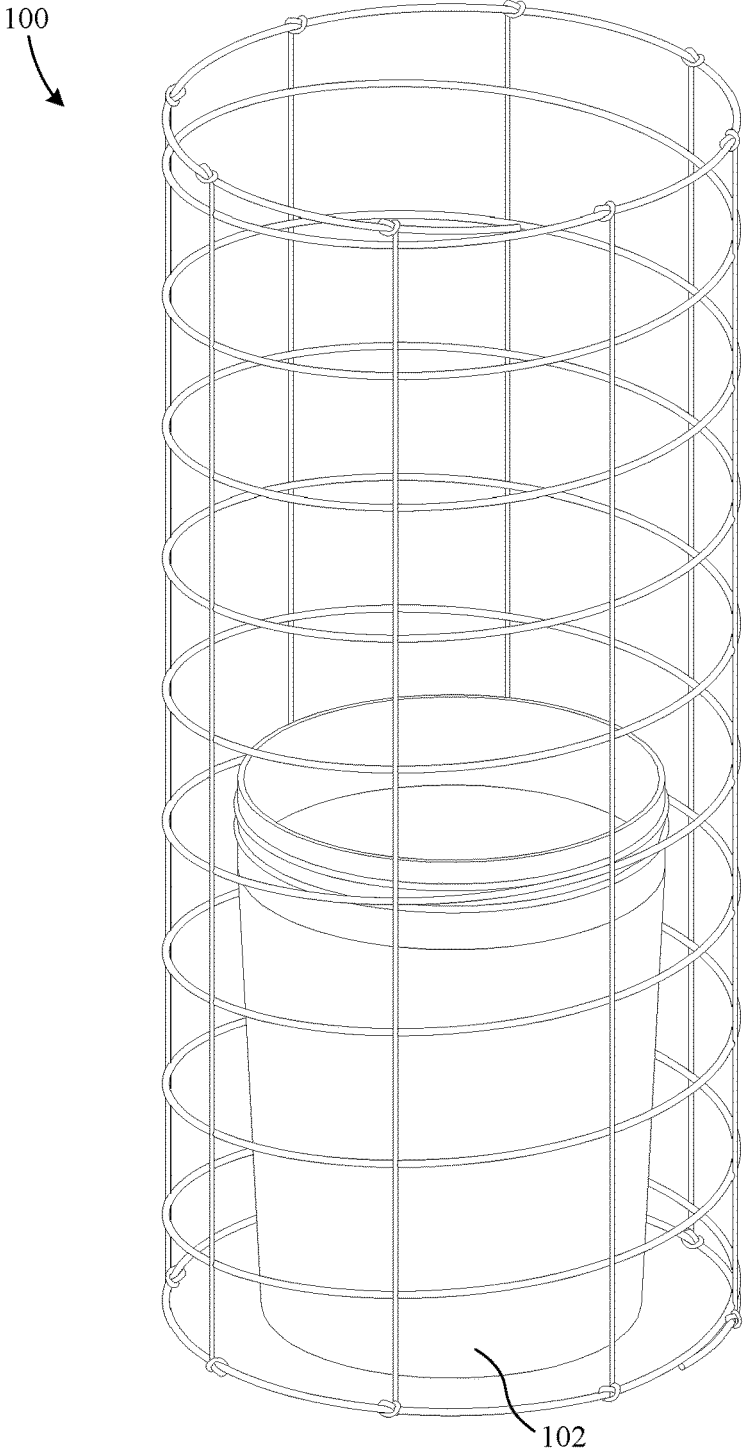

FIG. 1

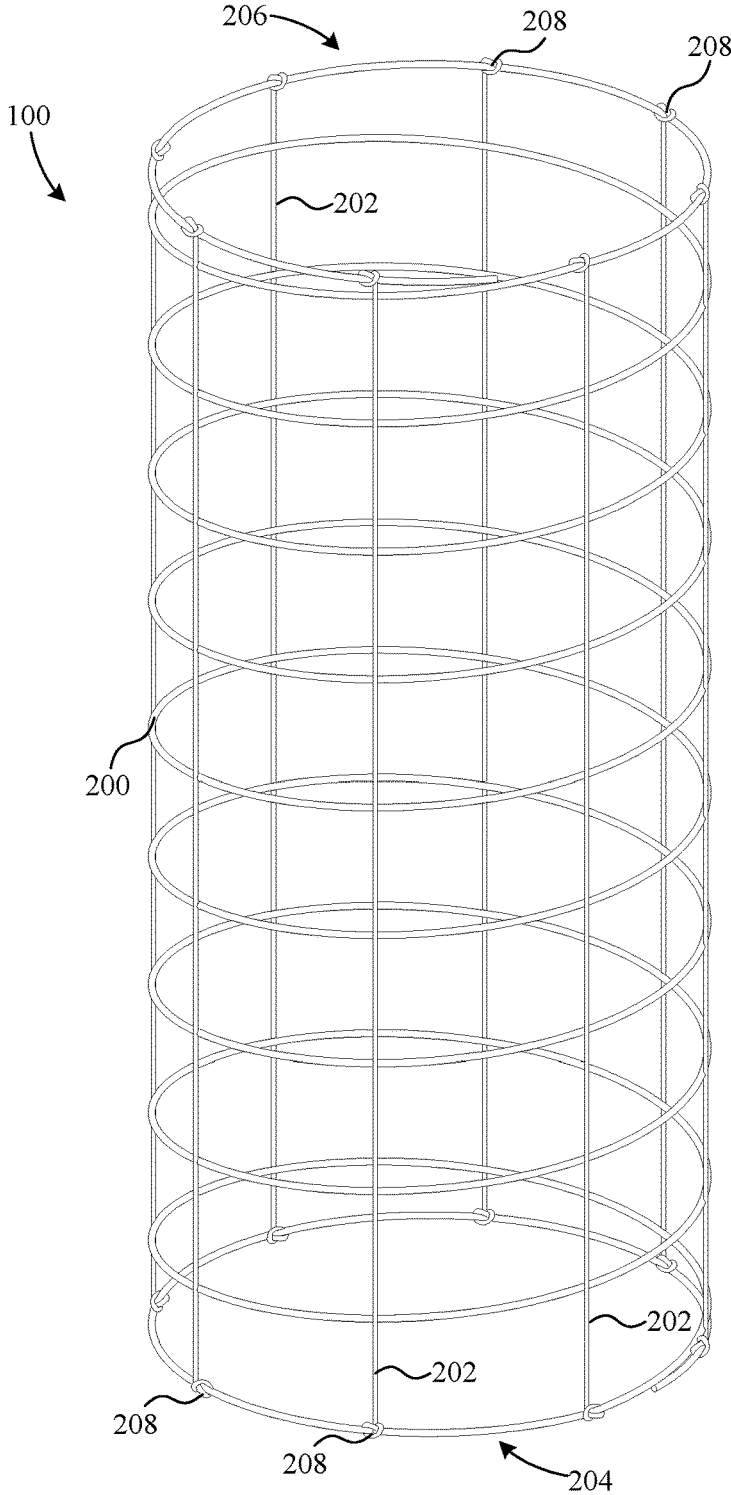

FIG. 2

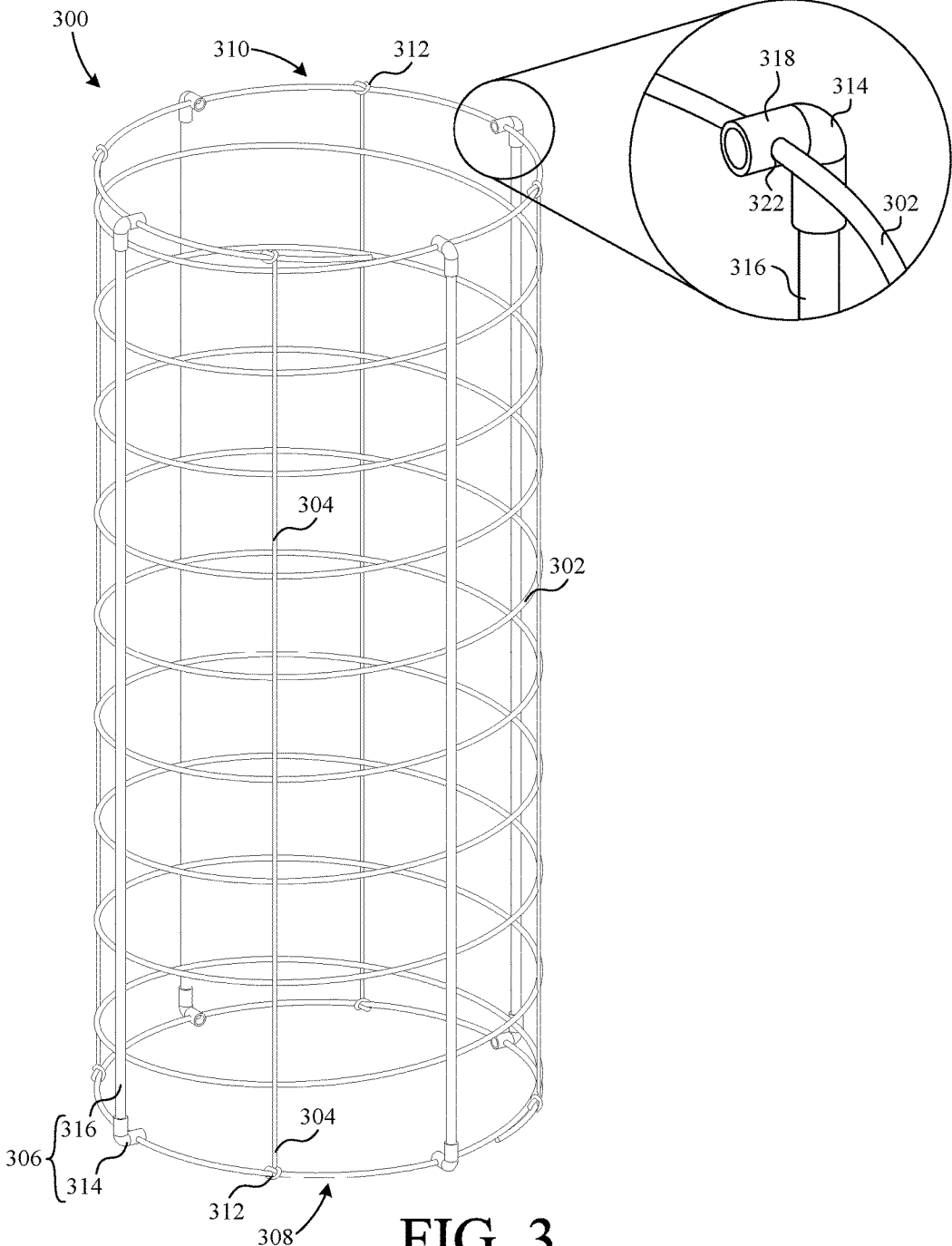

FIG. 3

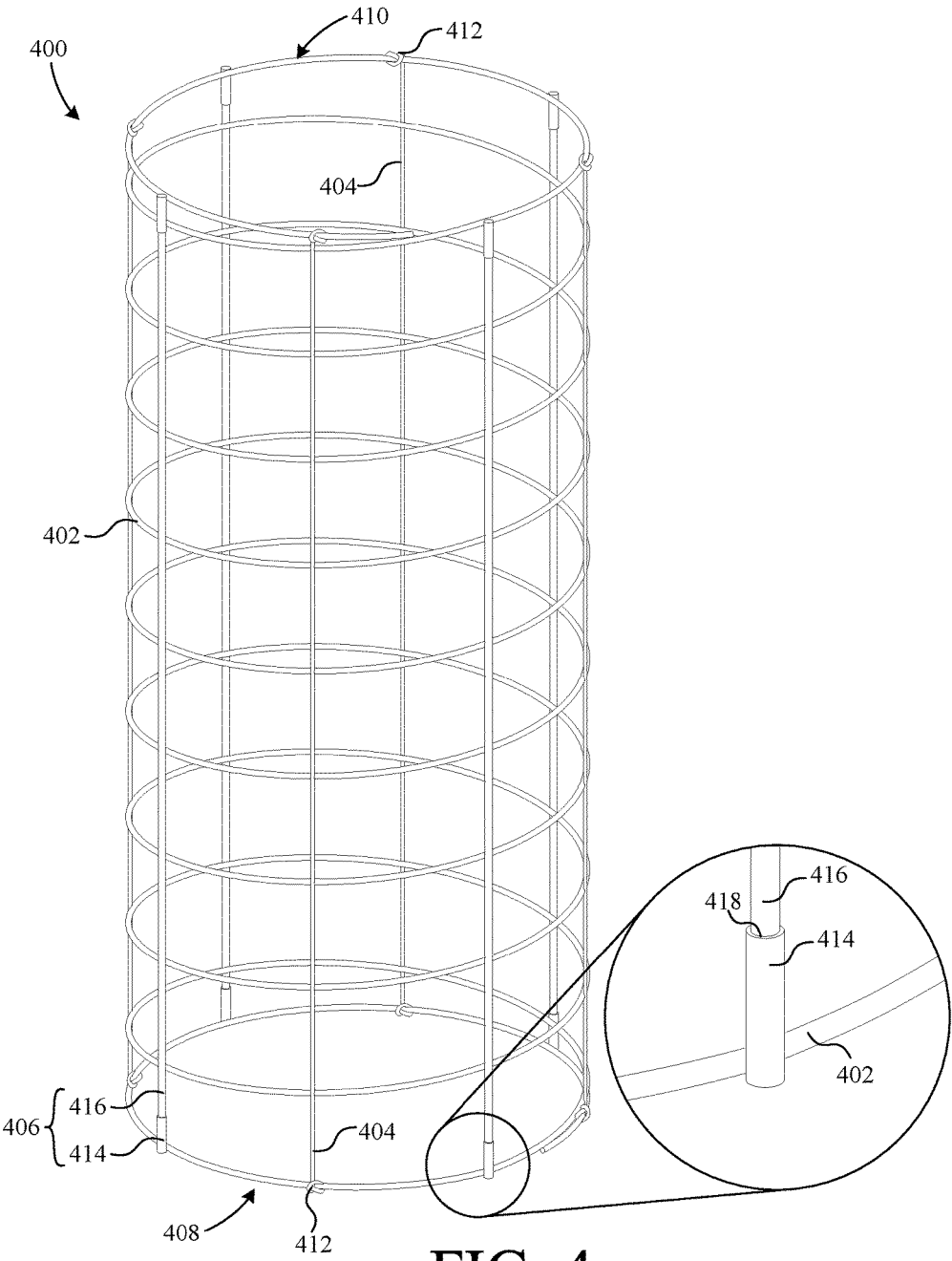

FIG. 4

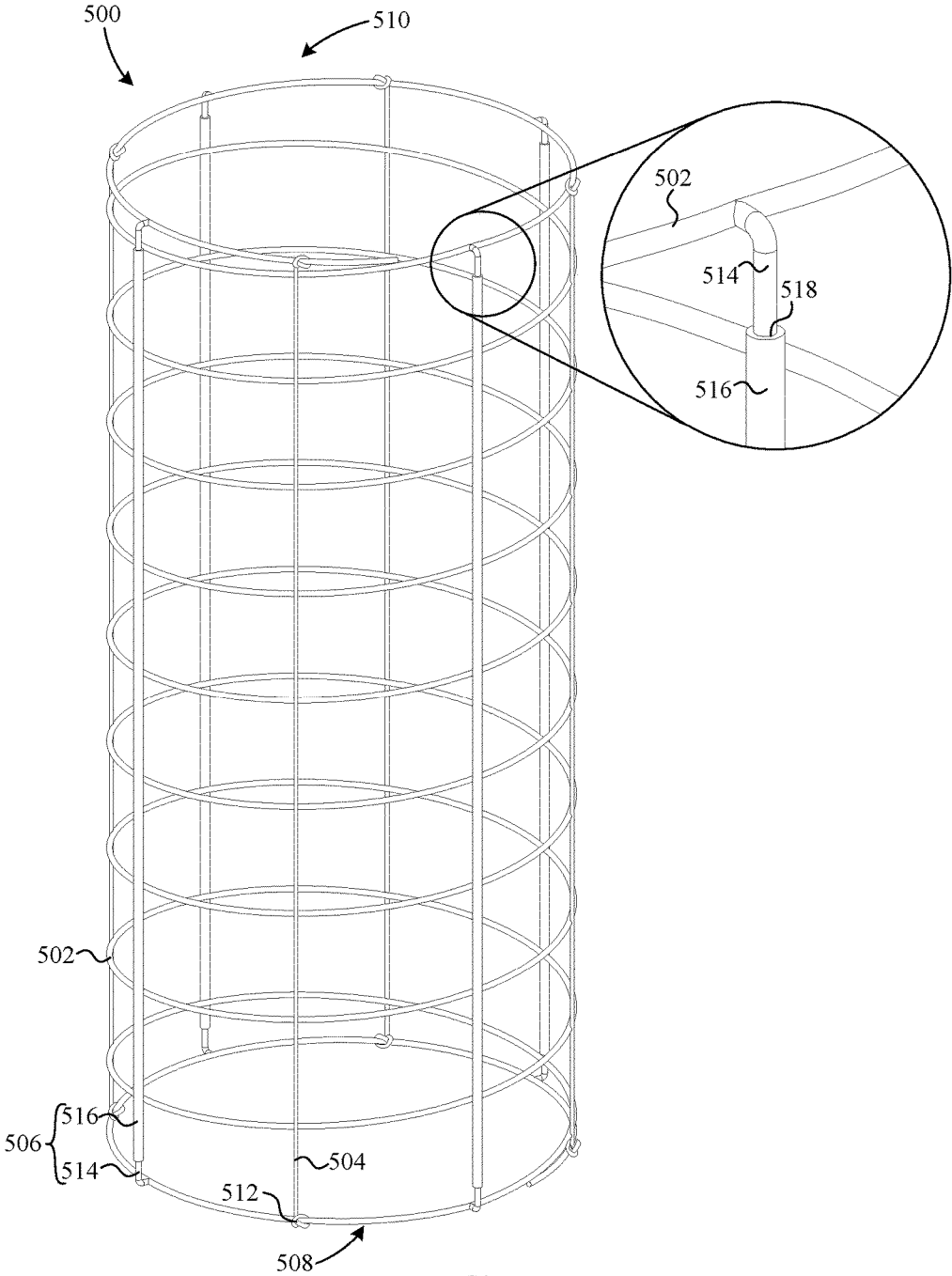

FIG. 5

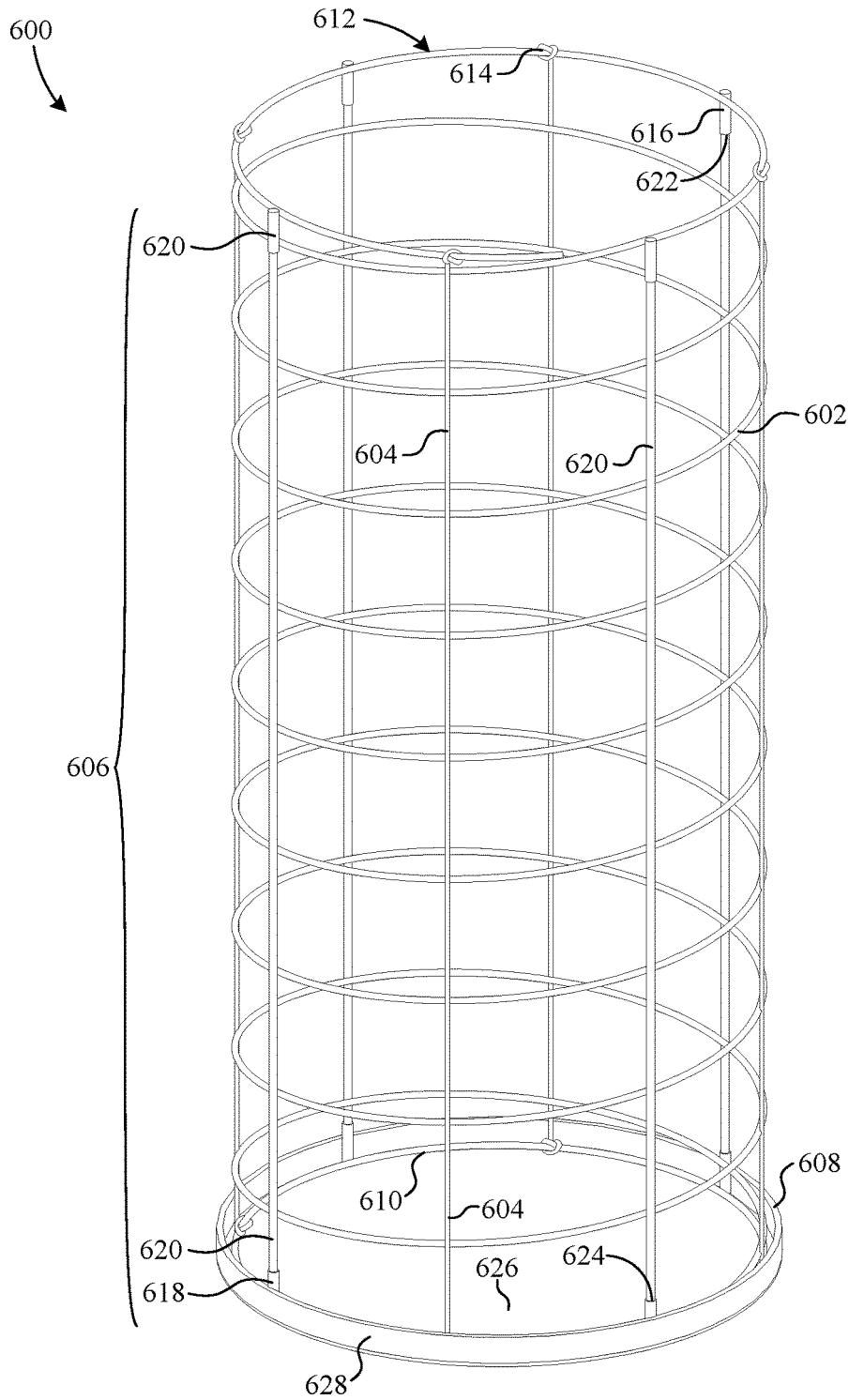

FIG. 6

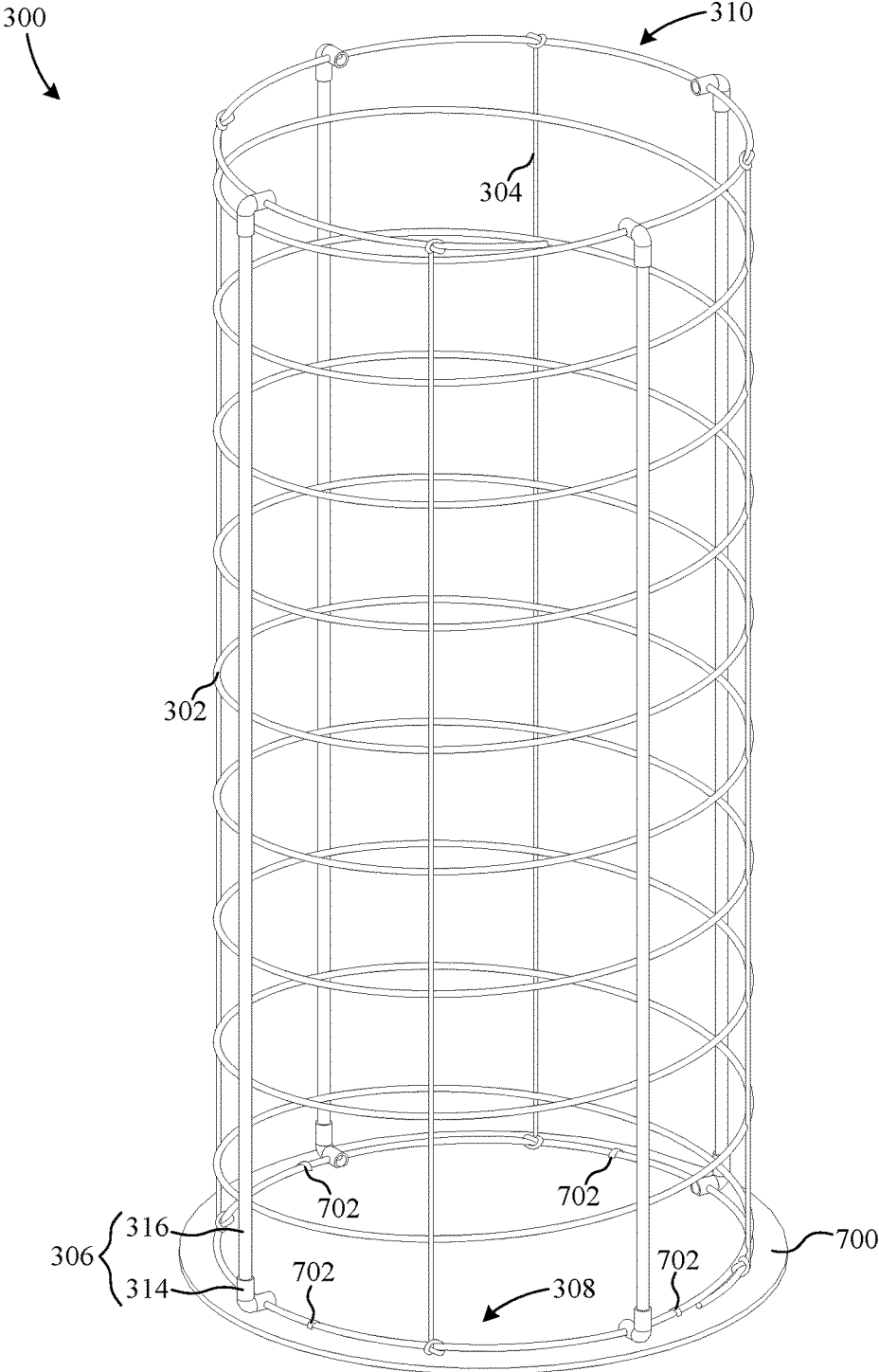

FIG. 7

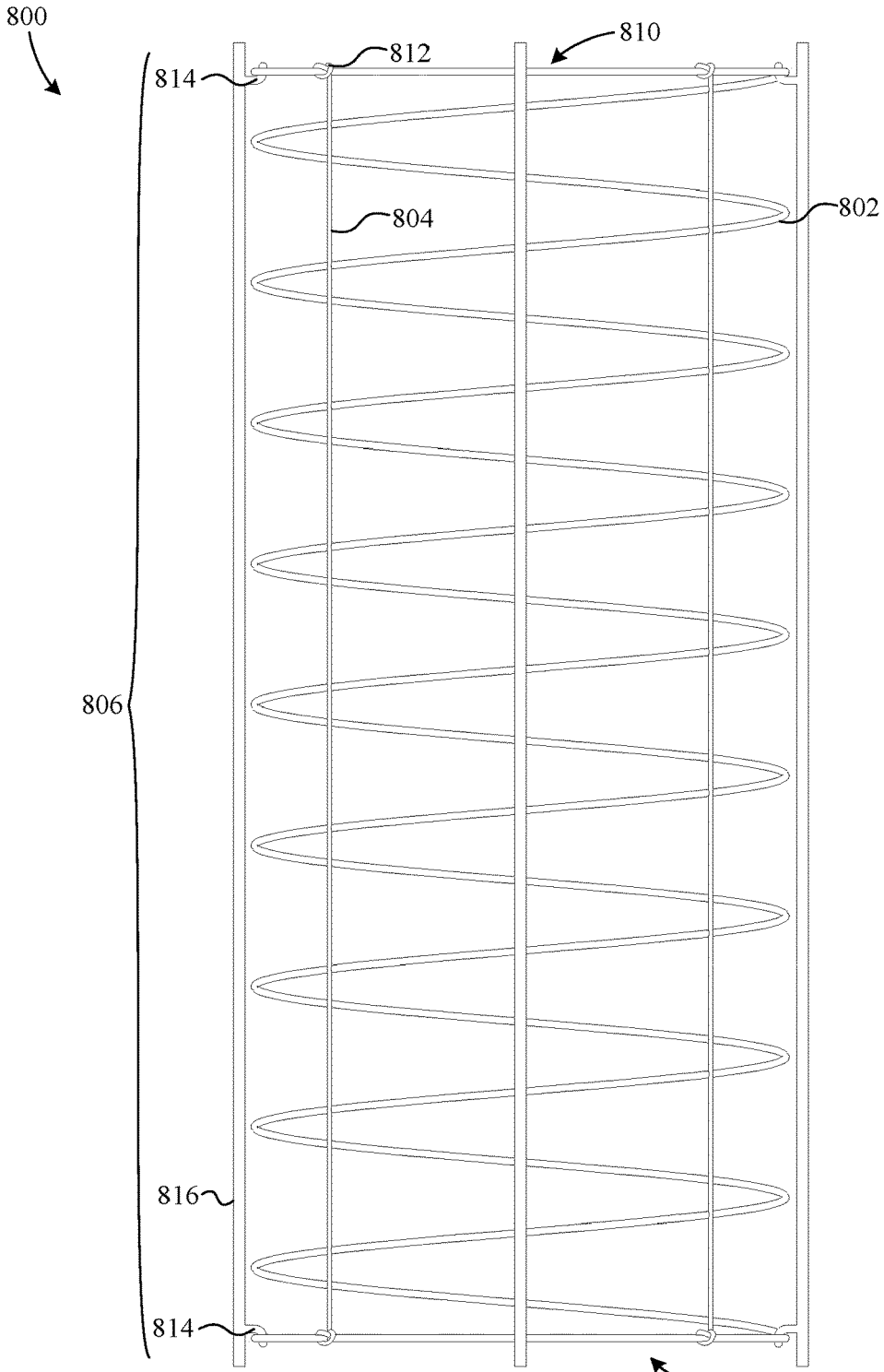

FIG. 8

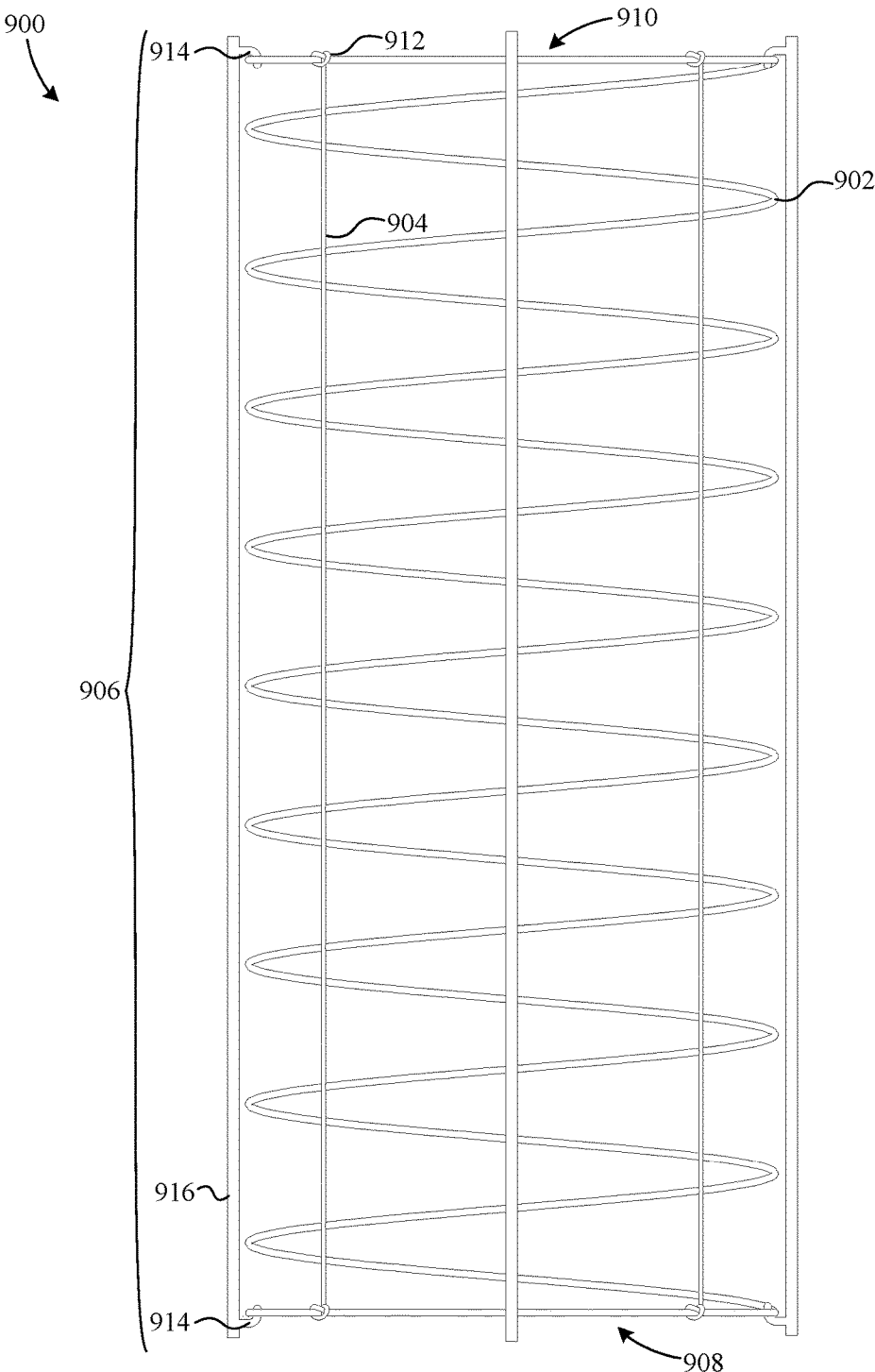

FIG. 9

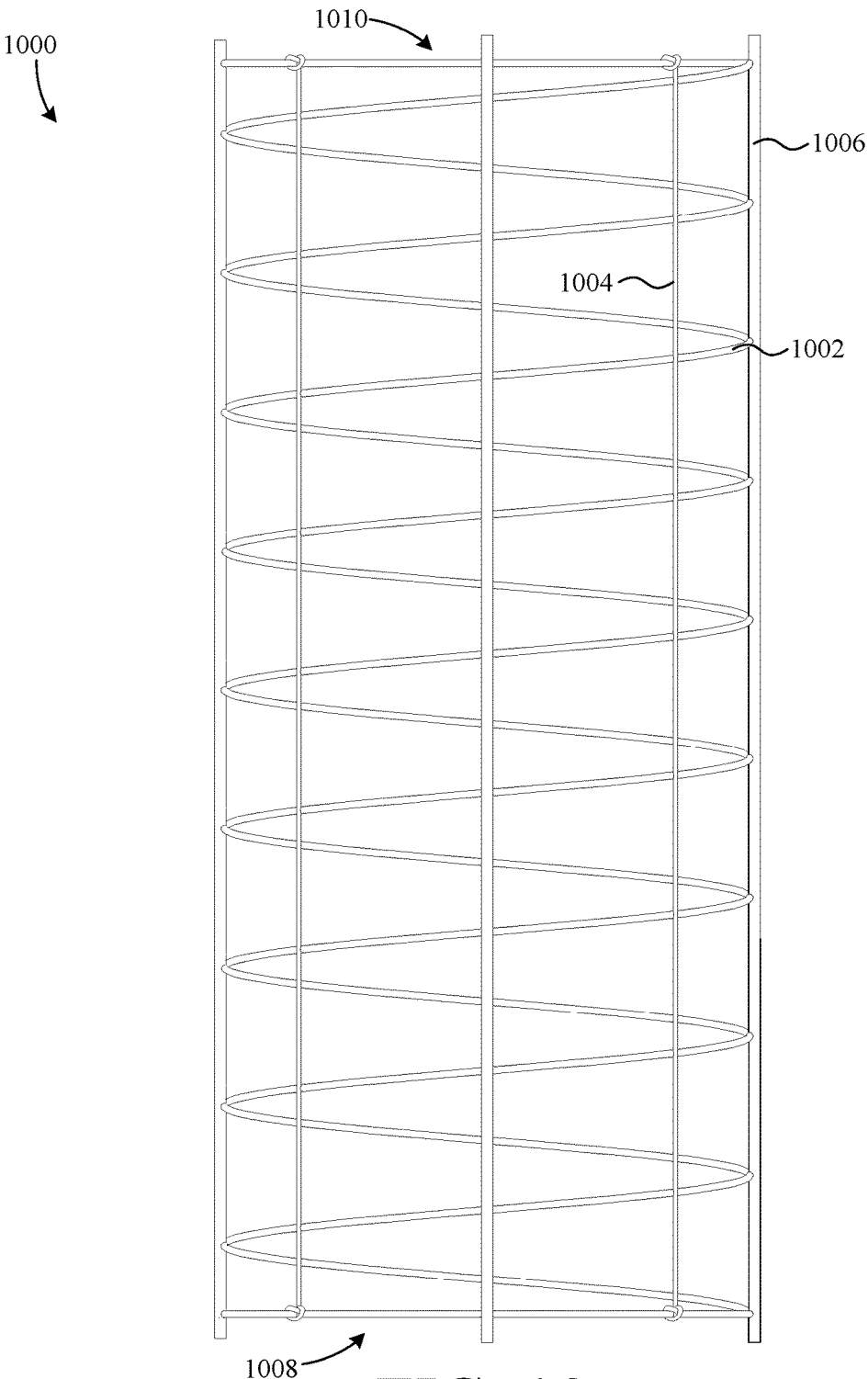

FIG. 10

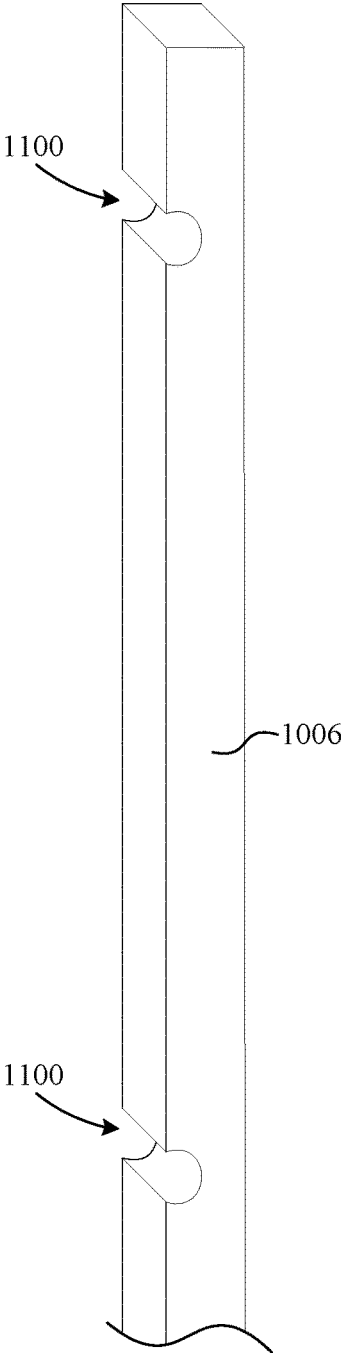

FIG. 11

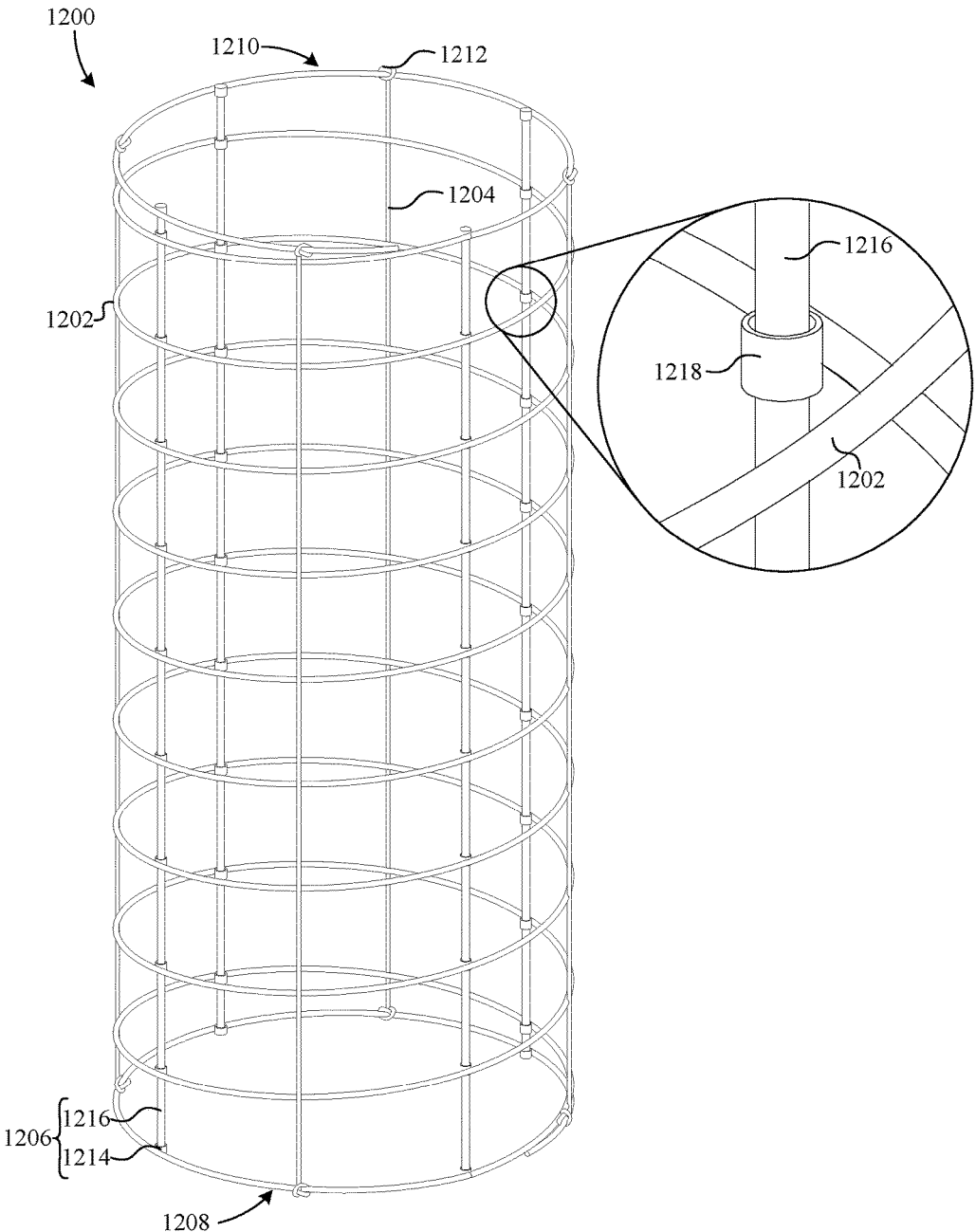

FIG. 12

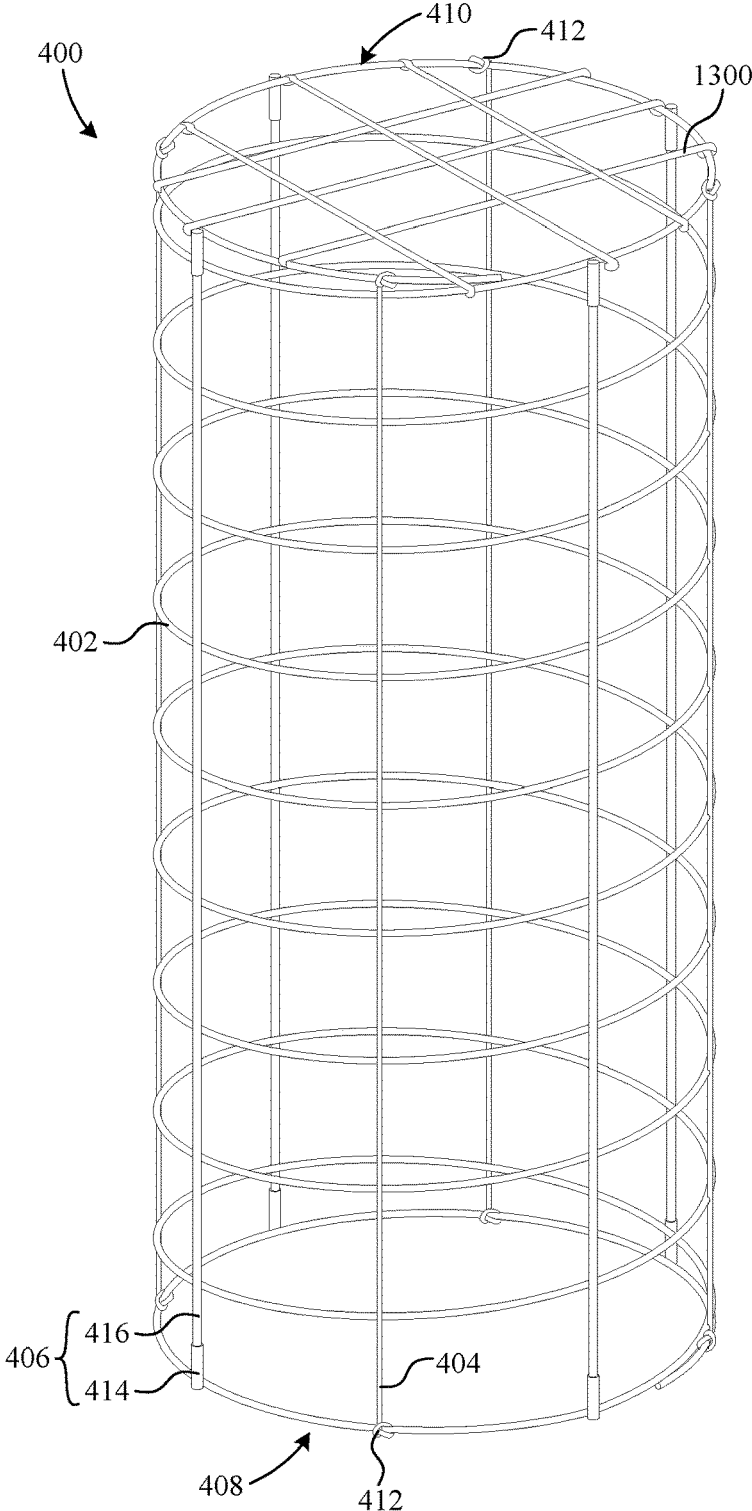

FIG. 13

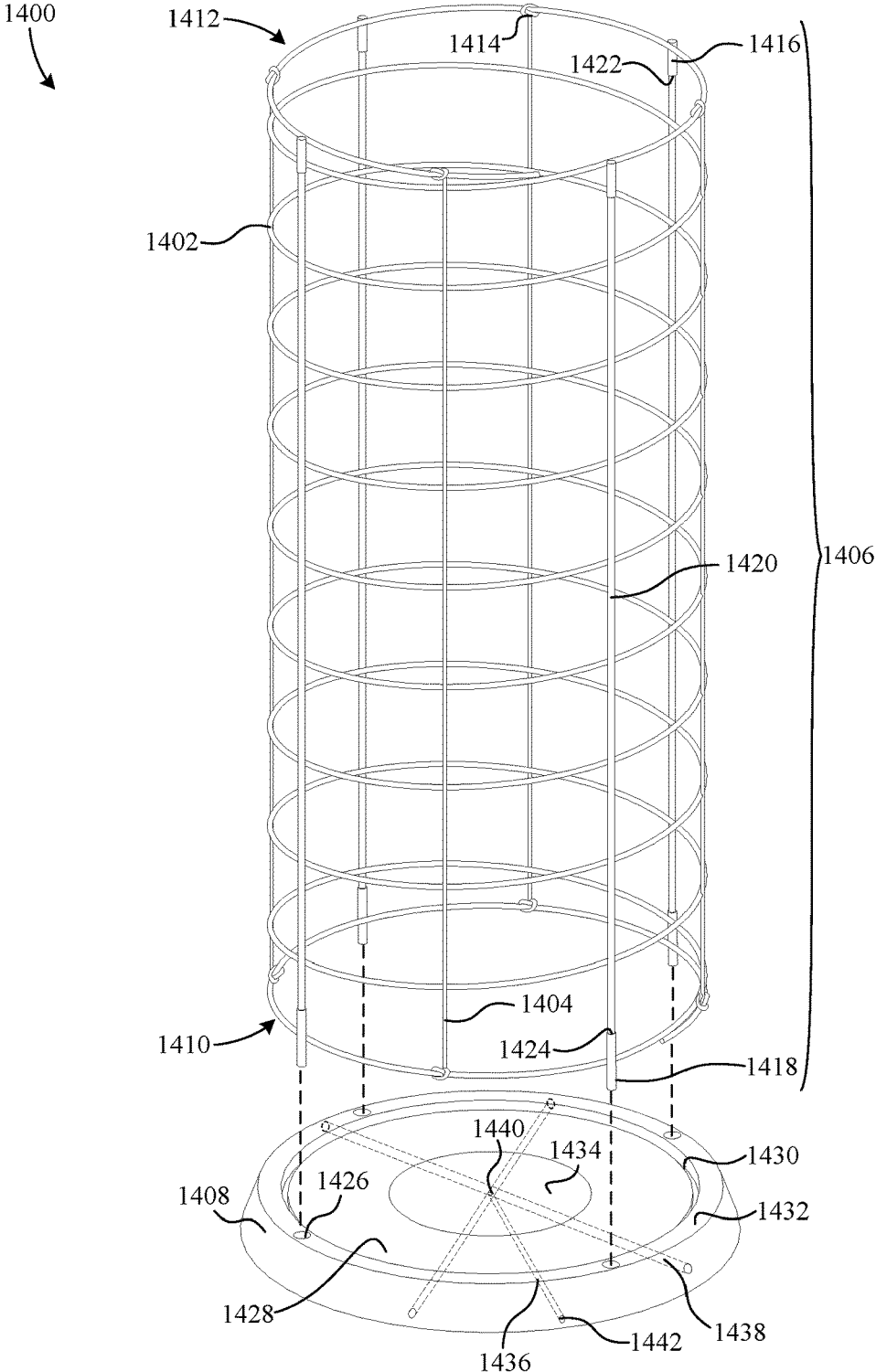

FIG. 14

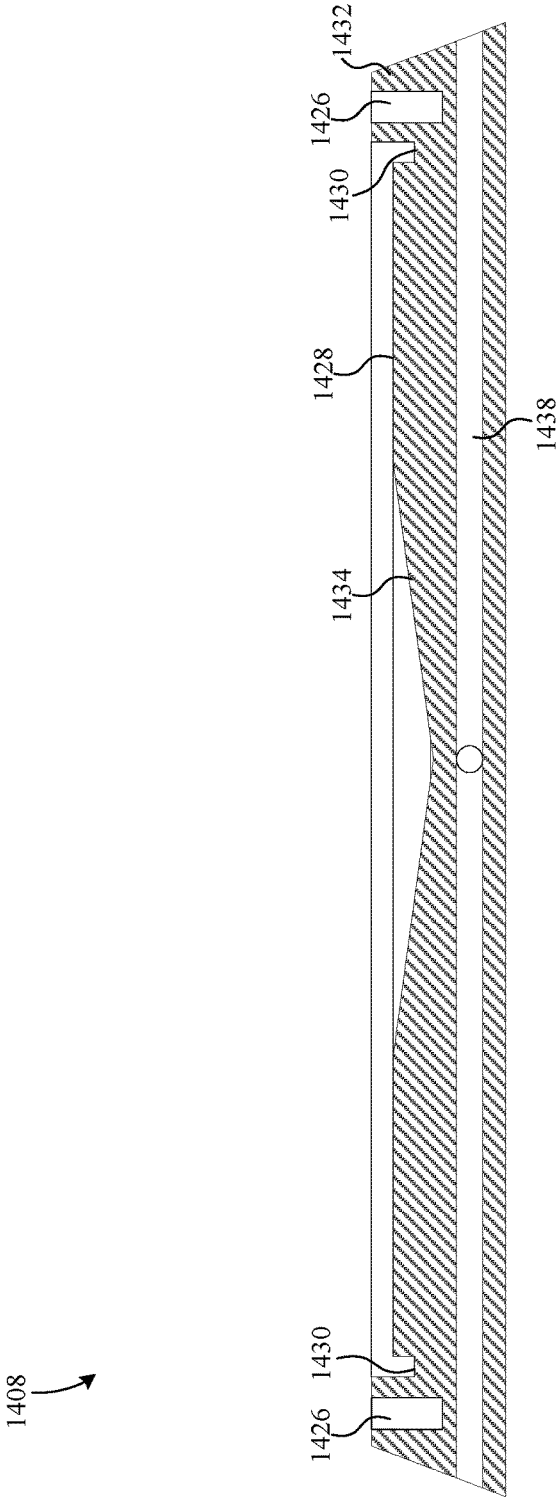

FIG. 15

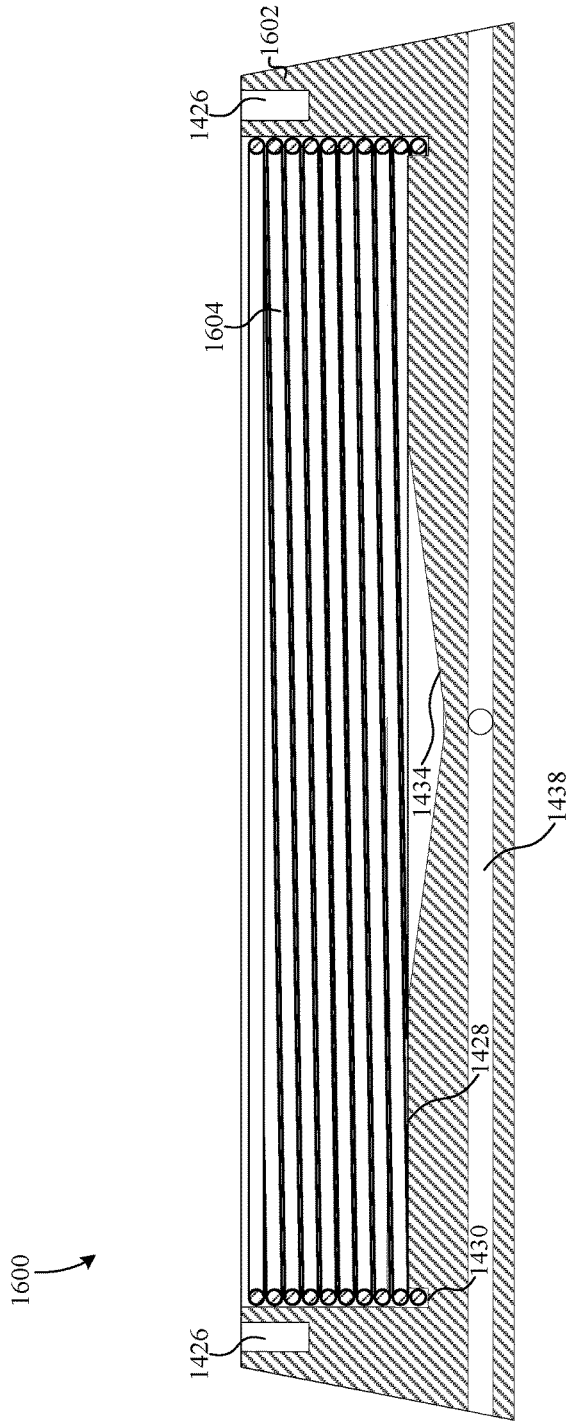

FIG. 16

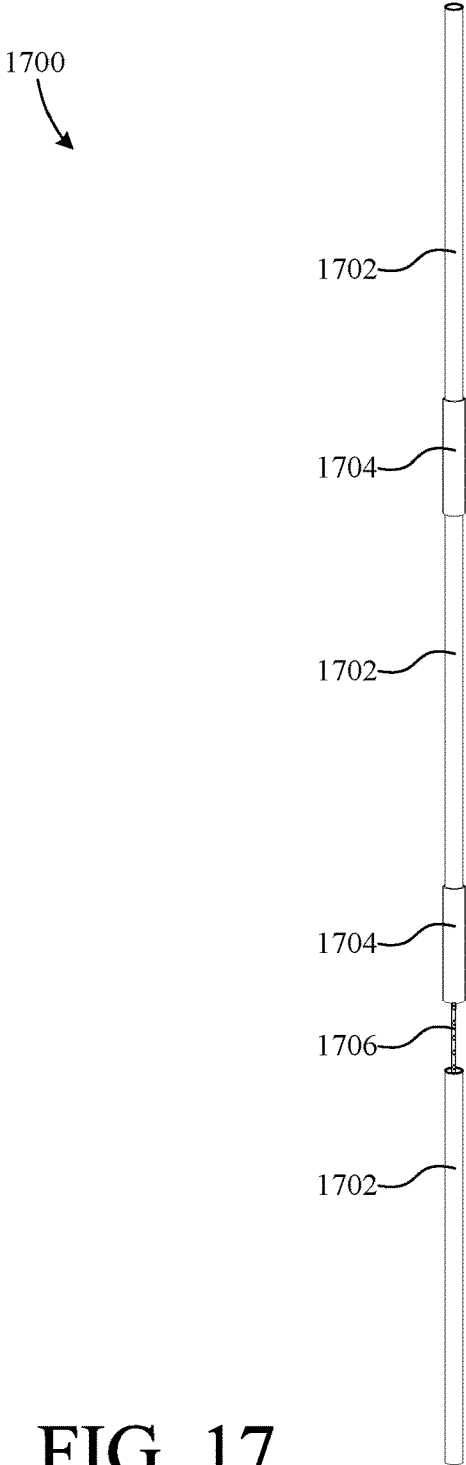

FIG. 17

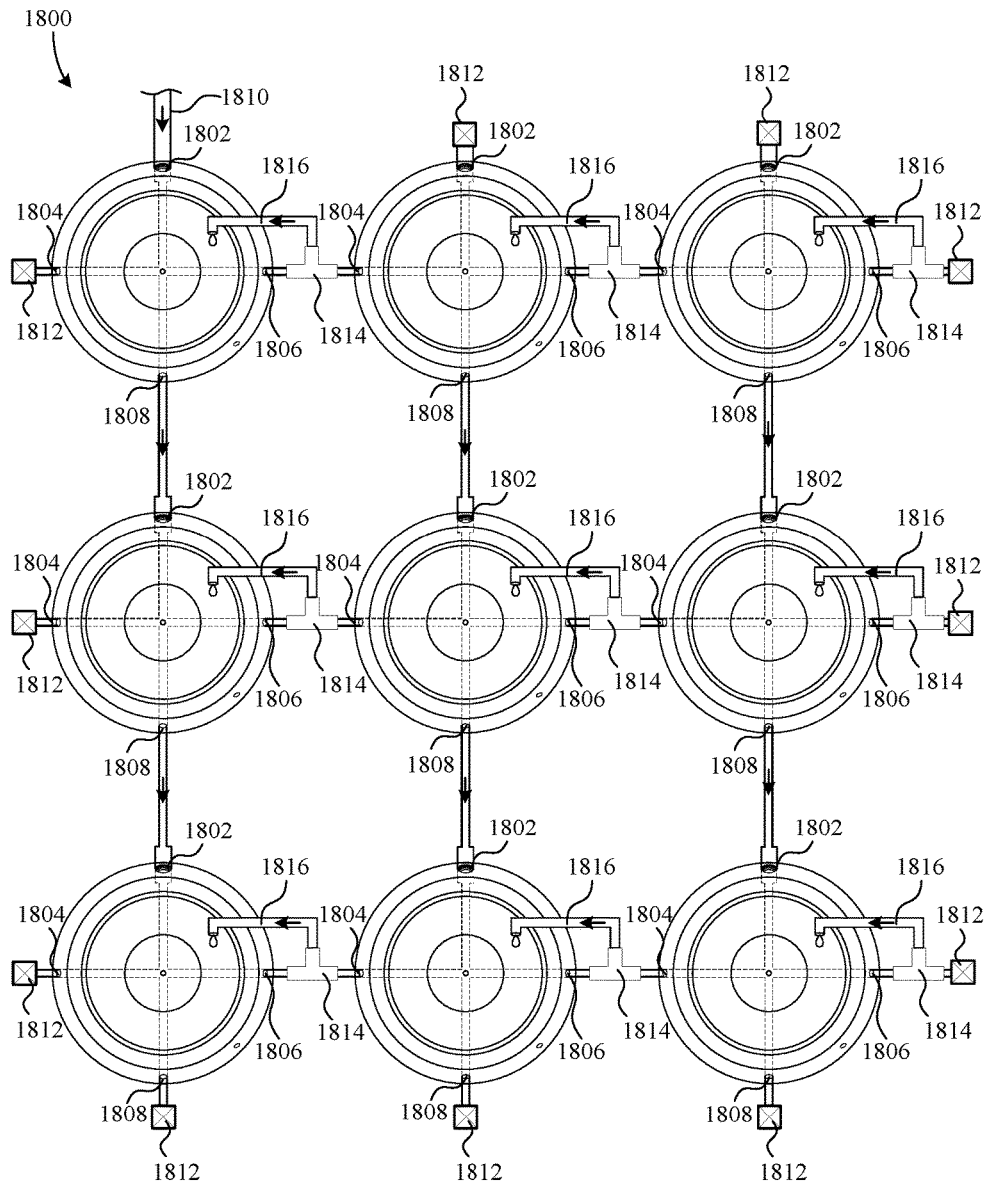

FIG. 18

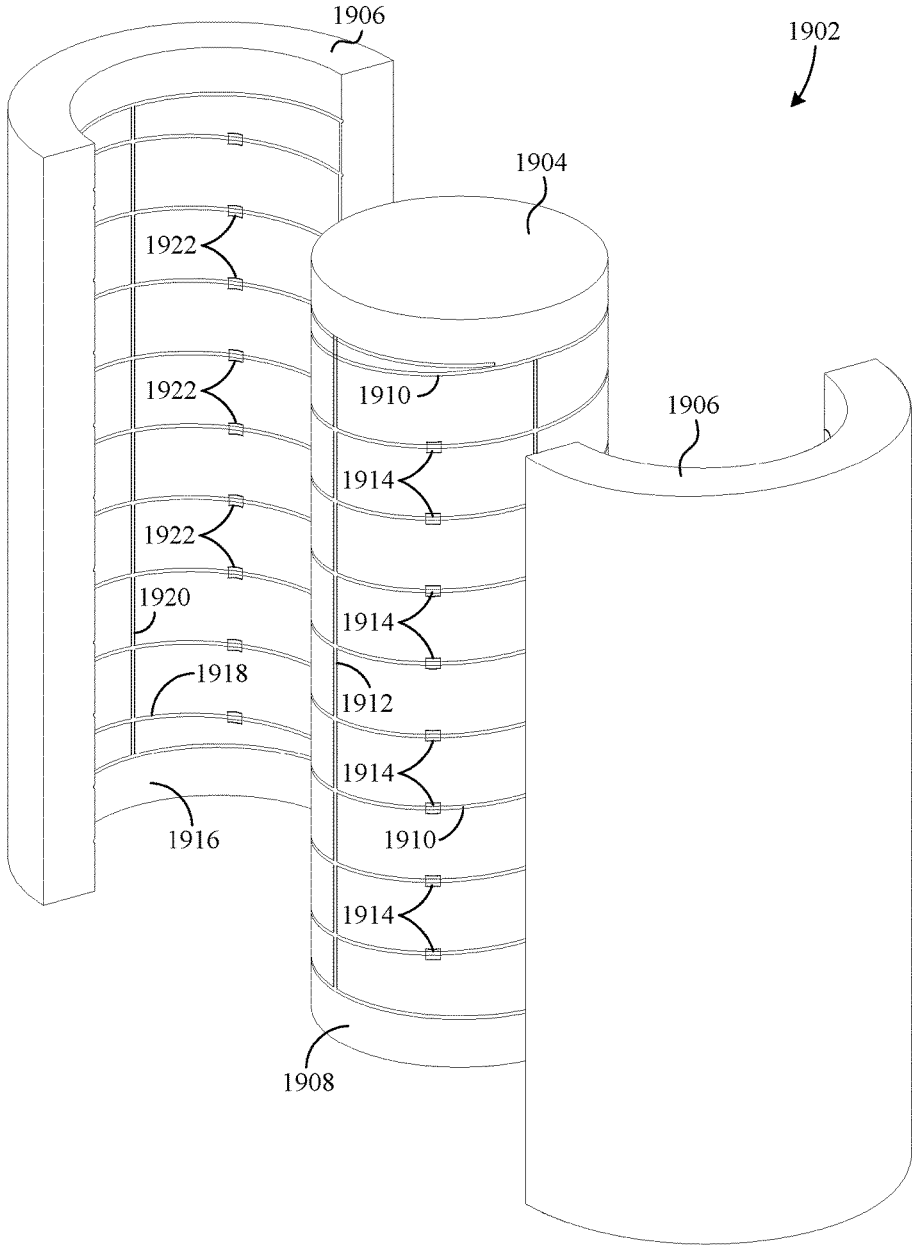

FIG. 19A

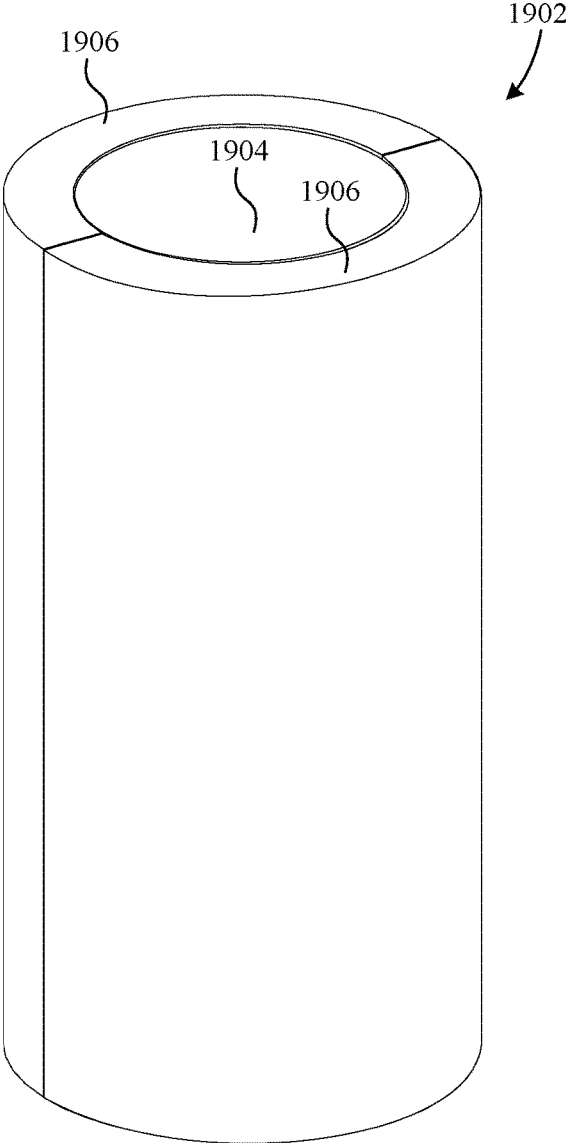

FIG. 19B

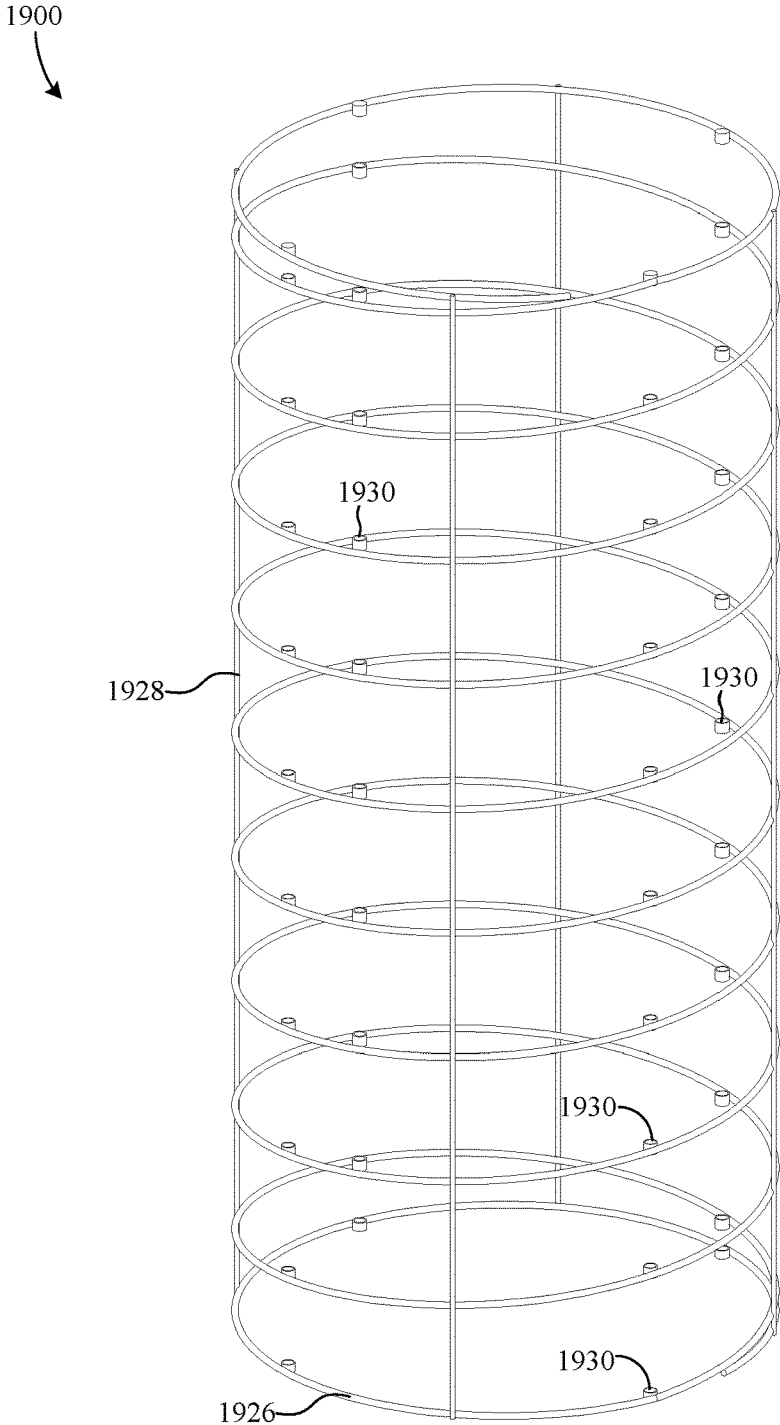

FIG. 19C

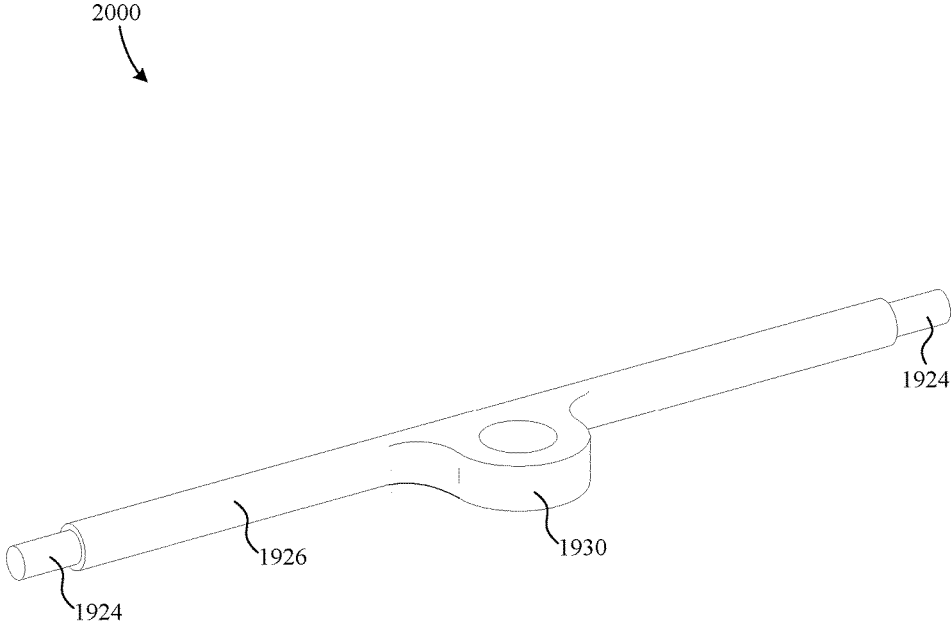

FIG. 20

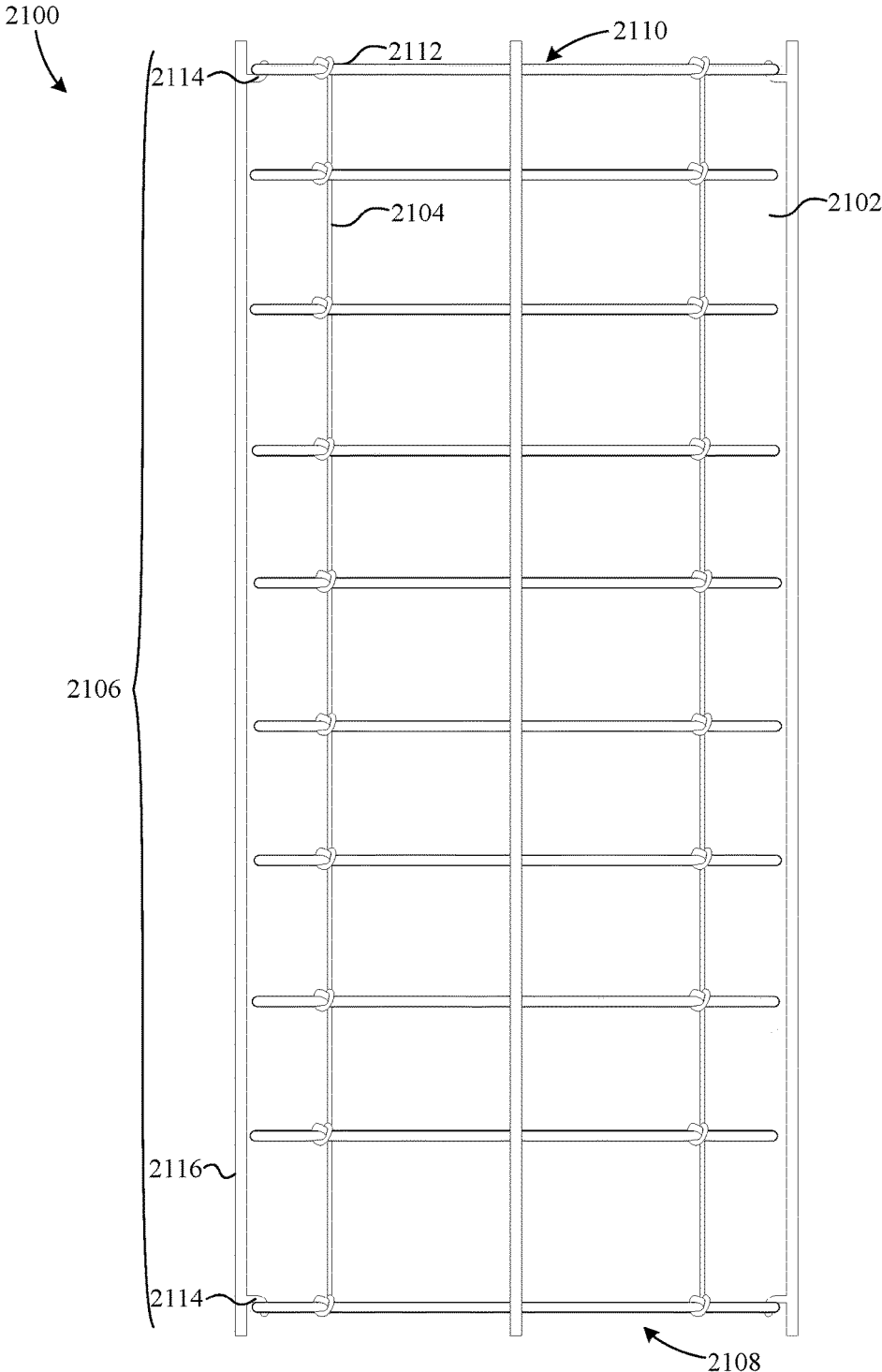

FIG. 21

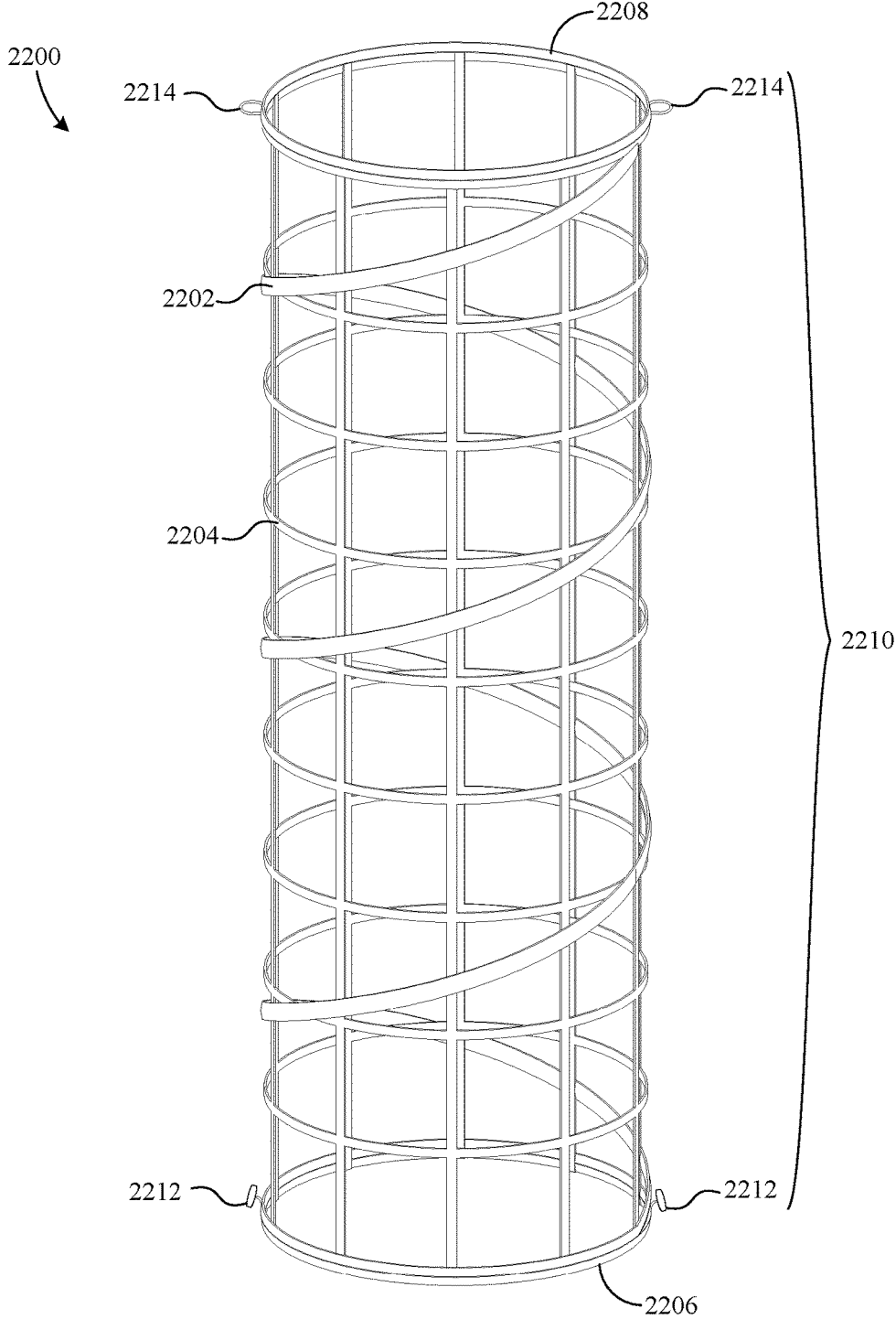

FIG. 22

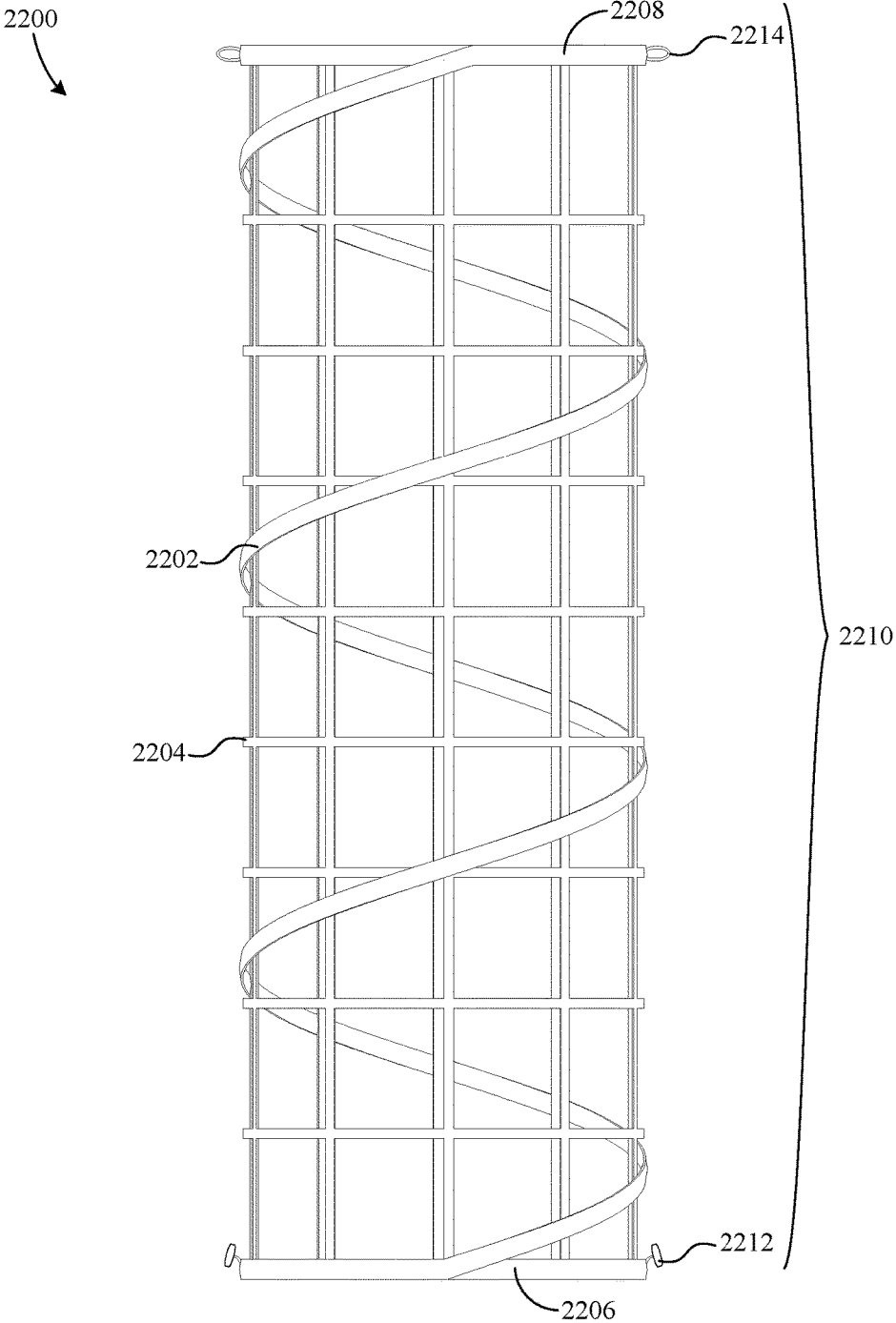

FIG. 23

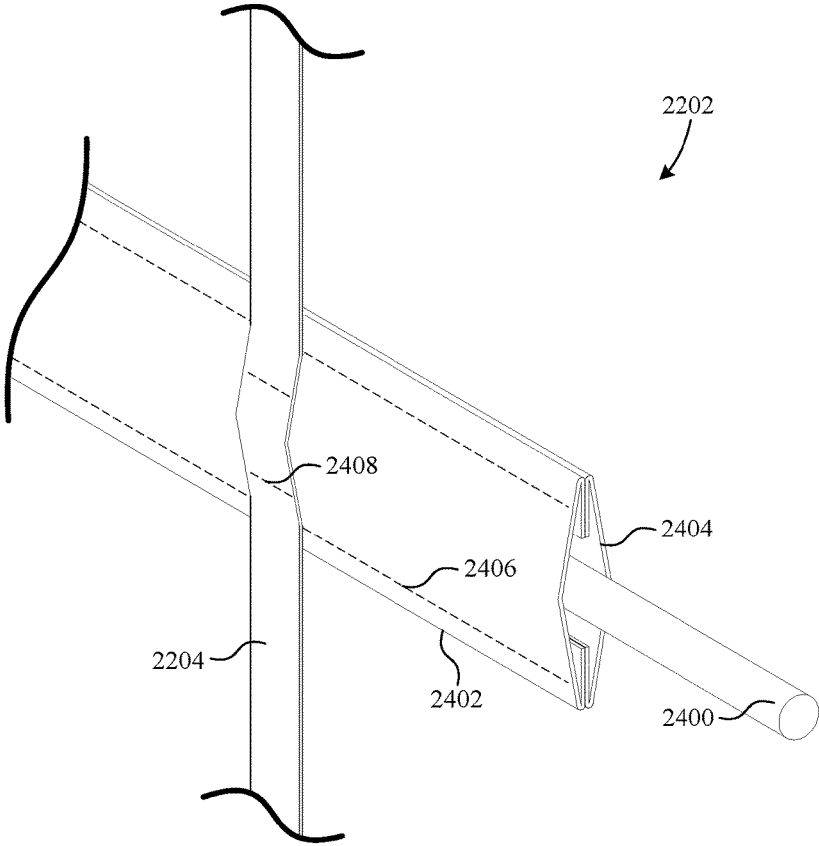

FIG. 24

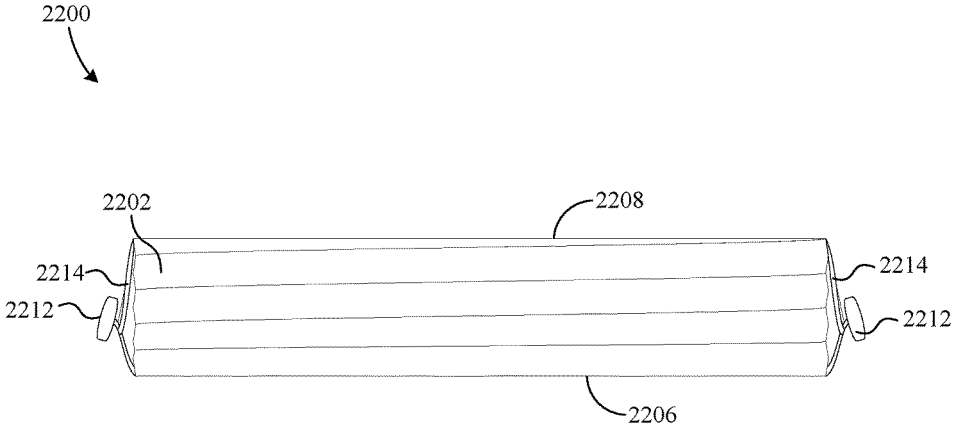

FIG. 25

COLLAPSIBLE PLANT SUPPORT**CROSS-REFERENCE TO RELATED APPLICATIONS**

This application is a continuation-in-part of co-pending U.S. patent application Ser. No. 14/251,038, filed Apr. 11, 2014 by at least one common inventor, which is incorporated herein by reference in its entirety.

BACKGROUND OF THE INVENTION**Field of the Invention**

This invention relates generally to gardening, and more particularly to plant support structures. Even more particularly, the invention relates to plant support structures adapted for use on hard, flat surfaces, and more particularly still with plant receptacles (i.e. buckets).

Description of the Background Art

In gardening, load supporting structures are often used to provide additional support to plants such as, for example, fruit bearing plants. Typically, such structures include a rigid grid-like structure that is placed near, or around, a plant in the early stages of growth. As the plant matures, it grows around and/or through the structure such that the structure supports a significant amount of the plant's weight.

One common type of load supporting structure is the conventional tomato cage. A conventional tomato cage typically includes a cylindrical wire grid and a plurality of relatively sharp stakes extending downward therefrom. The cylindrical wire grid includes a plurality of vertical and horizontal members welded together. The vertical members support the horizontal members and the horizontal members provide support to the plant. The stakes extend downward such that the tomato cage can be securely inserted into the soil surrounding the plant.

There are several disadvantages associated with conventional plant load supporting structures (e.g., a tomato cage). For example, conventional load supporting structures are relatively bulky and, therefore, difficult to store and/or ship. As another example, they have to be staked into the soil surrounding the plant. Consequently, conventional plant load supporting members are susceptible to tip when the weight of the plant becomes too great or unbalanced. As another consequence of having to be staked into the soil, conventional load supporting structures cannot be used in situations wherein soft soil is not available such as, for example, when the plant is growing out of hard mediums (e.g. hydroton). As yet another consequence, many plants are grown in pots and/or buckets where there is little room for stakes to be pressed into soil. Additionally, such pots and/or buckets typically rest on hard surfaces (e.g., decks, patios, etc.), which the stakes of the plant supporting structure cannot be driven into.

In efforts to make plant supporting structures less bulky, various collapsible plant supporting structures have been developed. For example, U.S. Pat. No. 4,860,489 (Bork) discloses an adjustable plant support that is collapsible so that it is easier to ship and/or store than conventional plant supporting structures. The adjustable plant support of Bork includes a coil that is supported by a pair of stakes that stick into the ground. The coil is coupled to the stakes via a set of clamps that also retain the coil in a decompressed position. When not being pulled apart in a decompressed position by

Although the adjustable plant support of Bork is less bulky and easier to ship than conventional plant supporting structures, it too has disadvantages. For example, the adjustable plant support of Bork requires a set of stakes to secure it to the ground. Consequently, the adjustable plant support of Bork suffers the aforementioned drawbacks associated with stakes. As another example, the adjustable plant support of Bork does not include vertical members that prevent horizontal movement of the plant.

What is needed, therefore, is a plant supporting structure that does not need to be staked to the ground. What is also needed is a plant supporting structure that provides horizontal support to plants. What is also needed is a plant support structure that can be used on hard and/or impenetrable surfaces.

SUMMARY

The present invention overcomes the problems associated with the prior art by providing a collapsible plant support structure. The invention facilitates the support of growing plants on hard or impenetrable surfaces. The support structure can be used on hard, flat surfaces and is collapsible for easy, compact storage.

An example collapsible plant support structure includes a collapsible coil, a bottom, and a plurality of retainers. The collapsible coil has an axis, a bottom end and a top end. The bottom is coupled to the bottom end of the collapsible coil and adapted to support the collapsible plant support on a flat horizontal surface with the axis perpendicular to the flat horizontal surface. The retainers are coupled to the bottom end of the collapsible coil and the top end of the collapsible coil, and are adapted to restrain the collapsible coil in a deployed position.

In an example embodiment, the plurality of retainers includes a plurality of vertical support structures, which remain entirely at or above the bottom of the collapsible plant support structure. Optionally, portions of the vertical support structures form at least a portion of the bottom of the collapsible plant support structure.

In example embodiments, each of the plurality of the support structures includes a first coil engaging feature, a second coil engaging feature, and a rigid member coupled between the first coil engaging feature and the second coil engaging feature. The first coil engaging feature is adapted to engage a portion of the collapsible coil at the top end of the collapsible coil, and the second coil engaging feature adapted to engage a portion of the collapsible coil at the bottom end of the collapsible coil. Optionally, the rigid members include a plurality of intermediate coil engaging features adapted to engage turns of the collapsible coil between the top end of the collapsible coil and the bottom of the collapsible coil. In one of the example embodiments, the collapsible coil tends to expand beyond the deployed position, and the support structures restrain the collapsible coil from expansion beyond the deployed position. In another of the example embodiments, the collapsible coil tends to contract from the deployed position, and the support structures restrain the collapsible coil from contracting from the deployed position.

In other disclosed embodiments, the collapsible plant support structure includes a plurality of vertical support engaging structures fixed to the collapsible coil. For example, a first set of vertical support structure engaging devices is coupled to the top end of the collapsible coil, each device being adapted to engage a top end of a respective one of the vertical support structures. In addition, a second set of

vertical support structure engaging features is coupled to the bottom end of the collapsible coil, each device being adapted to engage a bottom end of a respective one of the vertical support structures.

In some example embodiments, in addition to or instead of the vertical supports, the plurality of retainers includes a plurality of flexible elements coupled between the bottom end of the collapsible coil and the top end of the collapsible coil. In one such embodiment, the collapsible coil includes a plurality of helical turns, and at least one of the flexible elements is coupled to the bottom end of the collapsible coil, the top end of the collapsible coil, and every helical turn therebetween. In one such embodiment, each of the plurality of flexible elements is a cord (e.g., string, rope, braided wire, etc.).

In some of the example embodiments, the bottom end of the collapsible coil forms at least a portion of the bottom of the collapsible plant support structure. For example, several winds of the coil can be bound together to form a flat, circular bottom. Optionally, the inner diameter of the collapsible coil is greater than 12 inches, to accommodate the placement of a plant receptacle (e.g., a pot, five gallon bucket, etc.).

Optionally, the bottom of the collapsible plant support structure includes a base coupled to the bottom end of the collapsible coil. In some embodiments, the base is a rigid structure, whereby the collapsible plant support is stabilized by weight (e.g., a potted plant) placed on the base. Examples of a rigid base include, but are not limited to, a bar, a plate, and a pan. In other embodiments, the base is a flexible structure (e.g., a cord, a strap, etc.) coupled across the bottom end of the collapsible coil, whereby the collapsible plant support is stabilized by weight placed on the base.

In another example embodiment, a collapsible plant support structure includes a collapsible coil, a bottom, a plurality of vertical flexible elements, a plurality of vertical supports, and a plurality of coil engaging features. The collapsible coil has an axis, a bottom end and a top end. The bottom of the plant support structure is coupled to the bottom end of the collapsible coil and is adapted to support the collapsible plant support on a flat, horizontal surface with the axis perpendicular to the flat, horizontal surface. The vertical flexible elements are each coupled to the bottom end of the collapsible coil, the top end of the collapsible coil, and intermediate turns of the collapsible coil. The vertical supports are adapted to restrain the collapsible coil in a deployed position. The coil engaging features are adapted to couple the vertical supports to the collapsible coil. Optionally, the plant support structure additionally includes a flexible covering molded around the collapsible coil. The vertical flexible elements and the coil engaging features are also molded onto the collapsible coil.

A method of manufacturing a collapsible plant support structure is also disclosed. The method includes providing a collapsible coil having an axis, a bottom end and a top end. The method additionally includes molding a plurality of vertical flexible elements to the bottom end of the collapsible coil, the top end of the collapsible coil, and intermediate turns of the collapsible coil. A plurality of vertical supports adapted to restrain the collapsible coil in a deployed position is provided, and the method additionally includes molding a plurality of coil engaging features onto the collapsible coil. The coil engaging features are adapted to couple the vertical supports to the collapsible coil. In a particular example method, the vertical flexible elements and the coil engaging features are molded in a single molding process. Optionally,

a flexible covering can be molded around the collapsible coil as part of the single molding process.

BRIEF DESCRIPTION OF THE DRAWINGS

The present invention is described with reference to the following drawings, wherein like reference numbers denote substantially similar elements:

FIG. 1 is a perspective view of a plant support structure positioned around a bucket;

FIG. 2 is a perspective view of the plant support structure of FIG. 1;

FIG. 3 is a perspective view of a plant support structure according to another embodiment of the present invention;

FIG. 4 is a perspective view of a plant support structure according to another embodiment of the present invention;

FIG. 5 is a perspective view of a plant support structure according to another embodiment of the present invention;

FIG. 6 is a perspective view of a plant support structure according to another embodiment of the present invention;

FIG. 7 is a perspective view of the plant support structure of FIG. 3 according to another embodiment of the present invention;

FIG. 8 is a side view of a plant support structure according to another embodiment of the present invention;

FIG. 9 is a side view of a plant support structure according to another embodiment of the present invention;

FIG. 10 is a side view of a plant support structure according to another embodiment of the present invention;

FIG. 11 is a perspective view of a vertical support structure of the plant support structure of FIG. 10.

FIG. 12 is a perspective view of a plant support structure according to another embodiment of the present invention;

FIG. 13 is a perspective view of the plant support structure of FIG. 4 according to another embodiment of the present invention;

FIG. 14 is a perspective view of a plant support structure according to another embodiment of the present invention;

FIG. 15 is a cross-sectional side view of a plant receptacle receiving element of the plant support structure of FIG. 1400;

FIG. 16 is a cross-sectional view of a plant receptacle receiving element according to another embodiment of the present invention;

FIG. 17 is a perspective view of a collapsible vertical support structure according to another embodiment of the present invention; and

FIG. 18 is a top view of an array of plant receptacle receiving elements;

FIG. 19A is a perspective view of an insert mold in an open position;

FIG. 19B is a perspective view of the insert mold of FIG. 19A in a closed position;

FIG. 19C is a perspective view of a collapsible plant support structure formed in the mold of FIG. 19A;

FIG. 20 is a perspective view of a section of the collapsible plant support structure of FIG. 19C;

FIG. 21 is a side view of a collapsible plant support structure according to another embodiment of the present invention;

FIG. 22 is a perspective view of a collapsible plant support structure according to yet another embodiment of the present invention;

FIG. 23 is a side view of the collapsible plant support structure of FIG. 22;

FIG. 24 is a perspective view of a section of the coil and mesh of the collapsible plant support structure of FIG. 22; and

FIG. 25 is a side view of the collapsible plant support structure of FIG. 22 in a compressed state.

DETAILED DESCRIPTION

The present invention overcomes the problems associated with the prior art, by providing a collapsible plant support structure that is adapted to rest on a substantially flat surface. In the following description, numerous specific details are set forth (e.g., number of coils, types of vertical support structures, etc.) in order to provide a thorough understanding of the invention. Those skilled in the art will recognize, however, that the invention may be practiced apart from these specific details. In other instances, details of well-known coil manufacturing practices (e.g., wire extrusion, wire bending/welding, etc.) and components have been omitted, so as not to unnecessarily obscure the present invention.

FIG. 1 shows perspective view of a collapsible plant support structure 100 having a bucket 102 disposed therein. Plant support structure 100 is operative to provide additional support to plants growing out of bucket 102. As shown, plant support structure 100 is adapted to rest on a flat surface on which bucket 102 is also supported. This is particularly advantageous in scenarios such as, for example, when using bucket 102 to grow plants indoors wherein plant support structure 100 and bucket 102 would rest on a floor. Unlike prior art plant supports, collapsible plant support structure 100 does not require being staked into underlying soil. That is, plant support structure 100 is self-supporting on planar surfaces.

FIG. 2 shows a perspective view of collapsible plant support structure 100 in an open (deployed) position. In this particular embodiment, collapsible plant support structure 100 includes a collapsible coil 200 and plurality of vertical structures 202 coupled thereto. Collapsible coil 200 is essentially a large metal wire coil having a somewhat low resistance to compression such that it can be easily compressed to a very small size during shipping and/or storage. Of course, coil 200 also has a resistance to compression sufficient to support plants without collapsing. Coil 200 includes a bottom region 204 and an opposite top region 206. Bottom region 204 is defined by a portion of coil 200 that is wound in a plane such that bottom region 204 is adapted to rest on a flat surface (i.e. floor). In this example, vertical structures 202 are operative to limit horizontal movement of plant branches extending out of collapsible plant support structure 100. This is beneficial in that the weight of the plant is more evenly distributed about collapsible plant support structure 100 when branches are not free to move horizontally. In this example, vertical structures 202 are formed from individual pieces of string that are each tied into knots 208 attached to both bottom region 204 and top region 206. Although each piece of string is tied to coil 200 with two knots 208, each of vertical structures 202 could be tied to each turn of coil 200 to further limit relative horizontal movement between vertical structures 202 and coil 200. In other words, each contact point between coil 200 and vertical structures 202 would be coupled via a knot.

In this embodiment, vertical structures 202 also serve as retainers, because they prevent coil 200 from expanding beyond its intended deployed position. In other words, vertical structures 202 restrain coil 202 in its deployed position.

FIG. 3 shows a perspective view of a collapsible plant support structure 300 according to another embodiment of the present invention. Plant support structure 300 provides additional support to plants, beyond that which would be provided by the previous embodiment. Plant support structure 300 includes a collapsible coil 302, a plurality of vertical structures 304, and a plurality of vertical support structures 306. Collapsible coil 302 is substantially similar to coil 200 in that the only difference is that coil 302 is naturally in a collapsed state when not being held open by vertical support structures 306. In other words, coil 200 (FIG. 2) is naturally open tends toward expansion), but has to be secured in a collapsed position during storage. In contrast, coil 302 is naturally in a collapsed position (tends toward contraction), but requires being held open by vertical support structures 306 during operation. Thus, vertical support structures 306 serve as retainers, restraining coil 302 in a deployed position.

Coil 302 includes a bottom region 308 and an opposite top region 310. Bottom region 308 is defined by a portion of coil 302 that is wound in a plane such that bottom region 308 is adapted to rest on a flat surface (i.e. floor). In this example, vertical structures 304 are operative to limit horizontal movement of plant branches extending out of collapsible plant support structure 300. This is beneficial in that the weight of the plant is more evenly distributed about collapsible plant support structure 300 when branches are not free to move horizontally. In this example, vertical structures 304 are formed from individual pieces of string that are each tied into knots 312 attached to both bottom region 308 and top region 310.

Each of vertical support structures 306 includes two coil engaging features 314 and a columnar structure 316 disposed therebetween. In this example, coil engaging features 314 are plastic elbow couplings having a first end 318 coupled to coil 302 and a second end 320 coupled to a respective one of columnar structures 316. Each first end 318 of coil engaging features 314 includes an aperture 322 through which coil 302 is disposed. Each second end 320 is friction fit to a respective end of a respective one of columnar structures 316. Each of columnar structures 316 is a rigid pole or tube formed from some suitable material such as, for example, plastic, wood, fiberglass, etc. The rigidity and strength of columnar structures 316 is such that they do not buckle under the spring force of coil 302 and the weight of a plant growing out of collapsible plant support structure 300. In addition to providing vertical support, columnar structures 316 also provide horizontal support to plants growing from plant support structure 300. Collapsible plant support structure 300 can be stored simply by sliding columnar structures out of second ends 320 of coil engaging features 314. With coil engaging features 314 removed, coil 302 collapses down into a small form factor for storage, shipping, etc.

FIG. 4 shows a perspective view of a collapsible plant support structure 400 according to another embodiment of the present invention. Plant support structure 400 is operative to provide additional support to plants. Plant support structure 400 includes a collapsible coil 402, a plurality of vertical structures 404, and a plurality of vertical support structures 406. Collapsible coil 402 is substantially similar to coil 302 in that it is naturally in a collapsed state when not being held open by vertical support structures 406. Coil 402 includes a bottom region 408 and an opposite top region 410. Bottom region 408 is defined by a portion of coil 402 that is wound in a plane such that bottom region 408 is adapted to rest on a flat surface. In this example, vertical

structures **404** are operative to limit horizontal movement of plant branches extending out of collapsible plant support structure **400**, as in the previously described embodiment.

Each of vertical support structures **306** includes two coil engaging features **414** and a columnar structure **416** disposed therebetween. In this example, coil engaging features **414** are tubular rigid female couplings attached to coil **402** by some suitable means such as, for example, a tack weld. Each of coil engaging features **414** includes an open end **418** adapted to receive a respective end of a respective one of columnar structures **416**. Each open end **418** is friction fit around a respective end of a respective one of columnar structures **416**. Each of columnar structures **416** is a rigid pole or tube formed from some suitable material such as, for example, plastic, wood, fiberglass, etc. The rigidity and strength of columnar structures **416** is such that they do not buckle under the spring force of coil **402** and the weight of a plant growing out of collapsible plant support structure **400**. In addition to providing vertical support, columnar structures **416** also provide horizontal support to plants growing from plant support structure **400**. Collapsible plant support structure **400** can be stored simply by sliding columnar structures **416** out of open ends **418** of coil engaging features **414**. With coil engaging features **414** removed, coil **402** collapses down into a small form factor for storage, shipping, etc.

FIG. 5 shows a perspective view of a collapsible plant support structure **500** according to another embodiment of the present invention. Plant support structure **500** includes a collapsible coil **502**, a plurality of vertical structures **504**, and a plurality of vertical support structures **506**. Collapsible coil **502** is substantially similar to coils **302** and **402** in that it is naturally in a collapsed state when not being held open by vertical support structures **506**. Coil **502** includes a bottom region **508** and an opposite top region **510**. Bottom region **508** is defined by a portion of coil **502** that is wound in a plane such that bottom region **508** is adapted to rest on a flat surface. In this example, vertical structures **504** limit horizontal movement of plant branches extending out of collapsible plant support structure **500**, as in the embodiments described above.

Each of vertical support structures **506** includes two coil engaging features **514** and a columnar structure **516** disposed therebetween. In this example, coil engaging features **514** are solid wire protrusions attached to coil **502** by some suitable means such as, for example, a tack weld. Each of coil engaging features **514** is adapted to be inserted into a respective open end **518** of a respective one of columnar structures **516**. Each of columnar structures **516** is a rigid tube formed from some suitable material such as, for example, plastic, metal, fiberglass, etc. The rigidity and strength of columnar structures **516** is such that they do not buckle under the spring force of coil **502** and the weight of a plant growing out of collapsible plant support structure **500**. In addition to providing vertical support, columnar structures **516** also provide horizontal support to plants growing from plant support structure **500**. Collapsible plant support structure **500** can be stored simply by sliding coil engaging features **514** out of open ends **518** of columnar structures **516**. With coil engaging features **514** removed, coil **502** collapses down into a small form factor for storage, shipping, etc.

FIG. 6 shows a perspective view of a collapsible plant support structure **600** according to another embodiment of the present invention. Plant support structure **600** provides additional support to plants as well as preventing water and/or soil from falling onto the underlying floor. In addition,

plant support structure **600** derives additional stability from the weight of a potted plant (not shown) placed with plant support structure **600**. Plant support structure **600** includes a collapsible coil **602**, a plurality of vertical structures **604**, a plurality of vertical support structures **606**, and a plant receptacle receiving element **608**.

Collapsible coil **602** is substantially similar to coils **302**, **402**, and **502** in that it is naturally in a collapsed state when not being held open by vertical support structures **606**. Coil **602** includes a bottom region **610** and an opposite top region **612**. Bottom region **610** is defined by a portion of coil **602** that is wound in a plane such that bottom region **610** is adapted to rest on a flat surface. Optionally, the bottom region **610** of coil **602** can be rigidly fastened to plant receptacle receiving element **608**. Vertical structures **604** limit horizontal movement of plant branches extending out of collapsible plant support structure **600**.

Each of vertical support structures **606** includes a first coil engaging feature **616**, columnar structure engaging feature **618**, and a columnar structure **620** disposed therebetween. In this example, each of first coil engaging features **616** is a tubular rigid female couplings attached to top region **612** of coil **602**. Each of first coil engaging features **616** includes an open end **622** adapted to receive a respective bottom end of a respective one of columnar structures **620**. Each of columnar structure engaging feature **618** is a tubular rigid female couplings attached to plant receptacle receiving element **608** (stabilizing base). Each of columnar structure engaging features **618** include an open end **624** adapted to receive a respective bottom end of a respective one of columnar structures **620**. Each of columnar structures **620** is a rigid pole or tube formed from some suitable material such as, for example, plastic, wood, fiberglass, etc. The rigidity and strength of columnar structures **620** is such that they do not buckle under the spring force of coil **602** and the weight of a plant growing out of collapsible plant support structure **600**. In addition to providing vertical support, columnar structures **620** also provide horizontal support to plants growing from plant support structure **600**.

Plant receptacle receiving element **608** is, for example, a rigid pan having bottom wall **626** and a cylindrical sidewall **628** extending upward therefrom. As shown, columnar structure engaging features **618** are rigidly attached to the inside of cylindrical sidewall **628**. Plant receptacle receiving element **608** provides several advantages including preventing soil and/or water from falling onto the underlying floor. As another example advantage, plant receptacle receiving element **608** prevents coil **602** from tipping because the weight of the bucket rests on bottom wall **626**, thereby providing a stabilizing base for collapsible plant support structure **600**.

Although not shown, the vertical height of cylindrical sidewall **628** can be tall enough that coil **602** can be collapsed completely inside of plant receptacle receiving element **608**. This is beneficial in that several collapsible plant support structures **600** can be stacked efficiently when packaged or just when being stored and/or shipped. In other words, when in the collapsed position, collapsible plant support structure **600** would have the same form factor as plant receptacle receiving element **608**. Furthermore, columnar structures **620** can be collapsible so that each of columnar structures **620** could also be stored in plant receptacle receiving element **608** during storage and/or shipping of collapsible plant support structure **600**.

FIG. 7 shows a perspective view of collapsible plant support structure **300** (FIG. 3) in combination with a stabilizing base. In particular, plant support structure **300** is fixed to a plant receptacle receiving element **700**. In this example,

plant receptacle receiving element **700** is a flat plate that is coupled to bottom region **308** of coil **302** via a set of fasteners **702** (e.g., zip-tie, metal wire, etc.). Optionally, element **700** can be directly fixed to bottom region **308** of coil **302** by, for example, welding or an adhesive. During use, a plant receptacle (i.e. bucket) rests on plant receptacle receiving element **700**, which provides stability to plant support structure **300**. Indeed, plant support structure **300** is much more difficult to tip under the weight of a plant when the weight of the plant receptacle is resting on plant receptacle receiving element **700**. Plant receptacle receiving element **700** can be constructed out of any suitable material including, but not limited to, wood, plastic, and/or metal, that is capable of transferring weight from a potted plant to the bottom region **308** of coil **302**.

FIG. **8** shows a side view of a collapsible plant support structure **800** according to another embodiment of the present invention. Plant support structure **800** includes a collapsible coil **802**, a plurality of vertical structures **804**, and a plurality of vertical support structures **806**. Collapsible coil **802** is substantially similar to coils **302**, **402**, **502**, and **602** in that it is naturally in a collapsed state when not being held open by vertical support structures **806**. Coil **802** includes a bottom region **808** and an opposite top region **810**. Bottom region **808** is defined by a portion of coil **802** that is wound in a plane. Vertical structures **804** are formed from individual pieces of string that are each tied into knots **812** attached to both bottom region **808** and top region **810**. Each of vertical support structures **806** includes two coil engaging features **814** and a columnar structure **816** disposed therebetween. In this example, coil engaging features **814** are outward facing hooks that engage both bottom region **808** and top region **810** of coil **802**. Each of columnar structures **816** is a rigid column structure formed from some suitable material such as, for example, plastic, metal, fiberglass, wood, etc. Collapsible plant support structure **800** can be broken down for storage simply by disengaging bottom region **808** and top region **810** from coil engaging features **814**. With coil engaging features **814** disengaged, coil **802** collapses down into a small form factor for storage, shipping, etc.

FIG. **9** shows a side view of a collapsible plant support structure **900** according to another embodiment of the present invention. Plant support structure **900** includes a collapsible coil **902**, a plurality of vertical structures **904**, and a plurality of vertical support structures **906**. Collapsible coil **902** is substantially similar to coil **200** in that it is naturally in an open position when not engaged by vertical support structures **906**. Coil **902** includes a bottom region **908** and an opposite top region **910**. Bottom region **908** is defined by a portion of coil **902** that is wound in a plane. Vertical structures **904** are formed from individual pieces of string that are each tied into knots **912** attached to both bottom region **908** and top region **910**. Each of vertical support structures **906** includes two coil engaging features **914** and a columnar structure **916** disposed therebetween. In this example, coil engaging features **914** are inward facing hooks that engage both bottom region **908** and top region **910** of coil **902**. Each of columnar structures **916** is a rigid column structure. Collapsible plant support structure **900** can be broken down for storage simply by disengaging bottom region **908** and top region **910** from coil engaging features **914**, compressing coil **902**, and then fastening coil **902** in a compressed position by some suitable means such as hook-and-loop fasteners.

FIG. **10** shows a side view of a collapsible plant support structure **1000** according to another embodiment of the

present invention. Plant support structure **1000** includes a collapsible coil **1002**, a plurality of vertical structures **1004**, and a plurality of vertical support structures **1006**. Collapsible coil **1002** includes a bottom region **1008** and an opposite top region **1010**. Bottom region **1008** is defined by a portion of coil **1002** that is wound in a plane. Vertical structures **1004** are formed from individual pieces of string that are each tied into knots **1012** attached to both bottom region **1008** and top region **1010**. Each of vertical support structures **1006** is removably coupled to coil **1002** and restrains coil **1002** in a deployed position.

FIG. **11** shows a perspective view of a portion of one of vertical support structures **1006** removed from coil **1002**. As shown, each of vertical support structures **1006** is a columnar structure having a plurality of coil engaging features **1100** formed therein. Coil engaging features **1100** are notches contoured to engage coil **1002** at multiple locations, including the top, bottom, and intermediate turns of coil **1002**. When coil **1002** is engaged within coil engaging features **1100**, coil **1002** is not free to move in the vertical direction. Therefore, the natural state of coil **1002** (either compressed or open) is irrelevant to the design of plant support structure **1000**. Indeed, coil **1002** can be of either a naturally compressed or naturally decompressed type.

FIG. **12** shows a perspective view of a collapsible plant support structure **1200** according to another embodiment of the present invention. Plant support structure **1200** includes a collapsible coil **1202**, a plurality of vertical structures **1204**, and a plurality of vertical support structures **1206**. Collapsible coil **1202** is substantially similar to coils **302**, **402**, **502**, **602**, and **802** in that it is naturally in a collapsed position when not engaged by vertical support structures **1206**. Coil **1202** includes a bottom region **1208** and an opposite top region **1210**. Bottom region **1208** is defined by a portion of coil **1202** that is wound in a plane.

Vertical structures **1204** are formed from individual pieces of string that are each tied into knots **1212** attached to both bottom region **1208** and top region **1210**.

Each of vertical support structures **1206** includes two coil engaging features **1214**, a columnar structure **1216**, and a plurality of annular elements **1218**. In this example, coil engaging features **1214** are cylindrical end caps attached to bottom region **1208** and top region **1210** of coil **1202** by some suitable means (e.g. spot weld). Each of coil engaging features **1214** is adapted to receive a respective end of a respective one of columnar structures **1216**. Each of columnar structures **1216** is a rigid column structure held in place by the natural tendency of coil **1202** to compress. Each annular element **1218** is adapted to slidably engage the exterior surface of columnar structures **1216**. Furthermore, each of annular elements is a metal ring attached to coil **1202** by some suitable means such as, for example, a tack weld. Annular elements **1218** increase the number of inflection points of columnar structures **1216** thereby substantially increasing the force columnar structure **1216** is capable of supporting before buckling. Collapsible plant support structure **1200** can be broken down for storage simply by removing columnar structures **1216** from coil engaging features **1214** and sliding them out of annular elements **1218**. With columnar structures **1216** removed, coil **1202** is able to compress thereby having a substantially smaller form factor.

FIG. **13** shows a perspective view of collapsible plant support structure **410** (FIG. **4**) in combination with another feature of the present invention. In this example, plant support structure **410** additionally includes a grid structure **1300** coupled to top region **410** of coil **402**. Grid structure

11

1300 is a removable structure that can be optionally used to provide additional support to both plant support structure **410** and plants growing therefrom. Grid structure **1300** can be formed a variety of different ways. For example, grid structure **1300** can be a wire mesh structure or a grid of elastic cords.

FIG. **14** shows a perspective view of a collapsible plant support structure **1400** according to another embodiment of the present invention. Plant support structure **1400** includes a collapsible coil **1402**, a plurality of vertical structures **1404**, a plurality of vertical support structures **1406**, and a plant receptacle receiving element **1408**.

Collapsible coil **1402** is substantially similar to coils **302**, **402**, **502**, **602**, **802**, and **1202** in that it is naturally in a collapsed state when not being held open by vertical support structures **1406**. Coil **1402** includes a bottom region **1410** and an opposite top region **1412**. Bottom region **1410** is defined by a portion of coil **1402** that is wound in a plane such that bottom region **1410** is adapted to rest on a flat surface.

In this example, vertical structures **1404** are formed from individual pieces of string that are each tied into knots **1414** attached to both bottom region **1410** and top region **1412**.

Each of vertical support structures **1406** includes a first coil engaging feature **1416**, a second coil engaging feature **1418**, and a columnar structure **1420** disposed therebetween. In this example, each of first coil engaging features **1416** is a tubular rigid female couplings attached to top region **1412** of coil **1402**. Each of first coil engaging features **1416** includes an open end **1422** adapted to receive a respective top end of a respective one of columnar structures **1420**. Each of second coil engaging features **1418** is a tubular rigid female couplings attached to bottom region **1410** of coil **1402**. Each of second coil engaging features **1418** includes an open end **1424** that is adapted to receive a respective bottom end of a respective one of columnar structures **1420**. Each of second coil engaging features **1418** is also adapted to fit into a respective set of cylindrical apertures **1426** formed in plant receptacle receiving element **1408**.

Plant receptacle receiving element (stabilizing base) **1408** is, for example, a molded plastic structure that includes a flat surface **1428**, an annular channel **1430**, a sidewall **1432**, a pitched surface **1434**, a drain duct **1436**, and a watering duct network **1438**. Flat surface **1428** is adapted to support a plant receiving receptacle such as, for example, a bucket. Annular channel **1430** is adapted to seat bottom region **1410** of coil **1402** therein. Sidewall **1432** extends upward and defines apertures **1426**. Pitched surface **1434** enables water that falls onto plant receptacle receiving element **1408** to move to drain duct **1436**. Drain duct **1436** includes an inlet **1440** and an outlet **1442** formed on pitched surface **1434** and sidewall **1432**, respectively. Watering duct network **1438** enables multiple plant receptacle receiving elements **1408** to be connected to a single water source or any desirable fluid network.

FIG. **15** shows a cross-sectional side view of plant receptacle receiving element **1408**. As shown, apertures **1426** extend only partially into plant receptacle receiving element **1408** so as to support vertical support structures **1406** in an upright position. Watering duct network **1438** is formed from two perpendicular ducts passing entirely through plant receptacle receiving element **1408**.

FIG. **16** shows a cross-sectional side view of plant receptacle receiving element **1600** according to an alternate embodiment of the present invention. The features of plant receptacle receiving element **1600** are substantially similar to plant receptacle receiving element **1408**. Therefore, fea-

12

tures of plant receptacle receiving element **1600** that are substantially identical to those of plant receptacle receiving element **1408** will be referenced with like numbers. The only difference between plant receiving element **1600** and **1408** is that receptacle receiving element **1600** includes a sidewall **1602** that is much taller than sidewall **1432**. The height of sidewall **1602** is such that a coil **1604** can fit entirely within the form factor of plant receptacle receiving element **1600** when collapsed. This is particularly desirable in that it facilitates convenient storage and/or stackability of a collapsible plant support structure.

FIG. **17** shows a perspective view of a columnar support structure **1700** that is capable supporting coil **1604**. Columnar support structure **1700** can be collapsed down to fit within the form factor of plant receptacle receiving element **1600**. As shown, columnar support structure **1700** includes three discrete tubular sections **1702** friction fit together via tubular couplings **1704**. Columnar support structure **1700** further includes an elastic cord **1706** disposed in sections **1702** so as to prevent sections **1702** from being disconnected. Columnar support structure **1700** can also be substituted for the column support structures of previously described embodiments.

FIG. **18** shows a top view of an array **1800** of plant receptacle receiving elements **1408**_{1,1} through **1408**_{3,3} connected to form a fluid network. As shown, each watering duct network **1438** of respective plant receptacle receiving elements **1408** includes a top port **1802**, a left port **1804**, a right port **1806**, and a bottom port **1808**.

In this example, water is supplied to array **1800** through a single water source **1810** coupled to top port **1802** of plant receptacle receiving element **1408**_{1,1}. Left port **1804** of plant receptacle receiving elements **1408**_{1,1} is closed via a plug **1812**. Right port **1804** of plant receptacle receiving element **1408**_{1,1} is coupled to a T-coupling **1814** so as to supply water to both a watering outlet **1816** of plant receptacle receiving element **1408**_{1,1} and also to left port **1804** of plant receptacle receiving element **1408**_{2,1}. Bottom port **1808** supplies water directly to top port **1802** of plant receptacle receiving element **1408**_{1,2}.

Top port **1802** of plant receptacle receiving element **1408**_{1,2} receives water supplied by bottom port **1808** of plant receptacle receiving element **1408**_{1,1}. Left port **1804** of plant receptacle receiving elements **1408**_{1,2} is closed via a plug **1812**. Right port **1804** of plant receptacle receiving element **1408**_{1,2} is coupled to a T-coupling **1814** so as to supply water to both a watering outlet **1816** of plant receptacle receiving element **1408**_{1,2} and also to left port **1804** of plant receptacle receiving element **1408**_{2,2}. Bottom port **1808** of plant receptacle receiving element **1408**_{1,2} is closed via a plug **1812**. However, bottom port **1808** of plant receptacle receiving element **1408**_{1,2} could also be coupled to supply water to another plant receptacle receiving element **1408**.

Top port **1802** of plant receptacle receiving element **1408**_{2,1} is closed via a plug **1812**. Left port **1804** of plant receptacle receiving elements **1408**_{2,1} receives water supplied by right port **1806** of plant receiving element **1408**_{1,1} through T-coupling **1814**. Right port **1804** of plant receptacle receiving element **1408**_{2,1} supplies water to a watering outlet **1816** of plant receptacle receiving element **1408**_{2,1}. Optionally, right port **1804** could be coupled to a T-coupling so as to supply water to yet another plant receptacle receiving element **1408**. Bottom port **1808** of plant receptacle receiving element **1408**_{2,1} is coupled directly to top port **1802** of plant receptacle receiving element **1408**_{2,2}.

Top port **1802** of plant receptacle receiving element **1408**_{2,2} receives water supplied by bottom port **1808** of plant

receptacle receiving element **1408**_{2,1}. Left port **1804** of plant receptacle receiving elements **1408**_{2,2} receives water supplied by right port **1806** of plant receptacle receiving element **1408**_{1,2} indirectly through a T-coupling **1814**. Right port **1804** of plant receptacle receiving element **1408**_{2,2} supplies water to a watering outlet **1816** of plant receptacle receiving element **1408**_{2,2}. Optionally, right port **1804** of plant receptacle receiving element **1408**_{2,2} could be coupled to a T-coupling so as to supply water to yet another plant receptacle receiving element **1408**. Bottom port **1808** of plant receptacle receiving element **1408**_{2,2} is closed via a plug **1812**. However, bottom port **1808** of plant receptacle receiving element **1408**_{2,2} could also be coupled to supply water to another plant receptacle receiving element **1408**. Indeed, number and layout of plant receptacle receiving elements **1408** can be arranged according to user preference and water supply parameters (i.g., pressure, flow rate, etc.).

The manufacturing of a collapsible plant support structure **1900** is described as follows with reference to FIGS. **19A**, **19B**, and **19C**.

In a first step illustrated in FIG. **19A**, an insert mold **1902** is provided. Insert mold **1902** includes a center **1904** and two sides **1906**. Mold center **1904** includes an exterior surface **1908** defining a helical channel **1910**, a set of vertical channels **1912**, and a set ring cavities **1914**. Similarly, mold sides **1906** include interior surfaces **1916** each defining a complimentary helical channel **1918**, a complimentary set of vertical channels **1920**, and a complimentary set of ring cavities **1922**.

In a second step, a metal coil **1924** (shown in FIG. **20**) is placed into mold **1902** as an insert. That is, coil **1924** is seated in helical channel **1910** of mold center **1904**.

In a third step, depicted in FIG. **19B**, mold **1902** is closed with coil **1924** seated in helical channel **1910**. When mold **1902** is closed, helical channel **1910** and complimentary helical channel **1918** form a helical cavity that has an inner diameter slightly larger than the outer diameter of coil **1924**. When resin is injected into the helical cavity formed by helical channel **1910** and complimentary helical channel **1918**, a resin shell **1926** (shown in FIG. **19C** and FIG. **20**) is formed around coil **1924**. Furthermore, when mold **1902** is closed, vertical channels **1912** and **1920** align to form four vertical bores that intersect the helical cavity formed by helical channels **1912** and **1918**. When resin (e.g., rubber, plastic, etc.) is injected into the vertical bores formed by vertical channels **1912** and **1920**, vertical structures **1928** (shown in FIG. **19C**) attached to shell **1926** are formed. When mold **1902** is closed, ring cavities **1914** and complimentary ring cavities **1922** also align to form a ring shaped cavity. When resin is injected into the ring shaped cavities, a plurality of ring features **1930** (shown in FIG. **19C** and FIG. **20**) are integrally formed on resin shell **1926**.

Once the injected resin is sufficiently cooled, mold **1902** is opened and collapsible plant support **1900** (shown in FIG. **19C**) is removed from mold center **1904**. Collapsible plant support **1900** includes resin coated metal coil **1924**, a plurality vertical structures **1928** composed of resin, and a plurality of ring features **1930** composed of resin.

The functionality of collapsible plant support structure **1900** is substantially similar to that of collapsible plant support structure **1200**. Therefore, redundant descriptions of plant support structure **1900** and like components are not provided for the sake of brevity. Although not shown, collapsible plant support structure **1900** also includes four vertical support structures **1216** to hold collapsible plant support structure **1900** in an open position. Depending on

the type of support structures used, additional coil engaging features (not shown) can be provided by mold **1902**.

Although not shown, fold lines or features can be molded into vertical structures **1928** (e.g., halfway between each turn of coil **1924**). The fold lines effectively cause each intermediate region of vertical structures **1928** between each turn of coil **1924** to collapse inward when coil **1924** is collapsed downward.

FIG. **20** shows a perspective view of a section **2000** of collapsible plant support structure **1900**. As shown, section **2000** include a section of metal coil **1924** having a resin shell **1926** and a resin ring feature **1930** formed thereon. Resin ring feature **1930** is adapted to slidably engage the exterior surface of a vertical support structure **1216** or the like.

FIG. **21** shows a side view of a collapsible plant support structure **2100** according to another embodiment of the present invention. Plant support structure **2100** includes a plurality of discrete rigid rings **2102**, a plurality of vertical structures **1204**, and a plurality of vertical support structures **1206**. The bottom one of rings **2102** defines a bottom region **2108** and an opposite top one of rings **2102** defines a top region **2110** of collapsible plant support structure **2100**. Vertical structures **2104** are formed from individual pieces of cord that are each tied into knots **2112** attached to each of rings **2102**. Alternatively, vertical structures **2104** can be formed from individual pieces of elastic cord tied to each of rings **2102**. Each of vertical support structures **2106** includes two ring engaging features **2114** and a columnar structure **2116** disposed therebetween. In this example, ring engaging features **2114** are outward facing hooks that engage both the bottom and top ones of rings **2102**. Each of columnar structures **2116** is a rigid column structure formed from some suitable material such as, for example, plastic, metal, fiberglass, wood, etc. Collapsible plant support structure **2100** can be broken down for storage simply by disengaging rings **2102** from ring engaging features **2114**. With ring engaging features **2114** disengaged, rings **1202** collapse down into a small form factor for storage, shipping, etc.

FIG. **22** and FIG. **23** show a perspective view and a side view, respectively, of another example collapsible plant support structure **2200** in an open (deployed) state. In this particular embodiment, collapsible plant support structure **2200** includes a collapsible coil **2202** and a flexible mesh (e.g., net, web, lattice, etc.) **2204** coupled thereto. Collapsible coil **2202** has a resistance to compression sufficient to support plants without collapsing, yet is capable of being compressed by a user when not in use.

Coil **2202** includes a bottom portion **2206** and an opposite top portion **2208**. Bottom portion **2206** is defined by an end of coil **2202** that is wound in a plane and fastened such that bottom portion **2206** is adapted to rest on a flat surface (e.g., ground, floor, deck, etc.). Similarly, top portion **2208** is defined by an opposite end of coil **2202** that is wound in a plane and fastened to form a substantially planar top of plant support structure **2200**.

Flexible mesh **2204** provides both horizontal and vertical support to plants when coil **2202** is deployed. In the example embodiment, mesh **2204** is formed from a thin, strong, flexible plastic film that is stitched to the interior of coil **2202**. However, those skilled in the art will recognize that mesh **2204** can be formed from many suitable materials including, but not limited to, natural or synthetic fabric, nylon, reinforced polymers, and so on. Mesh **2204** can also be fastened to either the interior or exterior of coil **2202** by any suitable fastening means. Mesh **2204** also serves as a retainer, because it prevents coil **2202** from expanding beyond its intended deployed length. Mesh **2204** also pro-

vides horizontal and torsional support to coil **2202** in its deployed state and prevents coil **2202** from expanding beyond its intended diameter. In other words, mesh **2204** restrains coil **2202** in its intended shape in its deployed state.

Collapsible plant support structure **2200** further includes a set of retaining features **2210** which, in this example, includes a set of toggle buttons **2212** and complementary loops **2214** for retaining structure **2200** in a collapsed state when not in use. Alternatively, toggle buttons **2212** and complementary loops **2214** can be replaced with any other suitable retaining feature including, but not limited to, hook-and-loop fasteners, ties, an external case, and so on.

FIG. **24** shows a perspective view of a section of coil **2202** and a section of mesh **2204** according to one example embodiment. Coil **2202** includes a wire **2400** disposed within a sleeve **2402**. Wire **2400** is essentially a spring steel wire coil having moderate resistance to compression such that it can be easily compressed to a very small size during shipping and/or storage, but is sufficient to support plants without collapsing when deployed. Indeed, coil **2202** exerts a sufficient expansive force to support plants without the need for any additional support members. Sleeve **2402** provides a means for securing mesh **2204** to wire **2400** and is formed from flexible fabric **2404** that is fastened together via stitching **2406**. Mesh **2204** is also fastened directly to sleeve **2402** via stitching **2408**.

In the example embodiment, wire **2400** has a natural tendency to straighten out but is held in a helical position by sleeve **2402** and mesh **2204**. The natural tendency of wire **2400** to straighten out provides force sufficient to deploy mesh **2204** in an open cylindrical configuration. Although wire **2400** is somewhat of a straight wire that is held in a loaded helical position, it could be substituted with a coil that naturally takes the form of a helix without having to be retained by mesh **2204** and/or sleeve **2402**. In such a case, the purpose of sleeve **2402** would be to fasten mesh **2204** to the already helical wire. In another alternate embodiment, mesh **2204** can be fixed directly to wire **2400** by some suitable means (e.g., adhesive, through-holes formed in mesh **2204**, etc.) thus eliminating the need for sleeve **2402**.

FIG. **25** shows a side view of collapsible plant support structure **2200** in a compressed, closed state. As shown, structure **2200** is held in the compressed state by first urging bottom region **2206** and top region **2208** toward one another. Once compressed, coil **2202** is held in place while each of toggle buttons **2212** is inserted into a respective one of complementary loops **2214**. When locked in the compressed position, structure **2200** occupies minimal volume and is, therefore, convenient to store and transport. Plant support structure **2200** automatically deploys when toggle buttons **2212** are disengaged from complementary loops **2214**.

The description of particular embodiments of the present invention is now complete. Many of the described features may be substituted, altered or omitted without departing from the scope of the invention. For example, alternate fluid network layouts (e.g., larger arrays of plant receptacle receiving elements), may be substituted for the 2x2 array **1800**. As another example, the various described coils can have various different characteristics such as number of helical turns, shapes, spring force coefficient, etc. As yet another example, most embodiments are shown with 4 vertical support structures and 4 vertical structures. However, a greater or lesser number of vertical support structures and/or vertical structures can be used. These and other deviations from the particular embodiments shown will be apparent to those skilled in the art, particularly in view of the foregoing disclosure.

I claim:

1. A collapsible plant support structure comprising:
 - a coil having an axis, a bottom end and a top end, said bottom end being configured to rest on a planar surface, said coil being collapsible along said axis; and
 - a flexible material coupled to said coil and defining a plurality of openings to facilitate the passage of significant parts of a plant therethrough, said flexible material configured in a generally cylindrical shape and being coupled to said coil at a plurality of locations to limit the expansion of said coil and the movement of said material with respect to said coil; and wherein said coil is self-supporting in an expanded state when said bottom end of said coil is resting on said planar surface; said coil has sufficient resistance to compression to provide support for said significant parts of said plant passing through said plurality of openings without fully collapsing said coil; and said collapsible plant support structure has an open bottom.
2. The collapsible plant support structure of claim 1, wherein said coil includes a substantially straight wire that is secured in a helical position at least in part by said flexible material.
3. The collapsible plant support structure of claim 2, further comprising a flexible sleeve, and wherein:
 - at least a portion of said coil is disposed in said flexible sleeve; and
 - said flexible material is fastened to said flexible sleeve.
4. The collapsible plant support structure of claim 2, further comprising a flexible sleeve, and wherein:
 - at least a portion of said coil is disposed in said flexible sleeve; and
 - said flexible sleeved is fastened to said flexible material in a helical configuration around said generally cylindrical shape of said flexible material.
5. The collapsible plant support structure of claim 3, wherein said flexible material is in a mesh configuration.
6. The collapsible plant support structure of claim 5, wherein said plurality of openings includes a uniform array of rectangular openings, said openings being wider and taller than a portion of said material between said openings.
7. The collapsible plant support structure of claim 3, wherein said openings are wider and taller than portions of said flexible material between adjacent ones of said openings.
8. The collapsible plant support structure of claim 3, wherein said plurality of openings occupies a majority of a surface of said flexible material configured in said generally cylindrical shape.
9. The collapsible plant support structure of claim 1, wherein said coil includes a wire having a natural helical shape.
10. The collapsible plant support structure of claim 9, wherein said flexible material is connected directly to said wire.
11. The collapsible plant support structure of claim 1, further comprising a retaining feature operative to retain said coil in a compressed position when said collapsible plant support structure is not in use.
12. The collapsible plant support structure of claim 11, wherein said retaining feature includes a toggle button and loop fastener.
13. The collapsible plant support structure of claim 1, wherein said coil is formed from spring steel.

14. The collapsible plant support structure of claim 1, wherein said plurality of openings includes a uniform array of rectangular openings.

15. The collapsible plant support structure of claim 1, wherein:

said flexible material includes a plurality of horizontal sections and a plurality of vertical sections of said material;

said plurality of horizontal sections intersect said plurality of vertical sections to define said plurality of openings; and

said plurality of horizontal sections are fixed to said plurality of vertical sections where said horizontal sections intersect said vertical sections.

16. The collapsible plant support structure of claim 1, wherein said openings have a size sufficient to allow enough of a portion of a plant to pass therethrough to provide support to said plant by said flexible material.

17. The collapsible plant support structure of claim 1, wherein said openings define an area greater than an area of said flexible material between said openings.

18. The collapsible plant support structure of claim 1, wherein said openings have a width greater than a width of said flexible material between adjacent ones of said openings.

* * * * *