

(19) World Intellectual Property Organization  
International Bureau



(43) International Publication Date  
8 January 2009 (08.01.2009)

PCT

(10) International Publication Number  
**WO 2009/003473 A1**

(51) International Patent Classification:  
**G01W 1/14** (2006.01)

(21) International Application Number:

PCT/DK2008/000236

(22) International Filing Date: 25 June 2008 (25.06.2008)

(25) Filing Language: English

(26) Publication Language: English

(30) Priority Data:

PA 2007 00948 29 June 2007 (29.06.2007) DK

(71) Applicant (for all designated States except US): **VKR HOLDINGS A/S** [DK/DK]; Breettevej 18, DK-2970 Hørsholm (DK).

(72) Inventors; and

(75) Inventors/Applicants (for US only): **JENSEN, Torben, Højriis** [DK/DK]; Engvangen 33, DK-7200 Grindsted (DK). **OLESEN, Thomas, Vilsmark** [DK/DK]; Gl. Kongevej 38, DK-6880 Tarm (DK).

(81) Designated States (unless otherwise indicated, for every kind of national protection available): AE, AG, AL, AM, AO, AT, AU, AZ, BA, BB, BG, BH, BR, BW, BY, BZ, CA, CH, CN, CO, CR, CU, CZ, DE, DK, DM, DO, DZ, EC, EE, EG, ES, FI, GB, GD, GE, GH, GM, GT, HN, HR, HU, ID, IL, IN, IS, JP, KE, KG, KM, KN, KP, KR, KZ, LA, LC, LK, LR, LS, LT, LU, LY, MA, MD, ME, MG, MK, MN, MW, MX, MY, MZ, NA, NG, NI, NO, NZ, OM, PG, PH, PL, PT, RO, RS, RU, SC, SD, SE, SG, SK, SL, SM, SV, SY, TJ, TM, TN, TR, TT, TZ, UA, UG, US, UZ, VC, VN, ZA, ZM, ZW.

(84) Designated States (unless otherwise indicated, for every kind of regional protection available): ARIPO (BW, GH, GM, KE, LS, MW, MZ, NA, SD, SL, SZ, TZ, UG, ZM, ZW), Eurasian (AM, AZ, BY, KG, KZ, MD, RU, TJ, TM), European (AT, BE, BG, CH, CY, CZ, DE, DK, EE, ES, FI, FR, GB, GR, HR, HU, IE, IS, IT, LT, LU, LV, MC, MT, NL, NO, PL, PT, RO, SE, SI, SK, TR), OAPI (BF, BJ, CF, CG, CI, CM, GA, GN, GQ, GW, ML, MR, NE, SN, TD, TG).

Published:

— with international search report

(54) Title: **PIEZOELECTRIC PRECIPITATION SENSOR**

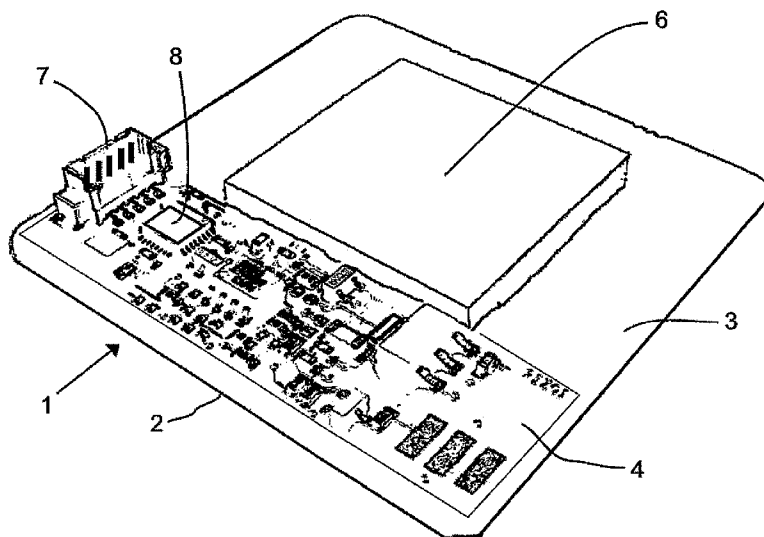

Fig. 1

(57) Abstract: A precipitation sensor comprising an impact membrane provided with a transducer for detecting impact of precipitation on the impact membrane, a circuit board comprising electric circuit components adapted to receive an electric input signal from said transducer and to produce an output signal, where said electric circuit components and said transducer are mounted on a first side of the circuit board and that a second side of the circuit board comprises said impact membrane. The circuit board and impact membrane are preferably one and the same element and transducer is preferably a piezoelectric element soldered to the first side of the circuit board.

WO 2009/003473 A1

## Piezoelectric precipitation sensor

The present invention relates to a precipitation sensor comprising an impact membrane provided with a transducer for detecting impact of precipitation on the impact membrane, a circuit board comprising electric circuit components adapted to receive an electric input signal from said transducer and to produce an output signal.

Rain sensors are among other things used for controlling windows such as roof windows in order to detect a rainfall and subsequently close open windows during a rainfall. This is a big advantage for controlling windows in buildings comprising several windows or in case a window unintentionally is left open during a rainfall, which constitutes a possible risk of rain penetrating through the open window.

It is well known to design simple rain sensors having a printed circuit board with comb-toothed prints. One example of a rain sensor of this type is disclosed in JP 9061393. When rain falls on the comb-toothed prints, a change in either the resistance or capacitance of the comb-toothed prints can be utilized to detect rainfall. Especially, a rain sensor, which also detects a capacitive change as the print dries after a rainfall, is commonly used for controlling windows. A rain sensor of this type has a significant drawback by having high power consumption, which is a problem when it is used in connection with for instance windows powered by solar cells. Furthermore, a rain sensor of this type will not react instantly on certain precipitation types such as hail and eventually only if the hail results in a resistive or capacitive change, depending of the design principle used in the sensor.

A precipitation sensor according to the opening paragraph is known from WO 03/027720, which discloses a detector for measuring precipitation parameters. The detector comprises a substantially rigid surface adapted to receive impinging hydrometeors and detection means such as a piezoelectric element connected to said surface for converting impact impulses from said hydrometeors into an electric signal, which by means of electric circuitry located inside the housing of the detector is amplified and processed for calculating precipitation pa-

rameters.

From DE 103 30 128 is known another precipitation sensor according to the opening paragraph for detecting the size of hails impacting on a baffle plate. A piezoelectric element is glued to the back side of the baffle plate and thereby produces an electric signal dependent on the size of hails impacting the baffle plate. The baffle plate is mounted as a lid on a box comprising side wall and a bottom plate placed opposite the baffle plate. The fact that the electric output signal of a second piezoelectric sensor provided on the bottom plate is independent on the size of hails impacting on the baffle plate, is utilized for determining the size of hails impacting on the baffle plate by comparing the output signals from the two piezoelectric elements.

GB 2 412 735 discloses an acoustic rain sensor having a microphone housed in a waterproof housing which also contains a printed circuit board. The microphone senses the impact of raindrops on the surface of the housing, and thereby the intensity of the rainfall can be determined.

From JP 2195250 is it know to use piezoelectric elements for sensing raindrops on a window by attaching two piezoelectric devices adjacent on the inside of a window pane. One of the devices transmits ultrasonic waves and the other receives the ultrasonic waves reflected on the outer surface of the window pane. Rainfall can be detected because the reflected wave fluctuates due to raindrops on the outside of the window pane. However, for many applications like automatized windows for buildings, it is not desirable to have piezoelectric devices mounted on a window pane. Besides from an aesthetical point of view, it is problematic that a sensor mounted on the window pane for instance through a wire has to transmit a signal to a window controlling device which typically is located elsewhere in the window construction.

It is the object of the present invention to provide a precipitation sensor of the above-mentioned type, which has a low power consumption and a simple design.

To meet this object the invention provides a precipitation sensor of the above-mentioned type characterized in that said electric cir-

cuit components and said transducer are mounted on a first side of the circuit board and that a second side of the circuit board comprises said impact membrane. When the circuit board is provided with a transducer having a very low power consumption or without the need of a power supply to produce an electric output signal on basis of precipitation impinging the membrane, a precipitation sensor having a low power consumption for sensing precipitation in general is achieved. The circuit board and impact membrane can be one and the same element, which provides a very simple design with a reduced material consumption and in addition to the reduced material consumption the sensor is correspondingly easier and cheaper to produce. Furthermore, the properties of the sensor are not affected by filth and dirt, which can accumulate on the impact membrane of a sensor disposed outdoors.

In a further developed embodiment of the invention, the surface of said second side of the circuit board is embossed to provide an uneven surface, which enhances the amount of energy transferred to the membrane by impacting precipitation.

In another embodiment of the invention, said circuit board comprises means for rolling up a connection wire. Thereby the sensor can easily be adapted to be used in conjunction with different types of installations or for instance at different distances from a window or a window controlling device controlling the operation of a window.

In yet another development of the invention said transducer is a piezoelectric element, which in a preferred embodiment is mounted to said first side of the circuit board by soldering. Thereby connection wires between the piezoelectric element and the electronic circuit board are rendered superfluous and furthermore the precipitation sensor can be produced by using soldering techniques known per se such as reflow soldering. This makes the production of the sensor faster and easier and the sensor is thereby assembled in one piece by using existing production techniques.

In another development of the invention, said second side of the circuit board comprises at least two adjacent circuit prints in order to achieve a precipitation sensor comprising the properties of conven-

tional resistive or capacitive rain sensor as described above, which also can detect mist and dew.

Furthermore, said circuit board can be adapted to form a cover of an opening in a housing, which makes it possible to use the sensor in combination with a housing used for conventional housings. By designing the sensor to be a removable element adapted to fit in a housing it can also easily be replaced in case of a malfunction or it can replace existing sensors not having the properties of the disclosed invention. In general the design provides a sensor having a flush or planar surface, which gives a more pleasant appearance when it is built into for instance a window. This is further facilitated by the low or slim profile of the sensor provided by the design of the invention. Since the sensor does not need to be in direct contact with the precipitation, the flush or planar surface can be coloured to match for instance a window, without affecting the overall performance of the sensor.

In another embodiment of the invention there is provided a window comprising a precipitation sensor comprising an impact membrane provided with a transducer for detecting impact of precipitation on the impact membrane, a circuit board comprising electric circuit components adapted to receive an electric input signal from said transducer and to produce an output signal, where said electric circuit components and said transducer are mounted on a first side of the circuit board and that a second side of the circuit board comprises said impact membrane.

The invention will now be explained in detail in the following by means of examples of embodiments with reference to the schematic drawing, on which

Fig. 1 illustrates a perspective view of the side of a precipitation sensor comprising electric circuit components,

Fig. 2 and Fig. 3 are perspective views of the membrane side of a precipitation sensor with of embossed surfaces on the membrane sides,

Fig. 4 is a perspective view of a piezoelectric element of a precipitation sensor according to an embodiment of the invention,

Fig. 5 is a perspective view of a precipitation sensor comprising means for rolling up a connection wire,

Fig. 6 is a precipitation sensor comprising comb-toothed prints on the membrane side of the circuit board,

5 Fig. 7 is an exploded view of a precipitation sensor module comprising a housing and precipitation sensor,

Fig. 8 is an exploded view of another embodiment of a precipitation sensor module showing how a precipitation sensor is mounted the opening of a housing,

10 Fig. 9 is a perspective view of a window comprising a precipitation sensor.

In Fig. 1 is shown a preferred embodiment of a precipitation sensor 1 according to the invention comprising a preferably square circuit board 2 having a first side 3 comprising a electric circuitry 4 and a  
15 second side 5 (cf. Fig. 2 or 3), which serves an impact membrane. Besides the electric circuitry 4 which comprises SMD components generally known as SMD's mounted by means of reflow soldering, the first side 3 of the circuit board 2 comprises a transducer 6, which via printed connections (not shown) on the first side 3 or inside said circuit board 2  
20 electrically is connected to the electric circuitry 4 comprising a socket 7, and processing means 8 such as a digital microprocessor. Fig. 2 and Fig. 3 show the second side 5 of the circuit board 2 of a precipitation sensor 1. Since the surface of the second side 5 of the precipitation sensor 1 opposite to the first side 3 comprising the electric circuitry board 4  
25 serves as an impact membrane for the sensor, the membrane and the circuit board 2 are one and the same element. Energy from precipitation such as rain or hail impacting the membrane side will result in a movement or vibration of the impact membrane and hence the circuit board 2 with the electric circuitry 4 and the transducer 6. The transducer 6 will  
30 detect such impacts and produce an output signal to the electric circuit 4, which is adapted to receive a signal from the transducer 6. The design and the components used in the circuitry 4 will depend on the type of the transducer 6 and the properties of the provided output signal from the transducer 6.

In the embodiment illustrated in Fig. 1 the transducer 6 is a piezoelectric element, which produces a very low current as response to impact of precipitation. Hence, the electric circuit 4 is specifically adapted to amplify the output signal of a piezoelectric element. Other conceivable transducers suitable for detecting precipitation impacting the membrane are MEMS transducers, resonators or oscillators, and strain gauges. In Fig. 1 the received and amplified signals are processed by the processing means 8. The processing enables filtering out of vibrations detected by the transducer, which does not originate from precipitation impacting the membrane. The signals can be filtered and processed in many conceivable ways, such as by detecting patterns or duration of detected vibrations. The electric circuitry 4 is powered by means of the socket 7, which besides from being a power source input also is used for outputting a signal from the precipitation sensor 1.

15 It is obvious that the sensor can be provided with more than one socket, in order to serve as a simple cross field for joining for instance control logic of multiple windows.

For the production of the precipitation sensor 1 known soldering techniques and processes, such as reflow soldering, can be used for mounting the components of the electric circuitry 4 and the transducer 6 on the first side 3 of circuit board 2. In a currently preferred embodiment of the invention the precipitation sensor 1 is provided with a piezoelectric element, which is soldered to the circuit board 2 together with the other electric components. The piezoelectric element, which is illustrated in Fig. 4, comprises two opposite silver electrodes 10 and 11. When the piezoelectric element is exposed to a vibration or a similar physical influence there is established a voltage between the two electrodes 10 and 11. In order to ensure a correct position of the piezoelectric element with respect to the other components and the circuit prints on the circuit board 2, the used piezoelectric element is provided with a wrap around 12 of its negative electrode 10 to the side of the positive electrode 11 as illustrated in Fig. 4, meaning that the electrode continuous is wrapped around an edge in order to provide both electrodes on the same side of the piezoelectric element. As the negative electrode 10

is wrapped around an edge of the piezoelectric element to the opposite side of the element comprising the positive electrode 11 and there is provided a isolating area 13 between the two electrodes, it is possible to solder both electrodes of the piezoelectric element to the prints on the circuit board 2 at once, by using standard soldering techniques as described above. Experiments have shown that additional areas 14a, 14b without silver coating in the area of the positive electrode 11 are suitable to ensure that the piezoelectric element is kept in or guided to the correct position after and during the soldering process. It is obvious that a similar result can be achieved by wrapping around the positive electrode 11 to the side of the negative electrode 10.

In a preferred embodiment of the invention, the second side of the circuit board 2 is embossed as illustrated in Fig. 2 and Fig. 3. Experiments have shown that by embossing the surface of the second side of the circuit board 2 the movement or vibration of the membrane caused by impacting precipitation is enhanced, which provides for use of a less sensitive transducer 6. The enhancement is for instance achieved with a waved or grooved structure of the surface of the impact membrane as illustrated in Fig. 2 and Fig. 3 or by combinations thereof. It is to be understood that the membrane side can be embossed and designed in many other ways to enhance the absorption of energy from impacting precipitation. For instance the membrane side can be fitted with a new surface, which is glued to the surface or clicked on the circuit board 2, but preferably the surface of the membrane side is an integrated part of the circuit board 2.

The precipitation sensor 1 is provided with a socket or sockets 7 to connect a connection wire 17 to the precipitation sensor 1 (cf. Fig. 5). Since a precipitation sensor 1 can be utilized for many purposes such a different types of windows, the first side 3 of the circuit board 2 has means for rolling the unused part of said connection wire 17. An embodiment comprising this feature is illustrated in Fig. 5 where the first side 3 of the circuit board 2 is provided with protruding walls 18a, 18b, 18c which constitutes a canal or labyrinth for guiding and rolling up the unused part of said wire and thereby adapting it to its specific use.

Guiding can be understood as help to adjust the correct length of the connection wire 17 extending from the precipitation sensor 1 in order to adapt said wire 17 to a specific purpose. This can be achieved by means of guiding instructions such as colour codes or symbols and letters provided in the canals, labyrinths or at said walls 7a, 7b, 7c.

Fig. 6 shows an embodiment of the invention where the impact membrane is provided with comb-toothed prints 19, which are used for detecting a change in capacitance or resistance between the prints when the membrane side gets wet or dries. It is to be understood that the prints can have many shapes and that they are not restricted to comb-toothed prints as illustrated. Alternatively, the same result could be achieved with two or more substantially concentric circular print tracks or simply with two adjacent circuit print tracks.

In Fig. 7 and Fig. 8 the precipitation sensor 1 is adapted to be mounted in an opening 20 of a housing 21, in order to provide a precipitation sensor module comprising a housing 21 and a precipitation sensor 1. Fig. 7 shows a precipitation sensor 1 adapted to cover the opening 20 of a housing 21 so that the components of the circuit board 3 are located inside the housing 21. The precipitation sensor 1 can be fixed to the housing in many different ways such as by gluing, by using snap arrangements or fastening means known per se by the person skilled in the art.

Alternatively, the precipitation sensor can be mounted in a window 24 as shown in Fig. 9 where the precipitation sensor 1 is integrated in a top covering member 25 of a roof window and the connection wire 17 (not shown) is connected to a window controlling device. The sensor is normally driven by a power source from the window 24, but it can also be driven by a renewal or replaceable energy source. The precipitation sensor 1 can also be an integrated part of the window 24 due to the constituent impact surface 5, which provides a flush and planar surface with a pleasant appearance. In general the precipitation sensor 1 according to the invention is particularly useful to be retrofitted in conjunction with windows or similar building arrangements, which are able to utilize a sensor output for controlling purposes.

The invention should not be regarded as limited to the embodiments shown and described in the above, but several modifications and combinations may be carried out without departing from the scope of the appended claims.

## P A T E N T C L A I M S

1. A precipitation sensor comprising  
an impact membrane provided with a transducer for detecting  
5 impact of precipitation on the impact membrane,  
a circuit board comprising electric circuit components adapted  
to receive an electric input signal from said transducer and to produce  
an output signal, c h a r a c t e r i z e d in that  
said electric circuit components and said transducer are  
10 mounted on a first side of the circuit board and that a second side of the  
circuit board comprises said impact membrane.
2. A precipitation sensor according to claim 1, c h a r a c t e r -  
i z e d in that said circuit board and impact membrane are one and  
the same element.
- 15 3. A precipitation sensor according to claim 1 or 2, c h a r a c -  
t e r i z e d in that the surface of said second side of the circuit board  
is embossed to provide an uneven surface.
4. A precipitation sensor according to any of the previous  
claims, c h a r a c t e r i z e d in that said circuit board comprises  
20 means for rolling up a connection wire.
5. A precipitation sensor according to any of the previous  
claims, c h a r a c t e r i z e d in that that said transducer is a piezo-  
electric element.
6. A precipitation sensor according to claim 5, c h a r a c t e r -  
25 i z e d in that said piezoelectric element is soldered to said first side of  
the circuit board.
7. A precipitation sensor according to any of the previous  
claims, c h a r a c t e r i z e d in that said second side of the circuit  
board comprises at least two adjacent circuit prints.
- 30 8. A precipitation sensor according to any of the previous  
claims, c h a r a c t e r i z e d in that said circuit board is adapted to  
mounted in an opening of a housing.
9. A window comprising a precipitation sensor comprising  
an impact membrane provided with a transducer for detecting

impact of precipitation on the impact membrane,

a circuit board comprising electric circuit components adapted to receive an electric input signal from said transducer and to produce an output signal, characterized in that

5 said electric circuit components and said transducer are mounted on a first side of the circuit board and that a second side of the circuit board comprises said impact membrane.

10 10. A window according to claim 9, characterized in that said circuit board and impact membrane are one and the same element.

11. A window according to claim 9 or 10, characterized in that the surface of said second side of the circuit board is embossed to provide an uneven surface.

15 12. A window according to any of the previous claims, characterized in that said circuit board comprises means for rolling up a connection wire.

13. A window according to any of the previous claims, characterized in that that said transducer is a piezoelectric element.

20 14. A window according to claim 9, characterized in that said piezoelectric element is soldered to said first side of the circuit board.

15. A window according to any of the previous claims, characterized in that said second side of the circuit board comprises at least two adjacent circuit prints.

1/5

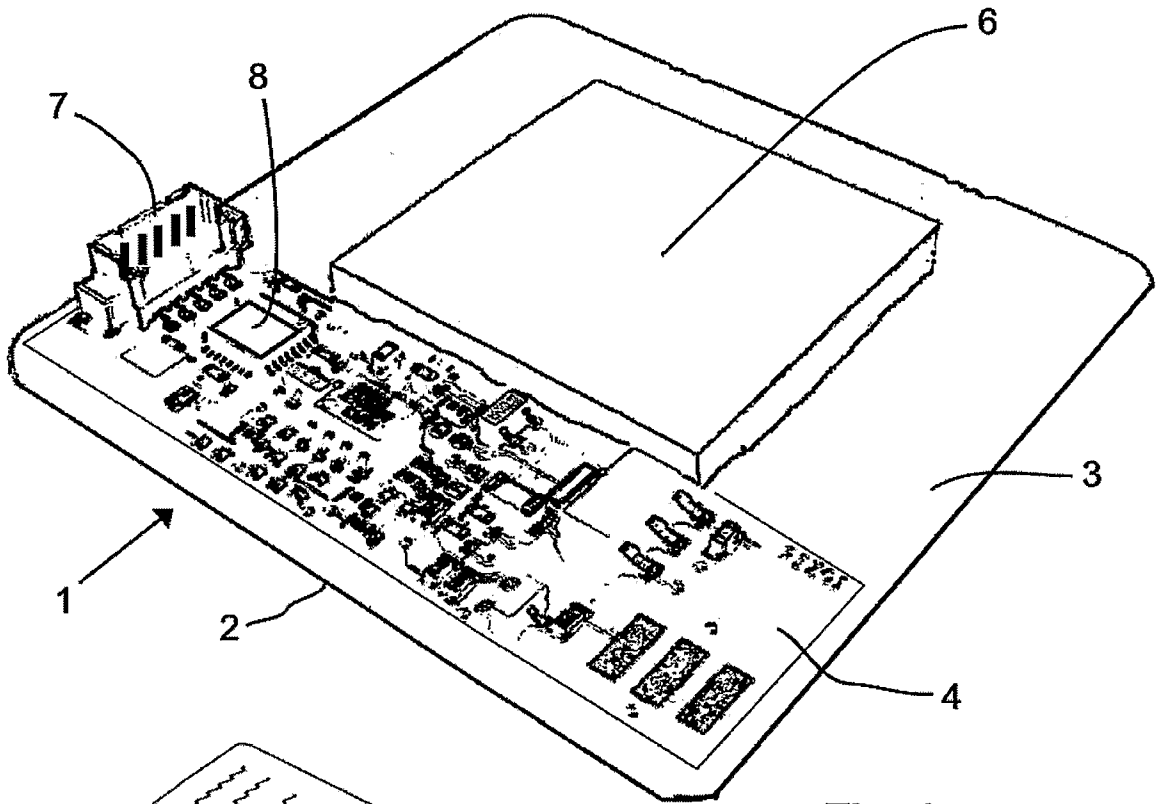

Fig. 1

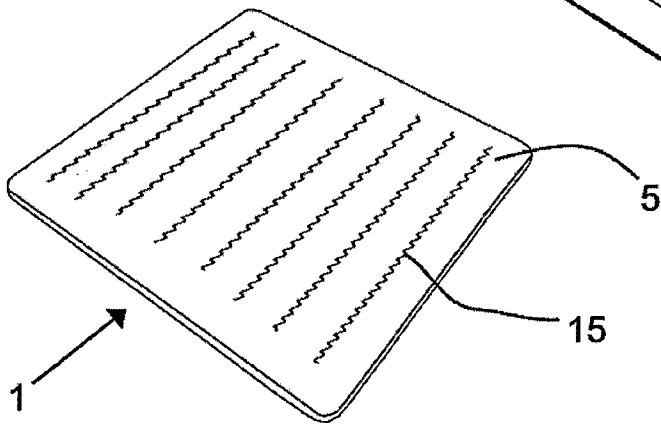

Fig. 2

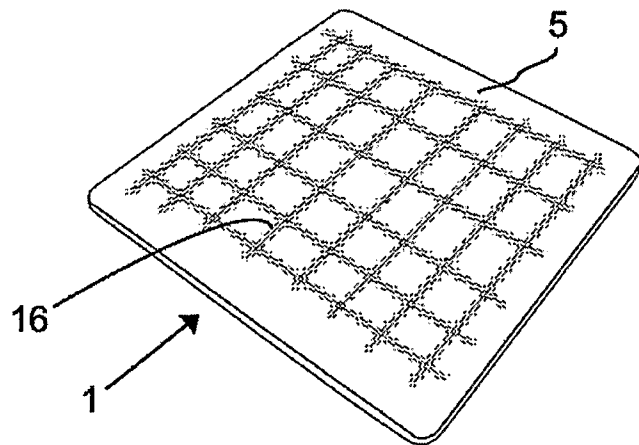

Fig. 3

2/5

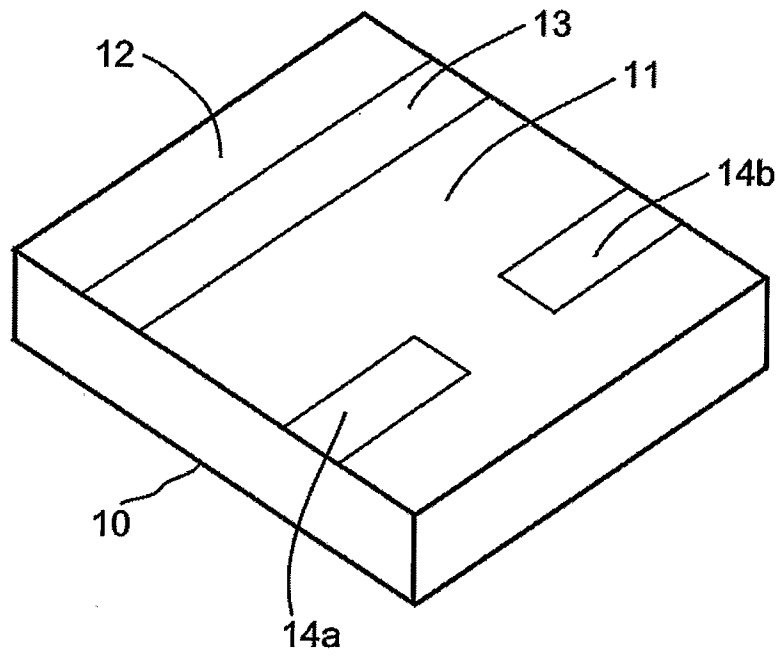
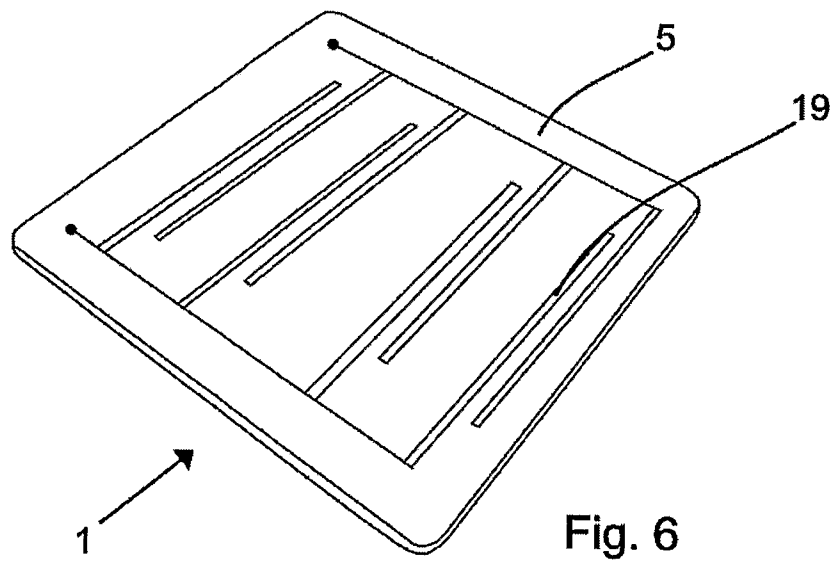
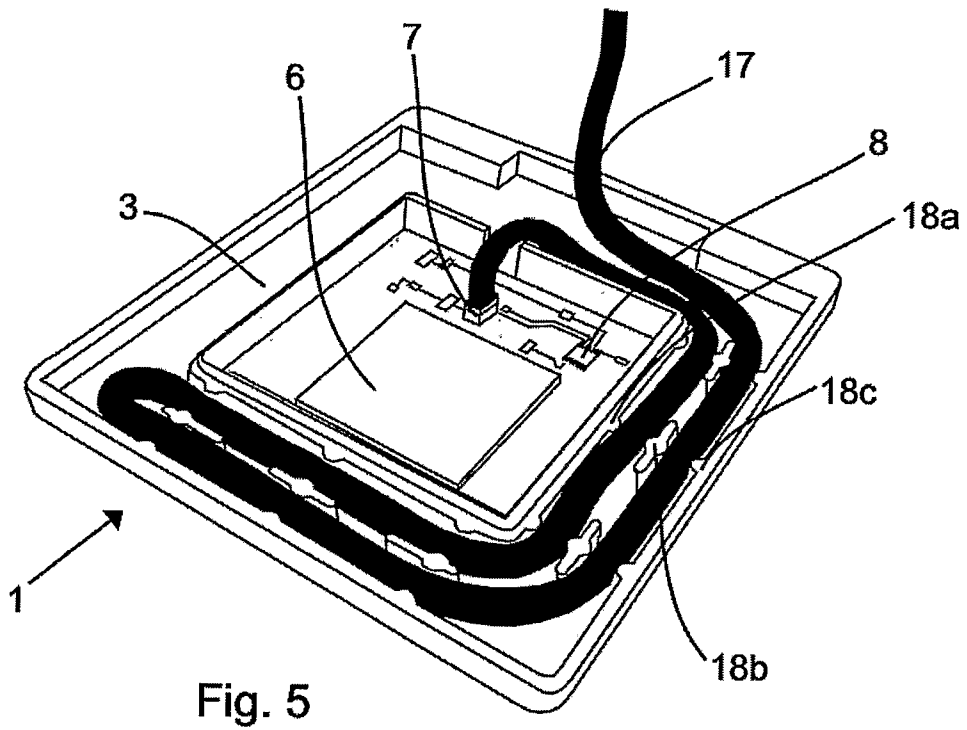

Fig. 4

3/5



4/5

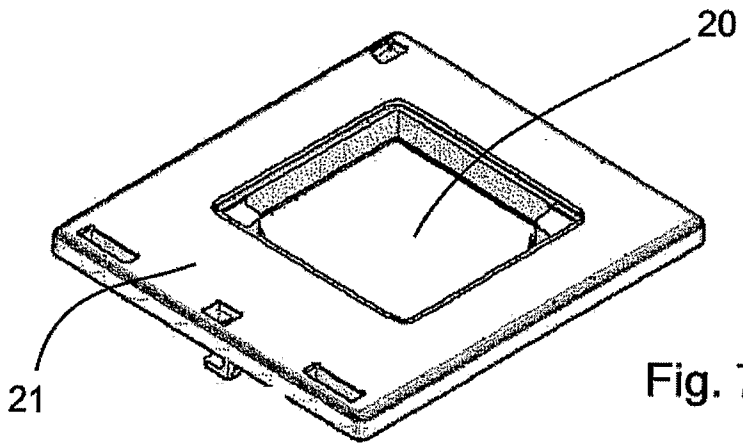
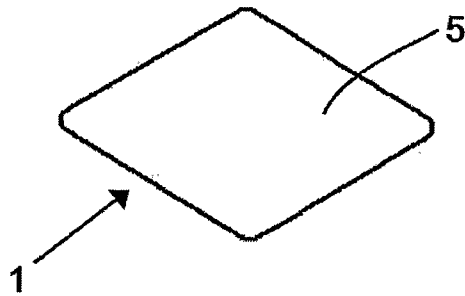

Fig. 7

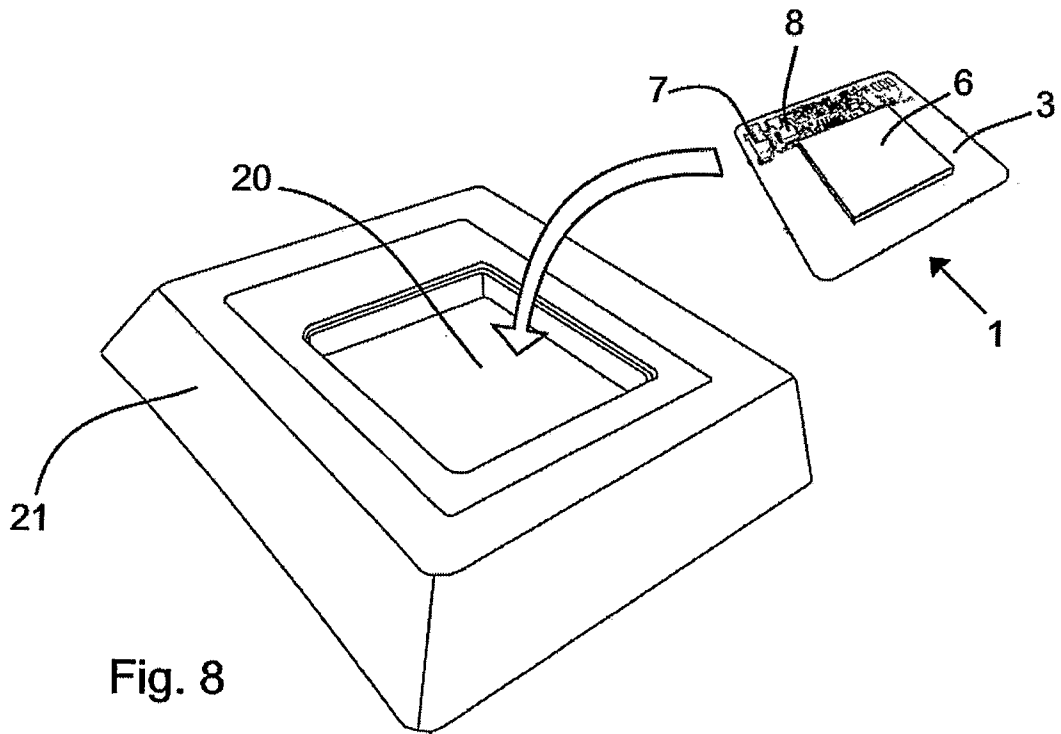

Fig. 8

5/5

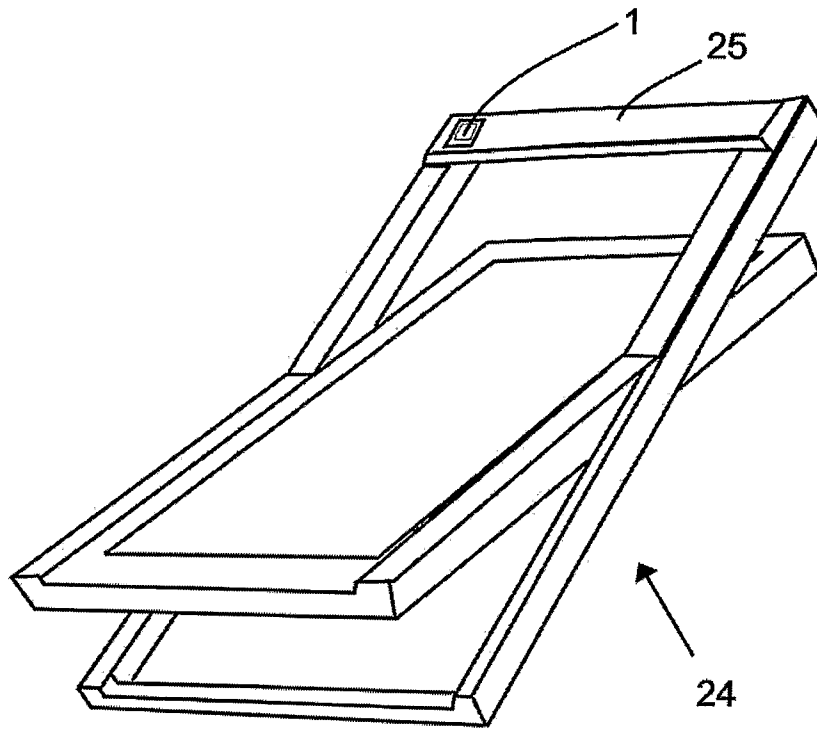

Fig. 9

**INTERNATIONAL SEARCH REPORT**

International application No  
PCT/DK2008/000236

**A. CLASSIFICATION OF SUBJECT MATTER**  
INV. G01W1/14

According to International Patent Classification (IPC) or to both national classification and IPC

**B. FIELDS SEARCHED**

Minimum documentation searched (classification system followed by classification symbols)  
G01W B60S

Documentation searched other than minimum documentation to the extent that such documents are included in the fields searched

Electronic data base consulted during the international search (name of data base and, where practical, search terms used)

EPO-Internal, WPI Data

**C. DOCUMENTS CONSIDERED TO BE RELEVANT**

Category*	Citation of document, with indication, where appropriate, of the relevant passages	Relevant to claim No.
X	US 2005/017666 A1 (PANKEY ET AL) 27 January 2005 (2005-01-27) abstract; figures paragraphs [0002], [0016] - [0022], [0031] - [0033]	1-15
A	GB 2 412 735 A (WRC PLC) 5 October 2005 (2005-10-05) cited in the application the whole document	1-15
A	DE 10 2006 032372 A1 (PREH GMBH [DE]) 15 February 2007 (2007-02-15) abstract; figures 2,5	1,2

Further documents are listed in the continuation of Box C.

See patent family annex.

\* Special categories of cited documents:

- \*A\* document defining the general state of the art which is not considered to be of particular relevance
- \*E\* earlier document but published on or after the international filing date
- \*L\* document which may throw doubts on priority claim(s) or which is cited to establish the publication date of another citation or other special reason (as specified)
- \*O\* document referring to an oral disclosure, use, exhibition or other means
- \*P\* document published prior to the international filing date but later than the priority date claimed

- \*T\* later document published after the international filing date or priority date and not in conflict with the application but cited to understand the principle or theory underlying the invention
- \*X\* document of particular relevance; the claimed invention cannot be considered novel or cannot be considered to involve an inventive step when the document is taken alone
- \*Y\* document of particular relevance; the claimed invention cannot be considered to involve an inventive step when the document is combined with one or more other such documents, such combination being obvious to a person skilled in the art.
- \*Z\* document member of the same patent family

Date of the actual completion of the international search

26 September 2008

Date of mailing of the international search report

10/10/2008

Name and mailing address of the ISA/

European Patent Office, P.B. 5818 Patentlaan 2  
NL - 2280 HV Rijswijk  
Tel. (+31-70) 340-2040, Tx. 31 651 epo nl,  
Fax: (+31-70) 340-3016

Authorized officer

Barthélemy, Matthieu

# INTERNATIONAL SEARCH REPORT

Information on patent family members

International application No
PCT/DK2008/000236

Patent document cited in search report	Publication date	Patent family member(s)	Publication date
US 2005017666 A1	27-01-2005	WO 2005016711 A1	24-02-2005
GB 2412735 A	05-10-2005	NONE	
DE 102006032372 A1	15-02-2007	EP 1966011 A2	10-09-2008
		WO 2007009767 A2	25-01-2007
		US 2008223127 A1	18-09-2008