

H. E. MARCHAND.

BALANCE-VALVE.

No. 187,157.

Patented Feb. 6, 1877.

Fig. 1.

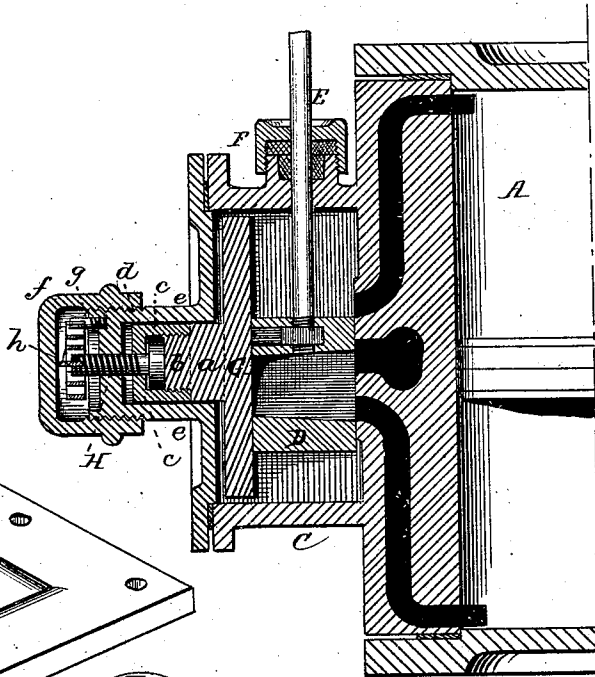

Fig. 3.

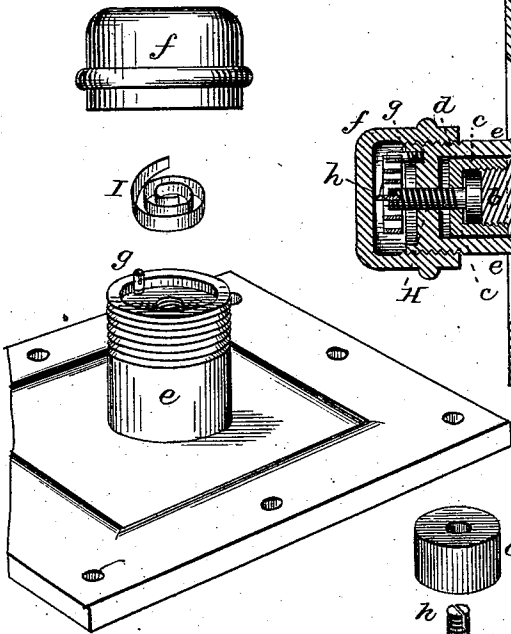
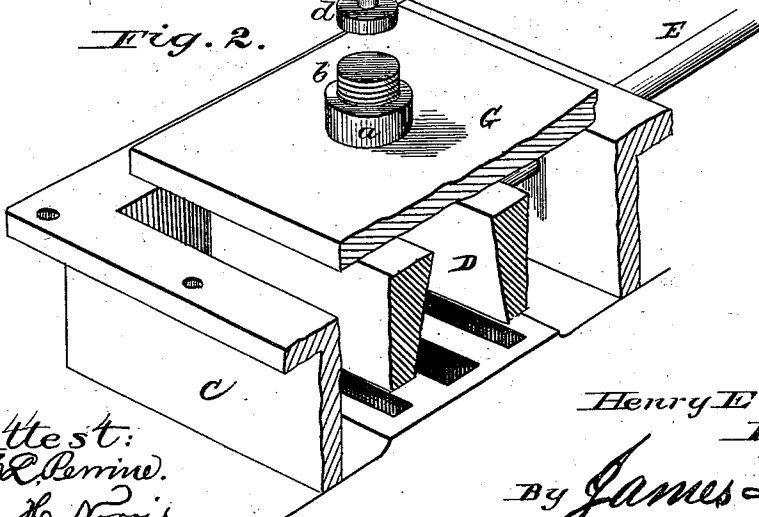

Fig. 2.



Attest:
W. L. Perrine.
W. L. Norris.

Henry E. Marchand
Inventor.
By James L. Norris.
Attorney.

UNITED STATES PATENT OFFICE

HENRY E. MARCHAND, OF ALLEGHENY, PENNSYLVANIA.

IMPROVEMENT IN BALANCE-VALVES.

Specification forming part of Letters Patent No. **187,157**, dated February 6, 1877; application filed January 9, 1877.

To all whom it may concern:

Be it known that I, HENRY E. MARCHAND, of Allegheny city, in the county of Allegheny and State of Pennsylvania, have invented new and useful Improvements in Balance-Valves, of which the following is a specification:

This invention relates to certain improvements in balanced valves for steam-engines; and has for its object to furnish an automatic means of keeping the valve upon its seat; and to this end my invention consists in combining with a slide-valve a balance-plate provided with a screw-stem projecting through a stuffing-box in the top of the valve-chest; said stem being connected to a spring which automatically turns the screw-stem, and serves to keep the balance-plate pressed uniformly upon the valve, and compensates for the wear of the bearing-faces of said plate and valve, at the same time perfectly balancing the valve, as will be more fully hereinafter described.

In the drawing, Figure 1 represents a central longitudinal section of a portion of the cylinder of an engine, showing my invention applied thereto; Fig. 2, a detached perspective view of the top of the valve-chest, the spring, and the screw-cap; and Fig. 3 a detached perspective view, partly in section, of the valve-chest, valve, balance-plate, and compensating-screw.

The letter A represents a portion of the cylinder of a steam-engine; C, the valve-chest; D, the slide valve; and E, the valve-rod, extending through the usual stuffing-box F. G represents the balance-plate, which rests upon the upper surface of the valve D, and upon its top portion, at the center thereof, is constructed a projection, *a*, having a reduced screw-threaded shank, *b*, upon which is fitted a screw-cap, *c*, and in a recess between the upper end of this screw-shank *b*, and the inside of the cap *c*, is confined the head *d* of a compensating-screw, H, said screw projecting upwardly through an aperture in the cap *c*. This projection *a* of the balance-plate G, its cap *c*, and screw H, are located in a chambered projection, *e*, on the valve-

chest, and the outside of said projection is screw-threaded, and provided with a screw-cap, *f*. The upper end of the chambered projection *e* is provided with a stud, *g*, to which one end of a convolute or other suitable spring, I, is attached, the other end of the spring being attached to the compensating-screw, in the present instance, by slipping the end of the spring in a slot, *h*, in the upper end of said screw. The spring has sufficient power to turn the compensating-screw when the pressure of steam is not upon the top of the balance-plate, (as is fully described in an application for Letters Patent allowed to me December 20, 1876,) but when the steam is admitted to the top of the valve, for reversing the motion of the engine, then the screw and spring remain stationary, firmly retaining the slide-valve on its seat.

By the means described, I provide an efficient balance slide-valve, and the operation of the screw and spring thoroughly and effectually compensates for any wear between the bearing-faces of the valve and the balance-plate, and keeps said valve at all times truly and evenly upon its seat.

What I claim, and desire to secure by Letters Patent, is—

1. The combination, with the slide-valve of an engine, of a balance-plate, a compensating screw-bearing upon the same, and a spring connected with the screw, for balancing the valve and compensating for wear, substantially as and for the purpose described.

2. The combination, with a slide-valve, D, of the balance-plate G, having the projection *a* and screw-shank *b*, the compensating-screw H having the head *d*, the cap *c* confining said screw in place, and the spring I connected with the screw, substantially as and for the purpose described.

In testimony that I claim the foregoing I have hereunto set my hand in the presence of the subscribing witnesses.

HENRY E. MARCHAND.

Witnesses:

W. D. PORTER,
R. W. MILLER.