

Oct. 9, 1951

L. R. SABO

2,570,865

SWING-AWAY LAVATORY STOOL

Filed Feb. 25, 1947

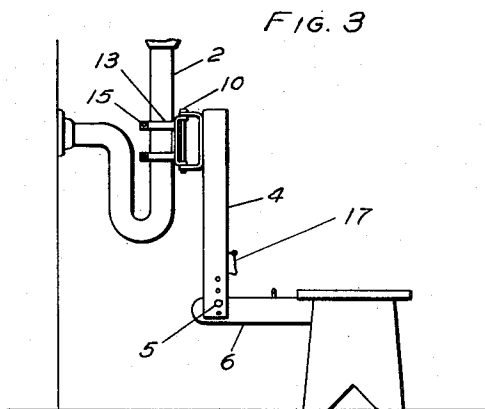
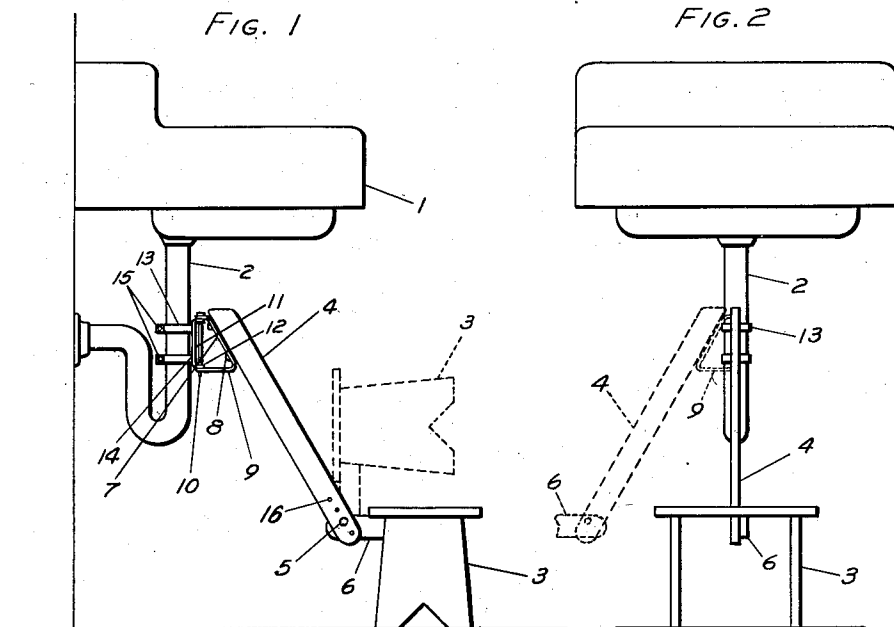

INVENTOR.
LOUIS R. SABO
BY
C. E. Robinson
attorney

UNITED STATES PATENT OFFICE

2,570,865

SWING-AWAY LAVATORY STOOL

Louis R. Sabo, Mariemont, Ohio

Application February 25, 1947, Serial No. 730,790

7 Claims. (Cl. 155—80)

1

This invention relates to a swing-away foot stool in combination with a lavatory, and, more particularly, to one which is attached to some part of the lavatory or a support behind same, and can be swung around to the front or either side thereof from a swing-away position from under the lavatory for use.

The foot stool is particularly useful for children, and is such that it can be readily manipulated by them from a swing-away position under the lavatory into a proper place for standing thereon for convenient use of the lavatory. When not in use, the foot stool can be lifted and swung back in swing-away position beneath the lavatory, there being provided a suitable backing support against which the foot stool can rest when in swing-away position. The backing support may be inclined so that the foot stool is past dead center and will rest by gravity against the backing support or if not past dead center a catch mechanism may be provided to retain the foot stool in lifted back position against the backing support.

Generally described, the invention comprises a back support having one end pivotally connected to the drain conduit from the lavatory, or the leg or support if the lavatory is of the type which is provided with such, whereby the back support may be swung around on a vertical axis. A foot stool is pivoted to the opposite end of the back support to be dropped to the floor in position for use, and when not in use can be lifted back against the back support out of position. Foot stools of different heights, or one with adjustable legs, may be used, and thus the pivotal connection is such to permit adjustment of the pivot at selected elevations.

For a better understanding of the invention, reference is made to the accompanying drawings, in which:

Fig. 1 is a side elevation of a device embodying the invention attached to a lavatory;

Fig. 2 is a front view of the device shown in Fig. 1; and

Fig. 3 is a side elevation of another embodiment of the invention.

Referring specifically to the drawings in which like numerals are used to designate like parts, numeral 1 is a conventional lavatory which is fixed to a wall or otherwise supported in position and has an outlet drain conduit 2 leading from the bottom.

A swing-away foot stool 3 is attached to the drain conduit by a jointed connection which comprises a back support 4, preferably disposed

2

at an angle so that the foot stool can be swung back against it, past dead center, in order to be retained in such position without any other holding means. The foot stool is pivoted to the back support at 5. Rather than have the foot stool directly pivoted to the back support, an extension arm 6 may be advantageously provided between the foot stool and the back support to have one end pivoted to the back support and the other end fixed to the foot stool. The arm may be fixed to the foot stool in any suitable manner. The extension arm permits disposition of the back support back under the lavatory where it is out of the way, as is the foot stool, when the foot stool is in swing-away position on the back support. The bottom end of the back support preferably terminates somewhat above the floor. To use the foot stool, it needs only to be dropped down in place from swing-away position. It is always in place to be easily reached, and, when not in use, can be easily lifted and swung back to swing-away position.

The foot stool connection may also be advantageously constructed to provide a vertical axis for swinging the foot stool around to the front or either side of the lavatory. In Fig. 2, the device, as shown by the full lines, is in front of the lavatory, whereas, as shown by the dotted lines, it is swung to one side of the lavatory. It can be swung to any desired position in front or at either side of the lavatory. This may be obtained by a joint connection between the back support and the connection to the drain conduit or other fixed support.

A suitable swinging joint connection is typified by a block or strap having a diagonal face 7 mating with a portion of one side of the back support and secured thereto by screws 8. Angular flanges 9 project from opposite ends of the diagonal face 7 with perforations or eyes therein for receiving a pivotal bolt 10.

Associated with the block or strap is a U-shaped member 11 having opposite angular flanges 12 with perforations or eyes therein for also receiving the bolt 10 which pivots the block or strap to the U-shaped member.

The U-shaped member has one or more clamps 13 fixed thereto at one end, such as by welding at point 14, and open at the opposite end to fit over the conduit. The open ends of the clamp are advantageously provided with a bolt 15 to draw the sides of the clamp against the conduit. The clamps 13 permit the device being attached in proper position to the drain conduit, and they

3

may be readily adjusted for foot stools of different heights. However, to facilitate more convenient adjustment for use of different height foot stools, a series of perforations 16 may be advantageously provided in the lower end of the back support, any one of which may be selected for attaching thereto the arm 6 on the foot stool.

Any suitable pivot means can be provided for connecting the foot stool to the back support and the back support to the conduit, these being such as to provide for swinging the foot stool around a vertical axis and also for swinging the foot stool away from and back upon the back support.

In the embodiment of Figs. 1 and 2, the back support 4 is inclined so that the foot stool when lifted on its axis will be past dead center, thereby causing it to be retained in lifted position by gravity.

The back support 4 in the embodiment of Fig. 3 is perpendicular, and, therefore, any conventional catch mechanism 17 may be employed for holding the foot stool in lifted position and readily releasing same when pulled down for use.

While I have described embodiments of the invention in detail, it will be understood that there may be various changes in details of construction without departing from the spirit of the invention.

I claim:

1. In combination with a lavatory, a back support pivotally attached by a vertical pivot to a fixed support adjacent the lavatory to be supported at an angle to the vertical pivot, and a foot stool pivoted to the back support in position to rest on the floor and adapted to be swung away against the back support and be retained by gravity in swung-away position.

2. In combination with a lavatory, a back support pivotally attached by a vertical pivot to a fixed support adjacent the lavatory to be supported at an angle to the vertical pivot and to swing about said lavatory, and a foot stool pivoted to the back support for being swung away against the back support and retained by gravity in swung-away position.

3. A swing-away stool comprising a back support having an attachment with a vertically extending pivot for connection to a support to be supported at an angle to the vertical pivot, and a foot stool portion pivoted to the back support for being swung away from operative position on the floor to be held by gravity against the inclined back support.

4. In combination with a lavatory, a foot stool beside said lavatory, a back support pivoted to

4

the lavatory for being swung thereabout, and a pivotal connection between the foot stool and the back support whereby said stool can be swung from an operative position on the floor to an in-operative position off the floor and against the back support.

5. In combination with a lavatory having a waste pipe, a back support pivotally attached to the waste pipe of the lavatory, and a foot stool pivoted to the back support for permitting swinging of said foot stool into position on the floor in front of the lavatory from against said back support.

6. In combination with a lavatory having a waste pipe, a back support pivotally attached to the waste pipe of the lavatory to swing about said lavatory on a vertical axis, and a foot stool pivoted to the back support on a horizontal axis for permitting swinging of said foot stool into position on the floor in front of the lavatory from against said back support.

7. A swung-away stool comprising an inclined back support having a pivotal attachment for connection to a fixed support whereby the back support may be swung relatively to the fixed support on a vertical axis, a foot stool, and means connected to the foot stool for pivotally connecting same to the lower end of the back support on a horizontal axis whereby the stool may be swung up from a position on the floor to bear against the inclined back support to be held by gravity in swung-up position.

LOUIS R. SABO.

REFERENCES CITED

The following references are of record in the file of this patent:

UNITED STATES PATENTS

Number	Name	Date
190,896	Peard	May 15, 1877
399,388	Dunn	Mar. 12, 1889
491,590	Boulson	Feb. 14, 1893
610,143	Lind	Aug. 30, 1898
684,937	Johnson	Oct. 22, 1901
958,529	Phillips	May 17, 1910
1,219,324	Johnson	Mar. 13, 1917
1,457,582	Lewandowski	June 5, 1923
1,491,039	Voina-Hansen	Apr. 22, 1924
2,339,647	Meyer	Jan. 18, 1944

FOREIGN PATENTS

Number	Country	Date
25,070	Denmark	1919

55