

June 4, 1940.

K. S. ROGERS

2,203,106

MOP

Filed Sept. 27, 1937

2 Sheets-Sheet 1

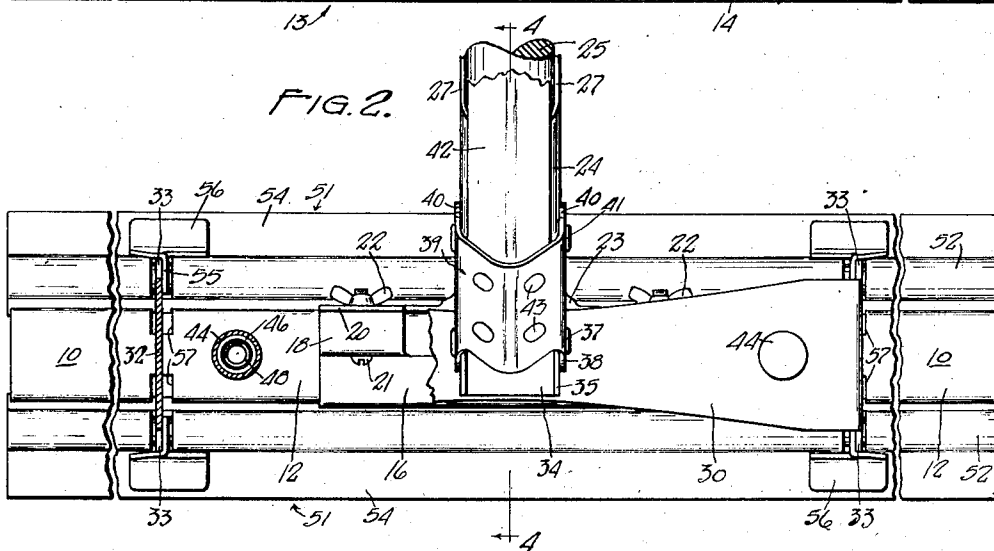
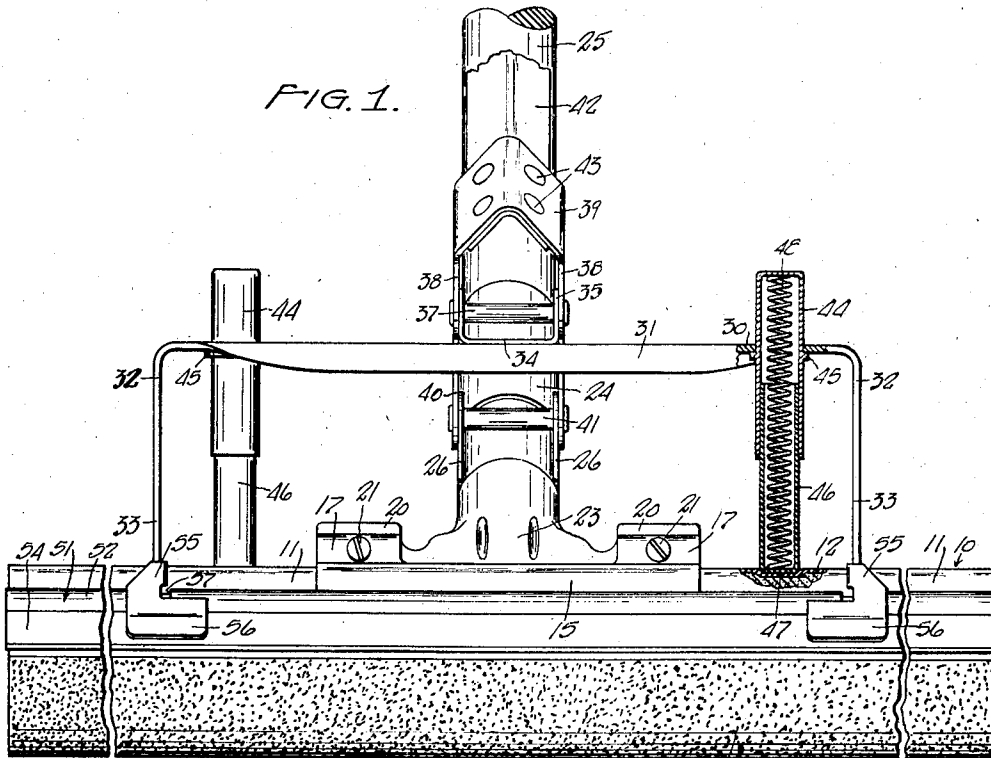

INVENTOR.
KENNETH S. ROGERS.
BY *Ultech & Knoblock*
ATTORNEYS.

June 4, 1940.

K. S. ROGERS

2,203,106

MOP

Filed Sept. 27, 1937

2 Sheets-Sheet 2

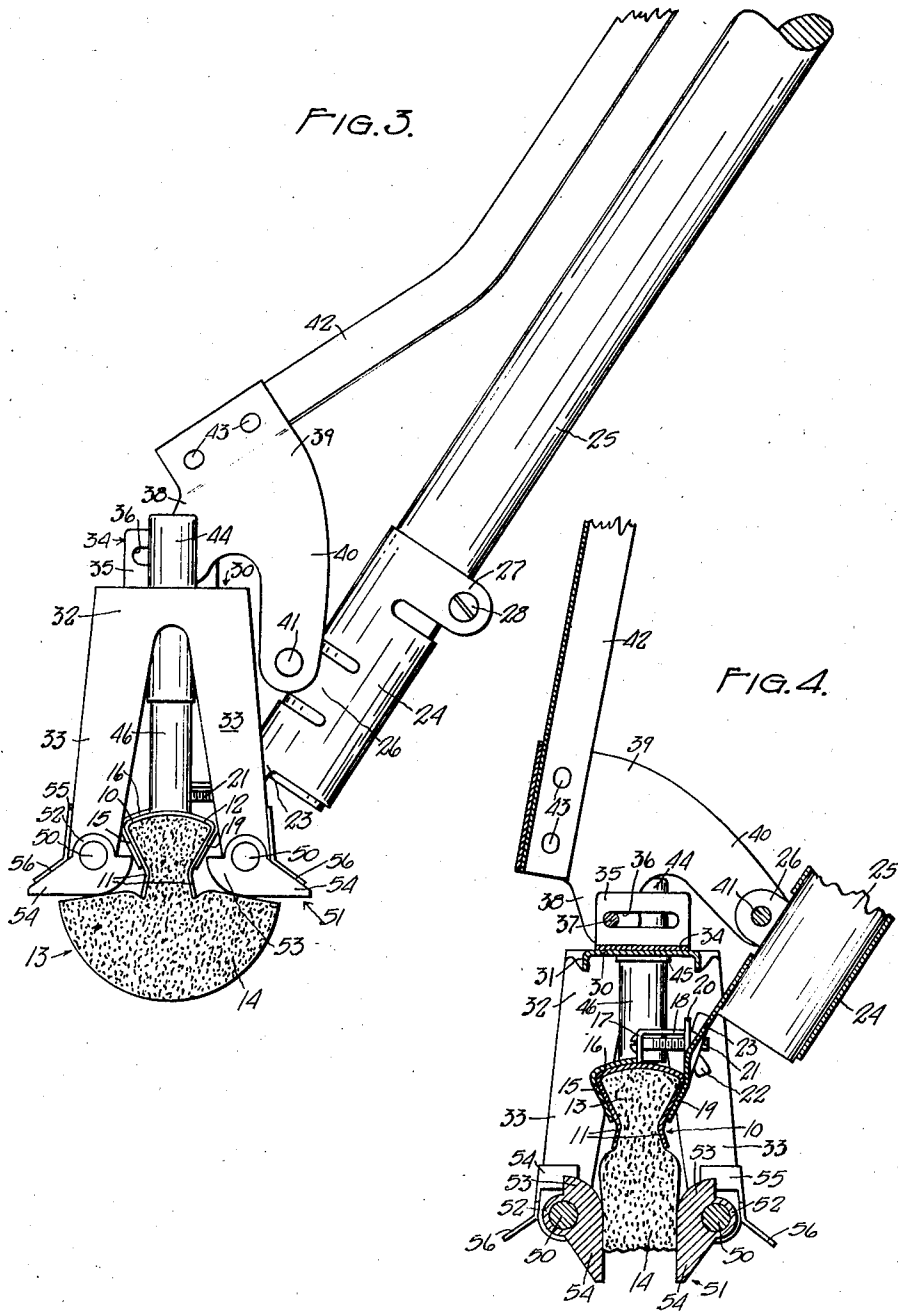

INVENTOR.
KENNETH S. ROGERS.
BY *Oltsch & Knoblock*
ATTORNEYS.

UNITED STATES PATENT OFFICE

2,203,106

MOP

Kenneth S. Rogers, Niles, Mich.; Francis J. Miller, administrator of said Kenneth S. Rogers, deceased, assignor, by mesne assignments, to Levant C. Rogers, Niles, Mich.

Application September 27, 1937, Serial No. 165,801

9 Claims. (Cl. 15—119)

This invention relates to improvements in mops, and particularly to a mop employing sponge rubber as a mopping element and of the general type illustrated in my copending patent application, Serial No. 44,568, filed October 11, 1935, now Patent No. 2,108,727, issued February 15, 1938.

The primary object of this invention is to provide a mop of this character with novel means for extracting water from the sponge mopping element.

A further object is to provide a mop of this character with a rotatable water extracting element having an elongated substantially flat face adapted to press against the sponge mopping element in a combined rolling and flat plate action which effectively extracts water from the full extent of the mopping element.

A further object is to provide a mop of this character with resilient means normally holding the water extracting means and the operating means therefor in stationary inoperative position.

A further object is to provide a mop of this character with novel means for operating a water extracting member.

Other objects will be apparent from the description and appended claims.

In the drawings:

Fig. 1 is a fragmentary view of the mop in front elevation, with parts shown in section.

Fig. 2 is a fragmentary top plan view of the mop.

Fig. 3 is a fragmentary side view of the mop.

Fig. 4 is a fragmentary transverse vertical sectional view taken on line 4—4 of Fig. 2.

Referring to the drawings, which illustrate the preferred embodiment of the invention, the numeral 10 designates a channel member formed of sheet metal and comprising complementary configured side walls 11 interconnected by a transverse web portion 12 from which the side walls 11 extend in generally converging relation whereby the outer portions thereof are spaced apart a distance substantially less than the width of web portion 12. Within channel 10 is mounted a portion of a mopping element 13 formed of sponge rubber and so compressed in said channel as to be tightly held and gripped therein. The portion 14 of the mopping element which projects from the channel flares outwardly from the mouth of the channel whereby its outer surface is of curved contour, as best shown in Fig. 3.

Channel 10 is mounted in a bracket intermediate its ends, said bracket comprising two parts

which are secured together to clamp the channel. The front part 15 of the bracket consists of a plate portion bearing against the front wall 11 of the channel and having an integral bent flange 16 bearing on the web 12 of the channel. At each end of flange 16 is provided a substantially perpendicularly outwardly bent ear 17 which terminates in a rearwardly bent end portion 18 spaced from and substantially parallel to channel web 12. The rear part 19 of the bracket comprises a plate portion which bears against the rear wall 11 of the channel and is provided with upwardly projecting ears 20 against which the rear edges of portions 18 of the front bracket part bear. Bracket parts 17 and 20 are provided with aligned apertures through which a bolt 21 extends, which bolt receives a wing nut 22 for drawing the bracket parts into clamping engagement on channel 10. Integrally formed with bracket part 19 intermediate ears 20 thereof is a rearwardly upwardly inclined configured support 23 for a sleeve 24 which fits around the lower end of an elongated mop handle 25. Sleeve 24 is cut away adjacent its lower end to provide a pair of opposed parallel ears 26 projecting forwardly and upwardly therefrom; and is also configured to provide opposed rearwardly and downwardly projecting ears 27 interconnected by a bolt 28 or other suitable means by which said ears 27 may be drawn together to clamp the sleeve on handle 25.

As seen from the front, a U-shaped rigid frame fits over channel 10 and comprises a back 30 preferably reinforced by angularly bent flanges 31 extending longitudinally thereof, and perpendicularly bent ends 32, each comprising a pair of aligned diverging legs 33. A U-shaped bracket 34 is secured at its back to the center of back 30 of the frame, and the legs 35 of bracket 34 are provided with opposed elongated horizontal slots 36. A pin or rivet 37 extends loosely through slots 36 and is carried by opposed forwardly downwardly extending ears 38 of a substantially U-shaped bell crank or bracket 39. A pair of opposed elongated arms 40 extending downwardly from said bracket 39 at the rear thereof are pivoted by a rivet 41 to ears 26 of sleeve 24. An elongated lever 42 is secured at one end to bracket 39 by rivets 43 and extends rearwardly and upwardly from said bracket in normally spaced and substantially parallel relation to handle 25.

Back 30 of the U-shaped frame is provided with an aperture adjacent each end for the reception of a tubular member 44 having its upper

end closed which is provided with a circumferential flange 45 intermediate its ends adapted to bear on the bottom face of back 30. Into the open lower end of tubular member 44 a second tubular member 46 fits in telescoping relation, the lower closed end of tube 46 preferably seating in a depressed off-set 47 in the back 12 of channel 10. A coil spring 48 enclosed within tubes 44, 46 serves to press said tubes apart and thereby hold the frame 30, 32 in raised relation to channel 10, as illustrated in Fig. 3.

The lower end of each frame arm 33 is apertured to receive an end of a shaft 50, there being two such shafts parallel to and spaced from channel 10 and normally opposite channel sides 11. Each shaft 50 mounts a wringing member 51 of cam section. Members 51, as here illustrated, comprise a small diameter portion 52 of substantially semi-circular extent and concentric of shaft 50, said portions 52 being upwardly positioned when said members are inoperative. The normally lower inward portion 53 of members 51 is of enlarged diameter and substantially a quadrant in extent; and the remainder of each member 51 comprises a substantially triangular portion 54 whose lower face merges with the face of enlarged arcuate portion 53 and is normally substantially horizontally positioned. The wringing members 51 are preferably formed of hard rubber fixed on shaft 50, which shaft is journaled in arms 33 of the frame. Fixedly secured to frame arms 33 adjacent the lower ends thereof are brackets 55 from which outwardly downwardly inclined flange stops 56 project to be engaged by the upper faces of portions 54 of members 51. Channel 10 is preferably cut away or notched at 57 at the sides and back thereof, to accommodate depression of frame 30, 32 relative thereto, the arms 33 at each end of said frame being spaced apart slightly more than the width of said channel adjacent their lower ends and converging upwardly. The spacing of arms 33 is preferably just sufficient to permit lengthwise withdrawal and insertion of channel 10 relative to the frame.

The device is operated by means of lever 42 which tends to depress frame 30 upon being swung away from handle 25. Springs 43 resist the depression of frame 30 and serve to hold said frame in horizontal position while being depressed. As frame 30 is depressed relative to channel 10 and sponge 13, the members 51 bear upon sponge portion 14 at arcuate portion 53 thereof to compress and wring said sponge. This compression of the sponge, combined with continued frame depression, serves to rock members 51 relative to their supporting arms so that the normally aligned bottom faces of portions 54 thereof are inwardly positioned in substantially parallel relation, as illustrated in Fig. 4 when the maximum extent of frame movement by lever 42 permitted by elongated slot 36 is reached. In this position, the portions 54 of members 51 project beyond the compressed bottom portion of the sponge, so that the full extent of projecting sponge portion 14 is compressed to insure complete extraction of water therefrom. Thereafter, upon pivoting of handle 42 to normal position, the same frictional engagement of members 51 with the sponge, coupled with the upward movement of the frame 30, serves to rock the members 51 reversely to their normal or starting position. The stops 56 serve to limit this reverse rocking to the proper extent for positioning said members to insure the frictional rock-

ing upon the succeeding downward movement of frame 30. The springs 48 insure raising and normal positioning of the frame 30, wringers 51 and associated parts in inoperative position illustrated in Fig. 3 to prevent interference of the wringer assembly with the mopping action.

The mop may be readily assembled and disassembled. Thus, to disassemble the device, the tubular members may be telescoped against the action of spring 48 sufficiently to release member 46 from its seat 47 and permit the tubes to be angularly swung to be released from the apertures in frame back 30. Thumb nuts 22 can then be loosened to release the channel from its mounting bracket and permit lengthwise withdrawal of channel 10 from frame 30.

The cam shape of the wringer members 51 permits complete wringing of the sponge, even when the sponge has become stretched in use; and at the same time prevents over-running of the sponge by said members with consequent objectionable sponge expansion above or inwardly of the extended wringers which would retard return of the wringers to inoperative position with possible damage to the sponge or distortion and pinching thereof between the channel and wringer when the latter was forced to normal elevated position. In other words, this cam wringer combines the automatic rocking action of a roll wringer with the efficiency and safety of a compression plate wringer.

I claim:

1. In a mop comprising a holder, a compressible mopping member mounted in said holder and having opposite sides normally flaring outwardly from said holder, a frame, means mounting said frame on said holder for back and forth movement in directions transverse to said normally flared sides, wringing elements pivotally mounted on said frame on axes parallel to said flared sides and at a distance apart less than the normal width of the flared portion of said mopping member, and means for moving said frame back and forth relative to said holder, said wringing elements having surfaces parallel to said axes whose normally outwardly extending portions are spaced from said axes a distance greater than the portions of said wringing elements which normally extend inwardly toward each other, whereby actuation of said last named means pivots said wringing elements to compress said mopping member between the first named portions of said wringing elements.

2. A mop comprising a holder, a compressible mopping member mounted in said holder and having opposite sides normally flaring outwardly from said holder, a frame, wringing elements pivotally mounted on said frame on axes parallel to the opposite flared sides of said mopping member and at a distance apart less than the normal width of the flared portion of said member, and operating means interconnecting said frame and holder and actuable to effect relative reciprocation thereof in directions transverse to said normally flared sides, said wringing elements having surfaces parallel to said axes and so defining a part of each wringing element normally extending outwardly from said member as to space the surface of said part from the axis of said wringing element a distance greater than the surface of the part of said wringing element normally extending inwardly toward said member, whereby pivoting of said wringing elements upon actuation of said operating means compresses the normally flaring portion of said mop-

ping member between the said surfaces of said first named parts of said wringing elements.

3. A mop comprising a holder, a compressible mopping member mounted in said holder and having opposite sides normally flaring outwardly from said holder, a frame, wringing elements pivotally mounted on said frame on axes parallel to the opposite flared sides of said mopping member and at a distance apart less than the normal width of the flared portion of said member, and operating means interconnecting said frame and holder and actuable to effect relative reciprocation thereof in directions transverse to said normally flared sides, said wringing elements each having a projecting portion defined in part by a substantially flat surface, said flat surfaces normally extending at an angle to the direction of said reciprocation, said wringing elements pivoting to compress the normally flared portion of said mopping member between the flat surfaces of the projecting portions of said wringing elements upon actuation of said operating means.

4. A mop as defined in claim 3, and stops carried by said frame and engaged by said projections when said operating means and wringing elements are in normal position.

5. A mop comprising a holder, a compressible mopping member mounted in said holder and having opposite sides normally flaring outwardly from said holder, a frame, wringing elements pivotally mounted on said frame on axes parallel to the opposite flared sides of said mopping member and at a distance apart less than the normal width of the flared portion of said member, and operating means interconnecting said frame and holder and actuable to effect relative reciprocation thereof in directions transverse to said normally flared sides, said wringing elements each having a body portion and a projection coextensive with the length of said body portion which normally extends outwardly relative to said body portion, the body portions of said wringing elements frictionally engaging said member upon actuation of said operating means to pivot to positions with said projections compressing said flared portion of said member therebetween.

6. A mop comprising a holder, a compressible mopping member carried by said holder, and having a portion normally flaring outwardly from said holder, a frame, wringing elements rotatably mounted on said frame on axes spaced apart a fixed distance, said wringing elements being parallel to and engaging the sides of said mopping member, said wringing elements each having a flat face, and operating means actuable to reciprocate one with respect to the other of said frame and holder, said flat faces being normally positioned at an angle to the direction of said reciprocation, actuation of said operating means tilting said wringer elements to positions with said flat faces substantially parallel to the direction of said reciprocation for compressing engagement with the mopping member.

7. A mop comprising a holder, a compressible mopping member carried by said holder, a frame having a portion in spaced opposed relation to said holder, wringing elements engageable with the sides of said member and journaled in said frame on axes parallel to the sides of said member, operating means interconnecting said frame and holder and actuable to effect relative reciprocation thereof, a chambered telescoping guide extending between said frame portion and holder and bearing thereagainst adjacent its ends, and spring means in said guide to normally urge said parts to positions with said wringing elements in inoperative relation to said mopping member.

8. A mop as defined in claim 7, wherein said operating means is positioned substantially centrally of said holder and frame, and a pair of said chambered telescoping guides between said holder and frame are positioned in substantially equi-spaced relation to and on opposite sides of said operating means.

9. A mop as defined in claim 7, wherein said operating means comprises a part pivoted to said holder having a pin and slot connection with said frame, said slot extending transverse of the direction of said reciprocation.

KENNETH S. ROGERS. 45