



- (51) International Patent Classification:
A61B 17/70 (2006.01)
- (21) International Application Number:
PCT/EP2009/067208
- (22) International Filing Date:
15 December 2009 (15.12.2009)
- (25) Filing Language: English
- (26) Publication Language: English
- (30) Priority Data:
MI2008A002238 17 December 2008 (17.12.2008) IT
- (71) Applicant (for all designated States except US): **N.B.R. NEW BIOTECHNOLOGY RESEARCH** [IT/IT]; Via Nizza, 20, I-37121 Verona (IT).
- (72) Inventor; and
(71) Applicant : **CALVOSA, Giuseppe** [IT/IT]; Via Randaccio, 24, I-56123 Pisa (IT).
- (72) Inventors; and
(75) Inventors/Applicants (for US only): **CERVELLINI, Patrizio** [IT/IT]; Corso Antonio Fogazzaro, 220, I-36100 Vicenza (IT). **TENUCCI, Miria** [IT/IT]; Via Teodorico Borgognoni, 124, I-55100 Lucca (IT).
- (74) Agent: **MODIANO, Micaela**; Modiano & Partners, Via Meravigli, 16, I-20123 Milano (IT).
- (81) Designated States (unless otherwise indicated, for every kind of national protection available): AE, AG, AL, AM, AO, AT, AU, AZ, BA, BB, BG, BH, BR, BW, BY, BZ, CA, CH, CL, CN, CO, CR, CU, CZ, DE, DK, DM, DO, DZ, EC, EE, EG, ES, FI, GB, GD, GE, GH, GM, GT, HN, HR, HU, ID, IL, IN, IS, JP, KE, KG, KM, KN, KP, KR, KZ, LA, LC, LK, LR, LS, LT, LU, LY, MA, MD, ME, MG, MK, MN, MW, MX, MY, MZ, NA, NG, NI, NO, NZ, OM, PE, PG, PH, PL, PT, RO, RS, RU, SC, SD, SE, SG, SK, SL, SM, ST, SV, SY, TJ, TM, TN, TR, TT, TZ, UA, UG, US, UZ, VC, VN, ZA, ZM, ZW.
- (84) Designated States (unless otherwise indicated, for every kind of regional protection available): ARIPO (BW, GH,

[Continued on next page]

(54) Title: MODULAR VERTEBRAL STABILIZER

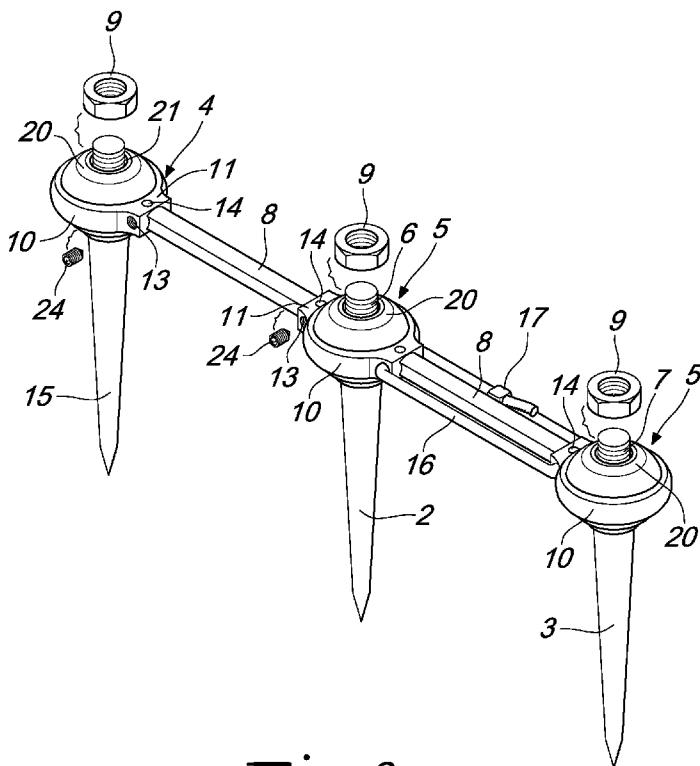

Fig. 2

(57) Abstract: A stabilizer device (1) for the spinal column, comprising first engagement means (4) and second engagement means (5), which are adapted to be connected to each other by a rod-like element (8), the first and second engagement means (4, 5) being adapted to be fitted on first and second pedicle screws (2, 3), which are adapted to be in turn inserted in two adjacent vertebrae, the first and second engagement means (4, 5) being fixable on the pedicle screws (2, 3); the first and second engagement means (4, 5) accommodate bearing means (20), which are adapted to rotate within the first and second engagement means (4, 5) and to be fitted on the pedicle screws (2, 3), in order to allow the fitting of the first and second engagement means (4, 5) on the pedicle screws (2, 3).

WO 2010/069967 A1

GM, KE, LS, MW, MZ, NA, SD, SL, SZ, TZ, UG, ZM, ZW), Eurasian (AM, AZ, BY, KG, KZ, MD, RU, TJ, TM), European (AT, BE, BG, CH, CY, CZ, DE, DK, EE, ES, FI, FR, GB, GR, HR, HU, IE, IS, IT, LT, LU, LV, MC, MK, MT, NL, NO, PL, PT, RO, SE, SI, SK, SM,

TR), OAPI (BF, BJ, CF, CG, CI, CM, GA, GN, GQ, GW, ML, MR, NE, SN, TD, TG).

Published:

— with international search report (Art. 21(3))

MODULAR VERTEBRAL STABILIZER

Technical field

The present invention relates to a modular vertebral stabilizer. More particularly, it relates to a modular vertebral stabilizer that is adapted to connect at least two adjacent vertebrae to each other by using at least two connecting elements which allow some certain limited movement to the vertebrae.

Background Art

As is known, many pathologies related to the functionality of the spinal column are treated by total or partial immobilization, particularly with a technique known as "intervertebral arthrodesis", with the aid of connection means and/or with the addition of portions of bone tissue which join such adjacent vertebrae.

Vertebral stabilization devices of the static and dynamic types are known in the art and have a screw that is adapted to be connected to a vertebra, and rigid elements or elements that have a limited mobility and have two ends which are jointly connected to the two screws connected to two adjacent vertebrae.

In particular, a dynamic stabilizing device, i.e., capable of allowing relative movement between the vertebrae, is disclosed in EP 0 669 109. This vertebral stabilizer comprises a spacing body, which is resistant to compression and is adapted to transfer forces between two screws implanted in the respective vertebrae, and a tensioning cord which is connected between the two screws described above and passes in an internal longitudinal cavity obtained in the spacing body.

However, this stabilizer has a drawback, due to the fact that it is directly assembled locally on the spinal column after inserting the screws in the vertebrae, with open surgery in a space that is close to the vertebra. Therefore, the surgical procedure that makes it possible to use such stabilization structure is highly invasive, since it is necessary to create

enough space close to the vertebra to perform the various steps of assembly, with considerable difficulty for the surgeon, who has to arrange and assemble each individual element directly on the vertebra.

Moreover, the stabilizer described above does not allow a transverse
5 connection between screws mounted on different vertebrae to transmit forces in a diagonal direction with respect to the axis of the spinal column.

Further, the tensioning cord must be threaded in the spacing body, and this requires a higher skill effort for the surgeon.

Moreover, the surgeon may need a stabilizer that has both static and
10 dynamic portions, i.e., he may have to create a hybrid stabilizer, in which the portions can be chosen by the surgeon according to the characteristics of the pathology.

Known types of stabilizers do not allow creation of a stabilizer of the hybrid type that is totally modular, i.e., capable of adapting to all the
15 configurations that the pathology of the patient may require and are decided on by the surgeon, for example rigid-dynamic-rigid, or dynamic-rigid-dynamic.

WO2007/060534, in the name of this same Applicant as the present invention, discloses a vertebral stabilizer of the dynamic modular type,
20 which is adapted to be assembled separately from the spinal column and then fitted onto the spinal column in a few seconds.

However, the known type of stabilizer device is unable to adapt to angle variations with which the pedicle screws might be fitted within the vertebrae, and therefore, if the positioning of such pedicle screws is not
25 performed, in two adjacent vertebrae, with the same angle, the surgeon encounters difficulties in mounting the stabilizer device fitted over the heads of the pedicle screws.

Disclosure of the Invention

The aim of the present invention is to provide a device for stabilizing
30 the spinal column which allows transverse connection between adjacent

vertebrae, allowing different angles between pedicle screws inserted in adjacent vertebrae.

Within this aim, an object of the present invention is to provide a stabilizer device that can be assembled separately from the spinal column and then fitted onto said spinal column with reduced invasiveness for the patient.

Another object of the present invention is to provide a spinal column stabilizer device that is modular, allowing therefore provision of a hybrid stabilizer device, i.e., a device that is static at one end and dynamic at the opposite end.

Another object of the present invention is to provide a stabilizer device that is highly reliable, relatively simple to provide and at competitive costs.

This aim and these and other objects that will become better apparent hereinafter are achieved by a stabilizer device for the spinal column, comprising a first disk-like body and a second disk-like body, which are adapted to be connected to each other by a rod-like element, said first and second disk-like bodies being adapted to be fitted on first and second pedicle screws, which are adapted to be in turn inserted in two adjacent vertebrae, said first and second disk-like bodies being fixable on said pedicle screws, characterized in that said first and second disk-like bodies accommodate bearing means, which are adapted to rotate within said first and second disk-like bodies and to be fitted on said pedicle screws, in order to allow the fitting of said first and second disk-like bodies on said pedicle screws.

Brief description of the drawings

Further characteristics and advantages of the invention will become better apparent from the following detailed description of some preferred but not exclusive embodiments of the device according to the present invention, illustrated by way of non-limiting example in the accompanying

drawings, wherein:

Figure 1 is an exploded perspective view of a stabilizer device according to the present invention;

Figure 2 is a perspective view of a second embodiment of the stabilizer device according to the present invention;

Figure 3 is a perspective view of the stabilizer device of Figure 1 in the assembled condition.

Ways of carrying out the Invention

With reference to the figures, a stabilizer device according to the present invention, generally designated by the reference numeral 1, comprises first and second means for engaging a first pedicle screw 2 and a second pedicle screw 3, which are adapted to be inserted in two adjacent vertebrae to be connected to each other for mutual stabilization.

The pedicle screws are conveniently headless and cannulated, so that they can be screwed into the vertebrae.

First engagement means, designated by the reference numeral 4, and second engagement means, designated by the reference numeral 5, are adapted to be fitted from above on a threaded portion 6 and 7 respectively on the first pedicle screw 2 and on the second pedicle screw 3.

The first and second engagement means 4 and 5 are connected to each other by a rod-like element 8, of the bar type, which can be made of a rigid material, such as for example titanium, or of softer material, such as for example polyurethane, so as to give flexibility to the rod-like element.

Conveniently, there are locking means 9, constituted for example by nuts, for locking engagement means 4 and 5 on the threaded portions 6 and 7 of the first and second pedicle screws described earlier.

Conveniently, the engagement means 4 and 5 comprise a substantially circular body 10, which is provided with at least one protruding portion 11, which is adapted to form a seat 12 for the engagement of the rod-like element 8. The seat 12 formed in the protruding portion 11 is conveniently

shaped so as to be complementary with respect to the shape of the rod-like element 8.

Conveniently, the protruding portion 11 of the circular body 10 is provided with at least one hole 13, which allows either the insertion of a fastening cord, as defined hereinafter, or of a locking grub, as also described hereinafter.

Conveniently, the protruding portion 11 can be provided with a second hole arranged on its upper face, i.e., the face designed to be arranged parallel to the spinal column, and is adapted to accommodate a fixing grub, which can allow further fixing of the cord described hereinafter.

The circular or disk-like element 10 can be provided with a pair of protruding portions 11, which are diametrically opposite, as shown in Figure 2, so as to create an element that is adapted to allow the connection of two rod-like elements, on either side, so as to mutually mate three pedicle screws inserted in three adjacent vertebrae.

In Figure 2, the third pedicle screw, in addition to the first and second pedicle screws 2 and 3, is designated by the reference numeral 15. Such pedicle screws, despite having different reference numerals that designate them, are mutually identical.

In Figure 2 there is also shown the presence of the cord cited above, designated by the reference numeral 16 and made for example of methyl methacrylate, which enters the holes 13 of the circular or disk-like elements 10 and lies in a closed circuit around the rod-like element 8, which in this case is made of elastic material.

Conveniently, the two ends of the cord 16, adapted to be mutually coupled so as to provide a cord that is closed in a loop around the rod-like element 8, are provided with respective tensioning means 17, which are adapted to allow tensioning of the cord 16.

Conveniently, the tensioning means 17 can be provided for example with one end of the cord which is provided with a set of teeth and the

opposite end which is provided with a receptacle, like a hose clamp.

In this manner, the surgeon can perform, separately from the spinal column, a fastening of the cord 16 around the rod-like element 8 and then, once the stabilizer device has been assembled, said device can be fitted on
5 the pedicle screws that are already accommodated in the holes provided in the vertebrae to be coupled in a stabilized manner.

Conveniently, the circular or disk-like body 10 is provided internally with a circular opening which accommodates bearing means 20, which are adapted to rotate within the circular or disk-like body 10, so as to allow the
10 arrangement of the engagement means 4 at different angles between one screw and the screw that is adjacent to it, thus also allowing a slight positioning error of the pedicle screws inserted in the vertebrae that are to be mutually coupled.

Conveniently, the bearing 20 is provided with a central hole 21,
15 which is adapted to allow the insertion of the threaded portion 6 of the pedicle screw 2 or of the threaded portion 7 of the pedicle screw 3.

Conveniently, the rod-like element 8 has a circular cross-section with a pair of lateral recesses 22 and 23 which are adapted to accommodate the cord 16 when it is fastened around the rod-like element 8.

20 Figure 2 shows threaded grubs 24, which are inserted in the protruding portions 11 of the disk-like bodies 10 so as to fasten the rod-like element 8.

Figure 2 is a view of the provision of a hybrid stabilizer device, i.e., a partly dynamic and partly static stabilizer device, which is obtained by
25 coupling three pedicle screws to each other with a first rod-like element 8 of the rigid type and a second rod-like element 8 of the elastic type, with which the cord 16 fastened around the rod-like element 8 is associated.

The bearing element 20 accommodated within the hole formed in the disk-like body 10 is adapted to rotate within said hole, so as to behave like a
30 sort of ball that can rotate in all directions within the hole of the disk-like

body 10.

In practice it has been found that the stabilizer device according to the present invention fully achieves the intended aim and objects, since it allows to be assembled away from the spinal column, allows to adapt to different
5 implantation angles of the pedicle screws within the vertebrae, and allows to provide hybrid structures with rigid portions and elastic portions.

Moreover, this modular system allows to change, whenever necessary, only the disk-like bodies and the bar with a different bar or rod, leaving the screws inserted in the pedicles, with great advantage for the
10 patient and for the surgeon.

The stabilizer device thus conceived is susceptible of numerous modifications and variations, all of which are within the scope of the appended claims; all the details may further be replaced with other technically equivalent elements.

15 In practice, the materials used, as well as the contingent shapes and dimensions, may be any according to requirements and to the state of the art.

The disclosures in Italian Patent Application No. MI2008A002238 from which this application claims priority are incorporated herein by
20 reference.

Where technical features mentioned in any claim are followed by reference signs, those reference signs have been included for the sole purpose of increasing the intelligibility of the claims and accordingly, such reference signs do not have any limiting effect on the interpretation of each
25 element identified by way of example by such reference signs.

CLAIMS

1. A stabilizer device for the spinal column, comprising first engagement means and second engagement means, which are adapted to be connected to each other by a rod-like element, said first and second
5 engagement means being adapted to be fitted on first and second pedicle screws, which are adapted to be in turn inserted in two adjacent vertebrae, said first and second engagement means being fixable on said pedicle screws, characterized in that said first and second engagement means accommodate bearing means, which are adapted to rotate within said first
10 and second engagement means and to be fitted on said pedicle screws, in order to allow the fitting of said first and second engagement means on said pedicle screws.

2. The device according to claim 1, characterized in that said first and second engagement means are connected to each other through a rigid rod-
15 like element.

3. The device according to claim 1, characterized in that said first and second engagement means are connected to each other through a flexible rod-like element.

4. The device according to one or more of the preceding claims, characterized in that said first and second engagement means comprise disk-
20 like bodies provided with at least one protruding portion that is adapted to accommodate said rod-like element.

5. The device according to one or more of the preceding claims, characterized in that said pedicle screws are headless screws.

25 6. The device according to one or more of the preceding claims, characterized in that at least one of said first and second disk-like elements is provided with a second protruding portion, which is arranged diametrically opposite the first protruding portion and is adapted to accommodate a further rod-like element.

30 7. The device according to one or more of the preceding claims,

characterized in that said first and second disk-like elements are coupled to each other by said rod-like element and by a cord that is adapted to be fastened around said rod-like element that passes within the respective protruding portions of said first and second disk-like elements.

5 8. The device according to one or more of the preceding claims, characterized in that said flexible rod-like element is provided with two mutually opposite lateral recesses, which are adapted to accommodate said cord suitable to be fastened around said rod-like element.

9. The device according to one or more of the preceding claims,
10 characterized in that said cord is provided, at one end, with a plurality of teeth for fastening within accommodation means provided at the opposite end, said accommodation means being adapted to allow the fastening within them of said end provided with teeth, so as to fasten said cord around said rod-like element.

15 10. The device according to one or more of the preceding claims, characterized in that said protruding portions of said first and second disk-like elements are provided with at least one hole which is adapted to allow either the passage of said cord or the insertion of a threaded grub which is adapted to allow the locking of said rod-like element within said protruding
20 portions.

11. An element for fixing to a pedicle screw, comprising a disk-like body adapted to be fitted on the head of said pedicle screw, characterized in that said disk-like body accommodates bearing means which are adapted to rotate within said body in all directions, in order to allow the fitting of said
25 body on said pedicle screw.

12. The fixing element according to claim 11, characterized in that said body is provided with at least one protruding portion which has a receptacle for accommodating a rod-like element adapted to allow connection to a further fixing body.

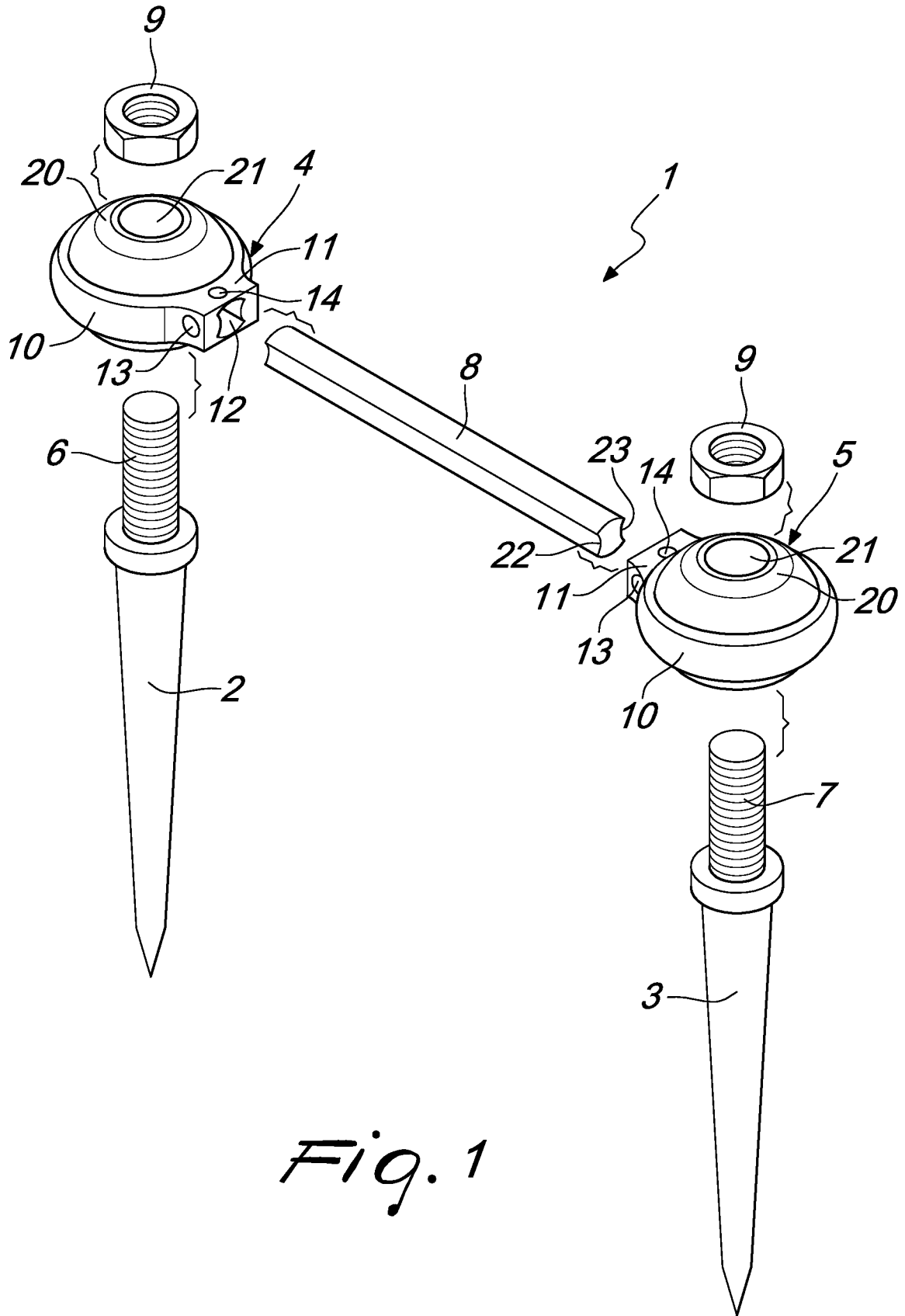

Fig. 1

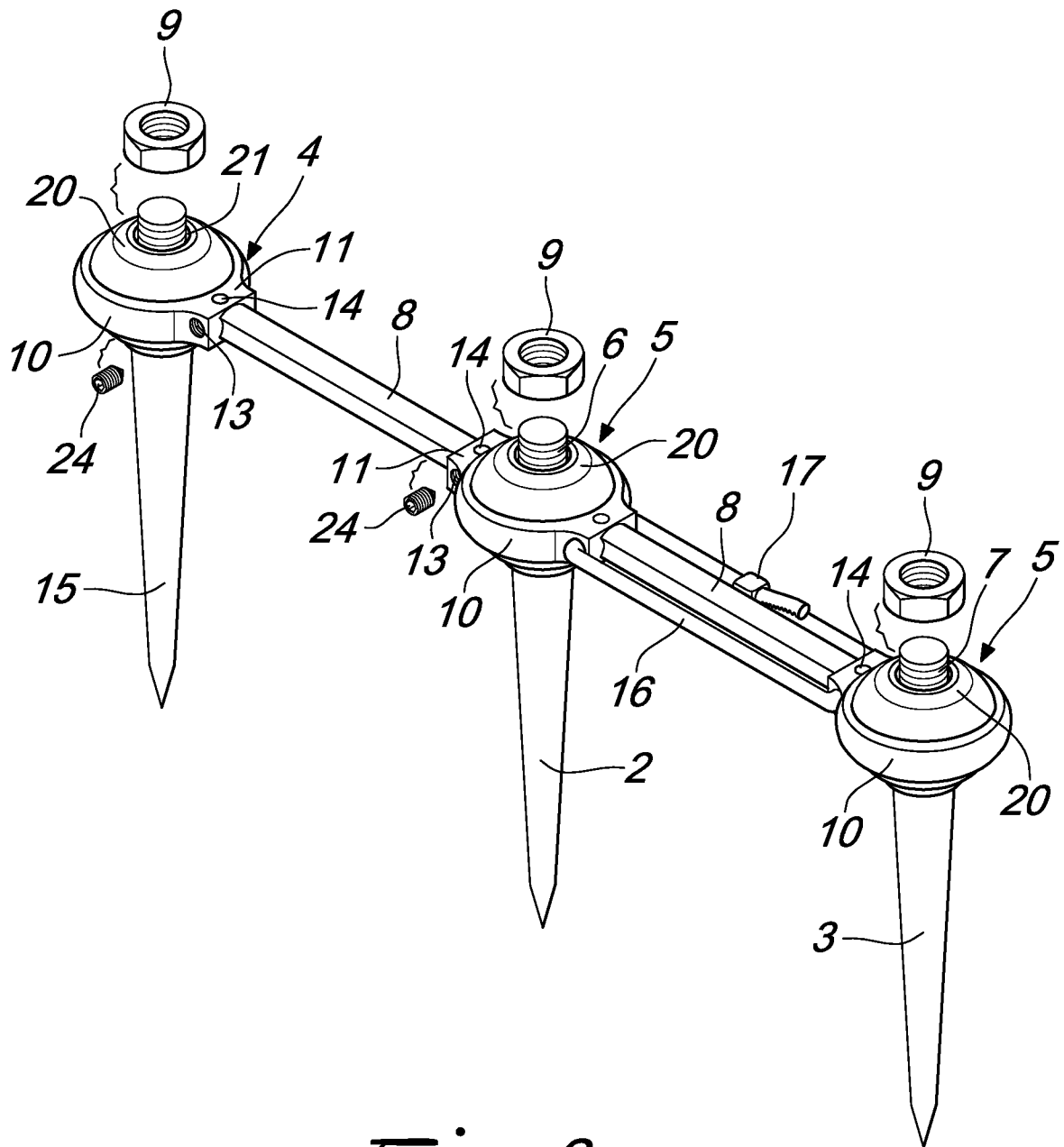

Fig. 2

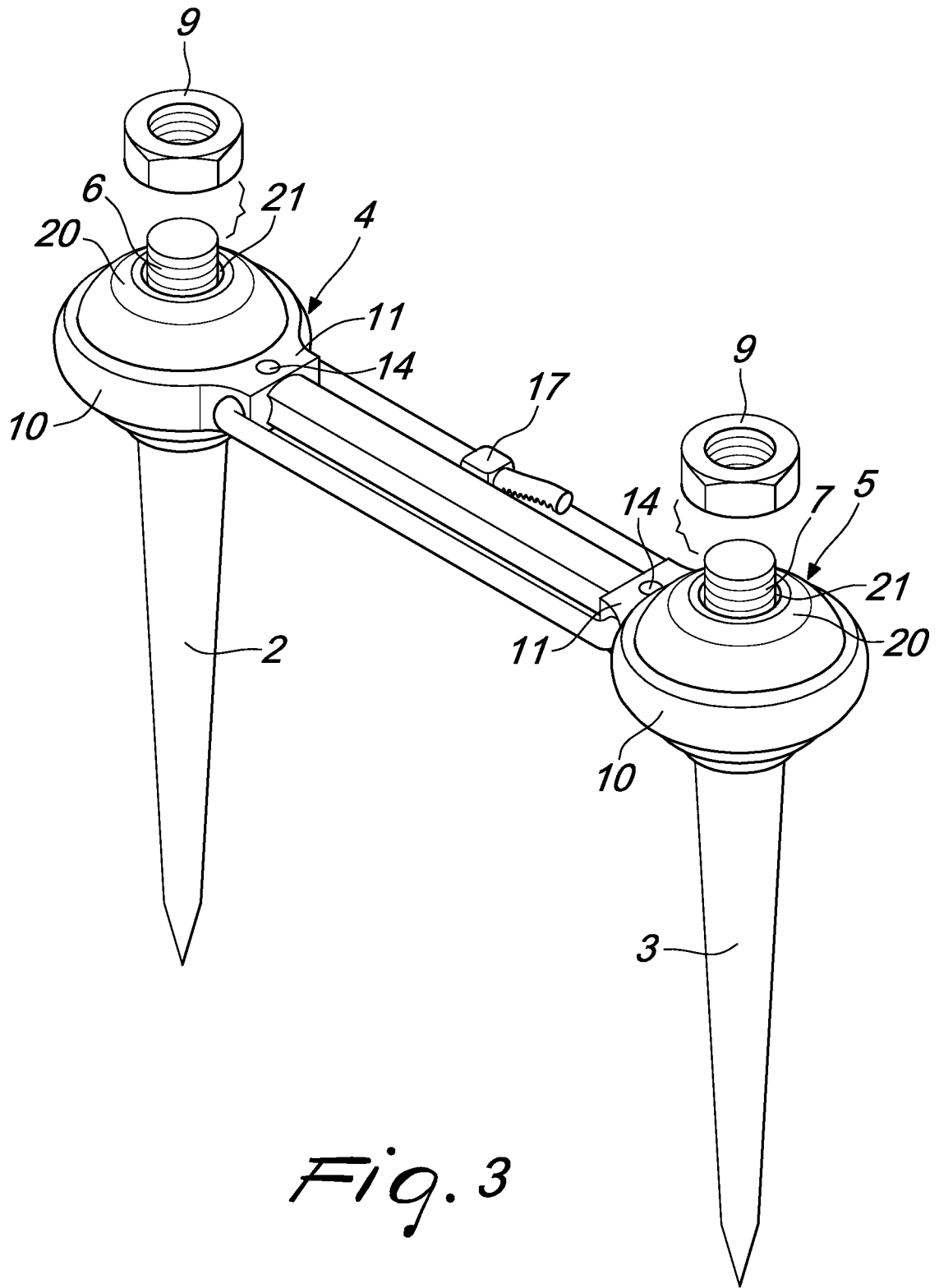

Fig. 3

INTERNATIONAL SEARCH REPORT

International application No
PCT/EP2009/067208

| | | | | |
|---|---|--|---|---|
| A. CLASSIFICATION OF SUBJECT MATTER INV. A61B17/70 | | | | |
| According to International Patent Classification (IPC) or to both national classification and IPC | | | | |
| B. FIELDS SEARCHED | | | | |
| Minimum documentation searched (classification system followed by classification symbols) A61B | | | | |
| Documentation searched other than minimum documentation to the extent that such documents are included in the fields searched | | | | |
| Electronic data base consulted during the international search (name of data base and, where practical, search terms used) EPO-Internal | | | | |
| C. DOCUMENTS CONSIDERED TO BE RELEVANT | | | | |
| Category* | Citation of document, with indication, where appropriate, of the relevant passages | Relevant to claim No. | | |
| X | US 2005/143737 A1 (PAFFORD JOHN [US] ET AL) 30 June 2005 (2005-06-30) paragraph [0034] - paragraph [0035]; figure 1 paragraph [0037]; figure 2 paragraph [0042] | 1-12 | | |
| X | US 2008/161853 A1 (ARNOLD BENJAMIN [US] ET AL) 3 July 2008 (2008-07-03) figure 1 paragraph [0070]; figure 14 | 1-3,11 | | |
| X | US 2007/043356 A1 (TIMM JENS P [US] ET AL) 22 February 2007 (2007-02-22) figures 8,9,11,19 | 1-12 | | |
| | ----- -/-- | | | |
| <input checked="" type="checkbox"/> Further documents are listed in the continuation of Box C. <input checked="" type="checkbox"/> See patent family annex. | | | | |
| * Special categories of cited documents : <table style="width:100%; border:none;"> <tr> <td style="width:50%; vertical-align: top;"> "A" document defining the general state of the art which is not considered to be of particular relevance "E" earlier document but published on or after the international filing date "L" document which may throw doubts on priority claim(s) or which is cited to establish the publication date of another citation or other special reason (as specified) "O" document referring to an oral disclosure, use, exhibition or other means "P" document published prior to the international filing date but later than the priority date claimed </td> <td style="width:50%; vertical-align: top;"> "T" later document published after the international filing date or priority date and not in conflict with the application but cited to understand the principle or theory underlying the invention "X" document of particular relevance; the claimed invention cannot be considered novel or cannot be considered to involve an inventive step when the document is taken alone "Y" document of particular relevance; the claimed invention cannot be considered to involve an inventive step when the document is combined with one or more other such documents, such combination being obvious to a person skilled in the art. "&" document member of the same patent family </td> </tr> </table> | | | "A" document defining the general state of the art which is not considered to be of particular relevance "E" earlier document but published on or after the international filing date "L" document which may throw doubts on priority claim(s) or which is cited to establish the publication date of another citation or other special reason (as specified) "O" document referring to an oral disclosure, use, exhibition or other means "P" document published prior to the international filing date but later than the priority date claimed | "T" later document published after the international filing date or priority date and not in conflict with the application but cited to understand the principle or theory underlying the invention "X" document of particular relevance; the claimed invention cannot be considered novel or cannot be considered to involve an inventive step when the document is taken alone "Y" document of particular relevance; the claimed invention cannot be considered to involve an inventive step when the document is combined with one or more other such documents, such combination being obvious to a person skilled in the art. "&" document member of the same patent family |
| "A" document defining the general state of the art which is not considered to be of particular relevance "E" earlier document but published on or after the international filing date "L" document which may throw doubts on priority claim(s) or which is cited to establish the publication date of another citation or other special reason (as specified) "O" document referring to an oral disclosure, use, exhibition or other means "P" document published prior to the international filing date but later than the priority date claimed | "T" later document published after the international filing date or priority date and not in conflict with the application but cited to understand the principle or theory underlying the invention "X" document of particular relevance; the claimed invention cannot be considered novel or cannot be considered to involve an inventive step when the document is taken alone "Y" document of particular relevance; the claimed invention cannot be considered to involve an inventive step when the document is combined with one or more other such documents, such combination being obvious to a person skilled in the art. "&" document member of the same patent family | | | |
| Date of the actual completion of the international search | | Date of mailing of the international search report | | |
| 10 February 2010 | | 19/02/2010 | | |
| Name and mailing address of the ISA/ European Patent Office, P.B. 5818 Patentlaan 2 NL - 2280 HV Rijswijk Tel. (+31-70) 340-2040, Fax: (+31-70) 340-3016 | | Authorized officer Ducreau, Francis | | |

INTERNATIONAL SEARCH REPORT

International application No
PCT/EP2009/067208

C(Continuation). DOCUMENTS CONSIDERED TO BE RELEVANT

| Category* | Citation of document, with indication, where appropriate, of the relevant passages | Relevant to claim No. |
|-----------|---|-----------------------|
| X | US 2005/154390 A1 (BIEDERMANN LUTZ [DE] ET AL) 14 July 2005 (2005-07-14) figure 18b ----- | 1-3, 11 |
| A | WO 2007/060534 A (CALVOSA GIUSEPPE [IT]; TENUCCI MIRIA [IT]) 31 May 2007 (2007-05-31) cited in the application the whole document ----- | 1 |

INTERNATIONAL SEARCH REPORT

Information on patent family members

International application No

PCT/EP2009/067208

| Patent document cited in search report | Publication date | Patent family member(s) | Publication date |
|--|------------------|--------------------------------------|--------------------------|
| US 2005143737 A1 | 30-06-2005 | US 2009254123 A1 WO 2005065375 A2 | 08-10-2009 21-07-2005 |
| US 2008161853 A1 | 03-07-2008 | WO 2008085369 A1 | 17-07-2008 |
| US 2007043356 A1 | 22-02-2007 | AT 445370 T EP 1747760 A1 | 15-10-2009 31-01-2007 |
| US 2005154390 A1 | 14-07-2005 | WO 2005044123 A1 | 19-05-2005 |
| WO 2007060534 A | 31-05-2007 | EP 1954205 A2 US 2008262546 A1 | 13-08-2008 23-10-2008 |