

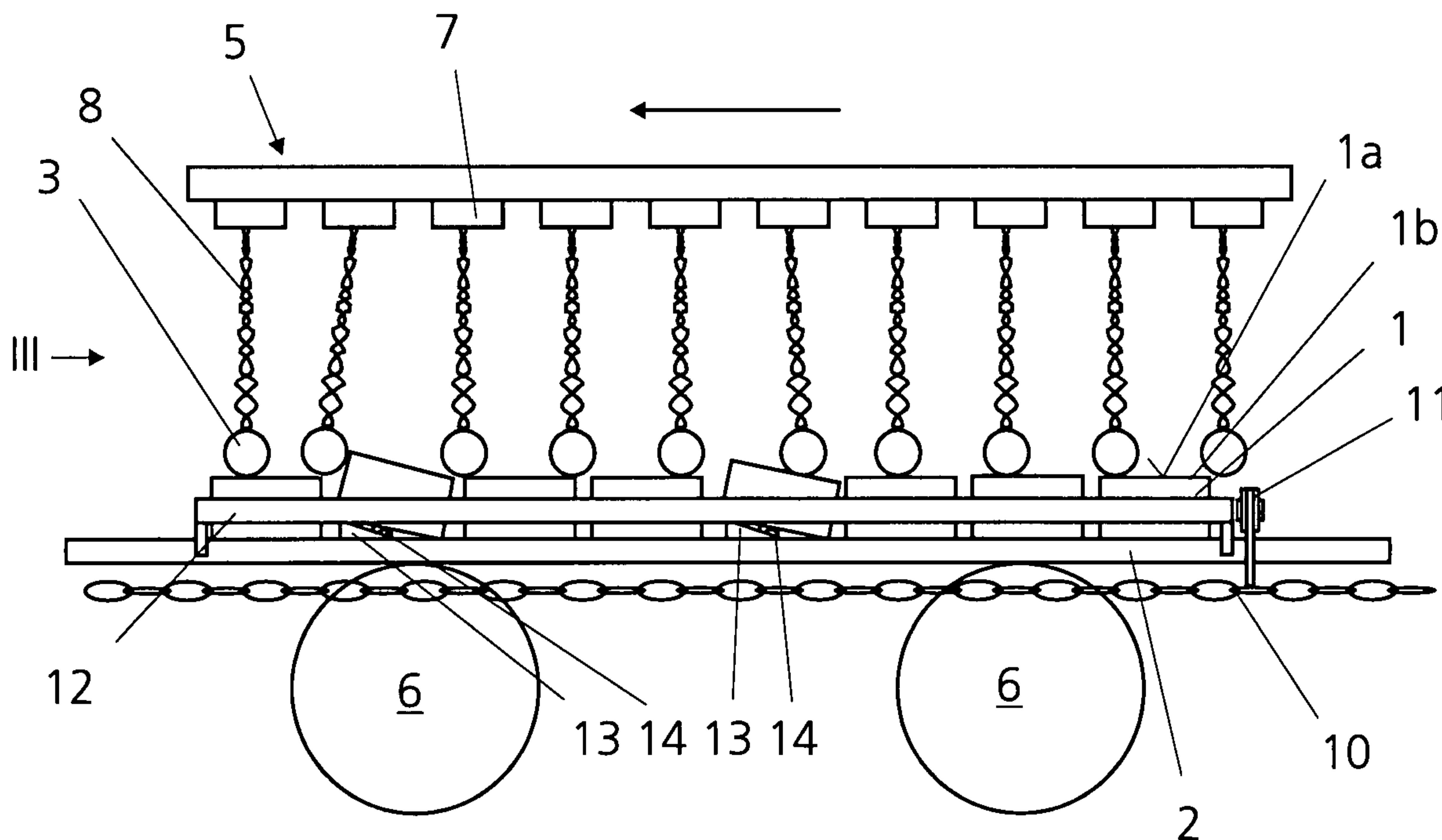

(86) Date de dépôt PCT/PCT Filing Date: 2006/05/09
 (87) Date publication PCT/PCT Publication Date: 2006/12/28
 (45) Date de délivrance/Issue Date: 2011/01/04
 (85) Entrée phase nationale/National Entry: 2007/12/19
 (86) N° demande PCT/PCT Application No.: EP 2006/004292
 (87) N° publication PCT/PCT Publication No.: 2006/136235
 (30) Priorités/Priorities: 2005/06/22 (DE10 2005 029 212.7);
 2005/11/23 (DE10 2005 056 163.2)

(51) Cl.Int./Int.Cl. *B28B 11/08* (2006.01),
B28D 1/30 (2006.01)
 (72) Inventeurs/Inventors:
 GEBHART, HANS, DE;
 STAEHLE, MANFRED, DE;
 WERNER, ROLAND, DE
 (73) Propriétaire/Owner:
 BAUSTOFFWERKE GEBHART & SOEHNE GMBH &
 CO. KG, DE
 (74) Agent: DENNISON ASSOCIATES

(54) Titre : PROCÉDE ET DISPOSITIF DE VIEILLISSEMENT ARTIFICIEL DE PIERRES
 (54) Title: METHOD AND APPARATUS FOR THE ARTIFICIAL AGING OF BLOCKS



(57) Abrégé/Abstract:

A device for artificially aging stones (1), particularly concrete stones, clinker bricks and natural stones comprises a support (2) on which the stones can be placed so that their surfaces (1a) to be treated and the adjoining edges (1b) are exposed. Striking bodies (3) that are, in essence, freely moving are used for treating the surfaces and the adjoining edges of the stones. A vibrating device (6) moves the stones and the striking bodies relative to one another in such a manner that the striking bodies act upon the surfaces and the exposed edges of the stones. The striking bodies are displaceably attached to a holding device (5) in such a manner that the striking bodies can move freely within a defined area (4) of the surface of the stones.

(12) NACH DEM VERTRAG ÜBER DIE INTERNATIONALE ZUSAMMENARBEIT AUF DEM GEBIET DES PATENTWESENS (PCT) VERÖFFENTLICHTE INTERNATIONALE ANMELDUNG

(19) Weltorganisation für geistiges Eigentum
Internationales Büro(43) Internationales Veröffentlichungsdatum
28. Dezember 2006 (28.12.2006)

PCT

(10) Internationale Veröffentlichungsnummer
WO 2006/136235 A3

(51) Internationale Patentklassifikation:

B28B 11/08 (2006.01) **B28D 1/30** (2006.01)

(21) Internationales Aktenzeichen: PCT/EP2006/004292

(22) Internationales Anmeldedatum:

9. Mai 2006 (09.05.2006)

(25) Einreichungssprache:

Deutsch

(26) Veröffentlichungssprache:

Deutsch

(30) Angaben zur Priorität:

10 2005 029 212.7 22. Juni 2005 (22.06.2005) DE

10 2005 056 163.2

23. November 2005 (23.11.2005) DE

(71) Anmelder (für alle Bestimmungsstaaten mit Ausnahme von US): **BAUSTOFFWERKE GEBHART & SÖHNE GMBH & CO. KG** [DE/DE]; Hochstrasse 2, 88317 Aichstetten (DE).

(72) Erfinder; und

(75) Erfinder/Anmelder (nur für US): **GEBHART, Hans**[DE/DE]; Im Unterdorf 7, 87700 Memmingen (DE). **STAEHLE, Manfred** [DE/DE]; Alte Markt Str. 15, 88299 Leutkirch (DE). **WERNER, Roland** [DE/DE]; Hart 46, 88299 Leutkirch (DE).(74) Anwalt: **LORENZ & KOLLEGEN**; Alte Ulmer Str. 2, 89522 Heidenheim (DE).

(81) Bestimmungsstaaten (soweit nicht anders angegeben, für jede verfügbare nationale Schutzrechtsart): AE, AG, AL, AM, AT, AU, AZ, BA, BB, BG, BR, BW, BY, BZ, CA, CH, CN, CO, CR, CU, CZ, DE, DK, DM, DZ, EC, EE, EG, ES, FI, GB, GD, GE, GH, GM, HR, HU, ID, IL, IN, IS, JP, KE, KG, KM, KN, KP, KR, KZ, LC, LK, LR, LS, LT, LU, LV, LY, MA, MD, MG, MK, MN, MW, MX, MZ, NA, NG, NI, NO, NZ, OM, PG, PH, PL, PT, RO, RU, SC, SD, SE, SG, SK, SL, SM, SY, TJ, TM, TN, TR, TT, TZ, UA, UG, US, UZ, VC, VN, YU, ZA, ZM, ZW.

(84) Bestimmungsstaaten (soweit nicht anders angegeben, für jede verfügbare regionale Schutzrechtsart): ARIPO (BW,

[Fortsetzung auf der nächsten Seite]

(54) Title: METHOD AND DEVICE FOR ARTIFICIALLY AGING STONES

(54) Bezeichnung: VERFAHREN UND VORRICHTUNG ZUM KÜNSTLICHEN ALTERN VON STEINEN

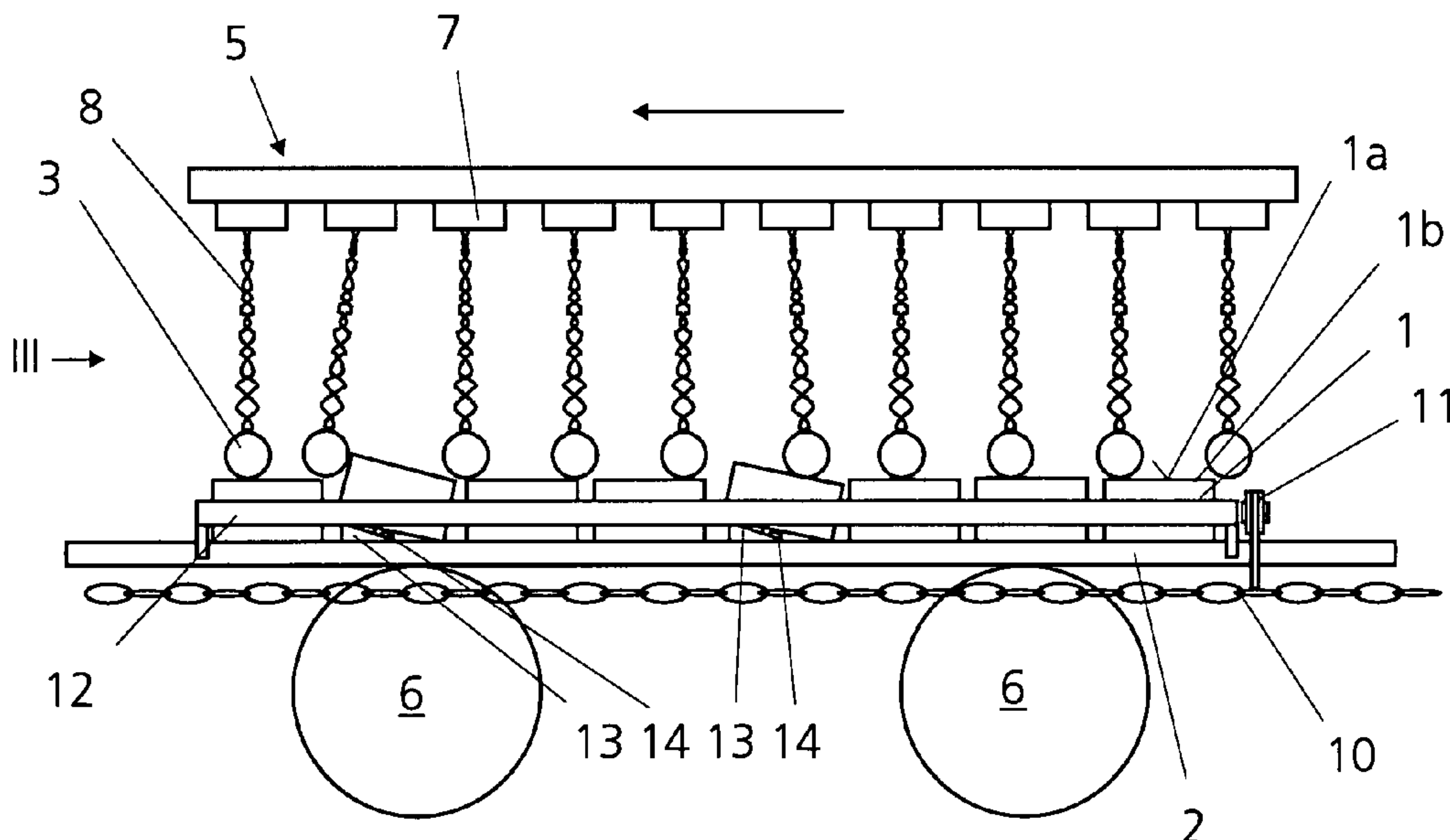

(57) Abstract: A device for artificially aging stones (1), particularly concrete stones, clinker bricks and natural stones comprises a support (2) on which the stones can be placed so that their surfaces (1a) to be treated and the adjoining edges (1b) are exposed. Striking bodies (3) that are, in essence, freely moving are used for treating the surfaces and the adjoining edges of the stones. A vibrating device (6) moves the stones and the striking bodies relative to one another in such a manner that the striking bodies act upon the surfaces and the exposed edges of the stones. The striking bodies are displaceably attached to a holding device (5) in such a manner that the striking bodies can move freely within a defined area (4) of the surface of the stones.

[Fortsetzung auf der nächsten Seite]

WO 2006/136235 A3

GH, GM, KE, LS, MW, MZ, NA, SD, SL, SZ, TZ, UG, ZM, ZW), eurasisches (AM, AZ, BY, KG, KZ, MD, RU, TJ, TM), europäisches (AT, BE, BG, CH, CY, CZ, DE, DK, EE, ES, FI, FR, GB, GR, HU, IE, IS, IT, LT, LU, LV, MC, NL, PL, PT, RO, SE, SI, SK, TR), OAPI (BF, BJ, CF, CG, CI, CM, GA, GN, GQ, GW, ML, MR, NE, SN, TD, TG).

— *hinsichtlich der Berechtigung des Anmelders, die Priorität einer früheren Anmeldung zu beanspruchen (Regel 4.17 Ziffer iii)*

Veröffentlicht:

— *mit internationalem Recherchenbericht*

(88) Veröffentlichungsdatum des internationalen**Recherchenberichts:**

19. April 2007

Erklärungen gemäß Regel 4.17:

- *hinsichtlich der Identität des Erfinders (Regel 4.17 Ziffer i)*
- *hinsichtlich der Berechtigung des Anmelders, ein Patent zu beantragen und zu erhalten (Regel 4.17 Ziffer ii)*

Zur Erklärung der Zweibuchstaben-Codes und der anderen Abkürzungen wird auf die Erklärungen ("Guidance Notes on Codes and Abbreviations") am Anfang jeder regulären Ausgabe der PCT-Gazette verwiesen.

(57) Zusammenfassung: Eine Vorrichtung zum künstlichen Altern von Steinen (1), insbesondere von Betonsteinen, Ziegelklinkern und Natursteinen weist eine Unterlage (2) auf, auf die die Steine derart auflegbar sind, dass deren zu bearbeitende Oberflächen (1a) und die angrenzenden Kanten (1b) frei liegen. Zur Bearbeitung der Oberflächen und der angrenzenden Kanten der Steine werden im wesentlichen frei bewegliche Schlagkörper (3) eingesetzt. Eine Vibrationseinrichtung (6) bringt die Steine und die Schlagkörper zueinander derart in Bewegung, dass die Schlagkörper auf die Oberflächen und die freiliegenden Kanten der Steine einwirken. Die Schlagkörper sind dabei derart beweglich an einer Halterungseinrichtung (5) befestigt, dass die Schlagkörper innerhalb eines definierten Bereichs (4) der Oberfläche der Steine frei beweglich sind.

Method and apparatus for the artificial aging of blocks

The invention relates to an apparatus for the
5 artificial aging of blocks, in particular concrete
blocks, clinker bricks and natural stone blocks,
according to the preamble of claim 1. The present
invention also relates to a method for the artificial
aging of blocks according to the preamble of claim 43.

10

An apparatus of the generic type for aging has been
disclosed by DE 20 2004 020 206.9.

Blocks, for example surfacing elements, facade
15 elements, sand-lime blocks, concrete blocks, bricks or
clinker bricks, natural stone blocks and the like,
irrespective of their material condition, are often
subjected to a subsequent treatment in order to lose
their artificial appearance.

20

Freshly produced, set concrete blocks, in particular
concrete paving blocks, are subjected to such a
subsequent treatment especially frequently, in the
course of which the surfaces and/or the edges are
25 struck or broken in order to adapt the appearance to
natural stone in this way. To this end, a relatively
large number of concrete blocks are put into a rotary
drum and "rumbled" there, the surfaces and edges of the
blocks striking one another and the blocks thus treated
30 leaving the drum in an "aged" state. Such an apparatus
has been disclosed by DE-A 29 22 393.

During the treatment of the concrete blocks in a rotary
drum, surfaces and edges which, for example when using
35 the aged blocks, are not visible at all in a paving are
also treated. To this extent, energy and time are
needlessly wasted. Furthermore, it is necessary to put
the treated concrete blocks leaving the rotary drum
onto a pallet for dispatching in a regular arrangement,

WO2006/136235

- 2 -

PCT/EP2006/004292

the amount of work and time which this involves being disproportionately high.

5 Sorting installations for sorting the blocks are known from the prior art, these sorting installations accordingly orienting the blocks and arranging them in a pallet form. Such sorting installations involve high procurement and operating costs and also take up a corresponding amount of space.

10

DE 36 21 276 C2 discloses a method in which concrete blocks are put onto a platelike base in a single layer in a regular arrangement. The exposed surfaces and the adjoining exposed edges or essentially only the edges
15 of the concrete blocks are then struck irregularly by means of a vibrating knocking or striking device.

Due to this method, a subsequent sorting device can be dispensed with, since the production layer is not
20 changed. Before the treatment by the knocking or striking devices, the blocks are pushed together and oriented on the platelike base, so that the blocks fit closely against one another and there is no longer any intermediate spaces between them. The striking tools of
25 the striking device are arranged on a movable carriage which guides said striking tools across the surfaces of the blocks, so that the free surfaces of the blocks and those edges of the blocks lying at the top are struck by the striking tools.

30

A disadvantage with this method, however, is that the blocks aged in this way look artificially treated and not naturally aged. The use of the method of the generic publication does not result in ideal breaking
35 of the edges of the blocks as is obtained by the rumbling of the blocks in a rotary drum.

Disclosed by EP 0 860 258 B2 is an apparatus and a method in which the blocks are arranged in one or two

layers, preferably in their production layer, between two elements, preferably plates. In this case, the bottom plate, on which the concrete blocks rest, is in interaction with a vibrating device. The blocks are set
5 in motion by the vibrating device, so that they move back and forth between the plates. In the process, the blocks strike one another and also strike the top and the bottom plate, as a result of which the edges on the top side and the underside are broken. In addition, the
10 top sides and the undersides of the blocks are struck by the respectively assigned plates. The vertical side edges of the concrete blocks and the side faces are broken or struck by the respectively adjoining concrete blocks.

15

It has been found in tests that the breaking of the edges is all the poorer, the larger the block to be aged is. This results from the fact that the striking angle becomes all the smaller, the larger the block put
20 between the plates is. The small striking angle results in unfavorable breaking of the edges.

As with the aging method by means of the rotary drum, there is the disadvantage in this case that surfaces
25 and edges of the blocks are treated which are possibly not visible at all, as a result of which energy and time are needlessly wasted. In addition, the requisite treatment time, in particular in the case of set concrete blocks, is long and the breaking of the edges
30 is not ideal.

The generic publication DE 20 2004 020 206.9 discloses an apparatus for the artificial aging of blocks in which the blocks - preferably in their production layer
35 - are placed on a base, so that the surfaces to be treated and the adjoining edges of the blocks are exposed. By means of a magnet, freely movable striking bodies (of metal) are then applied to the surface to be treated. The base on which the blocks rest is set in

WH-13287CA
SN 2,612,884

- 4 -

vibration by means of a vibrating device. The blocks
and the striking bodies are therefore set in motion
5 relative to one another in such a way that the striking
bodies act on the surfaces and the exposed edges of the
blocks.

The apparatus disclosed by DE 20 2004 020 206.9 enables
10 rapid and effective aging of the top side of the blocks
and the adjoining, exposed edges. The striking bodies
randomly hit the surface of the blocks and therefore
strike the latter irregularly, so that an optical
effect is produced which corresponds to that of a
15 naturally aged block.

According to the aging process, the metallic striking
bodies are lifted from the surface of the blocks again
by the magnet - by the latter being brought close to
20 the blocks. The block layer can be removed and a new
block layer can be fed. It is a disadvantage that the
magnet to be used involves high costs. A further
disadvantage is that downtimes occur due to the
striking bodies being put down and picked up again by
25 the magnet, and these downtimes lead to longer cycle
times.

The apparatus and method of the present invention
provides a cost-effective and a rapid aging of blocks.

Owing to the fact that the striking bodies are movably fastened, but this fastening allows a movement of the striking bodies within a defined region of the surface of the blocks, this achieves the effect that, firstly, surfaces or the adjoining edges of the blocks continue to be struck irregularly and thus an optical effect is produced which corresponds to that of a naturally aged block, and, secondly, a magnet for putting down the striking bodies and picking them up again from the surface can be dispensed with. By the initiation of vibrations, for example caused by a vibrating table which is arranged under the blocks, the blocks and the striking bodies are set in motion relative to one another in the manner as described in the generic publication, so that the striking bodies act on the surfaces and the adjoining edges of the blocks.

The solution according to the invention permits a plurality of variants for setting down the striking bodies and for removing them from the surfaces of the blocks and thus makes it possible to dispense with a hitherto required magnet in several ways. For example, in one embodiment, provision may be made for the retaining device on which the striking bodies are movably fastened to perform a lifting movement in order thus to be able to lift the striking bodies from the surface of the blocks or to feed them to said surface. The lifting of the striking bodies from an aged layer of blocks and the placing of the striking bodies again on a new layer of blocks to be aged can be carried out very quickly in this manner, so that short cycle times can be maintained. The downtimes are markedly reduced compared with the prior art.

35

As the inventor has recognized, a special advantage of the solution according to the invention consists in the fact that lifting the striking bodies and setting them down again can be completely dispensed with. This is

because the movable fastening or suspension of the striking bodies enables the apparatus according to the invention to be designed with a conveying device, for example in the form of a push rod or a conveying band, which pushes the blocks to be aged continuously or discontinuously through below the movably fastened striking bodies. The expression "continuous aging" also refers to an interval during which the blocks are pushed through below the striking bodies with brief interruptions of, for example, 5 seconds. In the process, the striking bodies - excited in a conventional manner by the initiated vibrations - act on, so as to age, the blocks. As already described, the movable and flexible fastening ensures that firstly the blocks are struck unevenly and that secondly the striking bodies can be prevented from traveling along with the blocks. The striking bodies in each case age the blocks which are located within the defined region available to them.

20

The defined region may be selected, for example, as a function of the number of striking bodies, the number of blocks and the speed of passage.

25 It has been found in this case that just a relatively small region within which the striking bodies are movable on the surface of the blocks is sufficient. This avoids a situation in which the striking bodies (on account of excessive mobility) can penetrate into the intermediate space between two blocks and possibly jam there.

35 According to the invention, provision may be made for the striking bodies to be arranged unevenly or irregularly on a retaining device, arranged transversely to the feed direction, both in the feed direction and transversely thereto, so that the blocks are not aged evenly.

Furthermore, according to the invention, provision may be made for the striking bodies to be arranged in a plurality of rows transversely to the feed direction of the blocks in such way that the rows of striking bodies in each case span the blocks conveyed through. The aging effect may in this case be varied by the number of rows of striking bodies below which the blocks have to pass through under the striking action of the striking bodies. Furthermore, the intensity of the aging is determined by the speed of passage and by the initiated vibrations.

Due to the selection of a suitable number of rows with striking bodies, the apparatus according to the invention can be integrated in the continuous process for producing blocks in a simple manner without this leading to a reduction in the cycle time. The blocks can pass through the apparatus of the generic type at the desired speed, the desired aging effect being achieved by the number of rows of striking bodies. The striking bodies of a row may in each case preferably be arranged offset from an upstream or downstream row of striking bodies, so that the surfaces of the blocks are uniformly treated. In principle, a non-uniformly aged appearance should certainly be produced, but this is obtained automatically by the movable fastening of the striking bodies. The offset arrangement reliably avoids a situation in which the blocks are increasingly struck (in a lasting manner) within a certain region due to the system. Provision may also be made in this respect for the distance between the rows to vary.

In a configuration of the solution according to the invention with a continuously working conveying device, it is sufficient if at least the striking bodies of a row are arranged in such a way that their defined regions cover the entire width of the blocks passing through under the striking bodies.

In principle, just one row of striking bodies or a few rows of striking bodies may be sufficient in order to age the blocks. However, as has been found in practice, this does not produce an optimum aging appearance and also results in the speed of passage being relatively low.

In a configuration of the solution according to the invention in which no continuously working conveying device is provided, provision may be made for the striking bodies to be fastened in such a way that the defined regions of the individual striking bodies together cover at least the entire surface of the blocks - preferably fed in layers.

During the discontinuous aging, provision is made for the blocks to be fed in layers or as a unit to the region in which they are aged and for them to be aged in one operation, i.e. the blocks are not transported further until the aging has been completed.

In a modification of the discontinuous aging, a plurality of aging stations to which the blocks are fed in succession may also be provided, the blocks being aged in the desired manner after they have passed through all the aging stations.

In contrast to the discontinuous aging, provision is made during the continuous aging for the blocks to be transported constantly in the feed direction; that is to say a layer or unit of blocks is not fed specifically to the aging station or stations, but rather the process is a continuous process. This is also possible by feeding the blocks at intervals. To this end, the vibrating process need not be interrupted. In this case, the blocks are left in their position (no feed) for a relatively short period of time, e.g. 5 seconds, and are then transported further by a short distance. In tests, this has resulted in an

advantageous aging appearance without the blocks being struck increasingly due to the system.

According to the invention, provision may be made for
5 the defined regions of the striking bodies to overlap.

The space which is predetermined by the movable fastening and in which the striking bodies can move is preferably to be selected in such a way that the
10 striking bodies cannot penetrate into the intermediate space possibly forming between two blocks. According to the invention, provision is made in this case for the striking bodies to rest on the blocks in the rest state, that is to say when no vibrations act on the
15 blocks and the striking bodies.

However, it is also possible for the striking bodies to be arranged at a distance above the blocks. The blocks can therefore be transported through below the striking
20 bodies without being scratched. A distance between the blocks and the striking bodies is possible without any problems in particular in the case of thicker blocks, since the latter can be aged with a high amplitude and are thus pushed up accordingly. As has been found, a
25 distance increases the aging of the block edges and reduces the aging of the block surface, a factor which may be advantageous depending on the application or the desired appearance.

30 However, with regard to especially effective aging, it is appropriate if the striking bodies rest on the surface and therefore do not first have to overcome a distance (loss of striking energy). In particular during the aging of thin blocks, which are aged only
35 with a low amplitude on account of the risk of said blocks being rotated by the vibrations, contact between the striking bodies and the surface of the blocks is also appropriate in the rest state.

Provision may be made for the defined region within which the striking bodies can move on the surface of the blocks to correspond to a movement or deflection of the same of 5 - 40 mm, preferably 10 mm, in all
5 directions. Under the assumption that the striking bodies are spherical and have a diameter of 40 mm, this would result in a circular defined region having a diameter of preferably 60 mm. The circumference or the horizontal cross section of the striking bodies is
10 therefore extended by 10 mm horizontally in all directions for reproducing the defined region.

It is advantageous if the striking bodies are fastened in such a way that they can perform a largely
15 unrestricted lifting movement, resulting from the initiated vibrations.

In a constructive configuration of the invention, provision is made in this case for the retaining device
20 on which the striking bodies are fastened to be arranged above the blocks. Here, the retaining device may constitute a plane or a pattern of retaining elements which extend in a plane-parallel manner to the surface of the blocks and are formed, for example, by a
25 plurality of retaining rows running transversely to the direction of passage of the blocks. The striking bodies may be fastened to the retaining elements via fastening members, which may be designed, for example, as chains, ropes, rods or profile elements of varying form. The
30 fastening members may be designed in various ways and should at the same time preferably ensure that the striking bodies can move as far as possible without restriction within the defined region and that, on the other hand, the striking bodies can carry out the
35 lifting movement without considerable energy loss.

The striking bodies are preferably each fastened individually to the retaining elements.

In a configuration of the apparatus according to the invention with a continuously working conveying device, provision may be made for means which lift at least a section of a block to be provided in the region through
5 which the blocks pass under the striking action of the striking bodies, so that the lifted section of the block projects in the direction of the striking bodies and is subjected to a more intense action of the striking bodies. The means may be designed, for
10 example, as prominences, over which the underside of the blocks are pushed on account of the feed movement (resulting from the conveying device). The prominences may preferably be of ramp-shaped design, so that the block travels up the ramp with at least one section and
15 then drops down again or travels down said ramp again. Thus, as viewed in the feed direction, first the front region of the block is lifted and is thus subjected to a more intense action of the striking bodies, whereas subsequently the middle region and finally the rear
20 region of the block projects in the direction of the striking bodies.

According to the invention, provision may be made for the prominences to be arranged in such a way that the
25 blocks, with their underside, are pushed eccentrically over the prominences, as a result of which one side of the block (as viewed in the direction of passage) is in each case subjected to increased aging. Provision is made in this case for each block to be lifted at least
30 once on each side. In order to reduce the friction between the prominence and the underside of the block, provision may be made for the prominences to have rollers or to be designed as rollers. However, owing to the fact that the blocks are continuously lifted in
35 this region anyway by the vibrating movement, the friction between the prominence and the block underside is not high in any case.

The means for lifting the blocks may also be designed in such a way as described in US 2002/0145224 A1.

Advantageous configurations and developments follow
5 from the further subclaims. Two exemplary embodiments of the invention are explained in principle below with reference to the drawing.

In the drawing:

10

fig. 1 shows a plan view of a production layer of blocks which are put onto a base and are brought into an aging region by means of a conveying device, without the striking bodies being shown;

15

fig. 2 shows a side view of the apparatus according to the invention, the striking bodies being arranged in rows transversely to the push-through direction of the blocks via fastening
20 elements;

fig. 3 shows a view according to arrow direction III in fig. 2;

25

fig. 4 shows a detailed view of the striking bodies, which are hung in rail-shaped receptacles via chain-shaped fastening elements;

30

fig. 5 shows an alternative configuration of the fastening elements with an interior space which encloses the retaining element;

35

fig. 6 shows a detailed illustration of a fastening element according to fig. 5 with a striking body;

fig. 7 shows a detailed illustration of a fastening element loaded eccentrically with a weight;

WO2006/136235

- 13 -

PCT/EP2006/004292

fig. 8 shows a perspective illustration of a conveying device which is especially suitable for conveying a layer of blocks, the blocks being pushed over a base by means of a push rod which is attached to a chain conveyor;

fig. 9 shows a diagrammatic side view of a conveying device according to fig. 8;

fig. 10 shows a perspective illustration of a conveying device, a chain conveyor being provided which has at least one push rod and one limit stop rod, and a mat being attached between the push rod and the limit stop rod, the blocks resting on this mat and being pulled over the base;

fig. 11 shows a diagrammatic side view of a conveying device according to fig. 10;

fig. 12 shows a diagrammatic side view of a conveying device having a chain conveyor with at least one push rod, a band or belt conveyor on which the blocks rest additionally being provided; and

fig. 13 shows a diagrammatic side view of a conveying device according to fig. 9, having a configuration of the push rod and of the limit stop rod which is especially suitable for the aging of blocks which are of trapezoidal cross section or are unstable in their position.

According to the invention, any desired blocks, for example surfacing elements, facade elements, sand-lime blocks, concrete blocks, bricks or clinker bricks or natural stone blocks, can be aged irrespective of their material condition. The aging of blocks 1 which are

designed as concrete blocks will be explained below with reference to the exemplary embodiments. However, the invention is of course not restricted thereto.

5 The production of concrete blocks 1, in particular of concrete paving blocks, is sufficiently well known, for which reason this will not be dealt with in any more detail below. The concrete blocks 1 leave the production plant generally in a production layer, i.e.
10 in an arrangement in which a multiplicity of concrete blocks 1 are arranged next to one another in a single layer. Such a production layer is shown by way of example in fig. 1.

15 As can be seen from fig. 1, the concrete blocks 1 are put onto a base 2 in a single layer in a regular arrangement. Here, the concrete blocks 1 are arranged in such a way that in each case that edge 1b or that surface 1a (= the subsequent visible side as a rule) of
20 the block 1 which is to be treated lies at the top.

With regard to the general principle of aging with freely movable striking bodies 3, as can be seen from figures 2 to 7, reference is made to DE 20 2004 020
25 206.9.

As can be seen from figures 2 to 6, the surfaces 1a and the edges 1b adjoining the surfaces 1a of the blocks 1 are treated by striking bodies 3 which are essentially
30 freely movable within a defined region 4 of the surface 1a of the blocks 1. To this end, the striking bodies 3 are movably fastened and arranged or suspended on a retaining device 5.

35 As can be seen in particular from figures 2 and 3, a vibrating device 6 is provided in order to set the blocks 1 and the striking bodies 3 in motion relative to one another in such a way that the striking bodies 3 act on the surfaces 1a and the exposed edges 1b of the

blocks 1. The vibrating device 6, which may consist, for example, of a plurality of unbalance generators, transmits the vibrating movement to the base 2 and acts from there on the blocks 1 and the striking bodies 3. In this case, the base 2 may also constitute the top side of the vibrating device 6, for example a vibrating table. However, the base 2 may also constitute a conveyor band, on which the blocks 1 are placed. With regard to advantageous configurations in this respect and to the initiation of the vibrating movement, reference is made to DE 20 2004 020 206.9.

As can be seen from the figures, the striking bodies 3 are freely movable both within the defined region 4 relative to the surface 1a and relative to one another. The striking bodies 3 may be made of any desired material. In the exemplary embodiment, provision is made for the striking bodies 3 to be made of carbide, metal or steel. Any desired shape of the striking bodies 3 may likewise be selected, it having proved to be advantageous for the striking bodies 3 to be of spherical, annular, polygonal, cylindrical or disk-shaped design. In the exemplary embodiment shown, the striking bodies 3 are essentially spherical, but are flattened on two opposite sides. This can be seen in detail in particular from figures 4, 6 and 7.

As can be seen when viewing fig. 2 and fig. 3 together, the retaining device 5 extends in a plane-parallel manner relative to the surfaces 1a of the blocks 1. In this case, the retaining device 5 has a plurality of retaining elements 7, which each extend over the entire width of the blocks 1 to be aged, i.e. transversely to the feed direction. The striking bodies 3 are arranged or fastened or suspended on the retaining elements 7 via fastening members 8. According to the embodiment shown in figures 2 to 4, the fastening members 8 are shown as chains. The chains in this case are designed as metal chains. As can be seen in particular from fig.

WO2006/136235

- 16 -

PCT/EP2006/004292

4, the retaining elements 7 have rail-shaped receptacles 7a, in which the metal chains 8 can be hung. Each striking body 3 is connected individually to the retaining element 7 via an individual fastening member 8. If a striking body 3 has to be exchanged, this is therefore possible in a simple manner.

In the embodiment, provision is made for the striking bodies 3 of a row 7 to lie closely adjacent to one another, for example to be at a distance apart of 2 to 20 mm, preferably 5 to 10 mm.

Furthermore, provision is made in the exemplary embodiment for the retaining elements 7 or for the entire retaining device 5 to move during the striking action of the striking bodies 3 on the blocks 1. This assists irregular striking of the blocks 1 by the striking bodies 3. Provision is made in this case for an oscillating movement of the retaining elements 7, preferably in such a way that the retaining elements 7 are moved axially back and forth. This can be achieved from the design point of view with known means (e.g. an eccentric mounting or a randomly controlled pneumatic cylinder).

25

An alternative configuration of the fastening members 8 to that in figures 2 to 4 is shown in figures 5, 6 and 7. In this case, the fastening members 8 have a profile which forms an interior space 8a, which is suitable for enclosing the retaining element 7 (tubular or rod-shaped in the exemplary embodiment) in such a way that the fastening member 8 is movable relative to the retaining element 7 in such a way that the striking body 3 arranged on the fastening member 8 or connected thereto can perform both a lifting movement and a movement within the defined region 4. According to the exemplary embodiment shown in figures 5, 6 and 7, the fastening member 8 is designed as an appropriately bent rectangular profile. According to the embodiment shown

30
35

in fig. 6, the defined region 4 has an elliptical shape. This is due to the fact that the fastening member 8 designed as a rectangular profile mainly permits a movement of the striking body 3 in the direction of passage or against the direction of passage. In contrast thereto, the embodiment according to figures 2 and 4 enables a defined region 4 which is round in principle to be formed. In this case, too, however, on account of the feed direction of the blocks 1, an elliptical shape for the defined region 4 will essentially appear, even though this shape is less highly pronounced.

According to the embodiment shown in fig. 6, provision may be made for it to be possible to deflect the striking bodies 3 by 30 to 200 mm, preferably by 50 to 150 mm, in the direction of passage. Furthermore, provision may be made in this case for the next row 7 with striking bodies 3 to be at a distance from the preceding row 7 with striking bodies 3 which is 10 to 20 mm greater than the maximum deflection of the striking bodies 3 during operation.

In the exemplary embodiment, the fastening members 8 including the striking bodies 3 have a length of 200 mm. A length of 100 to 400 mm has generally proved to be advantageous.

As can be seen from fig. 5, the retaining elements 7 have spacers 9 at regular distances apart, these spacers 9 ensuring a defined arrangement of the fastening members 8 of a row and preventing jamming with other adjacently arranged fastening members 8.

As can be seen from fig. 6, the interior space 8a of the fastening members 8 may be subdivided by an intermediate bottom 8b, as a result of which particularly the lifting movement of the striking body 3 is accordingly limited. In this case, provision may

WO2006/136235

- 18 -

PCT/EP2006/004292

be made for the intermediate bottom 8b to be capable of being set in a variable manner, as a result of which the lifting movement can be varied - if need be in relation to the blocks 1 to be aged.

5

Fig. 7 shows an arrangement of the striking bodies 3 in such a way that the striking bodies 3 are oriented against the direction of passage in the rest state. By the movement of the blocks 1 in the conveying direction (see arrow), the striking bodies 3 or the fastening members 8 are oriented perpendicularly in the process (illustrated by broken lines). The orientation of the striking bodies 3 in the rest state is selected in such a way that a perpendicular orientation occurs during operation. In the exemplary embodiment, the fastening members 8, on their side lying at the front in the direction of passage of the blocks 1, are loaded with an additional weight 15 (this may also be integrated in the fastening member). The additional weight 15 may also be attached to the striking body 3. The additional weight 15 achieves the effect that the striking body 3 is inclined against the conveying direction in the rest state. Such an inclination may also be achieved in another manner, e.g. by an asymmetrical or disproportional suspension and/or configuration of the fastening members 8 or of the striking bodies 3.

According to the invention, provision may likewise be made for at least the row 7 of striking bodies 3 which is arranged in the inlet region, i.e. the row of striking bodies 3 which the blocks pass first when being introduced into the aging region, to be inclined in the direction of passage (not shown). In terms of design, this may be effected in a similar manner to the inclination against the direction of passage. The advantage consists in the fact that jamming of the blocks 1 with the striking bodies 3 is avoided and the blocks 1 can therefore easily be fed. In an alternative embodiment (not shown), provision may also be made for

all the striking bodies 3 to be inclined in the direction of passage in the rest position.

In the exemplary embodiments, provision is made for the blocks 1 to be conveyed through below the striking bodies 3, i.e. for said blocks to pass through the actual aging region, by means of a conveying device 10. A plurality of different conveying devices 10 are known from the general prior art. For example, this may involve a band, belt or chain conveyor or the like. In the exemplary embodiment, the conveying device is designed as a chain conveyor 10 having a push rod 11 which pushes the blocks 1 over the base 2, i.e. in the actual aging region, directly over the vibrating table. Furthermore, provision is made in the exemplary embodiment for the chain conveyor 10 to push the blocks 1 continuously through below the striking bodies 3. In this case, the speed of passage can be determined in connection with the overall production rate or the aging result to be achieved.

Alternatively, provision may also be made for the chain conveyor 10 to merely push the blocks 1 to be aged, for example an entire production layer, into the intended position and for the blocks 1 not to be pushed forward during the aging process (discontinuous conveying). After completion of the aging process, i.e. once the striking bodies 3 have completed their striking action on the surfaces 1a and the adjoining edges 1b of the blocks 1 to the desired degree, the chain conveyor 10 can convey the blocks 1 further and introduce a new layer to the space which has become free.

The chain conveyor 10 is designed as a circulating conveying device. In the exemplary embodiment, the two tension chains of the chain conveyor 10 are guided outside the vibrating device 6 and their operability is therefore not impaired by vibrations. In principle, a multiplicity of design measures are conceivable in

order to ensure that the chain conveyor 10 is not subjected to vibrations. The push rod 11, which is arranged between the two circulating chains of the chain conveyor 10, is at a distance from the vibrating table or the base 2 that ensures that the vibrating table or the base 2 does not come into contact with the push rod 11. The distance between the push rod and the top side of the base 2 or of the vibrating table must therefore be greater than the maximum oscillation of the vibrating table or of the base 2 in the direction of the push rod 11. As a rule, the vibrating table or the base 2 oscillates or moves by no more than at most 4 mm in the direction of the push rod 11, so that a distance of, for example, 10 mm is sufficient in order to ensure that the vibrating table or the base 2 does not touch the push rod 11 and the latter can therefore run smoothly and unimpeded. The distance between the push rod 11 and the top side of the vibrating table or the base 2 depends in this case on the peak-to-peak displacement or the intensity of the vibration.

Fig. 1 shows an especially advantageous development of the push rod 11, which is especially suitable for use in the apparatus according to the invention. Provision is made here for the push rod 11 to be provided with a plurality of bearings 16 or rotatable elements, such as rollers for example. In this case, if the blocks 1 come into contact with the push rod 11 on account of their vibrations, the bearings 16 ensure that only minimum rubbing of the blocks 1 on the push rod 11 takes place, as a result of which only a little kinetic energy is lost. According to the invention, provision may be made in this case for the bearings 16 to have a width of 5 to 30 mm, preferably 10 mm, and to be arranged at a distance apart of 20 to 50 mm, preferably 30 mm. Firstly, this ensures that the blocks 1 each bear against at least two bearings 16 or are pushed forward by the latter. Secondly, there is little likelihood of two blocks 1 touching one bearing 16 simultaneously

during the vibration, in particular with an opposed movement, as a result of which the functioning of the bearing 16 would be restricted. Independently of the solution according to the invention, such a push rod 11
5 may also be used in other apparatuses in which blocks 1 are aged by means of a combination of a vibrating device and striking bodies which are arranged on the surface of the blocks 1.

10 Fig. 1 shows lateral limit stops 12 which are intended to prevent lateral escape of the blocks 1 during the vibrating process. In principle, such limit stops 12 may also be provided in front of and behind the blocks 1 in the direction of passage. The lateral limit stops
15 12 may in this case also serve as dust protection. Furthermore, provision may also be made for the retaining device 5 to have a protective hood or the like which encloses the layer of blocks 1 which is to be aged in order to reduce an escape of stone dust.

20

In the exemplary embodiment, provision is made for the limit stops 12 to be isolated from the vibrating device 6, that is to say they do not vibrate.

25 Simple design measures can ensure that the chain conveyor 10 conveys the push rod 11 in the direction of passage without the lateral limit stops 12 getting in the way. For example, the push rod 11 can be connected to the chain conveyor 10 below or above the lateral
30 limit stops 12.

As shown in figures 2 and 3 (only in principle), the region through which the blocks 1 pass under the striking action of the striking bodies 3 can have means
35 13 which lift at least a section of the blocks 1, so that the lifted section of the blocks 1 projects in the direction of the striking bodies 3 and is subjected to a more intense action of the striking bodies. In the exemplary embodiment, the means 13 are designed as

ramp-shaped prominences which accordingly lift the blocks when the latter, with their underside, pass the ramp-shaped prominences 13. In the exemplary embodiment (not shown), provision is made for the prominences 13 to lift the blocks 1 eccentrically and thus laterally, as viewed in the direction of passage, each block 1 being lifted at least once on each side.

As shown in fig. 2, the prominences 13 may be provided with rollers 14 or bearings.

In principle, such ramps 13 can also be realized if the conveying device is designed as a band conveying device, the band having to run over the prominences 13 in this case. However, a design as a chain conveyor having a push rod 11 has proved to be more advantageous for this purpose.

It is especially advantageous if the edges 1b of the blocks 1 are lifted. The means 13 may be designed in various ways, for example as projections, as extendable plungers according to US 2002/0145224 A1 or the like. It is likewise conceivable for the means 13 to be formed by a corrugated configuration of the base 2 or of the vibratory table.

The means 13 for lifting the blocks 1 at least in sections in such a way that the lifted part of the blocks 1 projects in the direction of the striking bodies 3 and is subjected to a more intense action of the striking bodies 3 may also be used independently of the inventive idea of movably fastening the striking bodies 3. For example, such a use is also possible in the apparatus according to DE 20 2004 020 206.9. During every treatment of blocks from above, owing to the fact that the blocks are lifted at least in sections, the treatment of this section can be intensified. A desired aging result can therefore be achieved in a simple manner.

For reasons of clarity, the blocks 1 are shown in the nonvibrating state in figures 2, 3 and 5, the striking bodies 3 resting on the surfaces 1a of the blocks 1.
5 The blocks 1 and the striking bodies 3 strike one another due to the vibration.

The distance, shown in figs. 2 and 5, between the blocks 1 (in the direction of passage), is reduced or
10 eliminated during a forward movement of the push rod 11.

In an especially advantageous manner, the solution according to the invention is also suitable for the
15 aging of split blocks, which generally have an uneven surface or a surface provided with prominences and recesses. In this case, the split area of the block 1 is turned with its fracture surface toward the striking bodies 3.

20 Figures 8 to 12 show three different advantageous conveying devices 10 which are not only suitable for the solution according to the invention but are also generally suitable for conveying a multiplicity of
25 blocks which are arranged in a production layer. The conveying device 10, as follows from the figures described below, therefore constitutes an independent solution according to the invention for conveying blocks if the blocks are to be aged using a vibrating
30 device 6.

Figs. 8 and 9 show the conveying device 10 in an especially cost-effective embodiment. In this case, the two chain strands of the chain conveyor each run in the
35 marginal region of the base 2 and are arranged in such a way that said chain strands are not set in vibration or are not set substantially in vibration by the vibrating device 6. Arranged between the chain strands

WO2006/136235

- 24 -

PCT/EP2006/004292

of the chain conveyor 10 is the push rod 11 already described, which serves to move the blocks 1 resting on the base 2 in the conveying direction. In the process, the push rod 11 pushes the blocks 1 over the base 2. 5 Such conveying can already be seen from figures 1 to 3 and fig. 5. In addition to this, a limit stop rod 17 is shown according to the embodiment shown in fig. 8 and fig. 9, said limit stop rod 17 being arranged in front of the push rod 11 in the conveying direction. A layer 10 of blocks 1 that is to be aged is placed between the limit stop rod 17 and the push rod 11. The limit stop rod 17, which is arranged between the chain strands of the chain conveyor 10 or is connected to said chain strands in a similar manner to the push rod 11, is 15 intended to prevent the blocks 1 from escaping at the front, i.e. in the conveying direction.

The limit stop rod 17 could in principle also be designed as a push rod for a further layer of blocks, 20 but this has not turned out to be advantageous. If a distance is left between the limit stop rod 17 and a push rod 11 for a further layer of blocks 1, the limit stop rod 17 can be set for different lengths of block layers without this affecting all the other push and 25 limit stop rods. The change in the length between a push rod 11 and an associated limit stop rod 17 for accommodating a block layer therefore only has an effect on the distance between the limit stop rod 17 and a further push rod 11 running in front of it. It is 30 therefore possible to select a separate modular dimension for each block layer and change it if need be without this affecting the modular dimension of other units (push rod/limit stop rod). Provision is therefore made according to the embodiment shown in figs. 8 and 35 fig. 9 for a push rod 11 and a limit stop rod 17 to be used for each block layer.

In a preferred configuration, both the push rod 11 and the limit stop rod 17 can be designed as flat steel bars or the like.

5

Shown in figures 10 and 11 is a preferred embodiment of the conveying device 10, which differs from the embodiment shown in figures 8 and 9 in that a rest 18 is mounted on or fastened to the limit stop rod 17. The limit stop rod 17 therefore serves as pull rods for the rest 18. In contrast to the embodiment shown in fig. 8 and fig. 9, the blocks consequently no longer rest on the base 2 during the aging process but rather on the rest 18, which is essentially pulled over the base 2 by the limit stop rod 17 or the chain conveyor 10. In this case, the rest 18 is in such contact with the base 2 or the vibrating device 6 that the rest 18 is set in vibration, such that the blocks 1 arranged on the rest 18 likewise vibrate or jump. The rest 18 is preferably made of an elastic material. A rubber mat 18 is especially suitable for this purpose. The rubber mat 18 can likewise be connected to the push rod 11.

Owing to the fact that the rubber mat 18 is connected to the limit stop rod 17 and possibly the push rod 11, the rubber mat 18 moves at the same speed as the chain conveyor 10. In the embodiment shown in fig. 10 and fig. 11, the rubber mat 18 is arranged essentially between the limit stop rod 17 and the push rod 11. In principle, the rubber mat 18 can also be longer or shorter than the distance between the limit stop rod 17 and the push rod 11.

The rest 18 or the rubber mat has turned out to be especially important for a good aging result. This is due to the fact that, in the case of a conveying device

WO2006/136235

- 26 -

PCT/EP2006/004292

10, as shown in fig. 8 and fig. 9, the pushing pressure which the push rod 11 exerts on the blocks 1 becomes increasingly higher the closer the blocks 1 are arranged to the push rod 11. A situation may occur in
5 which the blocks 1 are pushed together in such a way that the blocks 1, in particular in the region of the push rod 11, jump to a smaller extent or no longer jump. This effect is all the more noticeable, the smaller the blocks are, because the block rows on which
10 a lower pushing pressure is exerted, that is to say the block rows which lie at the front in the conveying direction, jump to a markedly higher degree or vibrate much more intensely and thus their block edges are struck more intensely. This effect is compensated for
15 by the rest 18, since the rest 18 and therefore also the resting blocks 1 are not pushed but rather pulled. The blocks 1 are therefore no longer pressed together in the region of the push rod 11, as is the case in the embodiment shown in fig. 8 and fig. 9. Although the
20 blocks 1 nonetheless still press against the push rod 11 - since the blocks 1 are moved at a lower speed than the rest 18 on account of the vibration or the jumping on the rest 18 - the pushing pressure acting on the blocks 1 due to the push rod 11 is markedly lower and
25 no longer occurs in a disturbing manner. If need be, the entire conveying device 10 can be slightly inclined, such that the blocks 1 run slightly downward as viewed in the conveying direction, thereby countering the effect that said blocks 1 shift rearward
30 in the conveying direction relative to the rest 18.

The rest 18 offers yet another advantage over the embodiment shown in fig. 8 and fig. 9. As tests have shown, the risk of fracture in the case of very thin
35 blocks or in the case of long blocks or blocks of large surface area is relatively high. Due to the rest 18, in

particular if it is made of an elastic material, the risk of fracture is considerably reduced, since the blocks 1 no longer strike the base 2, which as a rule is made of steel, but rather strike an elastic
5 material, preferably rubber.

Fig. 12 shows a modification of the embodiment of the conveying device 10 shown in fig. 10 and fig. 11, said modification having essentially the same advantages.
10 The embodiment according to fig. 12 likewise has a chain conveyor 10 and a push rod 11 and an optional limit stop rod 17, which are arranged in a similar manner to the embodiments according to fig. 8 and fig. 9 or fig. 10 and fig. 11. Provision is made here for
15 the blocks 1 to rest on a rest 18 which moves the blocks 1 in the conveying direction at least approximately at the speed of the conveying device 10. The rest 18 is in this case designed as a circulating conveying band which is preferably made essentially of
20 an elastic material, for example rubber. The conveying band 18 runs in such a way that it is set in vibration by the vibrating device 6, as a result of which the resting blocks 1 jump or vibrate. The conveying device 10 is preferably arranged in such a way that neither
25 the chain strands nor the push rod 11 or the limit stop rod 17 vibrate. Provision may optionally be made for the conveying band 18 to be connected to one or more limit stop rods 17 or push rods 11. The actual feed with which the blocks 1 are transported through the
30 aging region in the conveying direction is based on the feed movement of the conveying band 18. However, the blocks 1 shift rearward (at a low speed) relative to the conveying band 18 on account of their vibration. This rearward movement is correspondingly limited by
35 the push rod 11. However, the pushing pressure which the push rod 11 exerts on the blocks 1 is in this case

WO2006/136235

- 28 -

PCT/EP2006/004292

so low that it does not disturb the vibration or the jumping movement of the blocks 1. The limit stop rod 17 prevents the blocks 1 from being able to leave the intended region at the front.

5

Instead of a chain conveyor 10, another conveying device which is preferably designed to circulate can also be used in the embodiment according to figures 8 to 12.

10

Fig. 13 shows a configuration of the push rod 11 and of the limit stop rod 17 which is especially suitable for the aging of blocks 1 which are of trapezoidal cross section or are generally unstable in their position.

15

Such blocks 1 may be, for example, split blocks, which generally have an uneven surface or a surface provided with prominences and recesses. The inventor has found that, irrespective of the embodiment of the conveying device (not shown in fig. 13) and irrespective of the

20

way in which the blocks are transported through the aging region (figures 8 to 12), the aging result of blocks 1 which rest on the base 2 in an unstable manner can be improved by the push rod 11 and the limit stop rod 17 being designed in such a way that they support

25

the blocks 1. In the embodiment shown in fig. 13, both the push rod 11 and the limit stop rod 17 have an additional supporting element 11a and 17a, respectively. Alternatively, a plurality of supporting elements may also be provided, or the push rod 11 and

30

the limit stop rod 17 as such may have a shape which is suitable for supporting the blocks 1 and for avoiding their tilting. The supporting elements 11a, 17a ensure that the surfaces 1a of the blocks 1 form as horizontal a plane as possible, such that the block surfaces 1a can be advantageously aged by the striking bodies 3.

35

WO2006/136235

- 29 -

PCT/EP2006/004292

Alternatively, provision may also be made for only the push rod 11 or the limit stop rod 17 to have supporting elements.

- 5 The described embodiment of the push rod 11 and of the limit stop rod 17 shown in fig. 13 can be applied to all the embodiments described above.

WH-13287CA
SN 2,612,884

- 30 -

Patent Claims

1. An apparatus for the artificial aging of blocks (1) which each have a treatment surface (1a) and adjoining edges (1b), the apparatus comprising:

1.1 a base (2) on which the blocks (1) can be placed in such a way that their surface (1a) to be treated and the adjoining edges (1b) are exposed;

1.2 a retaining device (5) arranged above the base (2) and having a plurality of retaining elements (7), on which, for treating the surfaces (1a) and the adjoining edges (1b) of the blocks (1), striking bodies (3) are movably fastened in such a way that the fastening allows a movement of the striking bodies (3) within a defined region of the surface (1a) of the blocks (1);

1.3 a vibrating device (6) for setting the base (2), on which the blocks (1) rest, in vibration, for setting the blocks (1), which rest on the base (2), and the striking bodies (3) in motion relative to one another in such a way that the striking bodies (3) act on the surface (1a) and the adjoining edges (1b) of the blocks; and

1.4 means for moving the retaining elements (7) in an oscillating manner during a striking action of the striking bodies (3) on the blocks (1), for facilitating irregular striking of the blocks (1) by the striking bodies (3).

2. The apparatus as claimed in claim 1, characterized in that the striking bodies (3) are fastened in such a way that the individual striking bodies (3) together cover at least the entire surface of the blocks (1) to be treated.

3. The apparatus as claimed in either of claims 1 and 2, characterized in that the defined region (4) has an essentially elliptical shape which extends with its main axis in a direction of passage.

WH-13287CA
SN 2,612,884

- 31 -

4. The apparatus as claimed in claim 1, 2 or 3, characterized in that the striking bodies (3) are fastened to be out of contact with the blocks (1) if the blocks (1) and the striking bodies (3) are stationary.

5. The apparatus as claimed in one of claims 1 to 4, characterized in that the retaining device (5) has a pattern of the retaining elements (7) which extend in a plane-parallel manner relative to the surface of the blocks (1).

6. The apparatus as claimed in claim 5, characterized in that the striking bodies (3) are each fastened individually to the retaining elements (7).

7. The apparatus as claimed in one of claims 1 to 6, characterized in that the striking bodies (3) are fastened to the retaining elements (7) via fastening members (8).

8. The apparatus as claimed in claim 7, characterized in that the fastening members (8) are designed as chains, ropes, rods, and profile elements.

9. The apparatus as claimed in claim 7, characterized in that the fastening members (8) have a profile which forms an interior space (8a) which is suitable for enclosing a tube or a rod-shaped retaining element (7) in such a way that the fastening members (8) are movable relative to the retaining element (7) in such a way that the striking body (3) attached to the fastening members (8) can perform a lifting movement.

10. The apparatus as claimed in one of claims 1 to 9, characterized in that a conveying device (10) is provided in order to convey the blocks (1) through below the striking bodies (3).

WH-13287CA
SN 2,612,884

- 32 -

11. The apparatus as claimed in claim 10, characterized in that the conveying device (10) works continuously.

12. The apparatus as claimed in claim 10 or 11, characterized in that the conveying device (10) works in a circulating manner.

13. The apparatus as claimed in claim 10, 11 or 12, characterized in that the conveying device (10) has a push rod (11).

14. The apparatus as claimed in one of claims 10 to 13, characterized in that the conveying device (10) has a limit stop rod (17).

15. The apparatus as claimed in one of claims 10 to 14, characterized in that the blocks (1) rest on a rest (18) which moves the blocks (1) in a conveying direction at a speed of the conveying device (10) or greater.

16. The apparatus as claimed in claim 15, characterized in that the rest (18) is arranged in such a way that vibrations of the vibrating device (6) can be transmitted to the rest (18).

17. The apparatus as claimed in claim 15 or 16, characterized in that the rest is a circulating conveying band (18).

18. The apparatus as claimed in claim 17, characterized in that the conveying band (18) is made essentially of an elastic material.

19. The apparatus as claimed in claim 15 or 16, characterized in that the rest (18) is transported along by the conveying device (10).

WH-13287CA
SN 2,612,884

- 33 -

20. The apparatus as claimed in claim 19, characterized in that the rest (18) is arranged between a push rod (11) and a limit stop rod (17).

21. The apparatus as claimed in claim 20, characterized in that the rest (18) is pulled essentially by the limit stop rod (17), which runs in front of the push rod (11).

22. The apparatus as claimed in claim 19, 20 or 21, characterized in that the rest (18) is made essentially of an elastic material.

23. The apparatus as claimed in any one of claims 20 to 22, characterized in that the push rod (11) is provided with a plurality of rotatable elements.

24. The apparatus as claimed in one of claims 1 to 23, characterized in that at least one of the retaining device (5) and the retaining elements (7) are movable during the striking action of the striking bodies (3) on the blocks (1).

25. The apparatus as claimed in claim 24, characterized in that the retaining elements (7) oscillate.

26. The apparatus as claimed in claim 24 or 25, characterized in that the retaining elements (7) are movable back and forth axially.

27. The apparatus as claimed in one of claims 1 to 26, characterized in that the striking bodies (3) are arranged or designed in such a way that, in the rest state, the striking bodies (3) are oriented against a direction of passage of the blocks (1).

28. The apparatus as claimed in one of claims 1 to 26, characterized in that at least the striking bodies (3)

WH-13287CA
SN 2,612,884

- 34 -

which lie at a rear in a direction of passage and which the blocks (1) pass first when running into an aging region are oriented in the direction of passage in a rest state.

29. The apparatus as claimed in one of claims 10 to 26, characterized in that means (13) which lift at least a section of the blocks (1) are provided in a region through which the blocks (1) pass under the striking action of the striking bodies (3), so that the lifted section of the block (1) projects in a direction of the striking bodies (3) and is subjected to a more intense action of the striking bodies (3).

30. The apparatus as claimed in claim 29, characterized in that the means which lift at least a section of the blocks are prominences (13), over which the conveying device (10) pushes an underside of the blocks (1).

31. The apparatus as claimed in claim 30, characterized in that the prominences (13) lift the blocks (1) laterally as viewed in a direction of passage.

32. The apparatus as claimed in claim 30 or 31, characterized in that the prominences (13) are arranged in such a way that each block (1) can be lifted at least once on each side.

33. The apparatus as claimed in one claim 30, 31 or 32, characterized in that the prominences (13) are of ramp-shaped design.

34. The apparatus as claimed in one of claims 30 to 33, characterized in that the prominences (13) have rollers (14).

35. A method for the artificial ageing of blocks, which each have a treatment surface (1a) and adjoining edges

WH-13287CA
SN 2,612,884

- 35 -

(1b), the method comprising placing the blocks (1) onto a base (2) in such a way that the treatment surface (1a) of the blocks (1) and the adjoining edges (1b) are exposed, according to which the treatment surface (1a) of the blocks (1) is brought into contact with a plurality of striking bodies (3) which, due to being fastened in a movable manner, are essentially freely movable in each case within a defined region (4) of the treatment surface (1a) of the blocks (1), and according to which the blocks (1) and the striking bodies (3), by the initiation of vibrations, are set in motion relative to one another in such a way that the striking bodies (3) act on the treatment surface (1a) and the adjoining edges (1b) according to which a retaining device (5) having a plurality of retaining elements (7) oscillates during a striking action of the striking bodies (3) on the blocks (1), for facilitating irregular striking of the blocks (1) by the striking bodies (3).

36. The apparatus as claimed in claim 3 wherein the elliptical shape of the defined region has a main axis of a length of 60 to 400 mm.

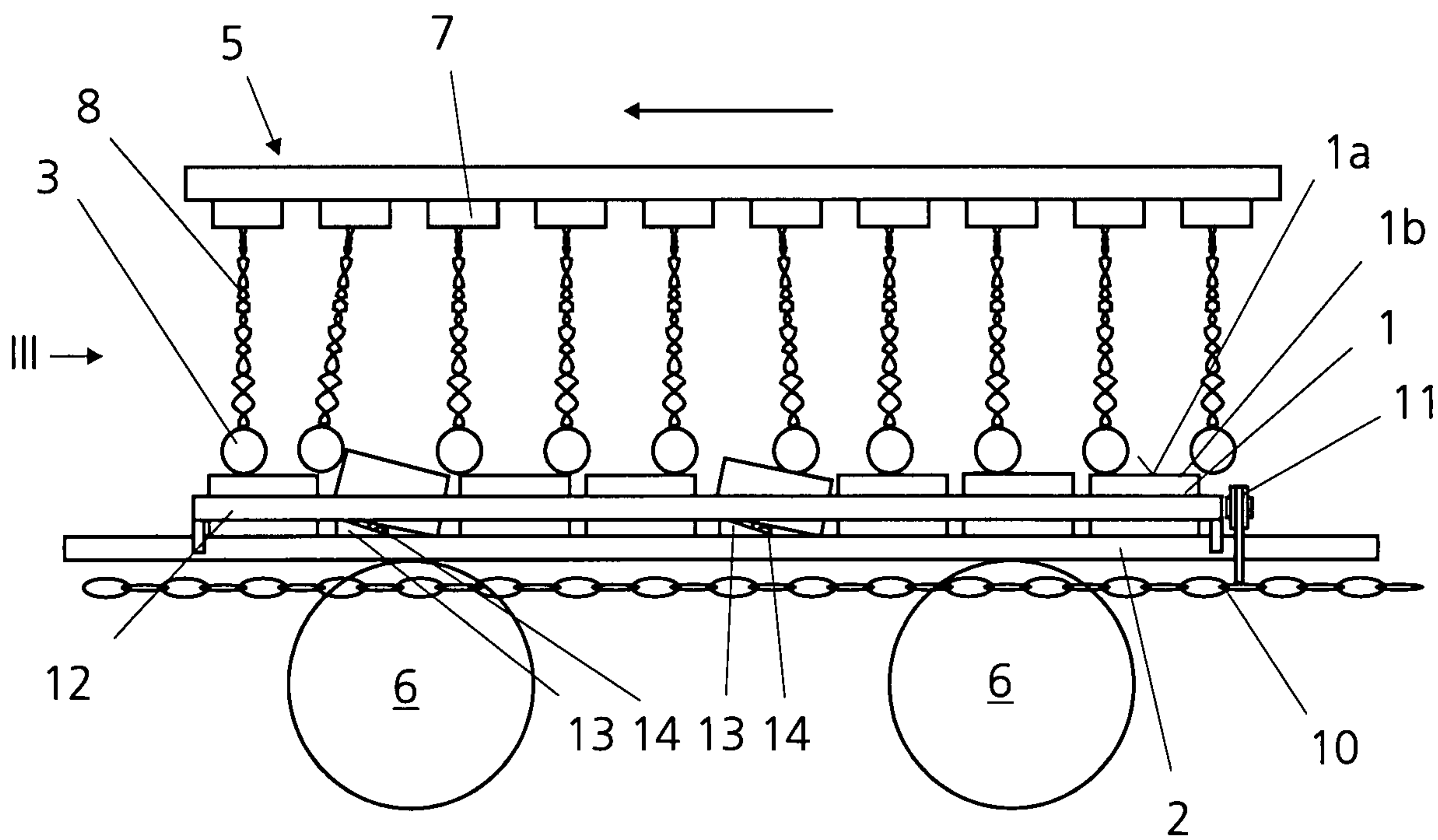
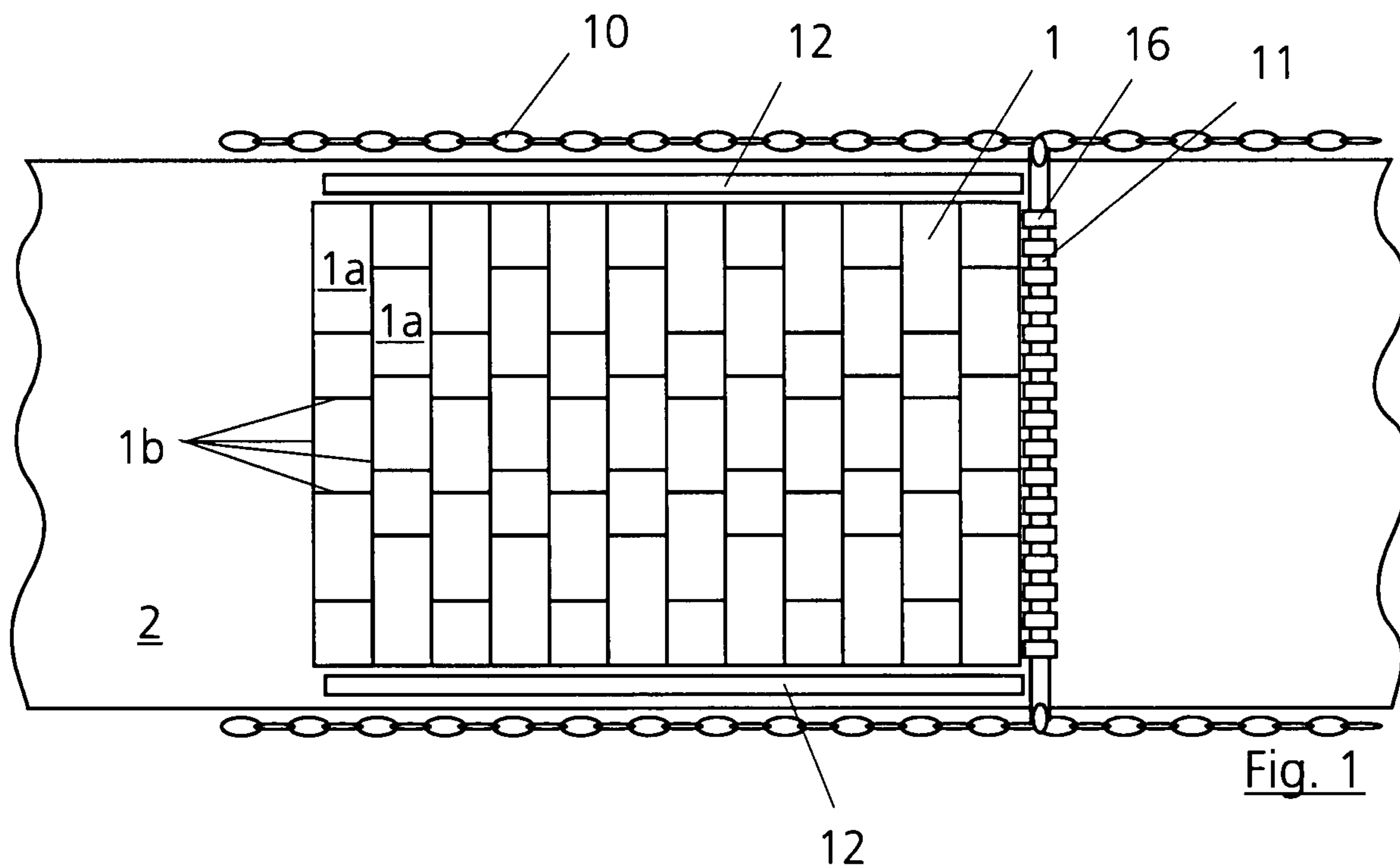

Fig. 2

2/6

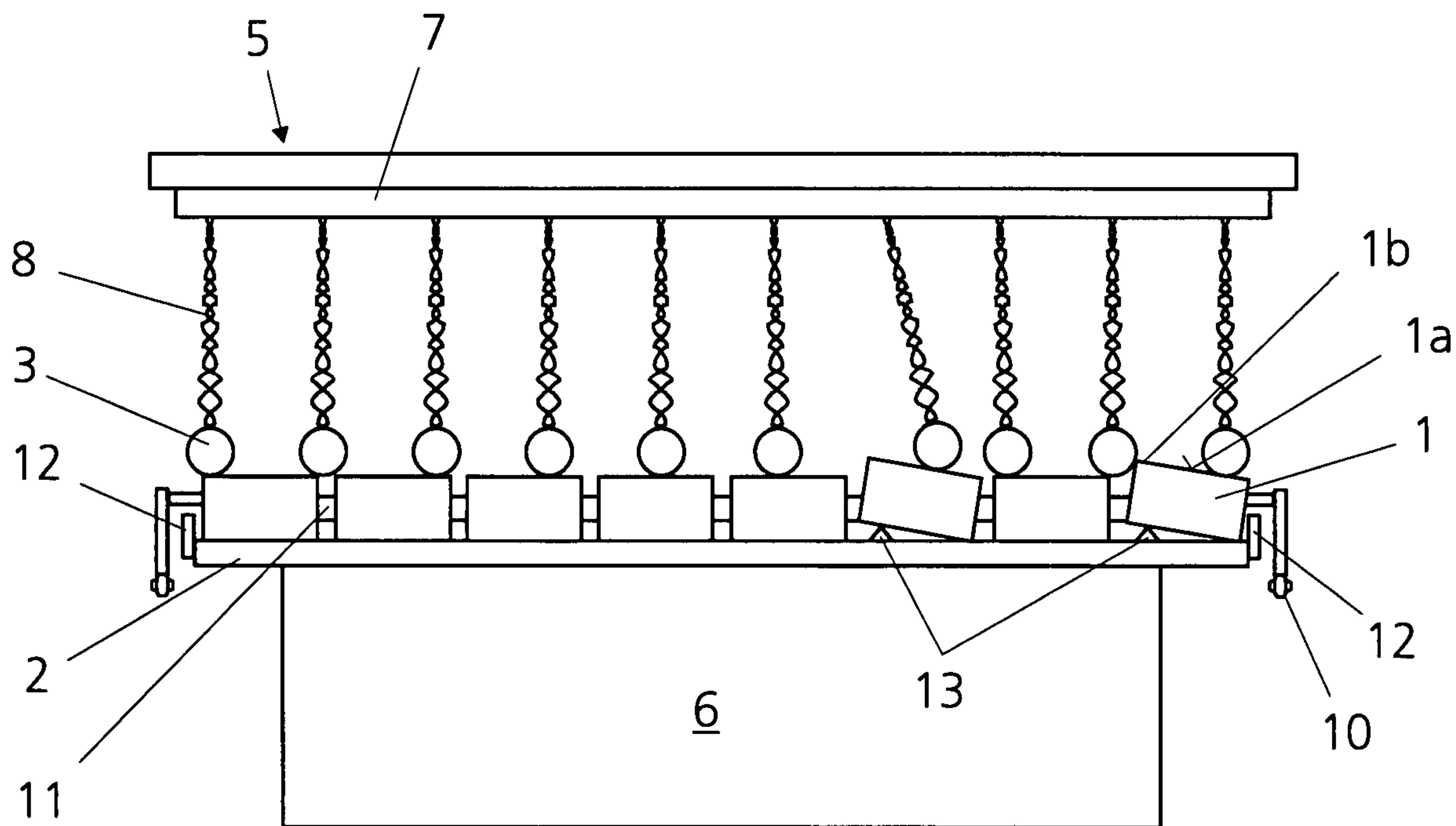

Fig. 3

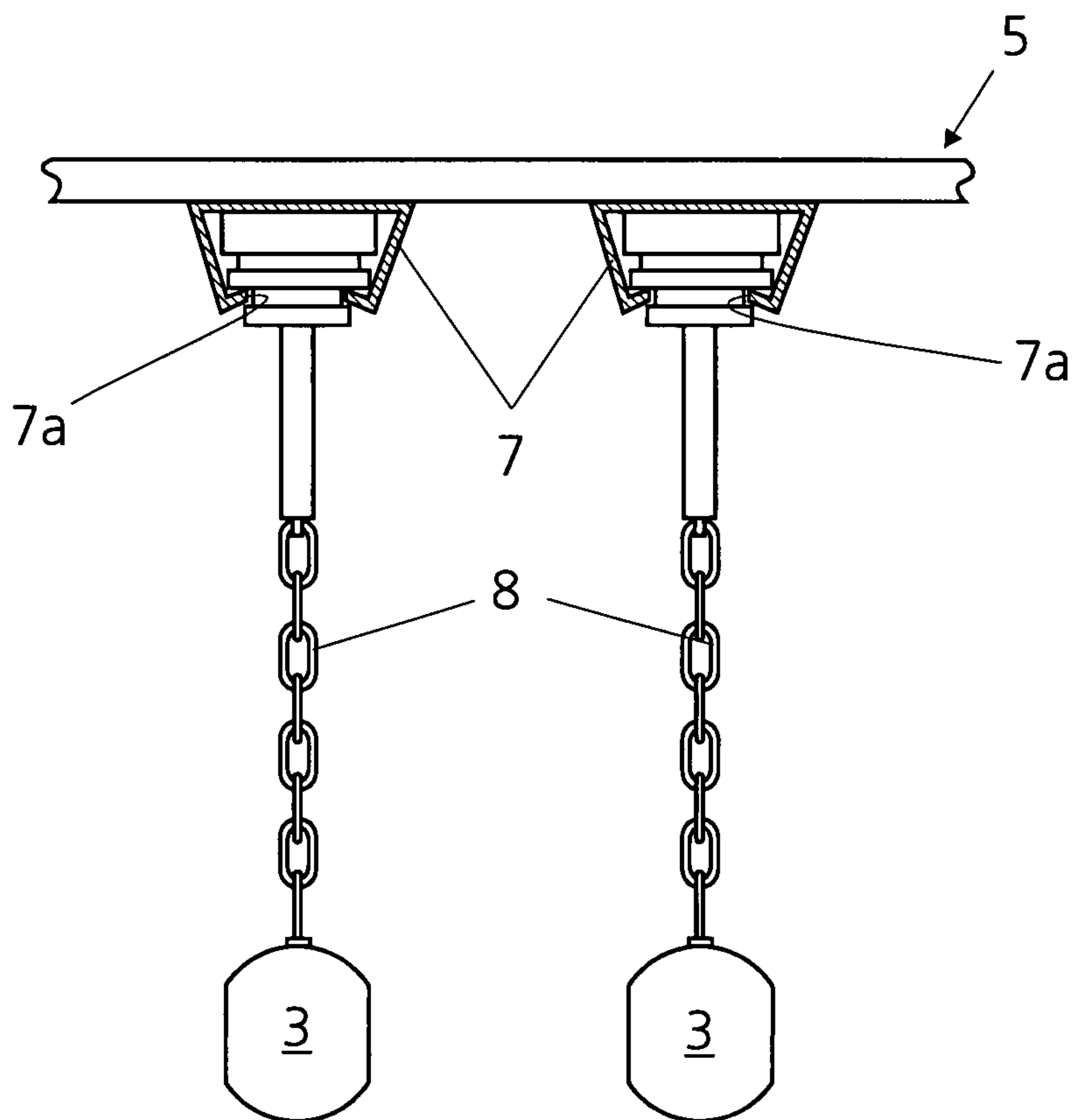

Fig. 4

3/6

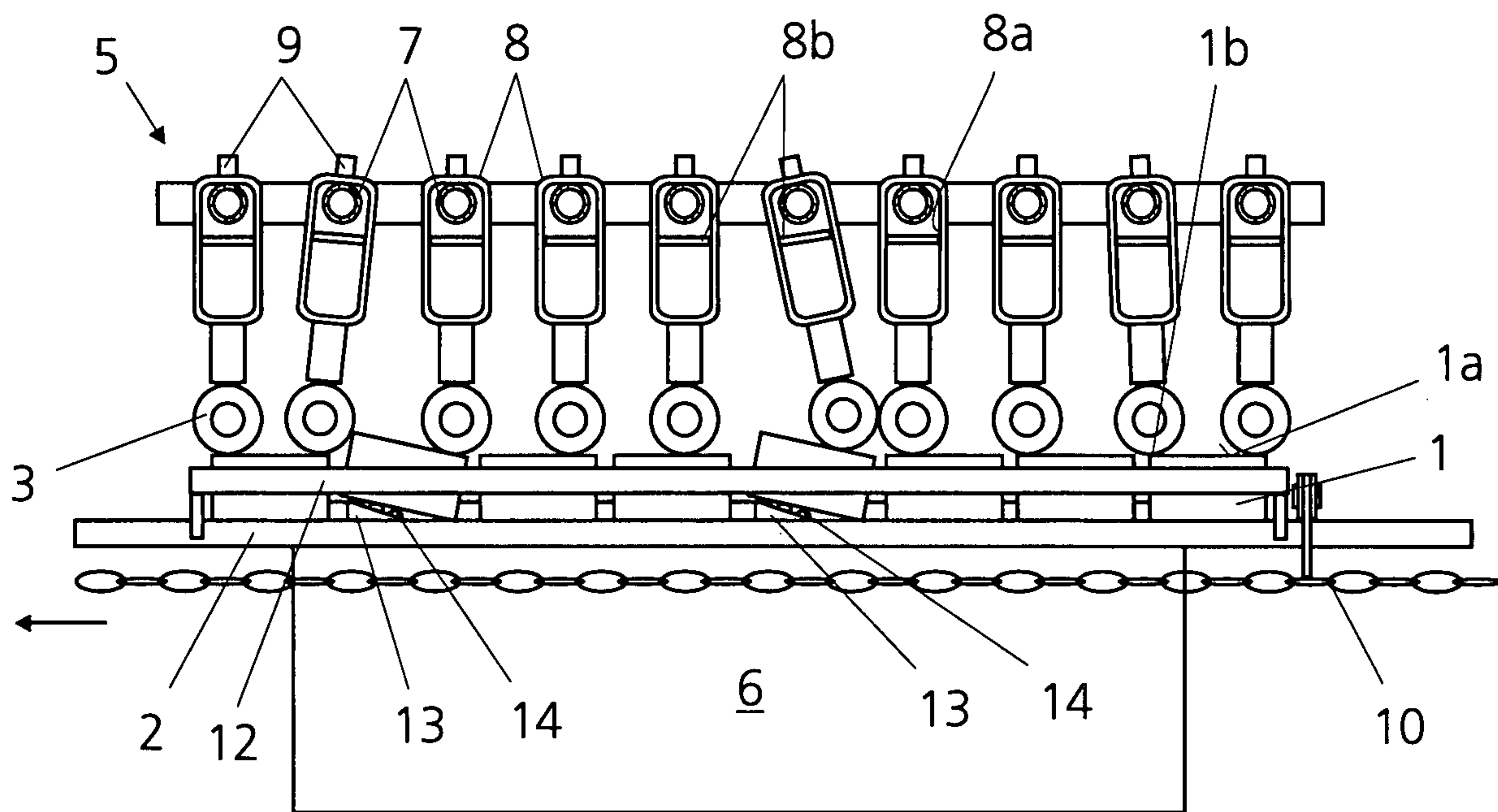

Fig. 5

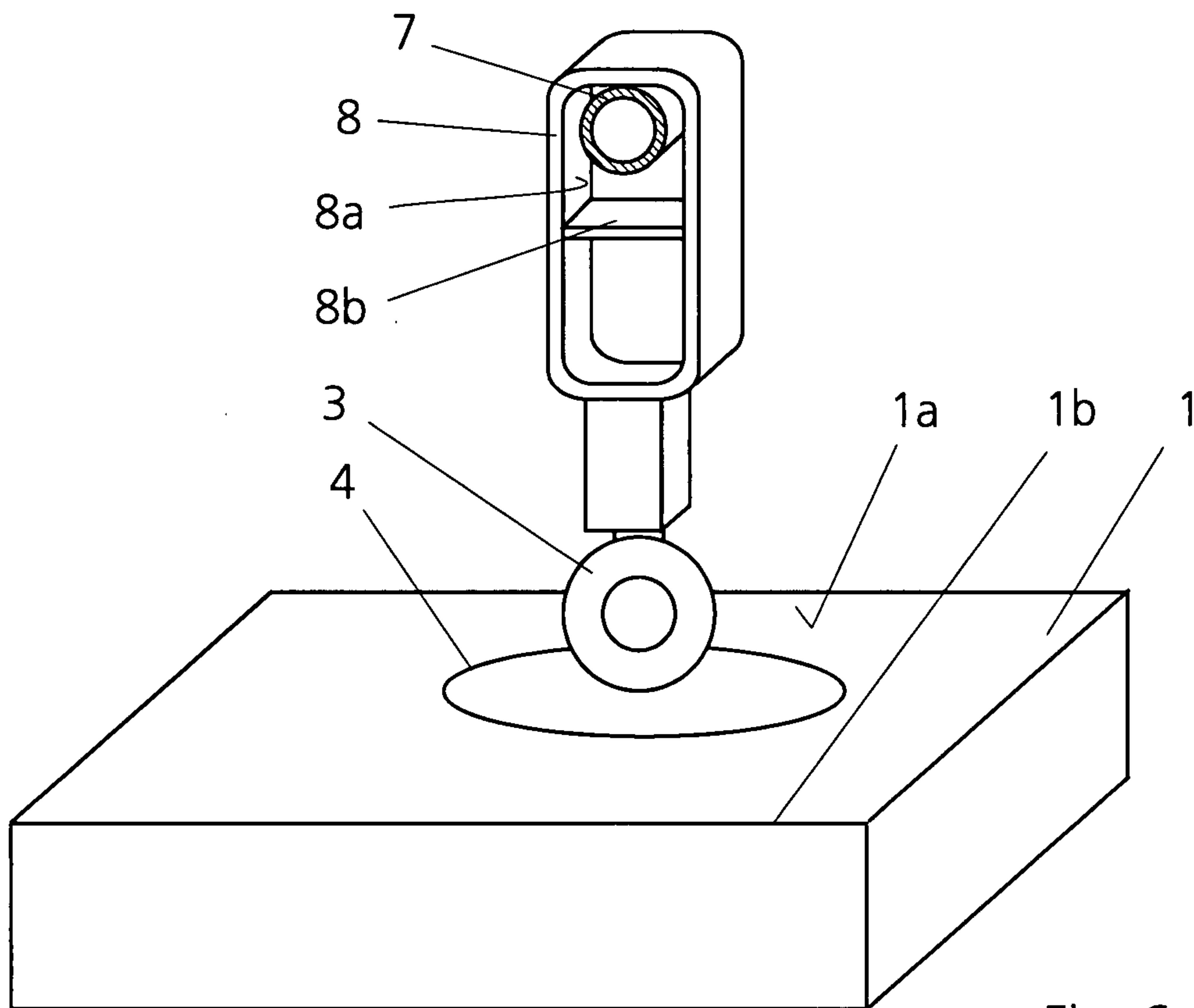

Fig. 6

4/6

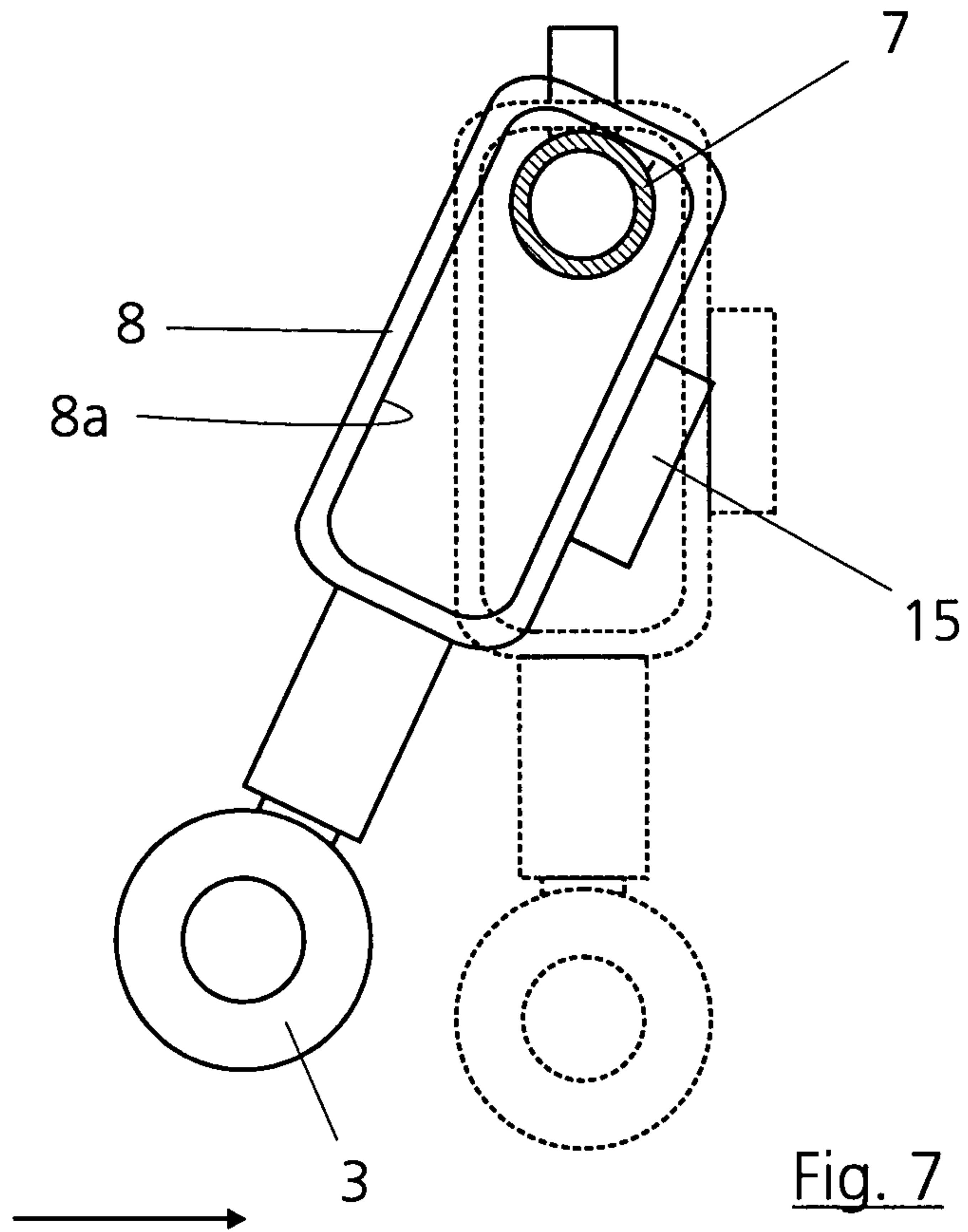

Fig. 7

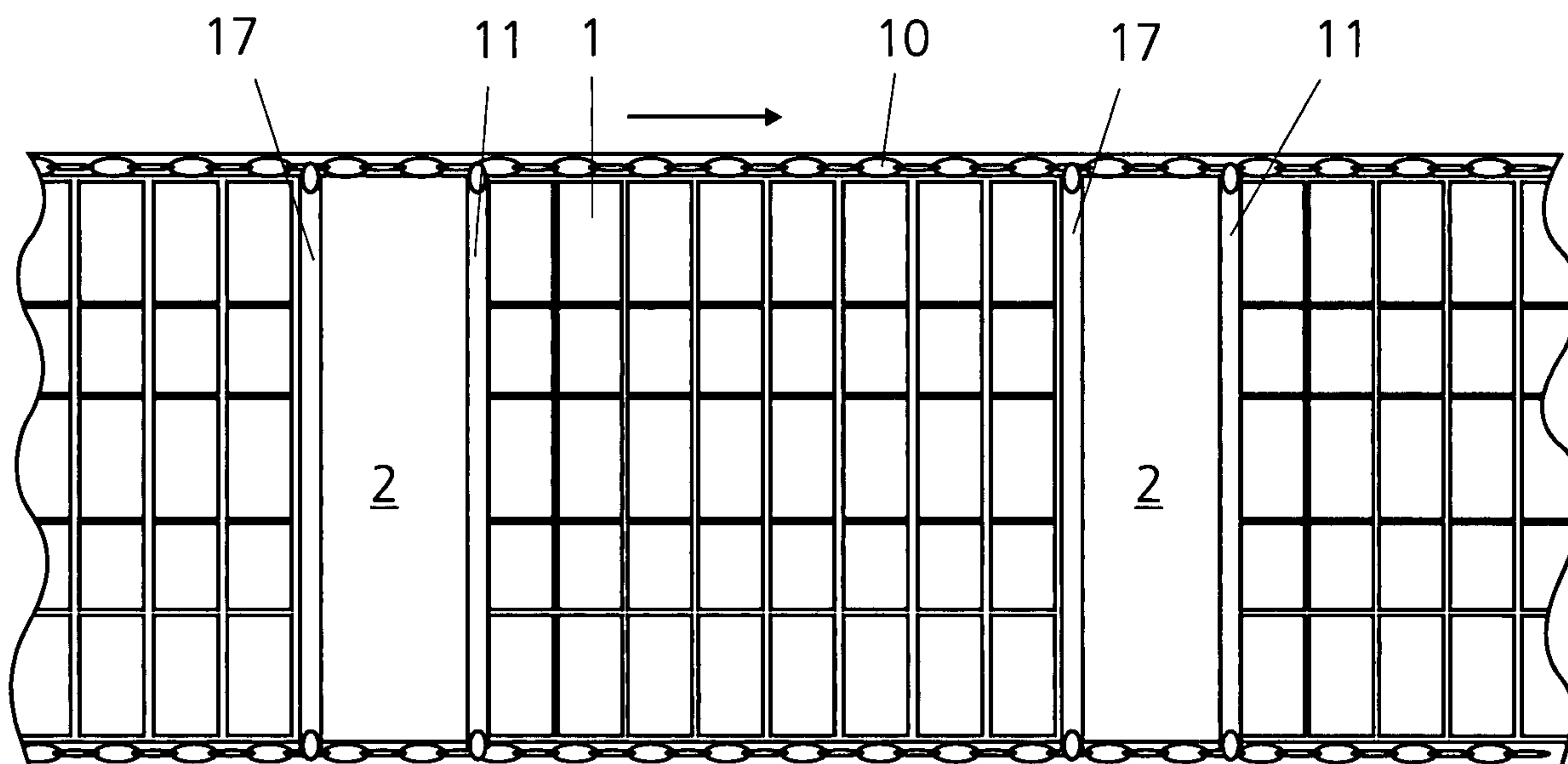
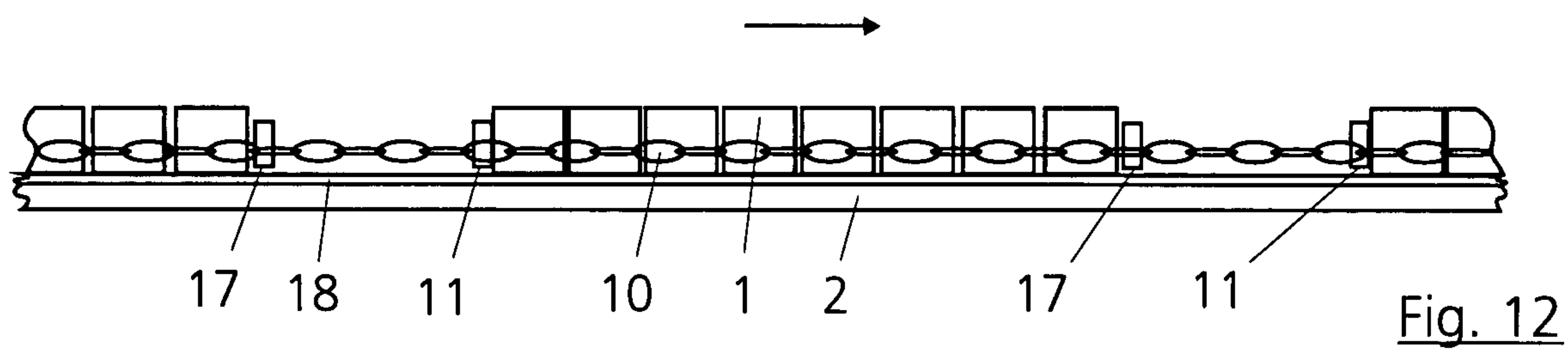
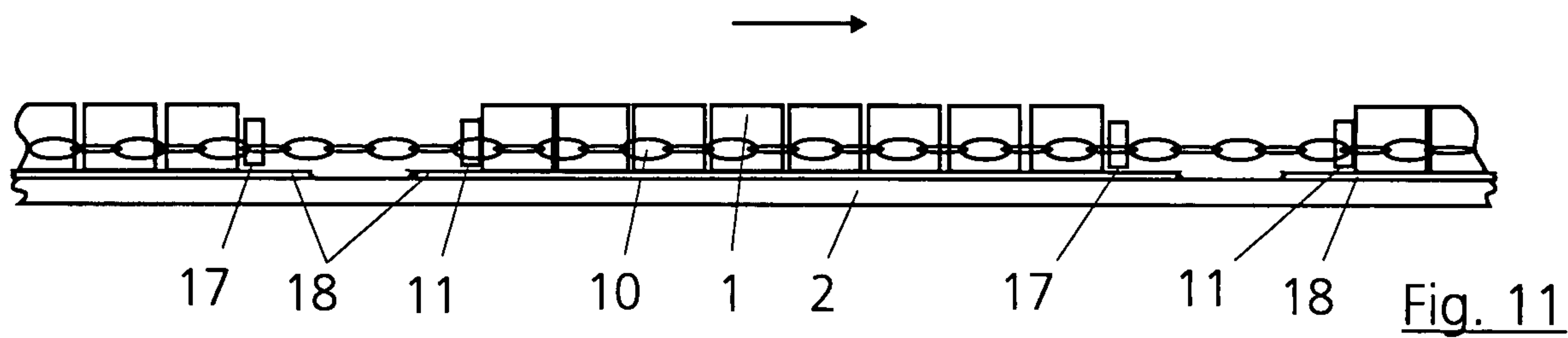
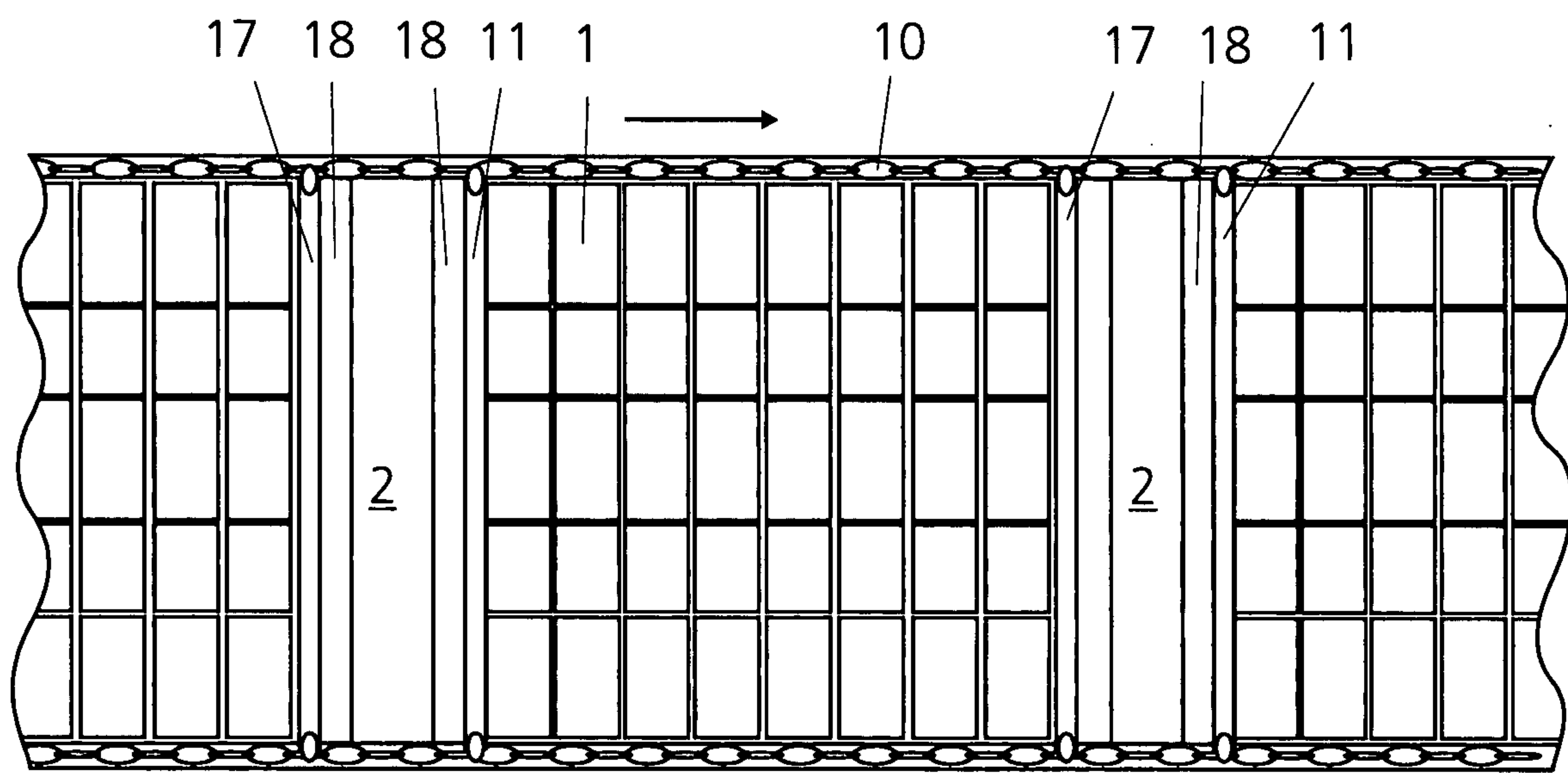
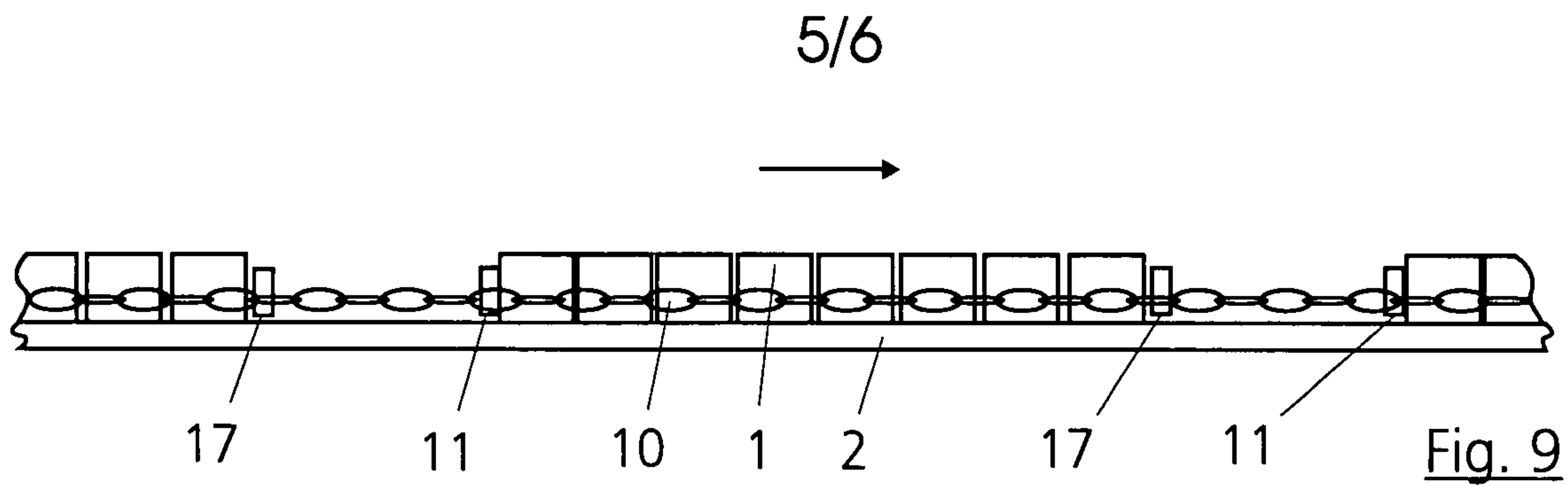

Fig. 8



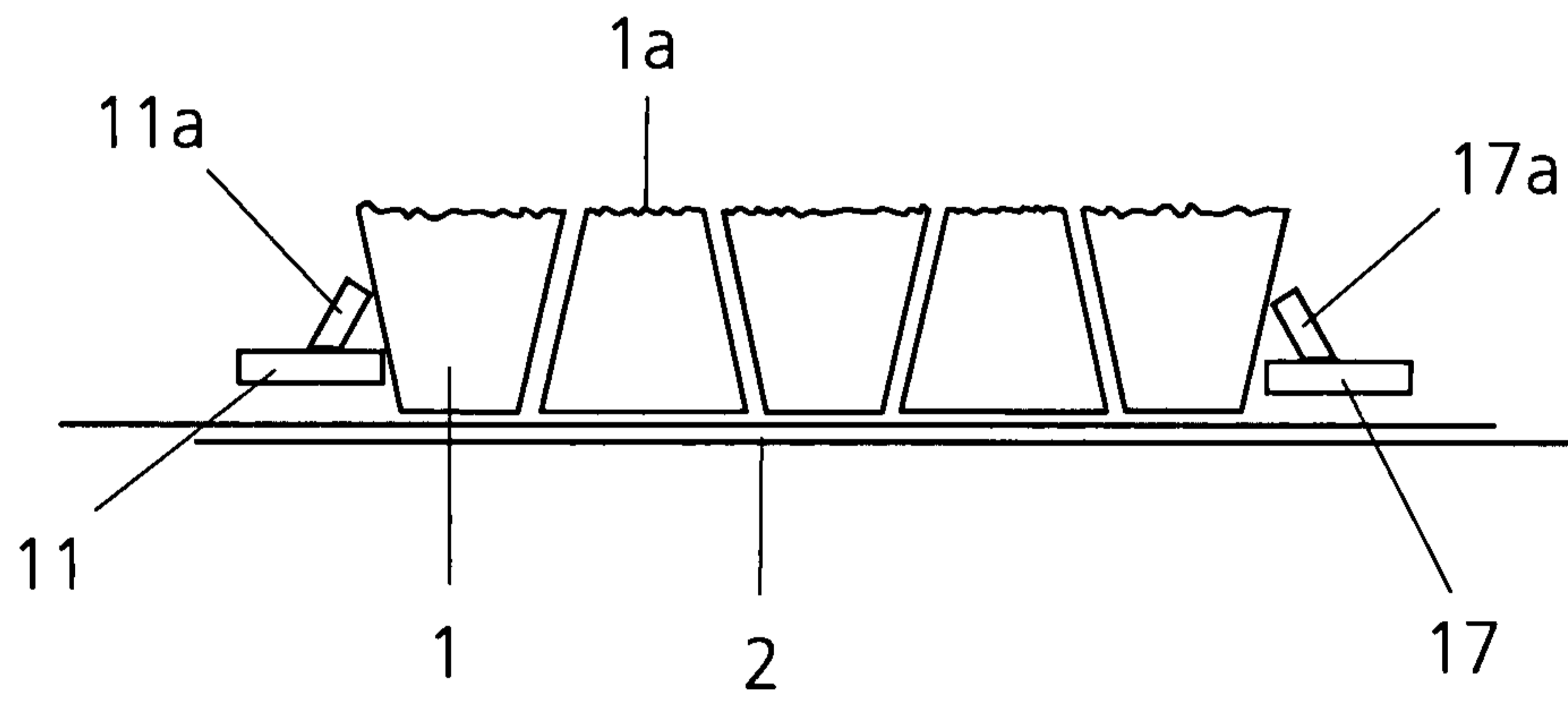

Fig. 13

