



- (51) **International Patent Classification:**
E04F 13/08 (2006.01) *E04B 1/76* (2006.01)
- (21) **International Application Number:**
PCT/GB2016/051895
- (22) **International Filing Date:**
24 June 2016 (24.06.2016)
- (25) **Filing Language:** English
- (26) **Publication Language:** English
- (30) **Priority Data:**
1511292.3 26 June 2015 (26.06.2015) GB
1600576.1 12 January 2016 (12.01.2016) GB
1607808.1 4 May 2016 (04.05.2016) GB
- (71) **Applicant:** SIG PLC [GB/GB]; Hillsborough Works, Langsett Road, Sheffield South Yorkshire S6 2LW (GB).
- (72) **Inventors:** O'KANE, Chris; c/o SIG PLC, Hillsborough Works, Langsett Road, Sheffield South Yorkshire S6 2LW (GB). GRAY, Mark; c/o SIG PLC, Hillsborough Works, Langsett Road, Sheffield South Yorkshire S6 2LW (GB). SMITH, Wayne; c/o SIG PLC, Hillsborough Works, Langsett Road, Sheffield South Yorkshire S6 2LW (GB). MITTON, Paul; c/o SIG PLC, Hillsborough Works, Langsett Road, Sheffield South Yorkshire S6 2LW (GB). ECK-

ERS, Nick; Unit 10 Blenheim Court, Welwyn Garden City Hertfordshire AL7 1AD (GB).

(74) **Agent:** NEILSON, Martin; Urquhart-Dykes & Lord LLP, Tower North Central, Merrion Way, Leeds Yorkshire LS2 8PA (GB).

(81) **Designated States** (*unless otherwise indicated, for every kind of national protection available*): AE, AG, AL, AM, AO, AT, AU, AZ, BA, BB, BG, BH, BN, BR, BW, BY, BZ, CA, CH, CL, CN, CO, CR, CU, CZ, DE, DK, DM, DO, DZ, EC, EE, EG, ES, FI, GB, GD, GE, GH, GM, GT, HN, HR, HU, ID, IL, IN, IR, IS, JP, KE, KG, KN, KP, KR, KZ, LA, LC, LK, LR, LS, LU, LY, MA, MD, ME, MG, MK, MN, MW, MX, MY, MZ, NA, NG, NI, NO, NZ, OM, PA, PE, PG, PH, PL, PT, QA, RO, RS, RU, RW, SA, SC, SD, SE, SG, SK, SL, SM, ST, SV, SY, TH, TJ, TM, TN, TR, TT, TZ, UA, UG, US, UZ, VC, VN, ZA, ZM, ZW.

(84) **Designated States** (*unless otherwise indicated, for every kind of regional protection available*): ARIPO (BW, GH, GM, KE, LR, LS, MW, MZ, NA, RW, SD, SL, ST, SZ, TZ, UG, ZM, ZW), Eurasian (AM, AZ, BY, KG, KZ, RU, TJ, TM), European (AL, AT, BE, BG, CH, CY, CZ, DE, DK, EE, ES, FI, FR, GB, GR, HR, HU, IE, IS, IT, LT, LU, LV, MC, MK, MT, NL, NO, PL, PT, RO, RS, SE, SI, SK,

[Continued on next page]

(54) **Title:** RAINSCREEN CLADDING APPARATUS

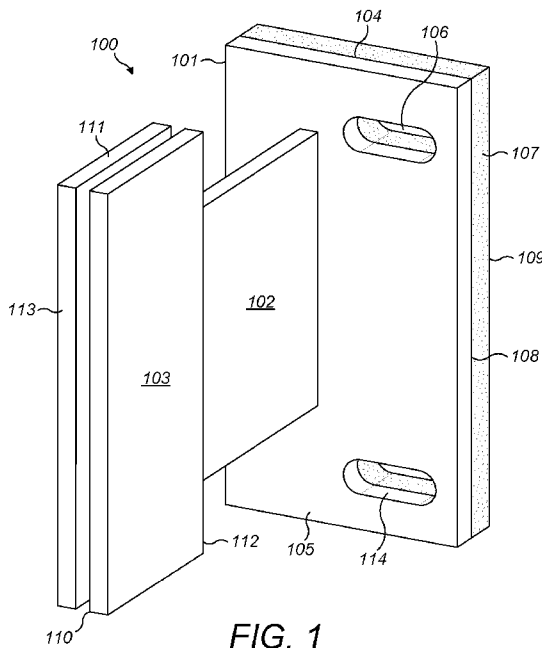

(57) **Abstract:** A bracket to form part of an external panel based cladding system that enhances the thermal isolation between an external cladding layer and an external wall components of a building. In particular the bracket comprises an insulation layer attached to a contact face of a foot part of the bracket in which the insulation layer comprises a conductivity of less than 0.09 W/(m-K). The present bracket is suitable to support external cladding layers as part of cladding system and is attachable to structural boards and timber. The present bracket is also suitable to form part of a steel framing system (SFS).

WO 2016/207648 A1

SM, TR), OAPI (BF, BJ, CF, CG, CI, CM, GA, GN, GQ, GW, KM, ML, MR, NE, SN, TD, TG). **Published:**

— *with international search report (Art. 21(3))*

5

Rainscreen Cladding Apparatus

10

15

Field of invention

The present invention relates to a bracket and cladding apparatus to support cladding
20 panels at an external region of a building and in particular, although not exclusively, to a
bracket and cladding assembly configured to provide an enhanced thermal barrier between
the external cladding and inner components of the assembly positioned closest to the
building.

25 Background art

A common approach to thermally insulate buildings is to apply a ventilated rainscreen
cladding system at the external region of the building. Typically, individual rainscreen
panels are supported on a framework that is attached to the building external wall structure
30 in which the framework is formed from brackets and rails to create an air space between
the external cladding layer and inner leaf components of the framework system (typically
boards). Commonly, the cavity between the external cladding and the inner leaf

components is ventilated to the outside air to prevent entrapment of water and avoid humidity and condensation problems. Where it is required to thermally insulate the building, it is common to include one or more layers of insulation material behind the cladding panels. Accordingly, the external surface structure of the building is concealed
5 from the sun, wind and rain to significantly reduce temperature variations at the external structure and accordingly provide a more controlled external environment of the building that is advantageous for the thermal efficiency management of the building interior.

A variety of different rainscreen panel systems have been proposed in which the external
10 cladding layer is separated from the building external wall structure via sub-frame assemblies, intermediate carrier boards and mounting brackets. Such arrangements are commonly referred to as steel framing systems (SFS). Example disclosures can be found in CA 2820970; WO 2014/204590 and US 2014/0311064. However, existing systems are not optimised with regard to the thermal insulation between the external cladding layer and
15 the external face of the building. In particular, regions of the steel sub-frame and mounting brackets typically provide an effective thermal bridge between the cladding and the external wall that reduces the effectiveness of any intermediate insulation material and the air gap between the cladding layer and the inner leaf boards. Additionally, conventional arrangements are susceptible to fire damage that may undermine significantly the structural
20 integrity of the cladding assembly and compromise secure attachment at the external region of the building. Accordingly, what is required an external cladding arrangement that addresses the above problems.

Summary of the Invention

25

It is an objective of the present invention to provide a rainscreen cladding apparatus configured to enhance the thermal isolation of inner leaf components of an external wall cladding structure for a building from the external environment. It is a further specific objective to provide a mounting assembly having protective external rainscreen cladding
30 panels that reduces the magnitude by which the mounting frame assembly transfers heat between the external cladding layers and the building external wall structure including in

particular inner leaf components including for example cover boards, plaster boards, timber beams and the like.

It is a further specific objective to provide a bracket for a rainscreen cladding apparatus
5 that is resistant to degradation on exposure to fire so as to maintain structural integrity of
the support within the cladding apparatus. It is a specific objective to provide a bracket to
reduce the risk of the cladding apparatus moving appreciably or component parts becoming
detached or lose at the external region of the building. It is a further specific objective to
provide a bracket component for a rainscreen cladding system that is capable of satisfying
10 fire performance standards relating to external wall structures of buildings including in
particular BR 135 and in particular tests BS 8414.

The objectives are achieved by providing a bracket forming part of an external panel based
cladding system that reduces the thermal conduction through the bracket and between the
15 cladding layer and the building wall structure. In particular the objectives are achieved via
configuring the bracket with an insulation layer attached to a contact face of a foot part of
the bracket in which the insulation layer comprises a conductivity of less than 0.09
W/(m·K) at 10°C. The present bracket is suitable to support outermost components of the
external cladding system including in particular external cladding panels to form part of a
20 cladding structure. The present brackets are suitable to form a mounting sub-frame
attachable to the external wall structure that may be formed from cover boards typically
formed from Gypsum or other suitable materials. Additionally, the present bracket is
specifically adapted to form part of a steel framing system (SFS). In particular, the present
bracket is suitable for attachment to intermediate carrier boards that are in turn mounted at
25 the external wall structure via a sub-frame assembly.

According to a first aspect of the present invention there is provided a bracket to form part
of an external building cladding assembly, the bracket comprising: a foot having a contact
face to be positioned to face internally towards the building and attachable to a structural
30 element forming part of the cladding assembly or the building; an attachment element to
attach the bracket to an external cladding panel, an intermediate rail or a mount flange
securable to the cladding panel; an insulation layer attached to the contact face of the foot

to sit intermediate the foot and the structural element; wherein a thermal conductivity of the layer is less than $0.09 \text{ W}/(\text{m}\cdot\text{K})$ at $10 \text{ }^\circ\text{C}$.

Preferably, the attachment element comprises a neck extending perpendicular or transverse
5 from the foot, the neck attachable to an external cladding panel, an intermediate rail or a
mount flange securable to the cladding panel. Optionally, the attachment element
comprises a flange, connector, aperture, bolts, screws and/or fitting configured to be
engaged and to lock with a cooperating element provided at the cladding panel,
intermediate rail or mount flange to connect the bracket to such structures as part of a
10 rainscreen assembly at the building external wall.

The thermal conductivities of the layer material as described herein are stated at room
temperature or a temperature in the range 20 to 27°C , 23 to $27 \text{ }^\circ\text{C}$ and in particular 24 to
 26°C and are stated where the insulation material is provided at a compressive load of
15 13.79 kPa (2psi).

Optionally, the thermal conductivity of the insulation layer is less than 0.05 , 0.04 or 0.03
 $\text{W}/(\text{m}\cdot\text{K})$ at $10 \text{ }^\circ\text{C}$. Optionally, the thermal conductivity of the insulation layer is in the
range 0.002 to $0.06 \text{ W}/(\text{m}\cdot\text{K})$ at $10 \text{ }^\circ\text{C}$. Optionally, the thermal conductivity of the
20 insulation layer is in the range 0.005 to 0.04 ; 0.005 to 0.03 ; 0.01 to 0.03 ; 0.01 to 0.028 or
 0.01 to $0.026 \text{ W}/(\text{m}\cdot\text{K})$ at $10 \text{ }^\circ\text{C}$. Preferably, the insulation layer comprises a silica aerogel
material optionally comprising a fibre coating at a first and/or second surface of the silica
aerogel. Optionally, the insulation may be provided at the bracket as a coating resultant
from a coating process. Optionally the insulation coating is configured to be self-bonding
25 to the contact face of the foot of the bracket without the need for additional bonding agents
or mechanical attachments. Optionally, insulation layer is attached to the contact face of
the foot of the bracket via an adhesive or mechanical attachments.

Optionally, the bracket further comprises a detachable mounting base positionable at the
30 contact face of the foot having a generally planar configuration. Preferably, the mounting
base comprises at least one slot to receive an attachment bolt or the like. Optionally, the
mounting base comprises shoulders projecting upwardly from a mount face, the shoulders

positioned at the corners of the mount face. Optionally, a thickness of the mounting base including the shoulders is less than a thickness the insulation layer such that no part of the shoulders is configured to contact the support substrate to which the insulation layer is attached.

5

Optionally, the insulation layer is formed as a pad and comprises a thermal conductivity that is less than 0.05 W/(m·K) at 10 °C. Optionally, the insulation layer comprises a silica aerogel and a fibre based insulation material having a conductivity in the range 0.01 to 0.05 W/(m·K) at 10 °C. Optionally, the insulation layer comprises: synthetic amorphous silica; methylsilylated silica; polyethylene tetrathalate or polyester; fibrous glass.

10

Optionally, the insulation layer comprises at least one fire retardant component.

Optionally, the fire retardant comprises any one or combination of the set of aluminium hydroxide, aluminium oxide hydroxide, antimony (III) oxide, a clay, a clay within a polymer matrix, an organomodified clay, montmorillonite or compounds or materials including aluminium, phosphorous, nitrogen, antimony, chloride, bromine, magnesium, zinc, a silicate, or calcium silicate.

15

Optionally, the flame retardant comprises iron oxide and/or aluminium trihydrate

(aluminium hydroxide $Al(OH)_3$).

20

Optionally, the insulation layer comprises: silica; a fibrous component preferably fibrous glass; and a flame retardant component. Optionally, the silica is included at 25 to 65% by weight; the fibrous material is included at 35 to 55% by weight and the flame retardant component is included at 1 to 20% by weight.

25

Optionally, the bracket comprises synthetic amorphous silica at 25 to 45% by weight; methylsilated silica at 1 to 25% by weight; fibrous glass at 35 to 55% by weight; iron oxide at 0.5 to 15% by weight; and aluminium trihydrate at 0.5 to 10% by weight.

30

Optionally, the flame retardant component comprises calcium silicate. Optionally, the bracket comprises: synthetic amorphous silica at 25 to 45% by weight; methylsilated silica

at 1 to 25% by weight; fibrous glass at 30 to 50% by weight; calcium silicate at 10 to 25% by weight.

Optionally, the bracket comprises a single insulation layer permanently attached to the
5 foot. Optionally, the insulation layer comprises a thickness in a plane substantially
perpendicular to the foot of between 3 to 15 mm, 5 to 10 mm. Such a thickness is
optimised to provide sufficient thermal isolation between the bracket and an underlying
structure on which the bracket is mounted whilst also maintaining the capability of the
10 bracket to withstand the loading forces transmitted through the cladding assembly due for
example to wind shear and the weight of the various components of the assembly.

Optionally, the bracket may comprise strengthening flanges projecting rearwardly from a
rear face of the foot to enhance the strength characteristics of the bracket to withstand
loading forces. Optionally, the brackets may comprise ribs projecting from a rear face of
the foot with the ribs extending at least partially through the insulation layer that enhance
15 the strength characteristics. Optionally, the flanges or ribs comprise the same or a different
material to the bracket and/or insulation material.

Optionally, the bracket further comprises an adhesive provided between the layer and the
foot such that the layer is non-detachably mounted at the foot. The adhesive may be a
20 thermal bonding agent, an epoxy or other bonding resin.

Optionally, the bracket and in particular the foot and the neck comprise an aluminium or an
aluminium based material.

25 Optionally, the bracket may comprise an adaptor plate positioned intermediate the contact
face of the foot and the insulation layer. Optionally, the adaptor plate may be formed as a
plate or block component releasably mountable to the foot of the bracket. The adaptor
plate may be attached via the same attachment bolts used to attach the bracket to a
substrate board or separate attachments may be provided including bolts, screws, pins,
30 lugs, clips and the like. Optionally, the adaptor plate comprises a thermoplastic material
such as polypropylene. Optionally, a thickness of the adaptor plate is greater than a
thickness of the foot. Optionally, the adaptor plate may comprise a lip extending along a

perimeter of the adaptor plate to sit over and about a perimeter of the foot such that the adaptor plate is configured to overlap onto the foot. Preferably, the adaptor plate is configured such that no part of the foot is positioned in direct contact against the substrate board. The adaptor plate is advantageous to provide structural strength to the bracket by
5 enlarging the footprint and also assist with the thermal isolation between the bracket and the underlying substrate board.

Optionally, the bracket may further comprise a retainer having an open structure to at least partially surround and house the insulation layer, the retainer being releasably attached to
10 the foot. Preferably, the retainer is formed from elongate thin webbing so as to define a cage-like structure. The thickness of the cage material is maintained to a minimum to reduce as far as possible any thermal bridging via the retainer when mounted in position between the bracket and substrate board. Optionally, the retainer is formed as a mesh, gauze, ribbed, webbed or strap-like structure.

15

Preferably, the retainer comprises attachments to releasably attach to the foot or adaptor plate to releasably mount the insulation layer in contact with the foot or the adaptor plate. The attachments may comprise any form of hooks, clips, pins, screws, bolts, adhesive or the like. Preferably, the attachments comprise a plurality of barbed fingers projecting from
20 lengthwise and/or widthwise extending perimeter edges of the retainer.

According to a second aspect of the present invention there is provided a building cladding assembly to form an external wall region of a building comprising: a plurality of cladding panels positionable in an edge-to-edge arrangement to form an external cladding layer of a
25 building; a plurality of brackets as claimed herein, each attachment element of each bracket attachable to one of the cladding panels, an intermediate rail or mount flange securable to the cladding panels, the foot securable to a structural element forming part of the cladding assembly or the building via the respective insulation layers.

30 Optionally, the assembly further comprises cladding rails attachable to the necks of the brackets to form a rail support structure on which to mount the cladding panels. The cladding rails may comprise a head and a tail, with the head extending generally parallel to

the external cladding boards and the tail extending generally parallel to the neck of the bracket.

5 Preferably, the assembly further comprises a plurality of cover boards positionable against timber beams that form a part of an external region of the building, the feet of the brackets attachable to the cover boards via the respective insulation layers. Optionally, the cover boards may comprise acoustic plaster boards and the assembly may comprise a single layer or a plurality of layers of cover boards at the external wall of the building.

10 Optionally, the assembly may comprise a steel frame sub-assembly (SFS) arrangement comprising a sub-frame mountable to a plurality of cover boards positioned to form a part of an external region of the building; a plurality of carrier boards mountable to the sub-frame to provide a sub-cladding layer separated from the cover boards via the sub-frame; and wherein the brackets are mountable to the carrier boards via the respective insulation
15 layers to spatially separate the external cladding layer from the sub-cladding layer.

Optionally, the assembly may comprise a first insulation material positionable between the external cladding layer and the carrier boards. Optionally, the assembly may further comprise a second insulation material positionable between the carrier boards and the
20 cover boards. The insulation material may comprise a fibrous based or mineral based sheet positioned in a gap region between the external cladding panels and the building cover board and/or the region between a carrier board and the building external surface where the system is an SFS cladding assembly.

25 Brief description of drawings

A specific implementation of the present invention will now be described, by way of example only, and with reference to the accompanying drawings in which:

30 Figure 1 is an external perspective view of a bracket forming part of a building cladding assembly to form an external wall region of a building having a low thermal conductivity

material attached to the bracket to reduce thermal conductivity through the cladding assembly according to a specific implementation of the present invention;

Figure 2 illustrates the bracket of figure 1 forming a component part within a building
5 cladding assembly representing an external wall region of a building according to a specific implementation of the present invention;

Figure 3 illustrates the bracket of figure 1 forming part of a building cladding assembly according to a further specific implementation that includes a sub-frame with the brackets
10 mounted on carrier boards positioned intermediate the sub-frame and external cladding panels;

Figure 4 illustrates an adaptor component attachable to a foot part of the bracket to mount a low thermal conductivity layer at the bracket according to a further specific
15 implementation;

Figure 5 is a perspective view of the bracket of figures 1 to 3 according to a further specific implementation having an adaptor component configured for mounting at a foot of the bracket;
20

Figure 6 is a perspective view of the bracket and adaptor of figure 5 attachable to a retainer at least partially housing an insulation layer according to the further specific implementation of figure 5;

25 Figure 7 is an underside perspective view of the retainer and insulation layer of figure 6;

Figure 8 an upper perspective view of the retainer and insulation layer of figure 7.

Detailed description of preferred embodiment of the invention

30

Referring to figure 1 a bracket 100 to form part of a building cladding assembly for cladding an external wall region of a building comprises generally a foot 101, a neck 102

extending generally perpendicular from foot 101 and a head 103 provided at an opposite end of neck 102 relative to foot 101. Foot 101 comprises a generally planar body having a front face 105 and a rear face 104. A pair of elongate slots 106 extend through foot 101 between faces 105, 104 to receive attachment bolts for securing bracket 100 in position
5 within the cladding assembly. Neck 102 projects from front face 105 to separate head 103 from foot 101. According to the specific implementation, foot 101, neck 102 and head 103 are formed integrally from aluminium so as to provide a generally rigid structure. Head 103 comprises a pair of opposed plates 111 that are spatially separated from one another to provide a mouth or gap region 110. One or both plates 111 are hingeably mounted
10 together at rearward edge 112 such that plates 111 may be resiliently separated at edge 113 to increase the size of mouth 110 when mounting a flange or tail part of a rail system that in turn supports external cladding panels.

According to further specific implementations, head 103 may be formed from a single
15 piece or component and comprise apertures to receive mounting bolts, pins, screws etc to secure bracket 100 to a rail or flange supporting the cladding panels. Other head 103 mechanisms may also be envisaged such as bayonet attachments, tongue and groove arrangements, click-lock attachments, push fit connections etc.

20 Bracket 100 further comprises a thermal insulation layer 107 non-detachably mounted at foot rear face 104. According to the specific implementation, the low thermal conductivity pad 107 is attached to rear face 104 via an adhesive such as an epoxy resin. Pad 107 also comprises a pair of elongate slots 114 being dimensioned and positioned to align respectively with the slots 106 (extending through foot 101) to receive attachment bolts.
25 According to the specific implementation, pad 107 comprises a material having a thermal conductivity of 0.010 to 0.030 W/(m·K) at a mean temperature of 23 to 26 °C and as measured as a compressive load of 13.79 kPa. In one implementation, pad 107 comprises Cryogel™ available from Aspen Aerogels, Inc., NA 05132, USA. Pad 107 comprises a thickness in a plane perpendicular to face 104 of 5 mm to 10 mm and incorporates the
30 silica aerogel material and a flexible fibre coating provided at a front face 108 and/or a rear face 109 of pad 107. An epoxy or thermal bonding agent is provided to permanently attach pad 107 via front face 108 to the rear face 104 of foot 101.

Referring to figure 2, bracket 100 is suitable for inclusion within an external rainscreen cladding system that is configured as an external wall structure of a building. The building interior is defined by an acoustic plaster board 215 that represents an inner leaf of the system having a rear face 217 that is internal facing within the building. Timber studs (beams) 204 are, in turn, mounted to an external facing mount face 216 of plaster board 215. A composite board 203 is secured to a front face 212 of timber studs 204 via a rear face 213. Accordingly, composite board 203, studs 204 and plaster board 215 represent inner leaf components of the external wall structure that may be regarded as an external wall of the building. A plurality of the brackets 100 are secured directly to a mount face 211 of composite boards 203 (alternatively termed cover boards) via mating contact with pad rear face 109. Each bracket 100 is secured to each cover board 203 via attachment bolts 200 that extend through foot 101 having bolt heads 201 positioned against front face 105. Accordingly, foot 101 is thermally isolated from cover board 203 via pad 107. Each bracket head 103 is secured to a tail member 206 that forms a rearward part of a panel mounting rail assembly 205. In particular, tail member 206 is formed as an elongate plate at least partially received within mouth 110 between bracket plates 111 so as to be gripped by frictional contact to securely mount rail 205 at brackets 100. Accordingly, tail member 206 is aligned generally parallel with bracket plates 111 and neck 102 and generally perpendicular to foot 101, insulation pad 107 and cover board 203. A rail head 207 also extends perpendicular to tail member 206. Rail head 207 comprises a mount face 214 for positioning in contact and attachment to a rear face 209 of a plurality of cladding panels 208. Each panel 208 comprises an external face 210 that represents an external-most part of the cladding assembly. Due to the respective lengths of bracket neck 102, head 103 and tail member 206, a spatial gap 202 is created between cover board 203 and cladding panels 208. According to a further embodiment, a sheet insulation material may be positioned in the gap region 202 between cover board mount face 211 and external cladding panel rear face 209 to enhance the thermal partitioning of external cladding panels 208 and boards 203 and 215.

30

Bracket insulation pad 107 is effective to minimise the thermal conductivity from the external cladding panels 208 to the cover board 203 at the region immediately behind foot

101. That is, the region of foot rear face 104 would otherwise provide a thermal bridge to between panels 208 and cover boards 203. By utilising pad 107 of a low thermal conductivity material, bracket 100 thermally isolates the inner leaf plaster board 215. To further enhance thermal isolation, suitable low thermal conductivity washers or flanges
5 may be provided under bolt heads 201 to thermally isolate bolts 200, 201 from the metallic foot 101.

Figure 3 illustrates a further embodiment of the present invention forming part of a steel framing system (SFS) cladding assembly. According to the further embodiment, the
10 building external wall is, in part, defined by a sub-frame assembly that comprises an innermost plaster board 215 as described with reference to figure 2 representing an innermost component of the assembly. According to the arrangements of figures 2 and 3, a plurality of boards 215 may be provided as the innermost components of the assembly to provide acoustic insulation in addition to enhanced thermal insulation. The sub-frame
15 assembly comprises a plurality of lightweight steel frame support members 300 attached directly to mount face 216 of plaster board 215. Cover boards 203 (alternatively termed a carrier boards) are mounted at an opposite side of the support members 300 via carrier board rear face 213. Accordingly, a spatial gap 304 is created between carrier boards rear face 213 and plaster boards mount face 216. A plurality of brackets 100 are then attached
20 to a front face 211 of carrier boards 203 via contact between rear face 109 of insulation pad 107 and carrier board front face 211 as detailed with reference to figure 2. Accordingly, carrier boards 203 are positioned intermediate brackets 100 and steel frame support members 300. The external-most layer of cladding panels 208 are mounted at the brackets 100 via the rail assembly 205 as described with reference to figure 2. Also, according to
25 the further specific implementation, brackets 100 are secured to carrier board 203 via the same bolts 200, 201 as described with reference to figure 2. According to further embodiments, bolts 200, 201 may be configured to extend through carrier boards 203 and into respective steel frame support members 300. As will be appreciated, frame support members 300 may be attached to carrier boards 203 via respective attachment bolts,
30 screws, pins etc. As with the embodiments of figure 2, should it be required to enhance the thermal isolation between cladding panels 208 and plaster board 215, a first layer of insulation material (not shown) may be positioned within gap region 202 and layered onto

front face 211 of carrier boards 203. Additionally, a second layer of insulation material (not shown) may be positioned within gap region 304 in contact between carrier board rear face 213 and/or cover board mount face 216.

- 5 According to the embodiments of figures 1 to 3, the present bracket assembly 100 is advantageous via the low thermal conductivity of pad 107 to provide a rainscreen cladding assembly of reduced total thickness between inner leaf board 215 and cladding panels 208.

In one implementation and referring to figure 4 pad 107 may be attached to bracket 100 via
10 an intermediate adaptor indicated generally by reference 400. Adaptor 400 comprises a generally planar base 401 having an underside surface 402 and a support surface 403. Underside surface 402 is configured for positioning against and in contact with rear face 104 of foot 101 and comprises slots 405 positioned and dimensioned to correspond to slots 106 to receive attachment bolts so as to anchor bracket 100 to a suitable support substrate
15 (i.e., boards 203). Base 401 comprises four shoulders 404 positioned at each corner 406 of base 401 that project upwardly a relatively short height/distance from support surface 403.

Each shoulder 404 is formed as a relatively thin border section projecting from each corner 406 and extending a short lengthwise and widthwise distance along a part of the perimeter
20 edge that defines support surface 403. A thickness of each shoulder 401 in the plane of support surface 403 is significantly less than a thickness of base 401 in a plane perpendicular to the plane of support surface 403. Accordingly, should any one of the shoulders 404 contact the substrate to which pad 107 is attached (for example under extreme compression) any thermal bridging effect through shoulders 404 is minimised and
25 may be regarded as negligible. Shoulders 404 are configured to facilitate mounting of pad 107 on support surface 403 and are not intended to provide structural support and in particular to enhance the surface area contact between the bracket and the substrate board 203. The present bracket is constructed such that the pad rear face 109 provides exclusively the contact of the bracket 100 onto the support substrate 203 so as to maximise
30 the thermal isolation function of the present bracket 100. Base 401 and in particular support surface 403 is configured to support pad 107 (illustrated with dashed lines) with pad 107 having a footprint or surface area corresponding to that of support surface 403 and

the rear face 104 of bracket 100. The height of each shoulder 404 is appreciably less than a thickness of pad 107 (in the plane perpendicular to the plane of support surface 403) such that even under compression, pad 107 provides the exclusive contact and intermediate coupling between the support substrate 203 and the foot 101. That is under normal loading conditions, no part of each shoulder 404 is capable of contacting the support substrate.

A further specific implementation of the bracket and adaptor of figures 1 to 4 is detailed according to figures 5 to 8. According to the further implementation, bracket 100 comprises the same features as described with reference to figure 1 including for example but not limited to the foot 101, neck 102, head 103 and associated components and features. According to the further specific implementation, an adaptor plate 500 is formed from a polypropylene thermoplastic and comprises a support surface 501 for positioning in contact against the rear face 104 of foot 101. Adaptor plate 500 also comprises an opposed underside surface 502 for positioning against insulation layer 107. As described with reference to figure 4, a plurality of elongate slots 503 are formed through plate 500 between the opposed faces 501, 502. Plate 500 also comprises a raised edge 504 in the form of a lip or step extending around a perimeter of plate 500 along the lengthwise and widthwise extending perimeter edges. Plate 500 and edges 504 are dimensioned to sit over and about foot 101 such that foot 101 is at least partially housed within the recess defined by the upstanding adaptor plate edges 504. Elongate slots 503 are dimensioned so as to be co-aligned with slots 114 extending through foot 101 such that plate 500 is capable of being releasably mountable at foot 101 via the attachment bolts 200.

Referring to figures 6 to 8, bracket 100 also comprises a retainer indicated generally by reference 600. Retainer 600 comprises an open or cage-like structure to at least partially house pad 107 within an internal region indicated generally by reference 605. Region 605 is defined by a plurality of interconnect elongate struts that collectively define a containing frame having the cage-like structure. In particular, a set of lengthwise and widthwise extending struts 604b define a perimeter footprint of the retainer 600 with the lengthwise and widthwise struts 604b connected via corner struts 604c that together define a cuboidal open cage structure defining internal cavity region 605. The structure is supported by a set of bracing struts 604a that extend between struts 604b and across side faces of the retainer

600 and a rear face 800. An opposed contact face 801 of retainer 600 is generally open and is not obstructed by support struts 604a. Accordingly, with pad 107 located within cavity 605, the majority and in particular at least 80 or 90%, of the planar pad front face 108 is exposed for contact against the underside surface 502 of adaptor plate 500.

5 Accordingly, when retainer 600 is mounted in position and in contact against adaptor plate 500, the underside rear face 109 of pad 107 is largely exposed for contact against the cover board 203 when bracket 100 is mounted in position within the external rainscreen cladding system as described referring to figures 2 and 3.

10 Retainer 600 is releasably mountable at adaptor plate 500 via a set of attachment clips that project from retainer contact face 801. In particular, retainer 600 and in particular lengthwise and widthwise extending struts 604b comprises fingers 602 that project outward from and perpendicular to front face 108. Each finger 602 comprises a barb 603 directed inwardly towards pad front face 108. The length of each finger 602 is greater than
15 a thickness of adaptor plate 500 so as to allow barbs 603 to be resiliently biased against and to hook over the raised adaptor plate edges 504 at plate face 501. Accordingly, with pad 107 housed within the cage-like retainer 600, pad 107 may be releasably clipped into contact with the bracket 100 via the mating of the retainer 600 onto adaptor plate 500 that is in turn secured to foot 101.

20

The configuration of figures 5 to 7 is advantageous to provide thermal isolation of bracket 100 and composite board 203 via the intermediate positioned adaptor plate 500 and pad 107. Adaptor plate 500 also assists with the thermal isolation of bracket 100 and board 203 by providing an additional body of relatively low thermal conductivity between
25 bracket 100 and board 203. The configuration of adaptor plate 500 and retainer 600 and in particular the cage-like structure of retainer 600 is advantageous to impart sufficient structural strength to the insulation layer 107 and to avoid loading induced deflection of the insulation layer assembly when mounted in position within a rainscreen system of figures 2 to 3. That is, the retainer 600 and the adaptor plate 500 when coupled together are capable
30 of transmitting load from the bracket 100 to the board 203 via attachment bolts 200.

Accordingly, the subject invention is advantageous to provide both the desired structural

attachment strength whilst achieving the desired thermal isolation of the various components of the rainscreen system of figures 2 to 3.

5 Example materials of the thermal isolating pad 107 are detailed below. The following examples are not limiting and the subject invention includes other alternative specific implementations having constituent materials that differ from those indicated. The relative concentrations of the constituent materials may also be selected to suit specific applications.

10 Example 1

Pad 107 comprises a material composition comprising components having thermal insulation characteristics including in particular silica particulate based materials. Preferably, the material of pad 107 comprises at least one fibrous component. According to the example 1, pad 107 comprises a foil cover provided at one or both faces. The constituents of the material of pad 107 according to example 1 are detailed in table 1.

Chemical name	CAS No.	Concentration wt %
Synthetic Amorphous Silica	7631-86-9	25-40%
Methylsilylated Silica	68909-20-6	10-20%
Polyethylene terephthalate (PET or polyester)	25038-59-9	10-20%
Fibrous Glass (textile grade)	-	10-20%
Magnesium Hydroxide	1309-42-8	0-5%
Aluminium Foil	7429-90-5	0-5%

Table 1 – composition of pad 107 comprising Cryogel™ Z available from Aspen Aerogels, Inc., MA 01532, USA.

Bracket 100 comprising pad 107 according to the subject invention is advantageous to provide thermal performance enhancement over existing bracketry arrangements. The thermally isolating characteristic of the subject bracket 100 is achieved, in part, as the contact surface area of pad rear face 109 is at least equal to or greater than rear face 104 of

foot 101 such that no part of foot 101 is capable of contacting the support substrate onto which bracket 100 is mechanically attached. Additionally, due to the aerogel and fibrous composite material, pad 107 is capable of compression in use as bracket 100 is secured to the support substrate (board 203) via attachment bolts 200 without any reduction in the thermal conductivity resistance of pad 107.

The present pad 107 is further advantageous to provide the desired structural performance and in particular to withstand shear and torsional forces transmitted through bracket 100 when bracket 100 is installed within an external cladding system according to figures 2 and 3. That is, bracket 100 due to the choice of material of pad 107 is not configured to deflect appreciably in a vertical plane due to shear loading and also not to twist about its longitudinal axis due to torsional forces. Bracket 100 achieves the desired minimal deflection during use as it comprises a single pad only mounted at one end of the bracket. In one implementation, the pad comprises a density in a range 0.16 g/cm^3 to 0.2 g/cm^3 .

15

Example 2

In some specific implementations and under example 2, pad 107 comprises at least one fire retardant component. According to example 2, pad 107 further comprises a material composition comprising silica particulate based components having thermal insulation characteristics and at least one fibrous component including for example fibrous glass.

Where the pad 107 comprises a fire retardant composition, the fire retardant may comprise a metal oxide, a metal hydroxide, aluminium hydroxide, aluminium oxide, aluminium oxide hydroxide, or compounds including aluminium, phosphorous, nitrogen, antimony, chlorine, bromine, magnesium or zinc. Optionally, the fire retardant comprises a clay within a polymer matrix including at least one organomodified clay. Optionally, the clay comprises a montmorillonite. In some implementations, the fire retardant component comprises an inorganic compound such as antimony (III) oxide (Sb_2O_3). The constituents of the material of pad 107 according to example 2 are detailed in table 2.

30

Chemical name	CAS No.	Concentration wt %
Synthetic Amorphous Silica	7631-86-9	30-40%
Methylsilylated Silica	68909-20-6	10-20%
Fibrous Glass (textile grade)	Not Applicable	40-50%
Iron Oxide (iron (III) oxide)	1309-37-1	1-10%
Aluminium Trihydrate (aluminium hydroxide)	21645-51-2	1-5%
Optional additional components	-	Balance

Table 2 – Composition of pad 107 comprising Pyrogel™ XT-E available from Aspen Aerogels, Inc., MA 01532, USA.

5

In specific implementations, pad 107 is configured to withstand high temperature environment typically associated with a fire. Preferably, the fire retardant is included at a concentration of 1 to 20% by weight. The flame retardant is configured to provide a pad 107 that does not disintegrate or decompose when exposed to temperatures of up to 650 °C.

10 Accordingly, in such implementations, bracket 100 is configured to exhibit no or only minor deflection under loading (as would typically be encountered when bracket 100 is mounted within the cladding systems of figures 2 and 3) during and following exposure to fire. Accordingly, the structural integrity of the external cladding systems of figures 2 and 3 is maintained even in the event of a fire at the external cladding assembly enabling
 15 bracket 100 to satisfy further international standards such as EN 13501 (BR 135) – *Fire Performance of External Thermal Insulation for Walls of Multistorey Buildings*. In particular the present bracket 100 comprising a material of example 2 (Pyrogel™) is capable of satisfying the (BR 135) BS 8414 and EN 1364-1/2 test criteria. According to example 2, pad 107 does not comprise a foil cover provided at one or both faces.

20

Example 3

Example 3 is a variation of example 2 in which pad 107 comprises at least one fire retardant component in addition to comprising silica particulate based components having

thermal insulation characteristics and at least one fibrous component including for example fibrous glass.

The fire retardant may comprise a silicate, belite, calcium monosilicate, calcium hydrosilicate, calcium metasilicate, calcium orthosilicate, grammite, or Ca_2SiO_4 . The constituents of the material of pad 107 according to example 3 are detailed in table 3.

Chemical name	CAS No.	Concentration wt %
Synthetic Amorphous Silica	7631-86-9	30-40%
Methylsilylated Silica	68909-20-6	5-15%
Fibrous Glass (textile grade)	Not Applicable	35-45%
Calcium Silicate	13983-17-0	15-20%

Table 3 – Composition of pad 107 comprising Spaceloft™ A2 available from Aspen Aerogels, Inc., MA 01532, USA.

In specific implementations, pad 107 is configured to withstand high temperature environment typically associated with a fire. Preferably, the fire retardant is included at a concentration of 1 to 30% by weight. The flame retardant is configured to provide a pad 107 that does not disintegrate or decompose when exposed to temperatures of up to 650 °C. Accordingly, in such implementations, bracket 100 is configured to exhibit no or only minor deflection under loading (as would typically be encountered when bracket 100 is mounted within the cladding systems of figures 2 and 3) during and following exposure to fire. Accordingly, the structural integrity of the external cladding systems of figures 2 and 3 is maintained even in the event of a fire at the external cladding assembly enabling bracket 100 to satisfy further international standards such as EN 13501 (BR 135) – *Fire Performance of External Thermal Insulation for Walls of Multistorey Buildings*. In particular the present bracket 100 comprising a material of example 3 (Spaceloft™) is capable of satisfying the (BR 135) BS 8414, and EN 1364-1/2 test criteria as an A2 rating and ASTM E 84 fire test as a Class A rating. According to example 3, pad 107 does not comprise a foil cover provided at one or both faces.

The present fire retardant pad 107 according to examples 2 and 3 is advantageous to withstand shear and torsional forces transmitted through bracket 100 (when mounted within an external cladding system according to figures 2 and 3) and not to deflect appreciably in a vertical plane due to shear loading and also not to twist about its longitudinal axis due to torsional forces during and after exposure fire at high temperatures of up to 650 °C. Such a configuration is achieved as the pad 107 does not disintegrate and maintains substantially its pre-fire physical and mechanical characteristics and composition.

Claims

1. A bracket to form part of an external building cladding assembly, the bracket comprising:
 - 5 a foot having a contact face to be positioned to face internally towards the building and attachable to a structural element forming part of the cladding assembly or the building;
 - an attachment element to attach the bracket to an external cladding panel, an intermediate rail or a mount flange securable to the cladding panel;
 - 10 an insulation layer attached to the contact face of the foot to sit intermediate the foot and the structural element;
 - wherein a thermal conductivity of the layer is less than $0.09 \text{ W}/(\text{m}\cdot\text{K})$ at $10 \text{ }^\circ\text{C}$.
2. The bracket as claimed in claim 1 when the thermal conductivity is less than 0.05
15 $\text{W}/(\text{m}\cdot\text{K})$ at $10 \text{ }^\circ\text{C}$.
3. The bracket as claimed in claim 1 when the thermal conductivity is less than 0.03
 $\text{W}/(\text{m}\cdot\text{K})$ at $10 \text{ }^\circ\text{C}$.
- 20 4. The bracket as claimed in claim 1 when the thermal conductivity is in the range 0.01 to $0.03 \text{ W}/(\text{m}\cdot\text{K})$ at $10 \text{ }^\circ\text{C}$.
5. The bracket as claimed in any preceding claim wherein the insulation layer comprises a fibre based insulation material.
25
6. The bracket as claimed in any preceding claim wherein the insulation layer comprises a silica aerogel.
7. The bracket as claimed in any preceding claim wherein the insulation layer
30 comprises a fibrous component.

8. The bracket as claimed in any preceding claim wherein the insulation layer comprises:

- synthetic amorphous silica;
- methylsilylated silica;
- 5 • polyethylene tetrathalate or polyester;
- fibrous glass.

9. The bracket as claimed in any one of claims 1 to 7 wherein the insulation layer comprises at least one fire retardant component.

10

10. The bracket as claimed in claim 9 wherein the fire retardant comprises any one or combination of the set of aluminium hydroxide, aluminium oxide hydroxide, antimony (III) oxide, a clay, a clay within a polymer matrix, an organo modified clay, montmorillonite or compounds or materials including aluminium, phosphorous, nitrogen, antimony, chloride, bromine, magnesium, zinc, a silicate, or calcium silicate.

15

11. The bracket as claimed in any one of claims 1 to 7 wherein the insulation layer comprises:

- silica;
- 20 • a fibrous component preferably fibrous glass;
- a flame retardant component.

12. The bracket as claimed in claim 11 wherein the flame retardant comprises iron oxide and/or aluminium trihydrate (aluminium hydroxide $\text{Al}(\text{OH})_3$).

25

13. The bracket as claimed in claim 12 wherein the silica is included at 25 to 65% by weight; the fibrous material is included at 35 to 55% by weight and the flame retardant component is included at 1 to 20% by weight.

30 14. The bracket as claimed in 13 comprising:

- synthetic amorphous silica at 25 to 45% by weight;
- methylsilated silica at 1 to 25% by weight;

-23-

- fibrous glass at 35 to 55% by weight;
- iron oxide at 0.5 to 15% by weight; and
- aluminium trihydrate at 0.5 to 10% by weight.

5 15. The bracket as claimed in 11 wherein the flame retardant component comprises calcium silicate.

16. The bracket as claimed in 15 comprising:

- synthetic amorphous silica at 25 to 45% by weight;
- 10 • methylsilated silica at 1 to 25% by weight;
- fibrous glass at 30 to 50% by weight;
- calcium silicate at 10 to 25% by weight.

17. The bracket as claimed in any preceding claim wherein the insulation layer
15 comprises a thickness in a plane substantially perpendicular to the foot of between 3 to 15 mm.

18. The bracket as claimed in any preceding claim further comprising an adhesive
20 provided between the layer and the foot such that the layer is non-detachably mounted at the foot.

19. The bracket as claimed in any preceding claim wherein the attachment element
comprises a neck extending perpendicular or transverse from the foot, the neck attachable
to an external cladding panel, an intermediate rail or a mount flange securable to the
25 cladding panel

20. The bracket as claimed in claim 19 wherein the foot and the neck comprise
aluminium or an aluminium based material.

30 21. The bracket as claimed in any preceding claim comprising a single insulation layer permanently attached to the foot.

22. The bracket as claimed in any preceding claim further comprising an adaptor plate positioned intermediate the contact face of the foot and the insulation layer.
23. The bracket as claimed in claim 22 wherein the adaptor plate comprises a
5 thermoplastic material.
24. The bracket as claimed in claims 22 or 23 wherein a thickness of the adaptor plate is greater than a thickness of the foot.
- 10 25. The bracket as claimed in any one of claims 22 to 24 wherein the adaptor plate comprises a lip extending along a perimeter of the adaptor plate to sit over and about a perimeter of the foot such that the adaptor plate is configured to overlap onto the foot.
26. The bracket as claimed in any preceding claim further comprising a retainer
15 having an open structure to at least partially surround and house the insulation layer, the retainer being releasably attached to the foot.
27. The bracket as claimed in claim 26 when dependent on claim 22 wherein the
20 retainer comprises attachments to releasably attach to the foot or adaptor plate to releasably mount the insulation layer in contact with the foot or the adaptor plate.
28. The bracket as claimed in claim 27 wherein the attachments comprise a plurality
of barbed fingers projecting from lengthwise and/or widthwise extending perimeter edges
of the retainer.
25
29. The bracket as claimed in any one of claims 26 to 28 wherein the retainer
comprises a cage-like structure.
30. A building cladding assembly to form an external wall region of a building
30 comprising:
a plurality of cladding panels positionable in an edge-to-edge arrangement to form
an external cladding layer of a building;

a plurality of brackets as claimed in any preceding claim, each attachment element of each bracket attachable to one of the cladding panels, an intermediate rail or mount flange securable to the cladding panels, the foot securable to a structural element forming part of the cladding assembly or the building via the respective insulation layers.

5

31. The assembly as claimed in claim 30 further comprising cladding rails attachable to the attachment elements of the brackets to form a rail support structure on which to mount the cladding panels.

10 32. The assembly as claimed in claim 31 further comprising a plurality of cover boards positionable against timber beams that form a part of an external region of the building, the feet of the brackets attachable to the cover boards via the respective insulation layers.

15 33. The assembly as claimed in claims 30 to 31 further comprising:
a sub-frame mountable to a plurality of cover boards positioned to form a part of an external region of the building;

a plurality of carrier boards mountable to the sub-frame to provide a sub-cladding layer separated from the cover boards via the sub-frame; and

20 wherein the brackets are mountable to the carrier boards via the respective insulation layers to spatially separate the external cladding layer from the sub-cladding layer.

34. The assembly as claimed in claim 33 further comprising a first insulation material
25 positionable between the external cladding layer and the carrier boards.

35. The assembly as claimed in claim 34 further comprising a second insulation material positionable between the carrier boards and the cover boards.

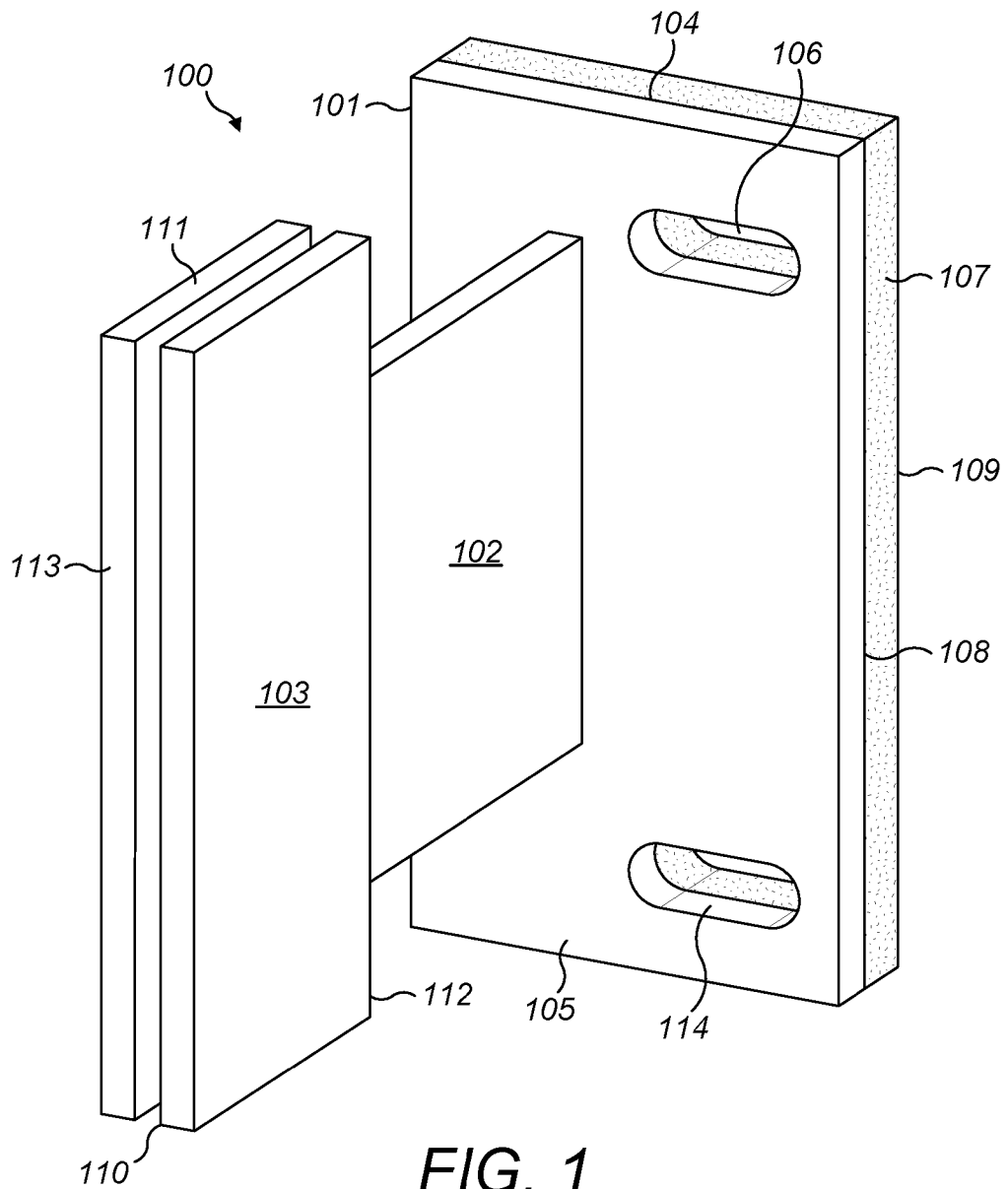

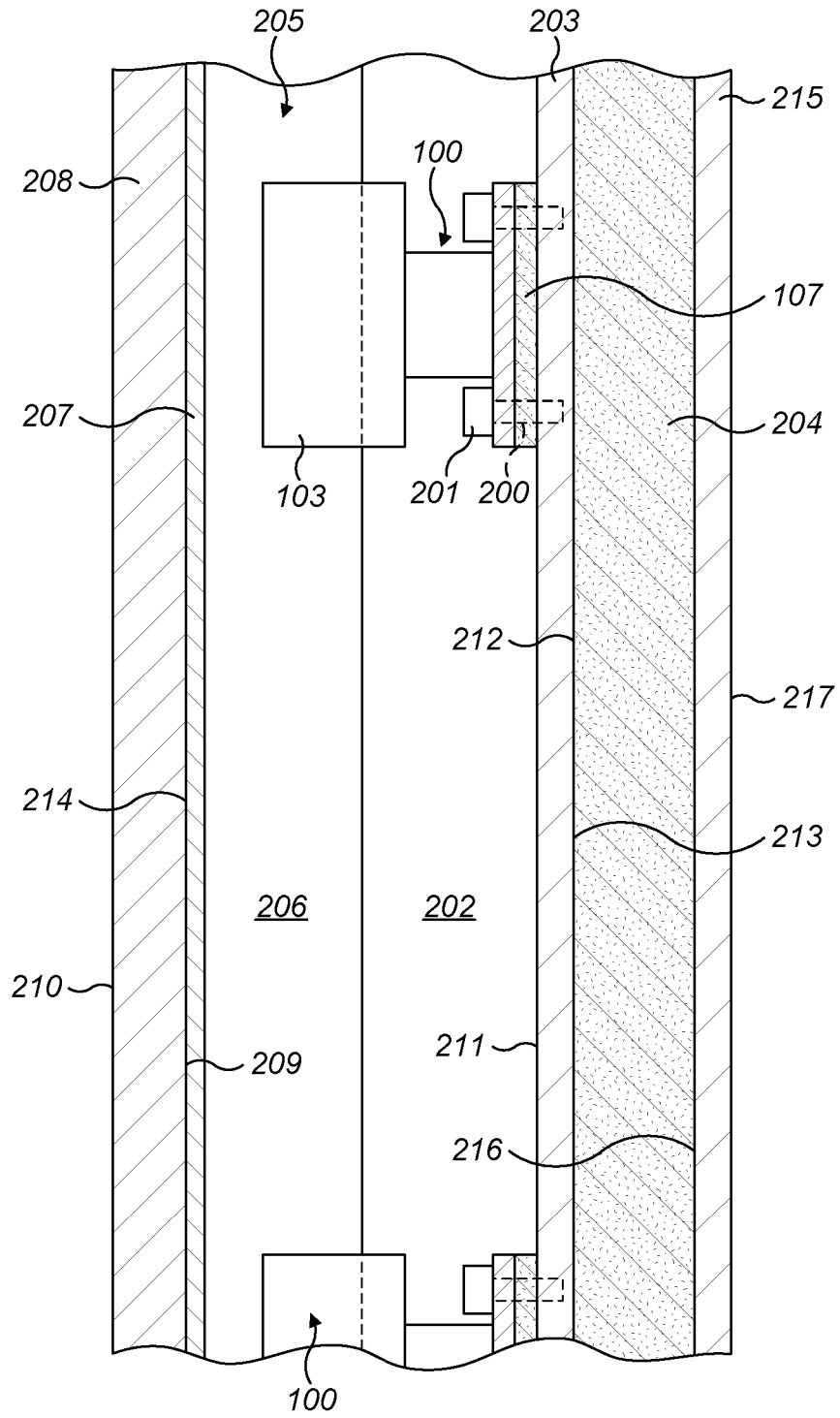

FIG. 2

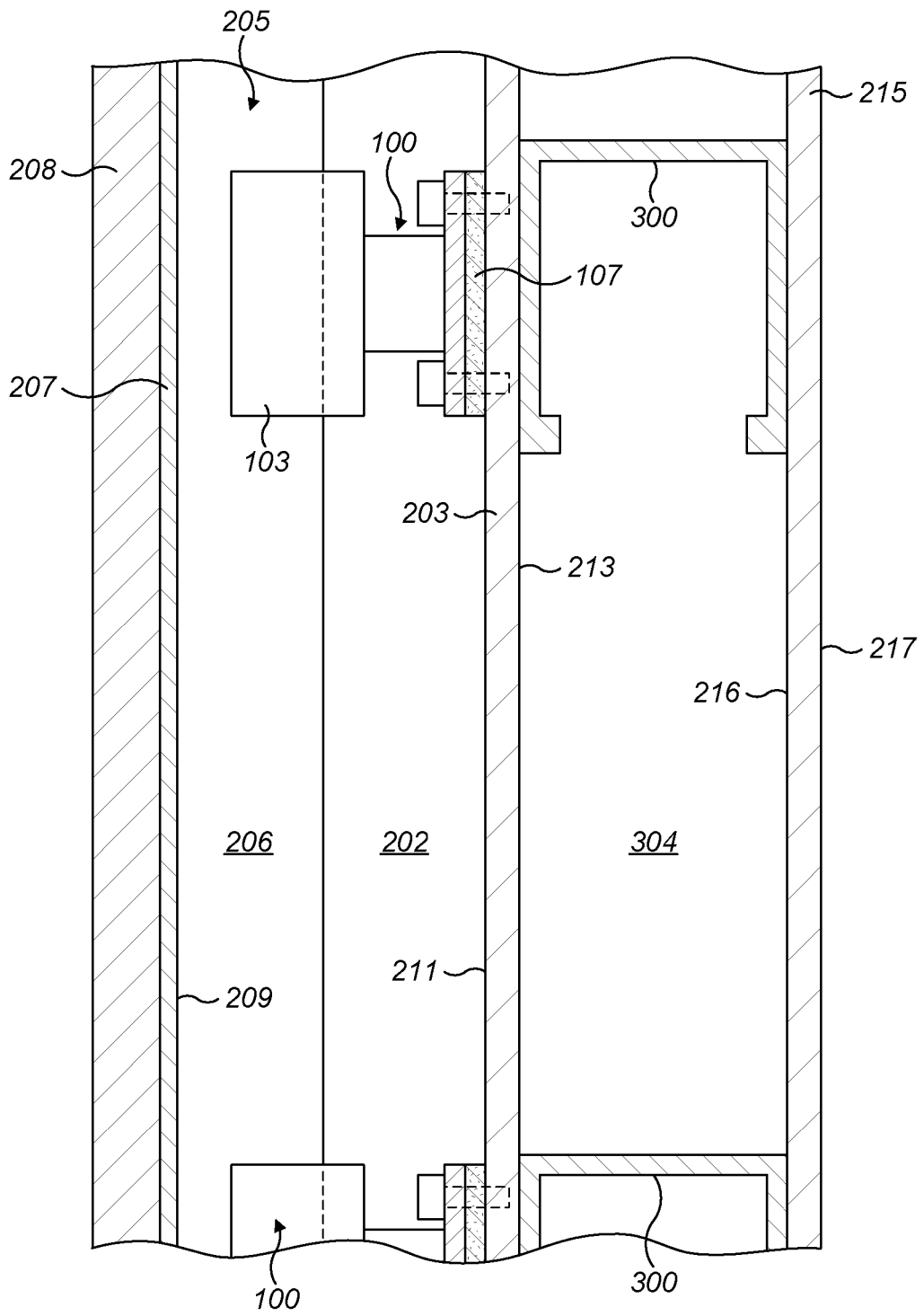

FIG. 3

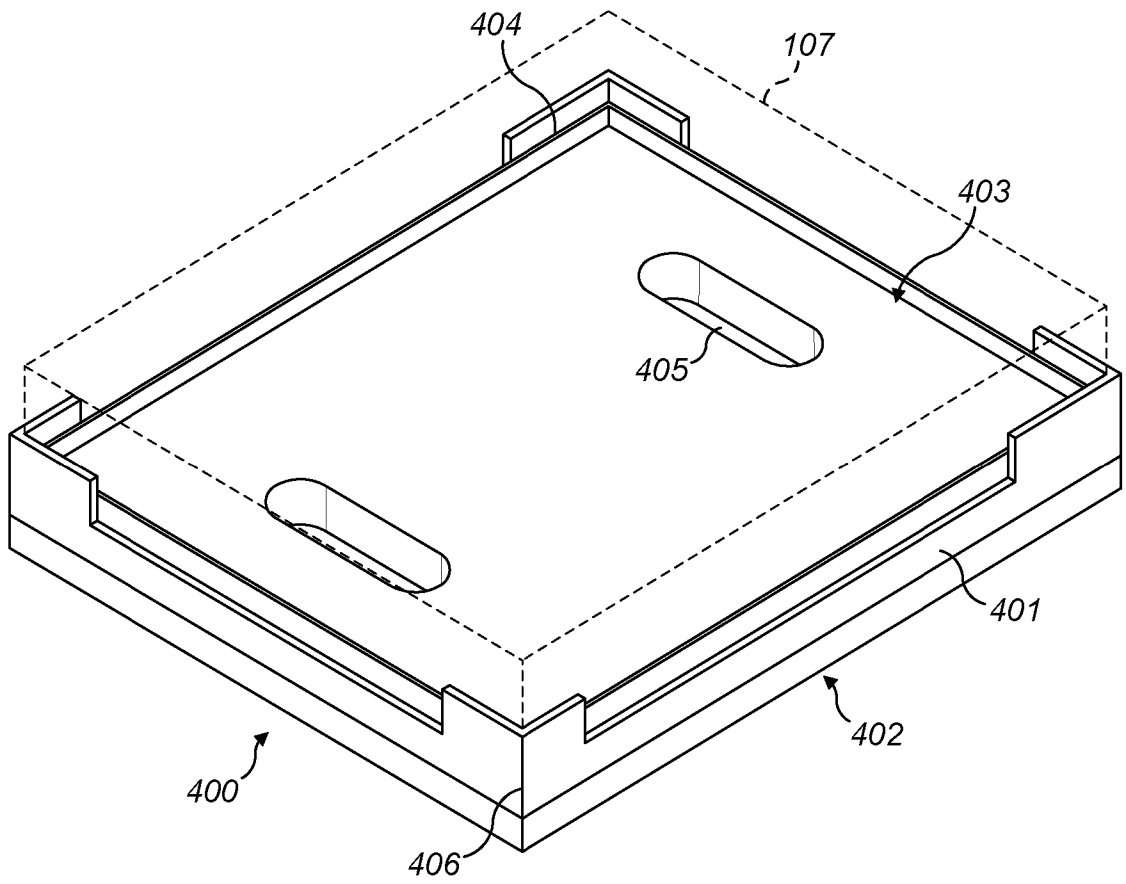

FIG. 4

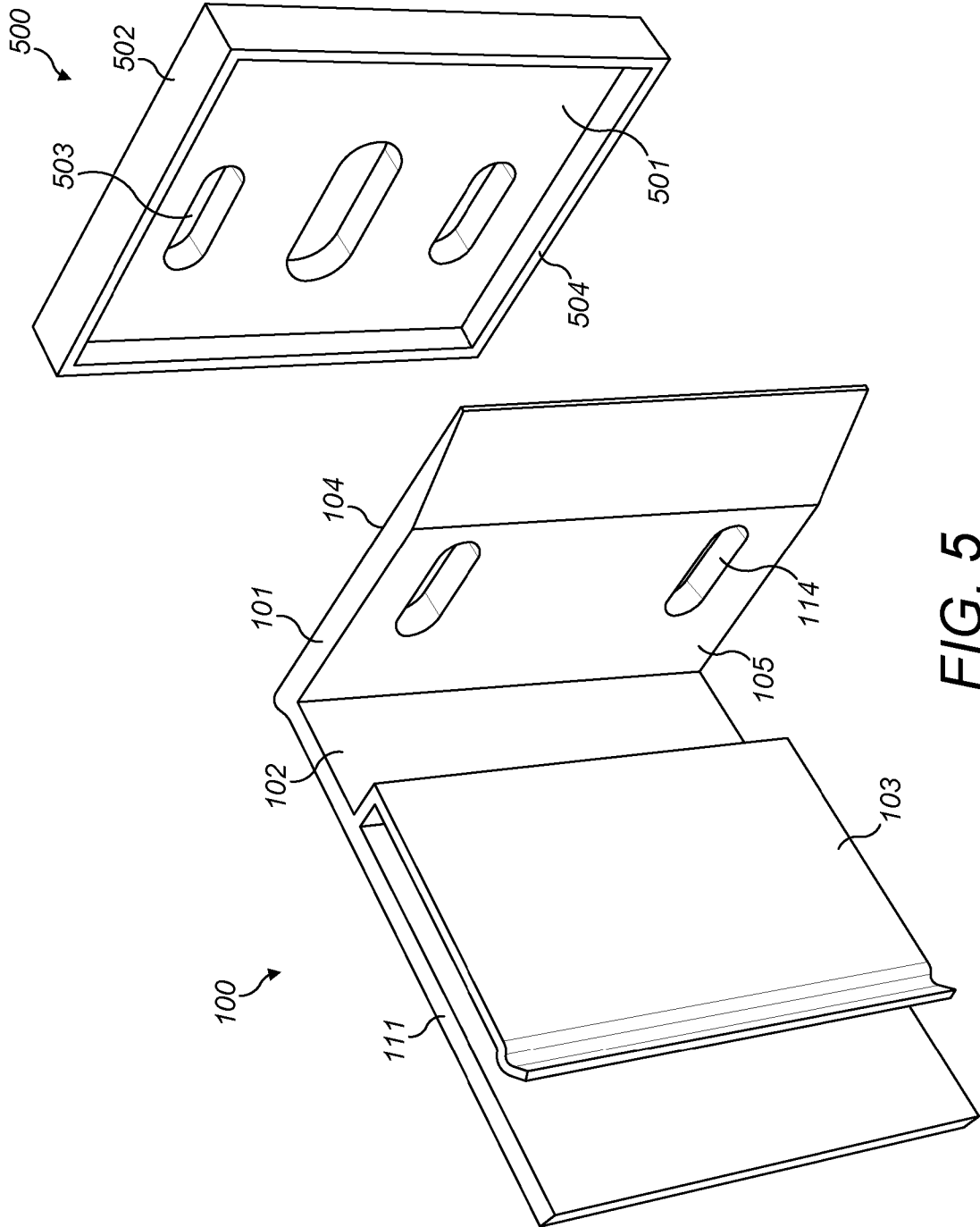

FIG. 5

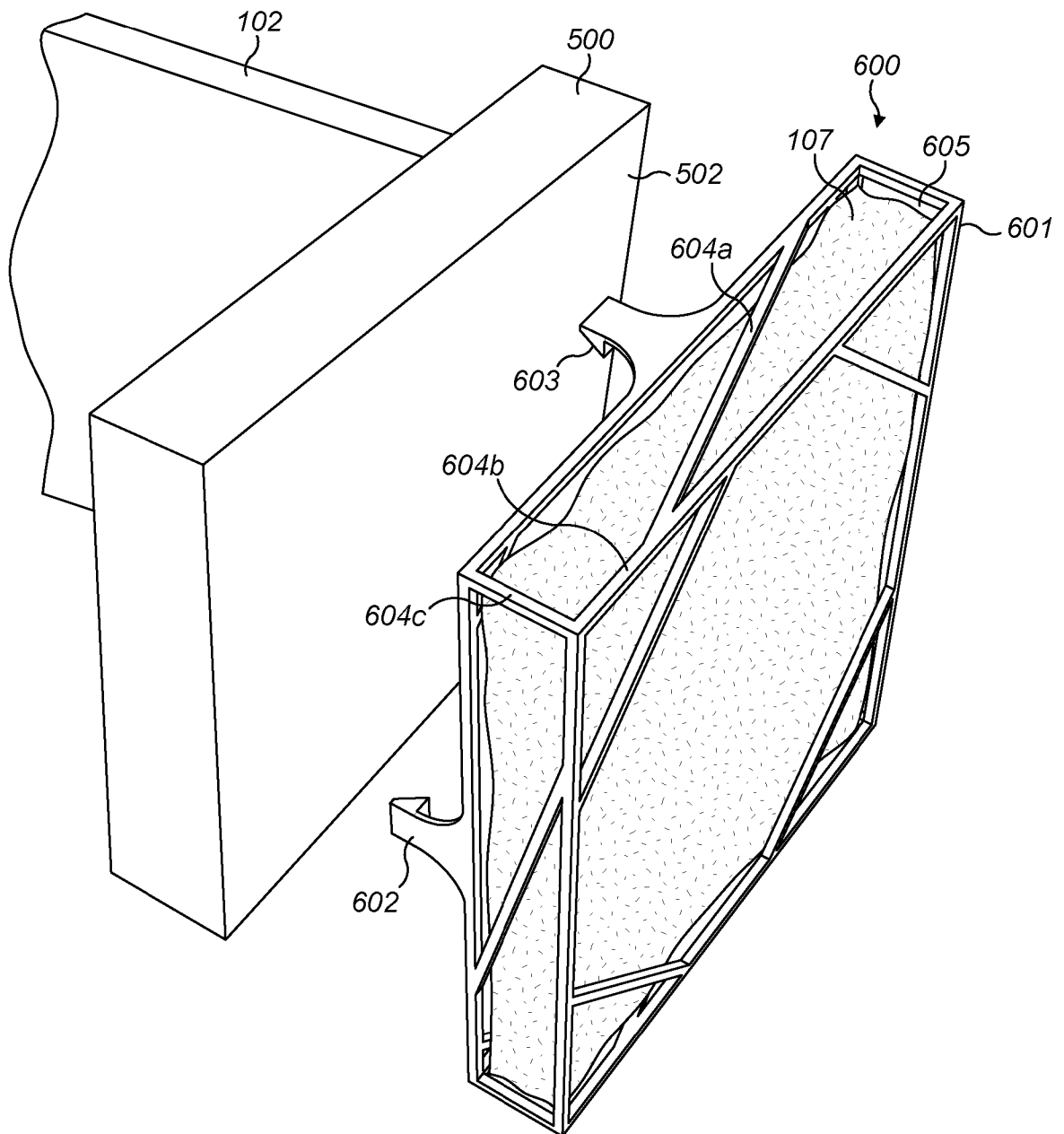

FIG. 6

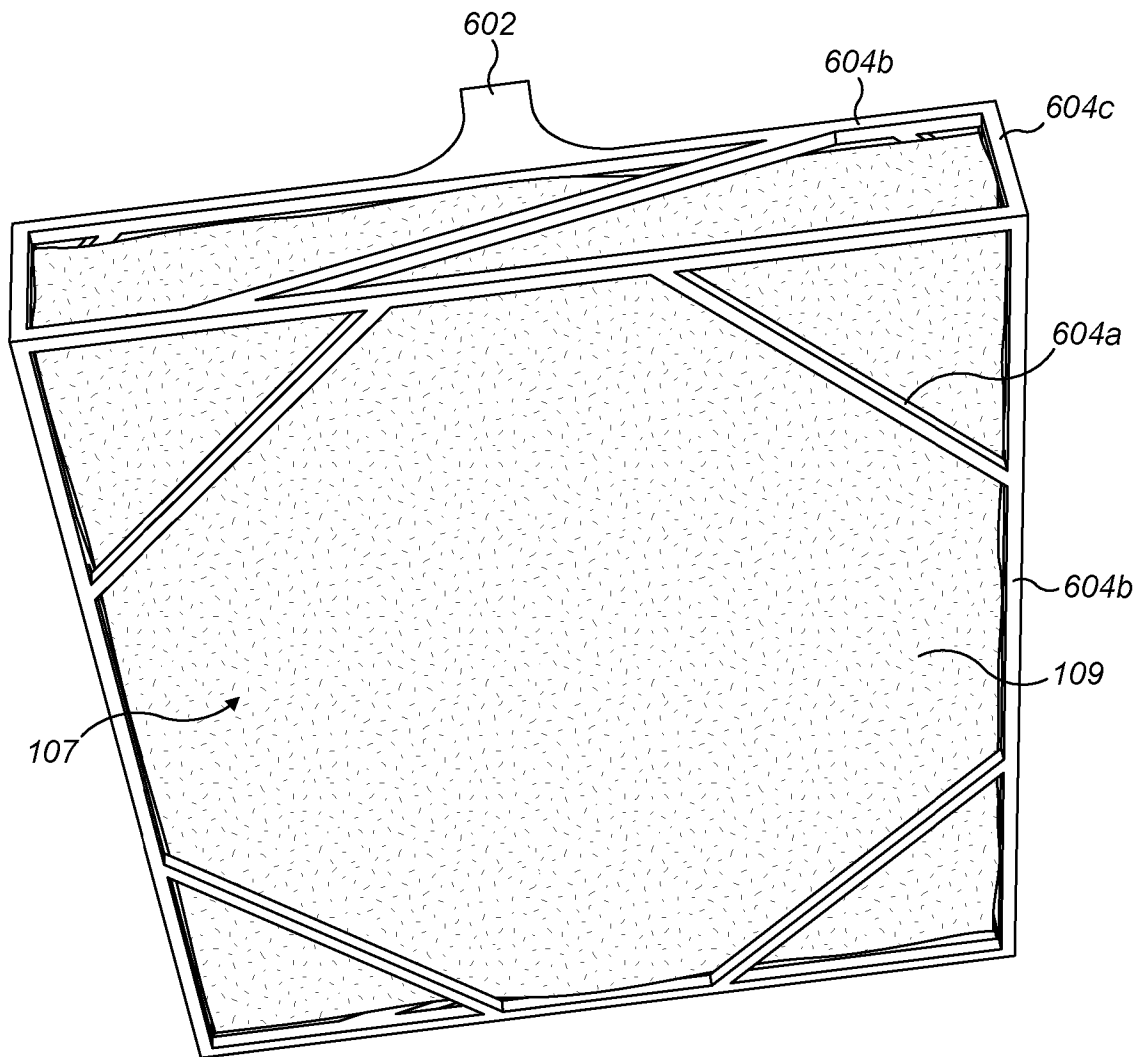

FIG. 7

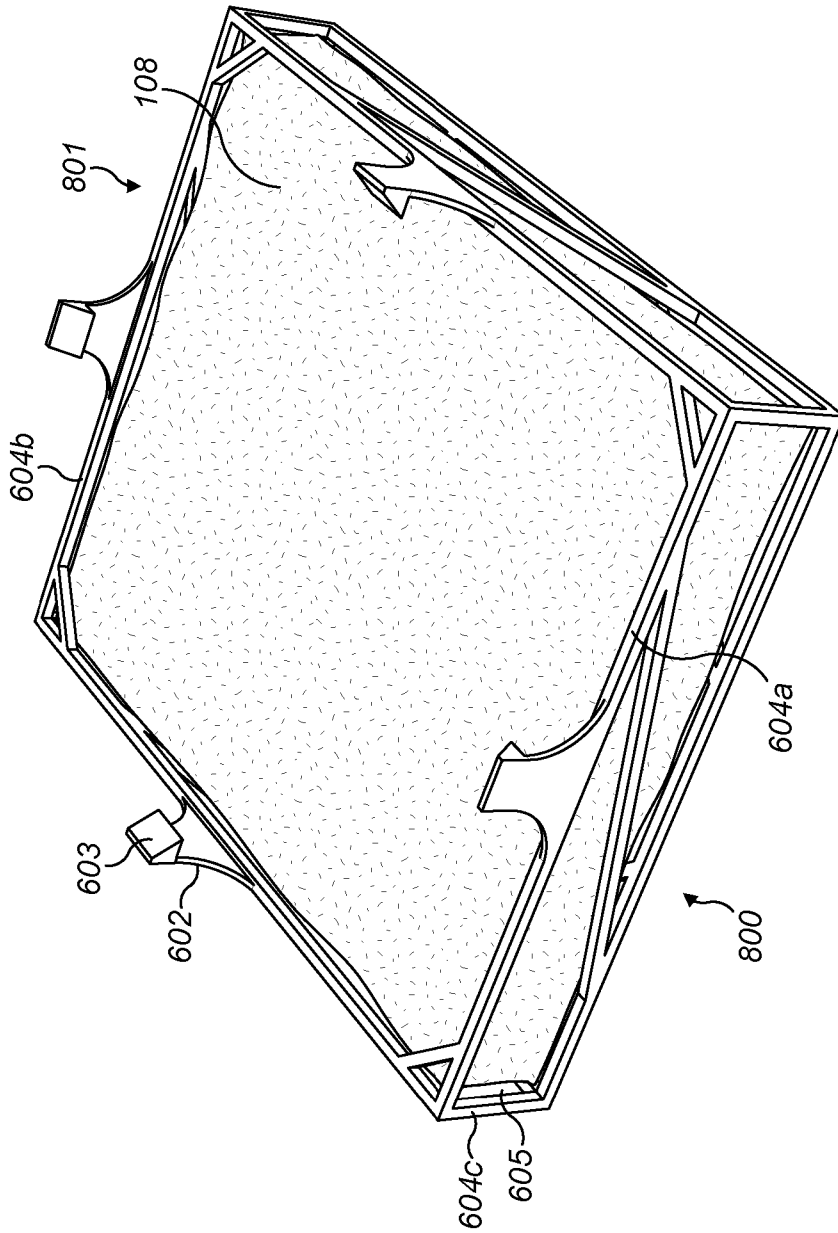

FIG. 8

INTERNATIONAL SEARCH REPORT

International application No
PCT/GB2016/051895

A. CLASSIFICATION OF SUBJECT MATTER
INV. E04F13/08 E04B1/76
ADD.
According to International Patent Classification (IPC) or to both national classification and IPC

B. FIELDS SEARCHED
Minimum documentation searched (classification system followed by classification symbols)
E04F E04B
Documentation searched other than minimum documentation to the extent that such documents are included in the fields searched

Electronic data base consulted during the international search (name of data base and, where practicable, search terms used)
EPO-Internal, WPI Data

C. DOCUMENTS CONSIDERED TO BE RELEVANT		
Category*	Citation of document, with indication, where appropriate, of the relevant passages	Relevant to claim No.
X	US 2014/026510 A1 (KUBASSEK JOHN DAVID [CA] ET AL) 30 January 2014 (2014-01-30)	1-11,15, 17-21, 30-35
Y	paragraphs [0002], [0023] - [0025]	12-14,16
A	figures 1-4b	22-29

X	US 2014/325928 A1 (WHITE DONALD GEORGE [CA] ET AL) 6 November 2014 (2014-11-06)	1-11,15, 17-21, 30-35
Y	paragraphs [0002], [0004], [0009], [0010], [0032], [0040] - [0044]	12-14,16
A	figures 1-4	22-29

	-/--	

Further documents are listed in the continuation of Box C.

See patent family annex.

* Special categories of cited documents :

"A" document defining the general state of the art which is not considered to be of particular relevance

"E" earlier application or patent but published on or after the international filing date

"L" document which may throw doubts on priority claim(s) or which is cited to establish the publication date of another citation or other special reason (as specified)

"O" document referring to an oral disclosure, use, exhibition or other means

"P" document published prior to the international filing date but later than the priority date claimed

"T" later document published after the international filing date or priority date and not in conflict with the application but cited to understand the principle or theory underlying the invention

"X" document of particular relevance; the claimed invention cannot be considered novel or cannot be considered to involve an inventive step when the document is taken alone

"Y" document of particular relevance; the claimed invention cannot be considered to involve an inventive step when the document is combined with one or more other such documents, such combination being obvious to a person skilled in the art

"&" document member of the same patent family

Date of the actual completion of the international search 16 September 2016	Date of mailing of the international search report 28/09/2016
Name and mailing address of the ISA/ European Patent Office, P.B. 5818 Patentlaan 2 NL - 2280 HV Rijswijk Tel. (+31-70) 340-2040, Fax: (+31-70) 340-3016	Authorized officer Arsac England, Sally

INTERNATIONAL SEARCH REPORT

International application No
PCT/GB2016/051895

C(Continuation). DOCUMENTS CONSIDERED TO BE RELEVANT		
Category*	Citation of document, with indication, where appropriate, of the relevant passages	Relevant to claim No.
X A	DE 10 2012 016025 A1 (NAUTH SL FASSADENTECHNIK GMBH [DE]) 15 May 2014 (2014-05-15) paragraphs [0001] - [0006], [0026], [0027], [0038] - [0041], [0059] figures 1-3,18 -----	1-5,7, 9-11, 17-21 6,8, 12-16, 22-29
X A	US 2012/137610 A1 (KNIGHT DOUGLAS JAMES [US] ET AL) 7 June 2012 (2012-06-07) paragraphs [0118], [0119] figures 20,21,25 -----	1-4, 17-21, 30-35 5-16, 22-29
X A	CA 2 820 970 A1 (KNIGHT DOUGLAS JAMES [US]) 14 September 2014 (2014-09-14) cited in the application paragraphs [0020], [0022], [0054], [0093] figures 1-3 -----	1-4, 17-21, 30-32 5-16, 22-29
L	Thermablok Aerogels: "SAFETY DATA SHEET", 27 April 2015 (2015-04-27), pages 1-6, XP055303301, Retrieved from the Internet: URL: http://www.ribaproductselector.com/Documents/6/20666/external/COL146279.pdf [retrieved on 2016-09-16] the whole document -----	5-11,15
L	Advanced Insolutions Inc: "Proloft Safety Data Sheet", 14 September 2013 (2013-09-14), pages 1-6, XP055303303, Retrieved from the Internet: URL: http://acscompositesystems.com/wp-content/uploads/2013/09/Proloft-MSDS.pdf [retrieved on 2016-09-16] the whole document -----	5-11,15
	----- -/--	

INTERNATIONAL SEARCH REPORT

International application No
PCT/GB2016/051895

C(Continuation). DOCUMENTS CONSIDERED TO BE RELEVANT		
Category*	Citation of document, with indication, where appropriate, of the relevant passages	Relevant to claim No.
Y	<p>Aspen: "Article Information Sheet Regulation (EC) No 1907/2006 and 453/2010 (REACH) Section 1 Identification of the Substance/Preparation and of the Company/Undertaking. 1.1 Product Identifier Product Type: Pyrogel XT-E 1.2 Relevant Identified Uses of the Substance or Mixture and Uses Advised Against Produ",</p> <p>³ 1 January 2015 (2015-01-01), XP055303327, Retrieved from the Internet: URL:http://www.aerogel.com/_resources/common/userfiles/file/Data_Sheets/Pyrogel_XT-E_MSDS_EU.pdf [retrieved on 2016-09-16] the whole document</p> <p>-----</p>	12-14,16
Y	<p>Aspen Aerogels: "Pyrogel Safety Data Sheet",</p> <p>⁶ 6 September 2012 (2012-09-06), pages 1-8, XP055303298, Retrieved from the Internet: URL:http://www.aerogel.com/_resources/common/userfiles/file/Data_Sheets/Pyrogel_XT_MSDS.pdf [retrieved on 2016-09-16] the whole document</p> <p>-----</p>	12-14,16

INTERNATIONAL SEARCH REPORT

Information on patent family members

International application No

PCT/GB2016/051895

Patent document cited in search report	Publication date	Patent family member(s)	Publication date
US 2014026510 A1	30-01-2014	CA 2784018 A1 US 2014026510 A1	26-01-2014 30-01-2014

US 2014325928 A1	06-11-2014	CA 2850715 A1 US 2014325928 A1	02-11-2014 06-11-2014

DE 102012016025 A1	15-05-2014	NONE	

US 2012137610 A1	07-06-2012	NONE	

CA 2820970 A1	14-09-2014	CA 2820970 A1 US 2015128518 A1	14-09-2014 14-05-2015
