

May 13, 1952

A. H. CARPENTER ET AL

2,596,324

AIR COOLER

Filed June 20, 1949

3 Sheets-Sheet 1

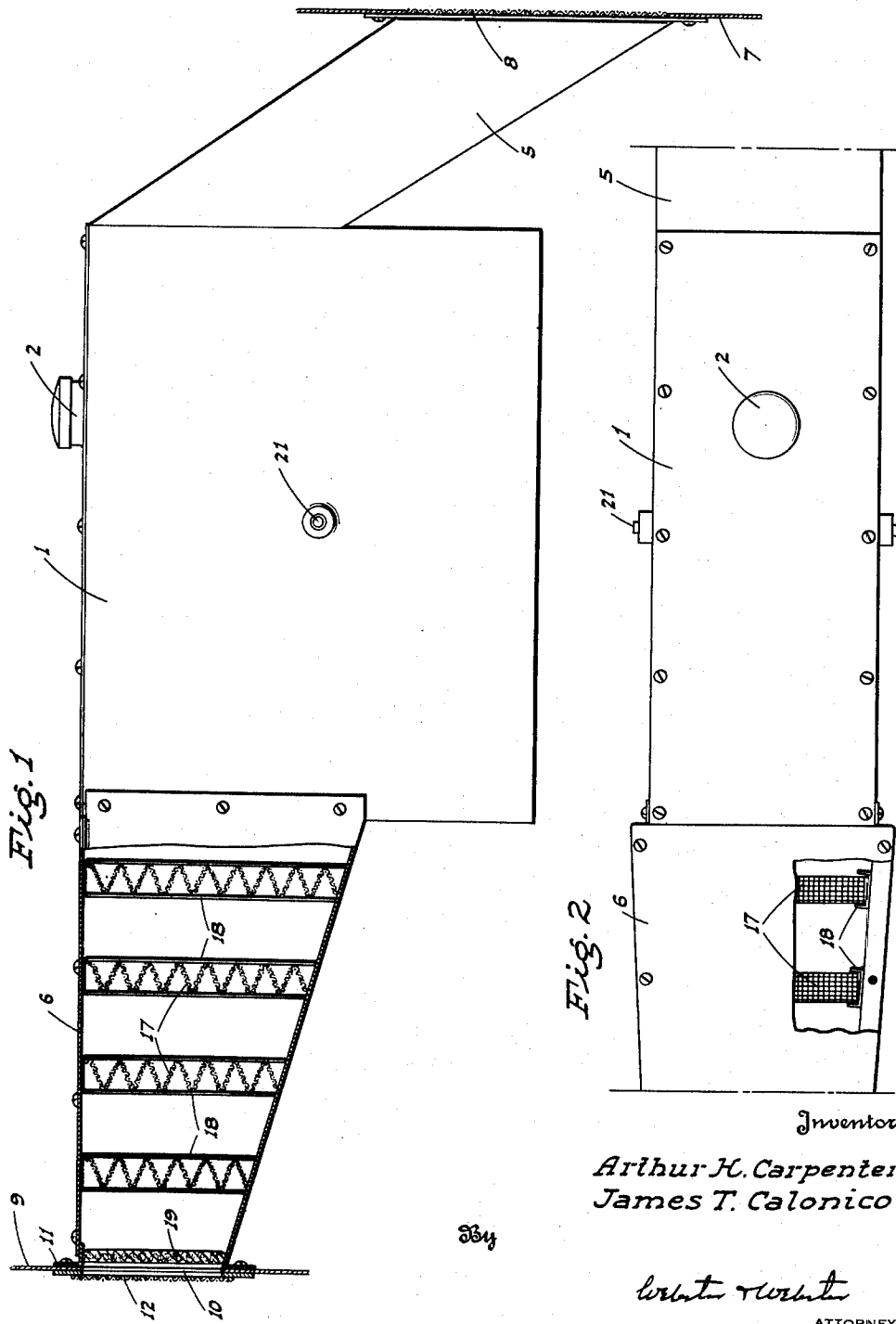

Inventors

Arthur H. Carpenter
James T. Calonic

Went Went
ATTORNEYS

May 13, 1952

A. H. CARPENTER ET AL

2,596,324

AIR COOLER

Filed June 20, 1949

3 Sheets-Sheet 2

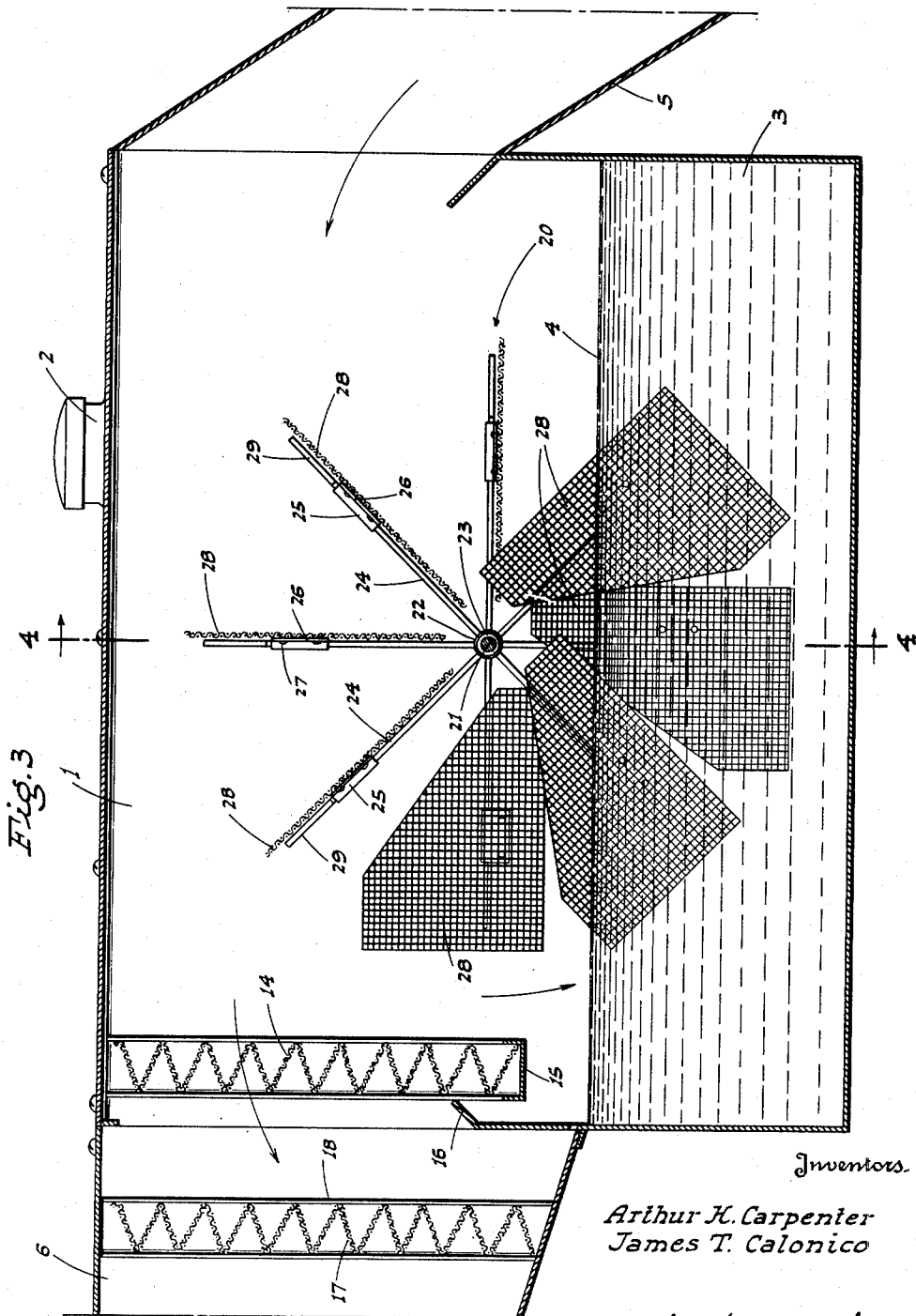

Inventors.

Arthur H. Carpenter
James T. Calonic

Leahy & Leach

ATTORNEYS

May 13, 1952

A. H. CARPENTER ET AL

2,596,324

AIR COOLER

Filed June 20, 1949

3 Sheets-Sheet 3

Fig. 4

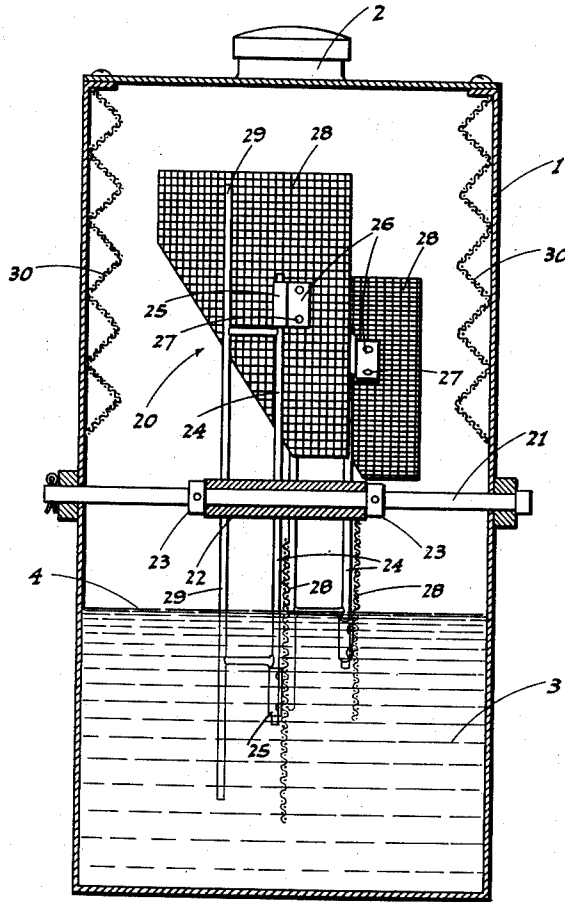

Inventors.

Arthur H. Carpenter
James T. Calonic

By

Robert Verbit

ATTORNEYS

UNITED STATES PATENT OFFICE

2,596,324

AIR COOLER

Arthur H. Carpenter, Newman, and James T. Calonico, Gustine, Calif.; said Calonico assignor to F. A. Patchett, Newman, Calif.

Application June 20, 1949, Serial No. 100,146

3 Claims. (Cl. 261—92)

1

This invention is directed to, and it is an object to provide, a novel air cooler; the device being especially designed, but not limited, for use on an automobile.

Another object of the invention is to provide an air cooler which is adapted to be interposed in, or used in lieu of, the air entry conduit of an automobile, which conduit extends from a forward intake point rearward through the bulkhead into the passenger compartment.

A further object of the invention is to provide an air cooler which includes an effective water evaporative type heat exchange assembly; the latter including a novel screen vane rotor for introducing a water spray from a tank into an air stream flowing over the water in the latter; the rotor being turnable on a transverse axis directly above the water.

An additional object of the invention is to provide an air cooler, as in the preceding paragraph, wherein the screen vanes of the rotor are turnably mounted on radial supporting rods and formed with such configuration and weight distribution relative to the rods that said vanes assume a feathered position when they approach horizontal on the down-turn, and assume a position crosswise of the direction of rotation when they approach horizontal on the up-turn; such vanes thus being feathered and offering a minimum of resistance when depending into and moving through the water in the tank, and yet being crosswise and presenting a maximum of surface to the air stream when projecting upwardly thereinto.

A separate object of the invention is to provide an air cooler wherein the heat exchange assembly includes a plurality of novel, accordion folded screens mounted across the air stream beyond the rotor in the direction of flow of the air stream; such screens being mounted in the main in an air discharge duct of the device.

It is also an object of the invention to provide an air cooler designed for ease and economy of manufacture.

A still further object of the invention is to provide a practical and reliable air cooler, and one which will be exceedingly effective for the purpose for which it is designed.

These objects are accomplished by means of such structure and relative arrangement of parts as will fully appear by a perusal of the following specification and claims.

In the drawings:

Fig. 1 is a side elevation of the air cooler with the near side plate of the air discharge duct partly broken away.

2

Fig. 2 is a top plan view of the air cooler with the top plate of the air discharge duct partly broken away.

Fig. 3 is an enlarged fragmentary sectional elevation of the air cooler showing particularly the screen vane rotor; the side screen being omitted for clarity.

Fig. 4 is a cross section on line 4—4 of Fig. 3.

Referring now more particularly to the characters of reference on the drawings, the air cooler comprises a rectangular but vertically elongated tank 1 having a capped filling neck 2 at the top thereof whereby water 3 can be delivered into such tank up to a predetermined level, which level is here indicated at 4.

An air feed duct 5 connects in communication with one end of the tank 1 above the water level 4, and an air discharge duct 6 communicates with, and leads from, the tank at its opposite end above said water level.

The air cooler is especially designed—although not limited—for interposition in, or for use in lieu of, the air entry conduit of an automobile air conditioning system, and the device in its present embodiment is for such purpose.

The air feed duct 5 leads to a forward point on the automobile and connects with a suitable mounting plate 7; there being an air filter screen 8 over the front end of said air feed duct 5.

The air discharge duct 6 leads to the bulkhead 9 and communicates with a port 10 in the latter whereby to deliver air through said port into the passenger compartment of the automobile. The duct 6 is attached to the bulkhead 9 by a securing flange 11, and the port 10 is covered by an air filter screen 12.

The air flow port between the tank 1 and the adjacent end of the air discharge duct 6 is indicated at 13, and a vertical screen 14 is disposed in front of such port 13, covering the same from side to side of the tank. The screen 14 is accordion folded, with the folds extending transversely, and such screen is supported in place by a channel shaped border frame 15. The end of the tank at the lower edge of the air flow port 13 is formed with an inturned, drip baffle 16 disposed slightly above the lower portion of the screen supporting border frame 15, as shown.

A plurality of other accordion folded screens 17 are disposed in longitudinally spaced relation transversely in the air discharge duct 6, and each of said screens 17 is supported, at opposite sides of said duct 6, by opposed inwardly facing channels 18. The screens 17 are of a configuration to engage in full matching relation in said duct 6.

The air feed duct 5 decreases slightly in cross sectional area toward the tank 1, while the air discharge duct 6 decreases sharply in cross sectional area toward its discharge end; this for the purpose of increasing the air velocity progressively as it flows through the accordion folded screens 17.

A fibrous pad 19 extends across the air discharge duct 6 across to the port 10 to assure against any water spray escaping through the air filter screen 12; said fibrous pad 19 permitting of relatively free air flow therethrough.

Within the tank 1 the air cooler is provided with a screen vane rotor, indicated generally at 20; the purpose of such screen vane rotor being to introduce water particles from the supply in the tank into the air stream which flows through such tank between the air feed duct 5 and air discharge duct 6, which stream is quite forceful when the automobile is traveling.

The screen vane rotor 20 comprises the following structural arrangement:

A cross shaft 21 is fixed in the tank 1 substantially centrally of its ends and adjacent but above the water level 2, and a sleeve 22 is freely turnable on the cross shaft 21 intermediate the sides of the tank; such sleeve being elongated and held in proper position by collars 23 on said cross shaft 21.

A plurality of equally circumferentially spaced vane mounting rods 24 are fixed on the sleeve 22 and radiate therefrom; the outer end of each rod 24 having a small bearing 25 turnable thereon.

Each bearing 25 includes a small attachment plate 26 secured as by riveting, as at 27, to the face of a screen vane 28. The screen vanes 28 are thus mounted for swinging motion, with the rods 24 as an axis, between a position extending transversely or crosswise of the direction of rotation and a feathered position with respect to such direction of rotation.

The screen vanes 28 are of such configuration and weight distribution relative to the corresponding rods that said vanes assume said feathered position as they approach horizontal on the down-turn, and assume said crosswise position when they approach horizontal on the up-turn.

The extent of swinging motion of the screen vanes 28 between such positions is approximately 90°, and said vanes are prevented from rotating beyond said crosswise position by radial stop rods 29 which are fixed to the sleeve 22 laterally of and corresponding to each rod 24.

The screen vanes 28, being feathered as they pass through the water 3 in the tank 1, then offer a minimum of resistance to rotation of the rotor 20. Further, as such screen vanes 28 are in their crosswise position when they project upwardly into the air stream through the tank 1, they present a maximum of surface to said air stream. At this time the air stream sweeps the water as a spray or mist from the screen vanes 28 toward and through the screen 14, and thence said spray or mist travels progressively through the screens 17, diminishing in amount with each thereof, on account of evaporation, which produces the desired heat exchange and air cooling.

Any moisture which passes through the final screen 17 is accumulated by the pad 19, preventing its escape through the screen 12, and of course further enhancing the air cooling effect.

It has been found that the tapering or reduction in cross sectional area of the air discharge duct 6 towards its discharge end is very beneficial

with respect to increasing the velocity of the air stream and resultant acceleration of evaporation or air cooling.

The screen vanes 28 are diagonally cut away at one corner portion for the purpose of accomplishing the desired weight distribution with respect to vane mounting rods 24, and to the end that such vanes turn between feathered and crosswise positions upon rotation of the rotor 20, as previously described. However, the perforate face area of the vanes 28 on opposite sides of the rods 24 is such that when said vanes are crosswise and projecting into the air stream, the latter urges said screens 28 rotationally toward the stop rods 29. This assures that the screen vanes 28 do not flutter, and remain in the desired crosswise position when projecting into said air stream.

The circumferentially adjacent ones of the radial rods 24 are staggered axially on the rotary sleeve 22 whereby the screen vanes 28 do not all lie in the same circumferential plane, and thus when in crosswise position only partially lap each other circumferentially of the rotor, which affords greater intersection of the air stream by said vanes than would otherwise be possible.

Within the tank opposite sides thereof are fitted, above the water level 4, with accordion folded screens 30 having the folds running lengthwise; these screens receiving a spray or mist as the rotor 20 rotates in the tank, with the result that the portion of the air stream which flows along said screens 30 produces a supplementary, evaporative heat exchange or air cooling action.

The described air cooler provides a very practical and efficient device for the cooling of air for delivery to the passenger compartment of automobiles or other enclosures.

From the foregoing description it will be readily seen that there has been produced such a device as substantially fulfills the objects of the invention as set forth herein.

While this specification sets forth in detail the present and preferred construction of the device, still in practice such deviations from such detail may be resorted to as do not form a departure from the spirit of the invention, as defined by the appended claims.

Having thus described the invention, the following is claimed as new and useful, and upon which Letters Patent are desired:

1. An air cooler comprising a tank adapted to contain liquid to a predetermined level, an air intake into the tank and an air outlet from the tank both being above the predetermined liquid level whereby an air stream may be induced through the tank above such liquid level, a shaft disposed across the tank transversely of the direction of said air flow, a sleeve mounted for free rotation on the shaft, a plurality of mounting rods fixed to the sleeve and projecting radially outward therefrom and spaced substantially equally apart circumferentially of the sleeve, a screen vane mounted on each mounting rod and adapted to be alternately carried into and out of liquid in the tank and into and out of the air stream, respectively, with the rotation of the sleeve, the mounting for the vane comprising a bearing on the vane turnably mounted on the rod about its longitudinal axis, the vane projecting laterally to each side of the rod and being of relatively large area on one side relative to the other side so as to be overweighted in a manner such that as the vane

5

moves out of the liquid in the tank and before it enters the air stream it will automatically swing to a position in which its surface will be in a plane parallel with the longitudinal axis of the sleeve, and as it leaves the air stream it will swing to a position with its surface lying in a plane at right angles to the longitudinal axis of the sleeve; each screen vane being diagonally cut away at the inner corner thereof on the lighter side of the vane.

2. A cooler as in claim 1 including a radially disposed stop bar on the sleeve laterally of each mounting rod, such stop rod projecting across and being engaged by the face of the adjacent vane when the latter lies in said plane parallel with the longitudinal axis of the sleeve.

3. A cooler as in claim 1, the vanes being disposed in alternately staggered relation relative to each other, the major part of the cut away portion of each alternate vane lapping the uncut away portion of the vane ahead.

ARTHUR H. CARPENTER.
JAMES T. CALONICO.

6

REFERENCES CITED

The following references are of record in the file of this patent:

UNITED STATES PATENTS

Number	Name	Date
55,994	Bocking -----	July 3, 1866
705,830	Evans -----	July 29, 1902
1,309,737	Ilg -----	July 15, 1919
1,827,768	Schwender -----	Oct. 20, 1931
1,846,057	Ilg -----	Feb. 23, 1932
2,022,740	Rowell -----	Dec. 3, 1935
2,031,055	McKinney -----	Feb. 18, 1936
2,060,732	Hopkins et al. -----	Nov. 10, 1936
2,062,412	Grady -----	Dec. 1, 1936
2,078,833	Bonner -----	Apr. 27, 1937
2,199,632	Keyes -----	May 7, 1940
2,427,714	Cooper -----	Sept. 23, 1947