



US 20060169401A1

(19) **United States**

(12) **Patent Application Publication**  
**Magnitskii et al.**

(10) **Pub. No.: US 2006/0169401 A1**

(43) **Pub. Date: Aug. 3, 2006**

(54) **METHOD OF MAKING FLUORESCENT DISCS**

**Related U.S. Application Data**

(75) Inventors: **Sergey Magnitskii**, Moscow (RU);  
**Dimitrij Pebalk**, Moscow (RU);  
**Vladimir Shubin**, Moscow (RU);  
**Eugene Levich**, New York, NY (US);  
**Andrey Tarasishin**, Moscow (RU);  
**Alexej Lezhnev**, Moscow (RU);  
**Vladimir Kozenknov**, Dolgoprodnyj (RU);  
**Mihail Kvasha**, Moscow (RU);  
**Gailna Dorozhkina**, Dolgoprodnyj (RU);  
**Nikolay Magnitskii**, Moscow (RU)

(62) Division of application No. 09/616,965, filed on Jul. 14, 2000.

(60) Provisional application No. 60/144,019, filed on Jul. 15, 1999.

**Publication Classification**

(51) **Int. Cl.**  
**B32B 37/00** (2006.01)  
**B32B 38/04** (2006.01)  
**B29C 65/00** (2006.01)  
(52) **U.S. Cl.** ..... **156/272.2**

Correspondence Address:  
**WINSTON & STRAWN LLP**  
**1700 K STREET, N.W.**  
**WASHINGTON, DC 20006 (US)**

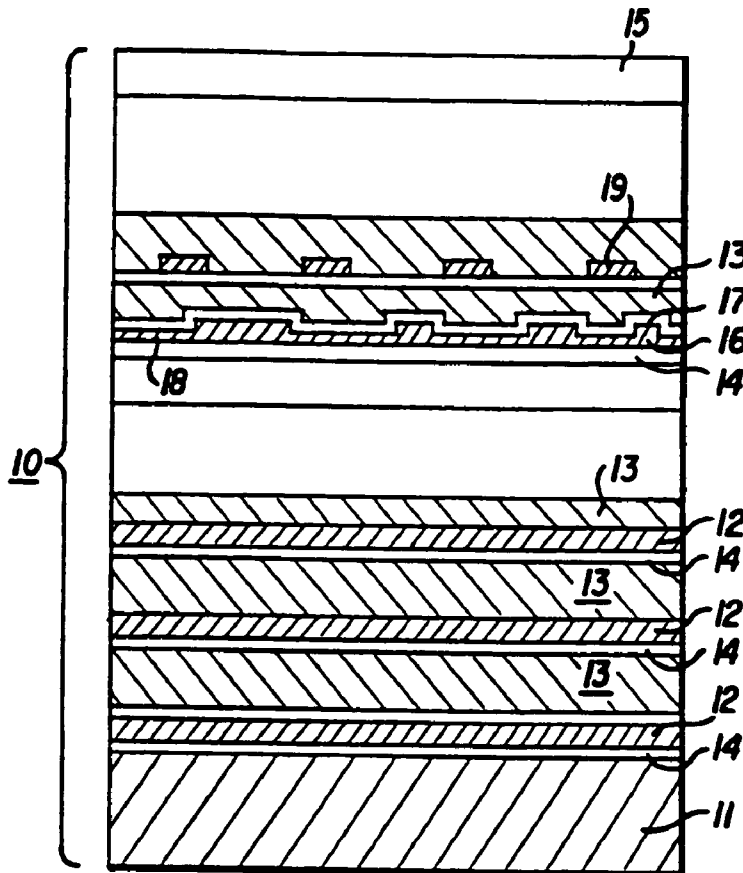
(57) **ABSTRACT**

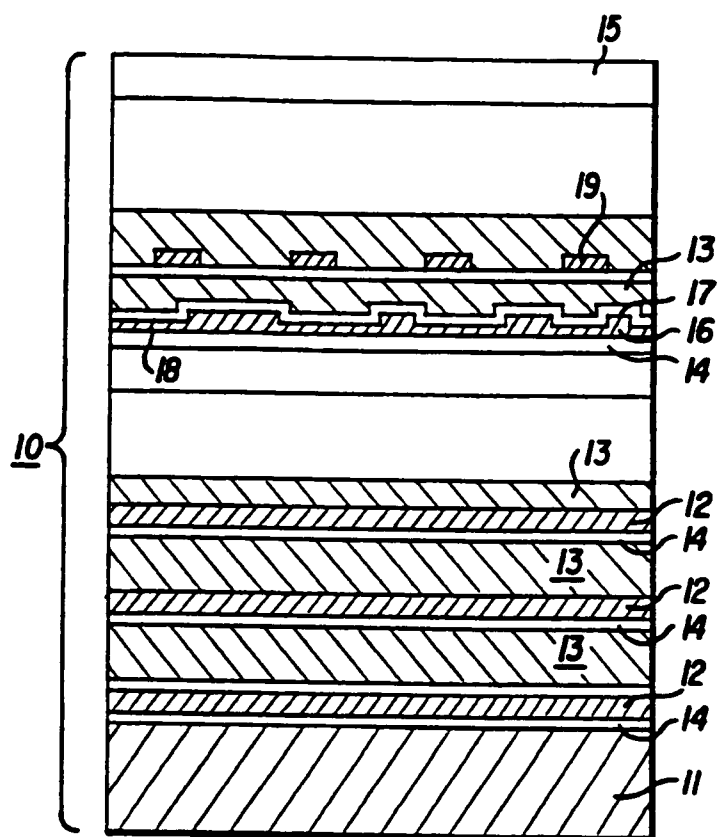
A method of obtaining a hybrid fluorescent optical disc, that includes subsequent layer-by-layer forming of information-carrying layers with microrelief like pits or spiral grooves, filling of ROM, WORM or RW microrelief with fluorescent material and assembling them together to form a multilayer structure.

(73) Assignee: **D Data Inc.**

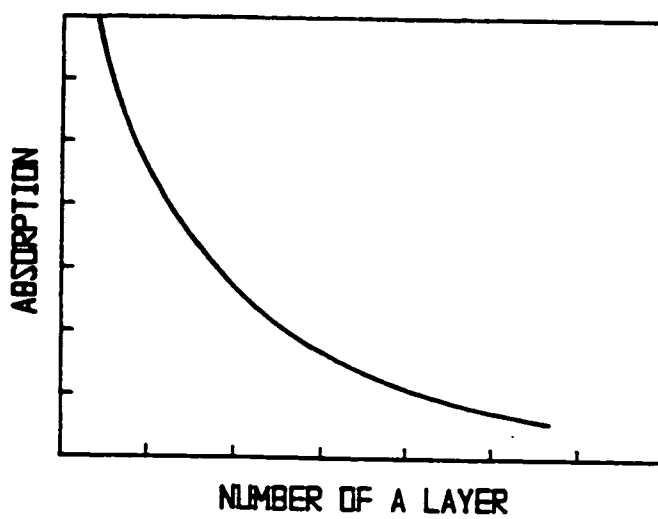
(21) Appl. No.: **11/371,813**

(22) Filed: **Mar. 8, 2006**

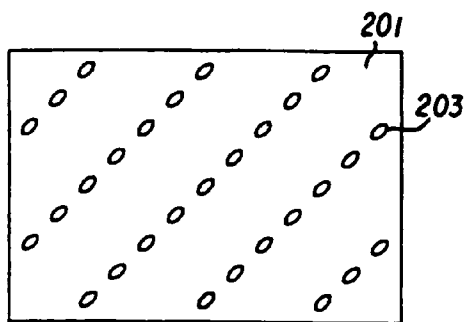




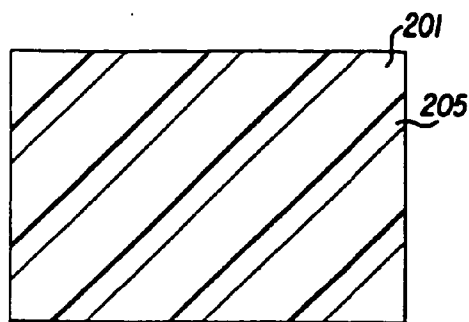
**FIG. 1**



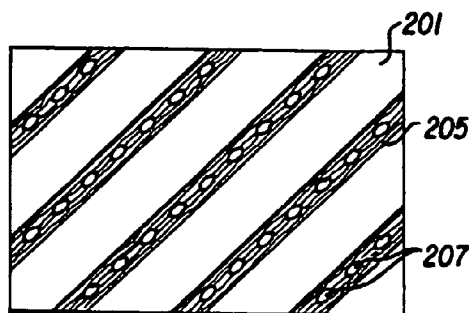
**FIG. 3**



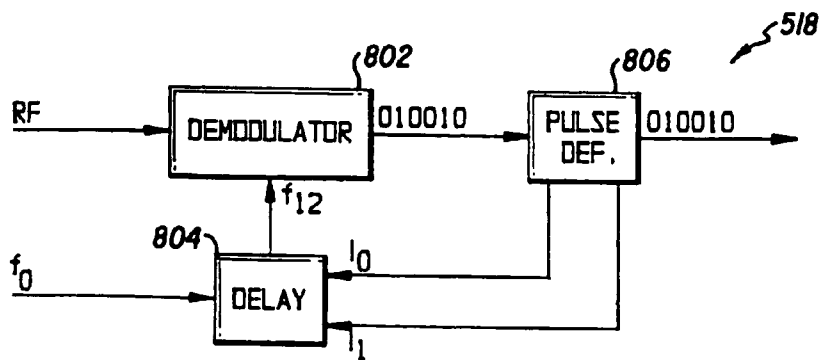
**FIG. 2A**



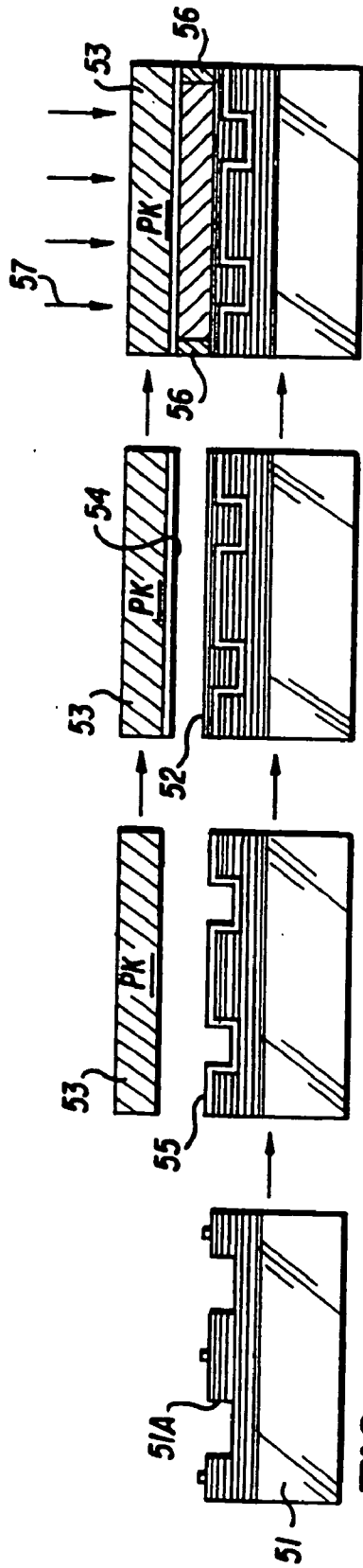
**FIG. 2B**



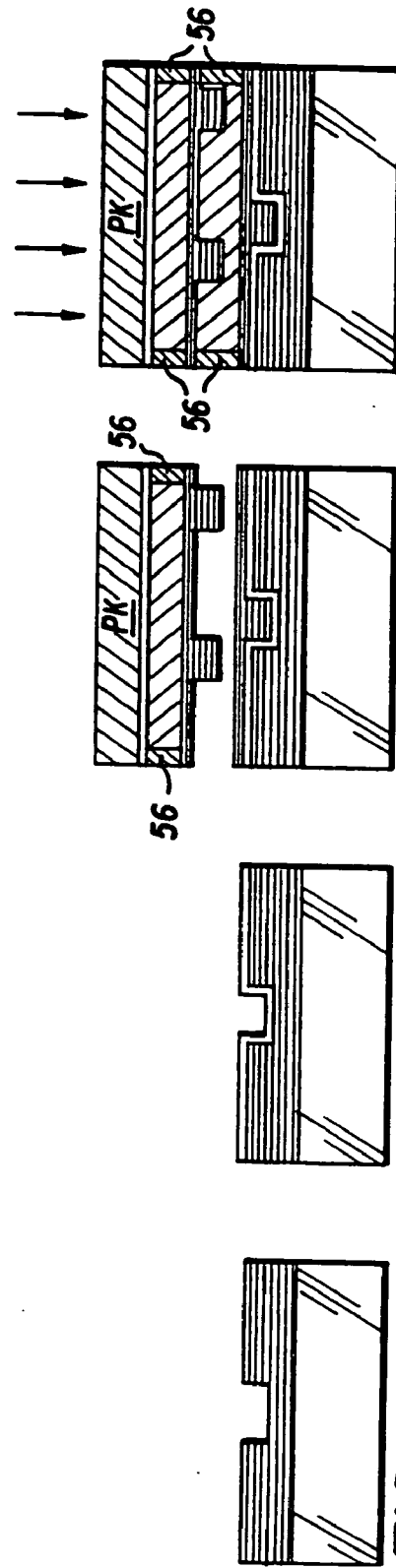
**FIG. 2C**



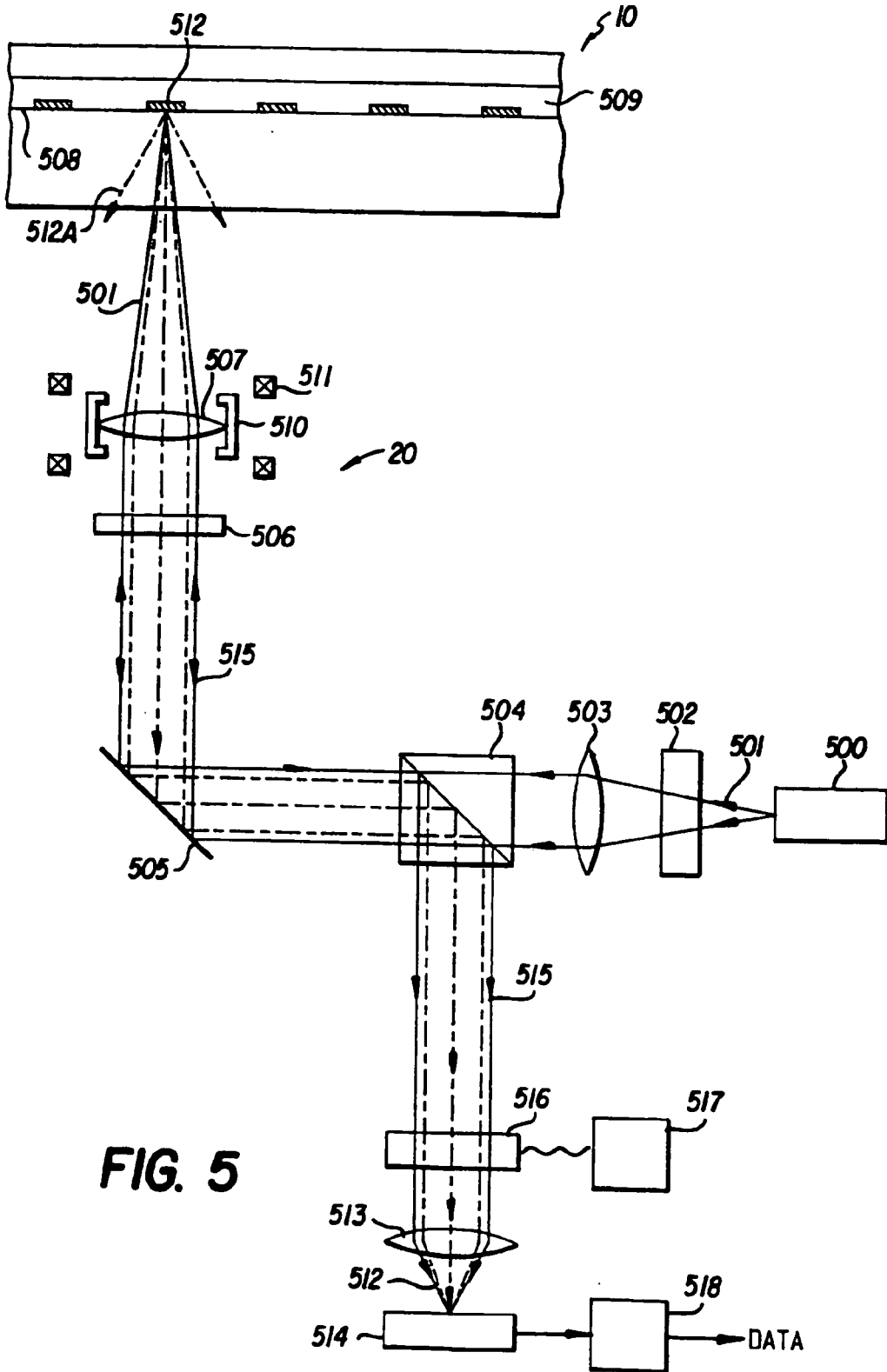
**FIG. 8**



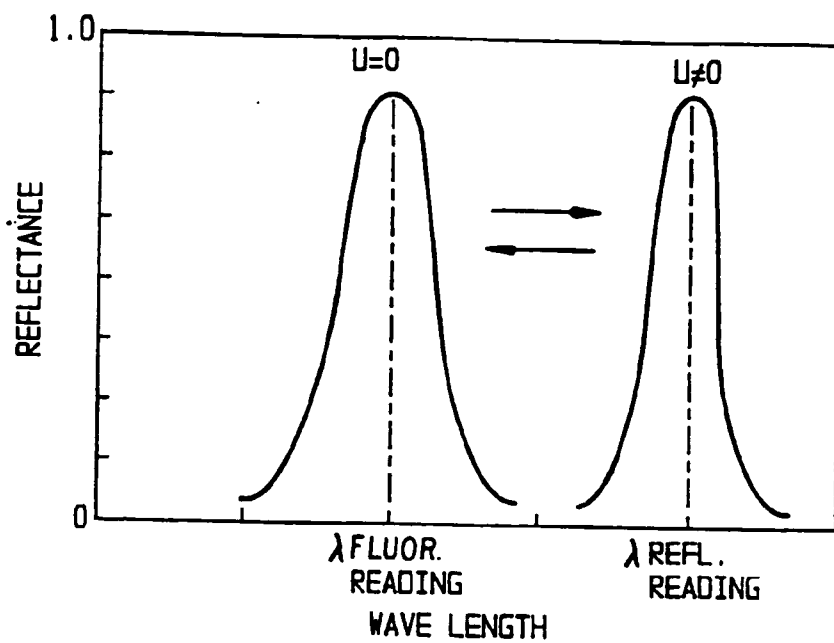
**FIG. 4A**



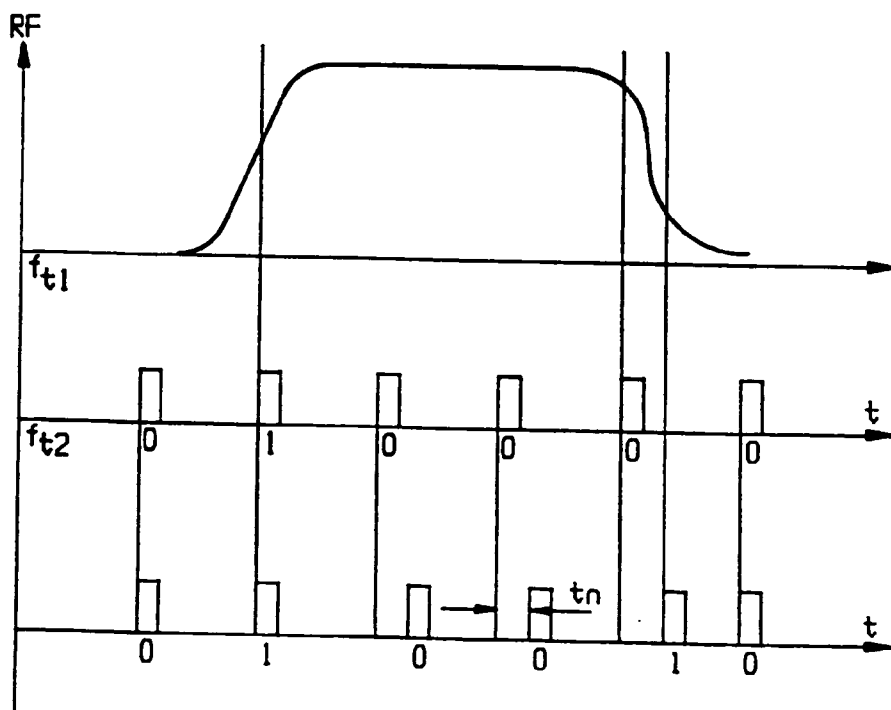
**FIG. 4B**



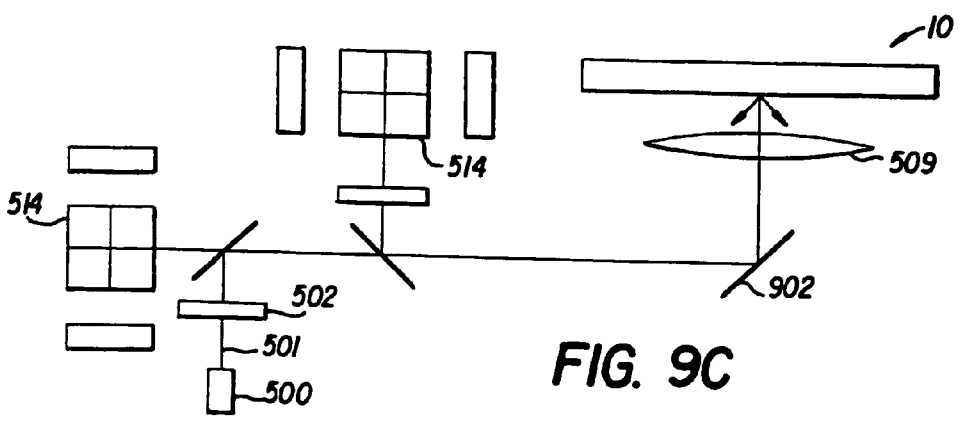
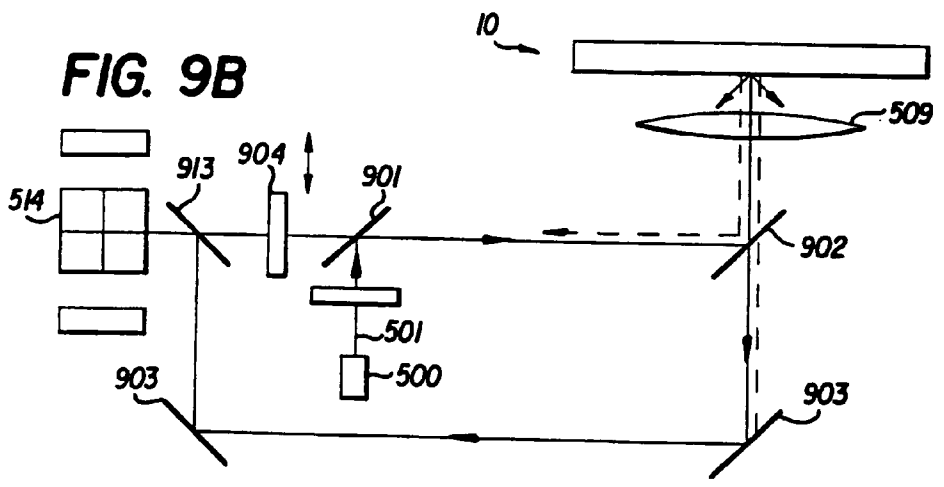
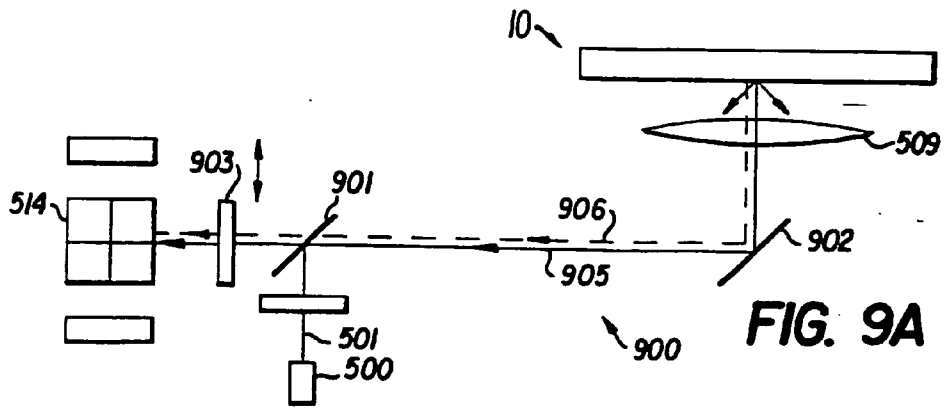
**FIG. 5**

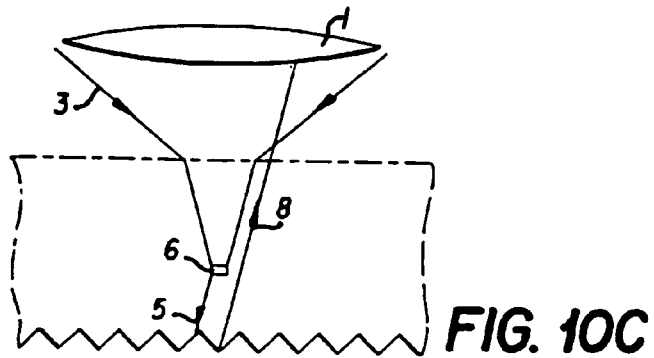
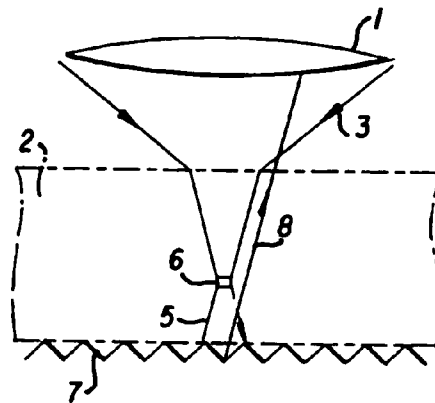
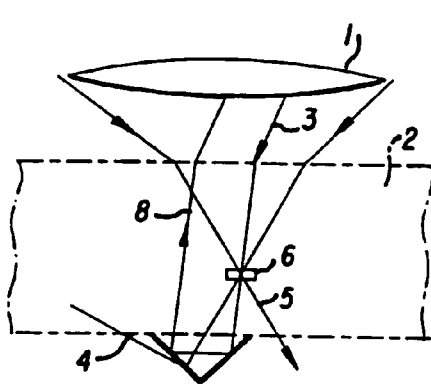
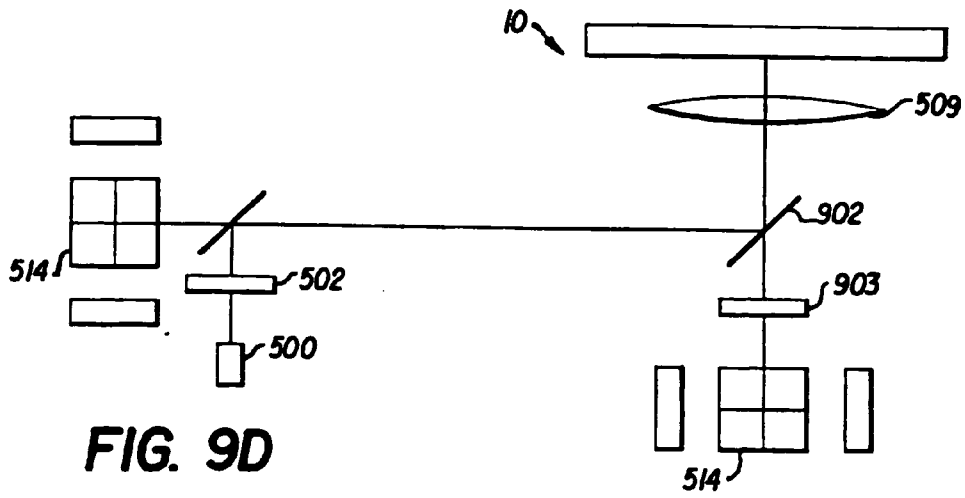


**FIG. 6**



**FIG. 7**







**METHOD OF MAKING FLUORESCENT DISCS**

REFERENCE TO RELATED APPLICATIONS

[0001] The present application is a divisional of U.S. application Ser. No. 09/616,965, filed Jul. 14, 2000, which claims the benefit of U.S. Provisional Application No. 60/144,019, filed Jul. 15, 1999, the disclosure of each of which is expressly incorporated herein by reference.

BACKGROUND OF THE INVENTION

[0002] 1. Field of the Invention

[0003] This invention relates to an optical storage system and more specifically to a storage system comprising a fluorescent disc with many information layers and a drive for reading information from such a disc.

[0004] 2. State of the Art

[0005] Single-layer (as well as two-layer) two-dimensional optical storage systems are widely used in existing devices. Most of the previous technical solutions in such systems of optical data storage were based on registering the change of reflected laser radiation intensity in the local spots (pits) of the data carrying layer. These changes could arise from light interference on the relief optical discs like CD ROM, from reversible polarization effects in magneto-optical or photoanisotropic media, as well as from reversible or non-reversible changes of reflection index in phase change media, or from dyes clearing up in “dye-reflection layer” systems, etc.

[0006] Three-dimensional (i.e., multilayer) optical memory devices provide higher capacity of recorded or stored data than two-dimensional systems. However, they have certain restrictions and additional requirements for construction and different features for recording media, and ways of recording and reading data, especially in the depth of the registering media.

[0007] In the reflection regime, every data-carrying layer of a multilayer optical medium requires a partly reflective covering. The use of such coverings reduces the intensity of both the reading beam and the reflected, data carrying beam as a result of direct and reverse passage through the medium towards the necessary data-carrying layer and back to the receiver. In addition, both coherent beams are subject to difficult-to-estimate diffraction and interferential distortions on the spots (pits and grooves) of the data-carrying layers while being transmitted.

SUMMARY

[0008] The present invention relates to a method of obtaining a hybrid fluorescent optical disc. The method includes subsequent layer-by-layer forming of information-carrying layers with microrelief like pits or spiral grooves, filling of ROM, WORM or RW microrelief with fluorescent material and assembling them together to form a multilayer structure.

[0009] In particular, the invention relates to a method of making a multilayer hybrid fluorescent optical disc with fixed luminescence pits or grooves, which comprises: preparing a relief surface having optically detectable marks in an optically transparent layer; filling the optically detectable marks with a liquid polymerizable composition; polymerizing the liquid polymerizable composition to form a poly-

merized layer capable of carrying information; and assembling at least two polymerized layers into a single unit to form a multilayer disc.

BRIEF DESCRIPTION OF THE DRAWINGS

[0010] Preferred embodiments of the present invention will be set forth in detail with reference to the drawings, which show the following:

[0011] **FIG. 1.** Disc cross section showing a structure of a multiple layer fluorescent optical disc as a first embodiment of the present invention.

[0012] **FIGS. 2A-2C.** Configuration of pits in ROM and information signals, recorded in fluorescent WORM grooves.

[0013] **FIG. 3.** Distribution of absorption coefficients in layers of a 10-layer fluorescent disc and of reflection coefficients in a 10-layer reflective disc.

[0014] **FIG. 4A.** Steps of forming a recording layer of a fluorescent optical disc.

[0015] **FIG. 4B.** Steps of forming subsequent recording layers of a fluorescent optical disc.

[0016] **FIG. 5.** A simplified flowchart of an optical data storage system as the first embodiment of the present invention.

[0017] **FIG. 6.** A plot reflectance for the Notch filter as a spectral filter.

[0018] **FIG. 7.** Voltage epurs.

[0019] **FIG. 8.** The flowchart of a compensation system according to the present invention.

[0020] **FIGS. 9A-9D.** Schematic flowchart of an optical data storage system according to the present invention.

[0021] **FIGS. 10A-10C.** Schematic examples of multilayer fluorescent optical disc structure with angled mirrors.

DETAILED DESCRIPTION OF THE PREFERRED EMBODIMENTS

[0022] Preferred embodiments of the present invention will now be set forth in detail with reference to the drawings.

[0023] Let us compare theoretical and real fluorescent multilayer discs (FMD) with reflective multilayer discs (RMD) from the point of information signal values. It is assumed that both discs have spiral tracks with pits according to the DVD standard. A focusing objective with a fixed numerical aperture focuses the information signal (output signal from the disc).

[0024] Ideal RMD—a multilayer reflective disc with each layer being an ideal reflector with fixed reflection ratio. All effects but reflection, such as absorption, dispersion, etc., are neglected. The whole reflected signal carries information.

[0025] Ideal FMLD—a multilayer fluorescent disc with a constant refraction index in the volume. There is no absorption outside the pits, while the pits are filled with fluorescent dye with a fixed absorption index and its fluorescence quantum yield is equal to 1. The overlapping of the reading beam with the pit is equal to 1.

Fluorescence is emitted isotropically in all directions without absorption inside the disc. Reception efficiency is defined by full material reflection of the disc, that is equal to  $NA=1$ . Fluorescence photon energy is equal to reading laser photon one.

[0026] The sufficient information signal value from layer  $i$  of a multilayer disc depends upon reflection coefficients (for RMD) and absorption coefficients in pits (for FMLD) distribution in the layers. Thus, coefficient distribution requires optimization. For fixed coefficient distribution between layers, information signal values from layers will also have a certain amplitude distribution. Let's mark minimum of  $n$  signals ( $n$  is the number of disc layers) as  $P_{min} = \min P_i$ . Optimization means such coefficient distribution over layers, when  $P_{min}$  reaches its maximum.

[0027] It can be proved that equality of all information signals is the necessary requirement for optimization:  $P_i = P_{opt} = \text{const}$ .

RMD-system

[0028] Let's assume layer  $i$  has reflection index  $R_i$ . Then, the ideal reflection disc transmittance  $T_i = 1 - R_i$ . Notice that the beam passes the above layers (with respect to reading one) twice. The equation for the reflection coefficient  $R$ , is:

$$R_i = R_{(i+1)}(1 - R_i)^2, \text{ where } R_n = 1,$$

from which we get  $R_i$  value in a recurrence relation

$$R_i = \frac{1 + 2R_{i+1} - \sqrt{1 + 4R_{i+1}}}{2R_{i+1}}, \quad i = n - 1, n - 2, \dots, 1 \quad (1)$$

with  $P_{opt} = P_o R_1$ , where  $P_o$  is the incident radiation power on the disc surface.

[0029] See Table 1 for the exact dependence of a signal in ideal RMD on the number of layers, calculated according to formula (1):

TABLE 1

	Signal value in ideal RMD system.					
	Number of layers					
	5	10	20	30	50	100
$P_{opt}/P_o, 10^{-2}$	12.3	5.6	2.7	1.8	1.0	0.51

[0030] In real CD/DVD technology, the reflective coverage is obtained by metal film deposition. It is known that in the visible spectrum range, i.e., in the studied wavelength range around 600 nm, metal films have both high reflection and high absorption coefficients. This is true at least for such widely used materials as Al, Ag, Au at  $\lambda \sim 600$  nm [see the reference book *Physical values* by I. S. Grigoryev, E. Z. Meylikhova, Energoatomizdat, 1991 for parameters]:

	Material		
	Al	Ag	Au
R	0.9	0.95	0.7
$A = 1 - R$	0.1	0.05	0.3

[0031] Thus, in a real RMD system, every layer will possess both fixed reflection coefficients and finite absorption. To provide high transmittance in a multilayer RMD system, we should deposit very thin films, as the skin-layer in metals at  $\lambda \sim 600$  nm is about 500 Å. However, with a decrease in the film thickness the absorption coefficient increases within a maximum range of 100 Å, where the absorption coefficient is equal to ten percent for most metals. Thus, to provide high transmission in RMD system, we should use films up to several tens of angstroms thick, but even in this case the absorption coefficient remains too high. For example, gold film with about a 50 Å thickness has a reflection coefficient of 0.172 and a transmission of 0.542, thus its absorption coefficient is 0.286 at  $\lambda = 650$  nm [For the structure of evaporated metal films and their optical properties, see JOSA, vol. 40, p. 203-211, 1950]. According to evaluations of an ideal system, in multilayer reflection disc optimization, the layers' reflection coefficient is equal to 1-5%. Silver film fulfills these requirements. A thin silver film up to 100 Å thick has a reflection coefficient nearly equal to its absorption coefficient. Therefore, there arises monotonic dependence between reflection and absorption coefficients. We use the following equation to calculate reflection coefficient  $R_i$ :

$$R_i = R_{(i+1)}(1 - 2R_i)^2, \text{ where } R_n = 1.$$

[0032] Then we get  $R$ , value as a recurrence formula:

$$R_i = \frac{1 + 4R_{i+1} - \sqrt{1 + 8R_{i+1}}}{8R_{i+1}}, \quad i = n - 1, n - 2, \dots, 1 \quad (2)$$

with  $P_{opt} = P_o R_1$  where  $P_o$ —incident radiation power on the disc.

[0033] See Table 2 for the exact dependence of a signal in such RMD on the number of layers, calculated according to the equation (2):

TABLE 2

	Signal in RMD with thin silver film.					
	Number of layers					
	5	10	20	30	50	100
$P_{opt}/P_o, 10^{-2}$	6.74	2.94	1.36	0.89	0.52	0.26

FMLD System

[0034] Let's assume an absorption coefficient in a pit of layer  $i$  in an ideal FMLD equal to  $a_i$ . Fluorescent signal

power  $P_i^{fl}$  from the pit in layer  $i$ , falling on the lens aperture, can be described as:

$$P_i^{fl} = P_o \varphi_{fl} k \xi a_i \prod_{j=1}^{i-1} (1 - A_j),$$

where  $\varphi_{fl}$  is the fluorescence quantum yield,  $k$  is the coefficient of light-beam overlapping the pit;

$$\xi = \frac{1 - \sqrt{1 - (NA/n_r)^2}}{2}$$

is the lens collection coefficient,

where  $NA$  is the numerical aperture,  $n_r$  is the polymer refraction index, and  $A_i$  is the total absorption in the  $i$ -layer.

[0035] For a fluorescent disc,  $A_i = (S_{pit}/S_o) a_i$ , where  $S_{pit}/S_o$  is the ratio of the square filled by pits to the total disc surface square.

[0036] The information signal power is given by:

$$P_{opt} = \gamma P_o R_1 = \gamma P_o \frac{1}{S_o/S_{pit} + (n - 1)}, \quad (3)$$

$$\gamma = \varphi_{fl} k \xi (S_o/S_{pit})$$

[0037] For an ideal disc of the DVD standard,

$$\varphi_{fl} = 1; k = 1; (S_o/S_{pit}) = 4; \xi = \frac{1 - \sqrt{1 - (1/n_r)^2}}{2}$$

[0038] As it was fixed before, the collection coefficient in an ideal disc is defined by the total internal reflection angle, which depends on the reflection index of disc  $n_r$ . Hence, the use of emersion optics allows collection efficiency increases of up to 100%. Therefore, let's assume the collection coefficient in an ideal FMLD system is equal to 100%.

[0039] See Table 3 for the exact dependence of a signal in an ideal FMLD system on the number of layers, calculated according to equation (2):

TABLE 3

Signal value in ideal FMLD system.						
	Number of layers					
	5	10	20	30	50	100
$P_{opt}/P_o, 10^{-2}$	50	31	17.4	12.1	7.6	3.9

[0040] In a real FMLD, the main factors decreasing the information signal power are limited by the collection coefficient, decreased fluorescence quantum yield, and restricted overlapping of the laser beam with the pit. Reflection

from layers can be neglected, as reflection coefficients of different layers can be chosen equally with an accuracy of up to 10%, which brings Fresnel reflection on every edge below 0.1%.

[0041] First, let's consider the DVD-like optical scheme with  $NA=0.65$  and a polycarbonate disc. Dye fluorescence quantum yield in a polymer matrix can exceed 0.95, so we consider it to be equal to 1. Then at a collection coefficient of 4.4% and a beam overlap with pit 0.8, we receive the following signal values in the multilayer system:

TABLE 4

	Signal value in FMLD system with DVD-like optical scheme.					
	Number of layers					
	5	10	20	30	50	100
$P_{opt}/P_o, 10^{-2}$	1.7	1.1	0.61	0.43	0.27	0.14

[0042] At the same time, as stated above, maximum collection in FMLD system depends on the total internal reflection angle. From the other side, according to our investigations, the minimum polymer refraction index is equal to 1.4. Thus, increasing the lens numerical aperture up to 1 (the limit for non-emersion objective), allows us to increase the collection coefficient up to 0.15. Under these conditions, the coefficient of beam overlapping with a pit is close to 1, providing the following signal values in the multilayer system:

TABLE 5

	Maximum signal value in an FMLD system with non-emersional objective.					
	Number of layers					
	5	10	20	30	50	100
$P_{opt}/P_o, 10^{-2}$	7.5	4.7	2.6	1.8	1.13	0.582

[0043] Thus, the analysis of both systems shows advantages of a fluorescent system in signal values in comparison to a reflective system. Potentially, the signal value in the FMLD system is four times higher than in the ideal reflective system.

[0044] FIG. 1 shows schematically a fluorescent optical disc according to a preferred embodiment. The fluorescent optical disc 10 includes a transparent protective substrate 11 and successive data-carrying layers 12, located one above another, separated by polymer layers 13, and assembled in a single block by gluing the layers 14. A lacquer coverage 15 protects the fluorescent disc 10 from mechanical damage and aggressive media. A substrate 11 is a flat glass, polycarbonate, polymethylmethacrylate, or other polymer plane, transparent to visible light. The substrate 11 can be 0.6 mm or 1.2 mm thick with the diameter of 120 mm. The protective layer 15 is obtained by deposition and drying of a resin solution or by polymer film lamination with adhesive. Intermediate layers are 10-300  $\mu m$  thick.

[0045] The protective layer 15, intermediate layer 13, adhesive layer 14, and information layer 12 have refractive

indices at reading and fluorescence wavelengths close to one of the substrate **11**. It is necessary to remove light reflection on the layer boundaries. There are several means by which the layers may be separated, such as:

[0046] A polymer solution may be poured onto the optical disc, followed by solvent evaporation.

[0047] An isotropic polymer film may be laminated with an adhesive on the optical disk.

[0048] The use of a UV-cured liquid or "dry film" photopolymerizing composition is the most interesting variant for obtaining separating layers. See **FIGS. 4A and 4B**, which illustrate the technological process of obtaining thin separating layers, which will be described below in greater detail.

[0049] Every data-carrying surface **12** is located on the separating layer **13** surface within FMLD bulk **10**.

[0050] In general, an FMLD can contain only ROM layers or can also contain WORM and RW layers.

[0051] Another alternative is the possibility of also including in an FMLD spatially-separated reflective ROM, WORM or RW layers of a non-fluorescent nature (magneto-optical or phase change). The refraction index of these data layers differs from the separating layer refraction index.

[0052] It is preferable to place the transparent fluorescent layers closer to the reading radiation source, with reflective layers behind them.

[0053] As one can see from **FIG. 1**, spatially-separating information layers can be fully fluorescent (layer **16**), if the fluorescent substance fills not only pits (ROM) or grooves (WORM) **17**, but also the space **18** above them. In this case, absorption and fluorescence in pits or grooves will have higher absolute intensity.

[0054] In another variant, data layers have island-like structures, where only pits and grooves **19** are filled with fluorescent substance, providing higher contrast at reading.

[0055] See **FIGS. 2A-2C** for CCD-microimages of a substrate **201** having fluorescent pits **203** (ROM, **FIG. 2A**), grooves **205** (WORM, **FIG. 2B**) and recorded images **207** in the grooves **205** (WORM, **FIG. 2C**).

[0056] We propose to widen the pit in comparison to the CD/DVD standard. In a CD or DVD, pit width is limited not by cross-talk from adjacent tracks, but by the fact that with interferential subtraction of radiation reflected from a pit from radiation of all spots, at a certain pit width the complete suppression of a reflected signal becomes possible. Increasing the width further, we get the reflected signal increase and the information signal decrease. For fluorescent discs, pit width is limited by cross-talk from adjacent tracks. The model calculations show 30% signal increase at a pit width 0.6  $\mu\text{m}$ , while signal/noise ratio remained tolerable and equal to 70. From the above reasoning, we propose increasing the pit width up to 0.6  $\mu\text{m}$ .

[0057] As stated above, the information signal value from FMLD layer *i* sufficiently depends on the absorption coefficients' distribution in pits and grooves of the different FMLD layers. Thus, the coefficients' distribution requires optimization. At the given distribution of absorption coef-

ficients between the layers, fluorescent information signals from pits will have the same distribution of intensity.

[0058] It is a necessary optimization requirement that all information signals have equal intensity, irrespective of their location within the disc.

[0059] See **FIG. 3** for the absorption coefficients' distribution in layers, calculated for an ideal fluorescent disc.

[0060] See **FIG. 4A** for a schematic description of the technological steps of forming the FMLD data-carrying layers, as one of the examples of the present invention.

[0061] The proposed method is based on successive, layer-by-layer forming of data-carrying layers with microrelief of pits or grooves, filling ROM, WORM or RW microrelief with fluorescent material, and their assembly as a multilayer structure.

[0062] Various methods used for mass replication of relief optical elements, such as CD-ROMs, relief holograms, and diffraction gratings, etc., can be used to form layers with microreliefs.

[0063] Use of liquid photopolymerized compositions (PhPC) or dry photopolymerized films, applied in microelectronics, is most preferable as a relief-base material.

[0064] According to the present process, the layer PhPC **52** is deposited on a glass or metal disc stamper **51** with cavities (pits or grooves) **51A** and covered with a polycarbonate, glass or another substrate **53**. To improve adhesion, the substrate can be covered with an adhesive layer **54**. Anti-adhesive **55** (typically 100  $\text{\AA}$  thick) is used to diminish PhPC adhesion to stamper **51**. Layers **54, 55** are optional.

[0065] Use of liquid PhPC allows utilization of spacers **56** with calibrated thickness (say, 10-30 microns). In case of dry film, PhPC spacers are not needed.

[0066] After PhPC is deposited and covered with substrate **53**, the obtained sandwich is exposed to UV-radiation **57** until it is fully hardened.

[0067] The sandwich is dismantled and the obtained replica is covered with a fluorescent composition.

[0068] Then the operations are repeated N times to obtain an N-layer disc, as shown in **FIG. 4B**.

[0069] In this case PhPC combines the functions of relief base, separating, and gluing substances.

[0070] An important problem during FMLD production is optimization of filling technology for the pits and grooves in the every data-carrying layer. Such optimization increases the contrast (the ratio of signals from fluorescence centers in pits to background signal from the layer surface outside pits). For the prototype of this decision, see the proposal described in "Fluorescent Optical Memory," U.S. Nonprovisional application Ser. No. 08/944,402, filed on Oct. 6, 1997, based on U.S. Provisional Application No. 60/032,521, assigned to OMD Ltd. Here, a better method of volume filling the data-carrying layer surface cavities with fluorescent composition is proposed, which results in a higher fluorescent intensity difference between the useful signal from fluorescence centers in surface cavities and the background signal from the layer surface outside cavities.

[0071] The following method is proposed for production of multilayer fluorescent discs with fixed fluorescence centers (pits or grooves):

[0072] A. Relief surface preparation

[0073] The surface of an optically transparent data-carrying layer is physically or chemically treated in order to:

[0074] A1. Change its surface energetic properties;

[0075] A2. Change its hydrophilic/hydrophobic properties, and improve its surface wetting by deposition of a liquid polymerized composition;

[0076] A3. Improve the adhesion of the polymerization product to the surface; and

[0077] A4. Diminish the surface electric charge density or change the charge polarity, which influences surface sorption and aggregation of luminophors with polar or ionic (cation or anion) functional groups.

[0078] Possible methods of changing the surface physical and chemical characteristics and its chemical nature include: alkaline or acid hydrolysis; chemical or photochemical oxidation in active gas agents (i.e., oxygen) of functional surface groups, which if needed, could be modified chemically; halogenization; and sulfating or amination of surface macromolecules. The surface can be also processed by surface-active substances, deposition of antistatic substances on the surface (i.e., by aerosol spraying), adhesion promoters, covering with films of other chemical nature, through plasma-chemical processing, and also through processing in crown charge.

[0079] B. The optically transparent layer, prepared as described in A, with pits (cavities of certain form) on the surface, is covered with liquid polymerizing composition, containing:

[0080] B1. One or more liquid low-volatile components (monomers, oligomers) polymerizing under heat or electromagnetic- radiation (light or radiation-chemical effect);

[0081] B2. A solvent, if necessary, consisting of one or more components, which is more volatile than the liquid polymerizing components and does not dissolve the substrate material. The solvent can contain components with reactive functional groups, capable of being polymerized together with the polymerizing components described in

[0082] B3. A polymerization catalyst, if necessary;

[0083] B4. A luminophore, consisting of one or more components, capable of being dissolved in the solvent and the polymerizing components. The luminophore can contain components with reactive functional groups, capable of being polymerized together with the polymerizing components as described in B1;

[0084] B5. Other additives, to improve the homogenous luminophore distribution in the liquid polymerizing components, and adhesion promoters as well.

[0085] In the case of low-viscous polymerizing components, use of the solvent described in B2 is not

required, as one of the polymerizing components from B1 can dissolve other components.

[0086] C. The surface cavities of the information layer are filled in such a manner that allows a maximum difference between composition volume in the cavities (see B) and on the surface outside them. For example,

[0087] C1. The liquid composition described in B is deposited on a substrate (disc) surface. Then the disc is rotated at a certain rate for a certain time. As a result, the highly volatile components of the solvent are removed from the composition with gradual accumulation of liquid low-volatile polymerizing components with dissolved luminophore in the surface cavities. Centrifugal force and solvent evaporation serve to withdraw excess liquid components from the substrate surface.

[0088] This sequence of operations can be repeated the necessary number of times to provide maximum filling of cavities. Mixing of the deposited composition with the liquid polymerizing components, and filling the pits in the process of deposition is hindered by their strong difference in viscosity.

[0089] C2. There is another method of filling the continuous cavities or channels (i.e., spiral). In this case, we apply an auxiliary plane transparent substrate to the substrate surface with cavities, fixing it mechanically or by pasting the edges together and providing for their maximum contact (i.e., by vacuum). Therefore, we get a substrate with an empty continuous channel and with a fixed volume. Then the channel is filled through a hole on the edge of the pasted substrates or a hole from the plane substrate, with the composition described in B, whose viscosity is decreased by adding the solvent with reactive polymerizing groups. As a result of the capillary effect, the channel is filled with polymerizing composition. Pressure overfall between the channel ends can improve the process of filling. Then, if necessary, the two substrates can be disassembled.

[0090] D. After all operations described in C are completed, the liquid components should be polymerized by photochemical or thermal impact. This process is done to avoid luminophore destruction or change of the luminescence spectrum during polymerization hardening. For thermal polymerization one should apply certain temperatures and use appropriate initiators. If photochemical polymerization is used, one should choose certain photoinitiators and irradiation with the appropriate spectrum. For example, light filters can be used to selectively impact only the photoinitiator. The above-described method provides for formation of luminescence centers, fixed in cavities on the substrate surface.

[0091] E. To increase the difference in the luminescent intensity of the polymerized composition in cavities and the remaining polymer film on the substrate surface outside the cavities, it is necessary to reduce the luminophore concentration or its luminescence in the surface layer. For example, plasmochemical surface etching can reduce the surface film layer. Radical polymerization (i.e., for acrylates) can be realized through photoradiation of the liquid polymerizing composition from the substrate side, so that air or oxygen serves as an inhibitor, e.g., prevents surface layer polymer-

ization. Thus they remain liquid and can be withdrawn from the substrate surface (i.e., by surface processing in a suitable solvent). The other possible method is a selective dosage over time on the surface exposed to UV-radiation, which causes a change of the chemical nature of the luminophore (i.e., photodestruction) in the sub-surface layer. Another possible method is an impact of dosed exposure to radiation of a certain spectrum (i.e., UV-light), on the additional substance in the composition, which forms a fluorescence quencher under light. A fluorescence quencher can also be brought into the sub-surface layer by dosed diffusion from its liquid (solution) or gas (vapor) phases during their contact with the information layer surface.

[0092] The present invention also offers the following method of multilayer optical disc manufacture with fixed luminescence centers. The initial composition, containing solvent, polymerization components, cure catalyst, and auxiliary substances described in B1, B2, B3, B5, does not contain the luminophore described in B4. The cavities on the substrate surface are filled with liquid polymerizing substance, as described above. Thermal- or photocuring is used for polymerizing components. Photocuring in this case does not require a light filter to speed up the process. The surface is then etched (i.e., plasma-chemically), to withdraw the remaining polymerized film outside the cavities. The surface thus has different physical and chemical properties in the region of cavities and outside them, including density, porosity, wetting and absorption ability, etc. Then the obtained substrate is brought into contact with a liquid (solution) or gas (vapor) phase, containing a luminophore. The luminophore diffuses into the polymerized composite in the surface cavities with selective absorption of luminophores. Then the process of thermal or photo processing follows, for drying and fixing the luminophore.

[0093] After performing the above operations, the obtained information layers are glued to each other by one of the methods shown in FIGS. 4A and 4B, using materials with certain optical characteristics (i.e., optically transparent in the spectrum range above 300 nm with a refraction index equal to that of the substrate). Thus, we obtain a multilayer disc with fixed luminescence centers.

[0094] The information layers are either glued by autoclave pressing, using connecting polymer films (i.e., polyvinylbutyrate, siliconorganic, urethane) located between them, or by pouring monomers or oligomers between the layers with their further polymerization. The polymerizing components used can be the same as those used in the luminophore composition (B).

[0095] See FIG. 5 for the simplified scheme of an optical data storage system using the fluorescent optical disc 10.

[0096] This optical system is constructed as a ROM or WORM and RW type optical disc retrieving apparatus, in which the circularly polarized beam falls on the fluorescent optical disc 10 and the recorded information is detected as the fluorescence radiation intensity varies.

[0097] Optical head 20 includes a laser diode 500 producing a primary linearly polarized light beam 501 at approximately 650 or 780 nm. Grating 502 diffracts beam 501 to produce two secondary beams for tracing, in addition to the first primary beam.

[0098] The resulting three-component beam is transmitted through the lens 503 and beam splitter 504 and is reflected

by mirror 505 and then passes the quarter-wavelength plate 506. The plate 506 makes the beam circularly polarized. Then the light beam passes through a focus of the lens 507 and is focused onto one of the data surfaces (surface 508 of substrate 509) of fluorescent optical disc 10. Lens 507 is mounted to holder 510, which is adjusted to an optical disc position by the focus actuator motor 511.

[0099] In case there is an informative pit 512 in this microregion, the laser beam 501 is partly absorbed and reemitted as fluorescent radiation 512A. This radiation is focused on a multi-sector detector 514 with the help of the lens 507, mirror 505, and beam splitter 504. Part of the laser beam 501 can be reflected from the data surfaces 508 and utilized as a reflection beam 515.

[0100] When the reflected beam 515 passes through the  $\lambda/4$  plate 506, it becomes linearly polarized, while its polarization plane turns 90 degrees. Thus, the reflected beam 515 is split by the beam splitter 504 and directed on the detector 514.

[0101] The above system can diminish the signal-noise ratio at fluorescent reading. However, in contrast to the reading laser radiation, fluorescent radiation is not polarized and has another wavelength. Therefore, they can be separated by spectrum or polarization filters 516, such as passive, i.e., interferential or dichroic filters, polarizers of Glan-Tompson type or film-laminated polaroids. It is possible to use the built-in electrically controlled spectrum filters of Notch type on the base of holesteric liquid crystals or of Pockels cells' type. See FIG. 6 for the reflection spectrum of such a filter at two values of controlling voltage from unit 517. One can see that such filters provide quality filtration upon the spectrum. Thus, such device provides data retrieving both from fluorescent ROM, WORM or RW optical discs and the usual CD or DVD ROM, WORM and RW systems of magneto-optical and phase-change types.

[0102] One of the problems in reading from fluorescent multilayer discs is to compensate the influence of fluorescent dye lifetime on data pulse duration. It is also possible to increase maximum reading rate.

[0103] It is known that the pulse front is defined at the moment of clock pulses switching (FIG. 7). Because of jitter, this moment can coincide not with the edge, but with the pulse peak or bottom. Then a wrong decision is possible. We propose the following method of compensation. After the leading edge is registered, the device 518, shown in FIG. 5 and described schematically below with reference to FIG. 8, provides a time shift of all clock pulses on time, approximately equal to fluorescence lifetime. In this case, the clock pulse will coincide with the trailing edge, thus compensating the delay influence. After the trailing edge is registered, a time shift of the clock pulses is cancelled. At a fluorescence lifetime of 2-3 ns, a disc rotation rate of 10 is possible. The proposed method can compensate the front delaying up to 0.2-0.3 ns, thus, making it possible to reach the rate of up to  $\times 100$  without limitations.

[0104] See FIG. 8 for the flowchart of the compensating device 518, additionally placed on the multi-segment optical detector output (FIG. 5). It includes a demodulator, which receives an RF signal and a signal at  $f_{12}$ , which demodulates the signal at the coming of signal at  $f_{12}$ . The last is formed in a controlled delay circuit 804 which delays pulses at  $f_{11}$  on

the time  $\tau_n$  after it receives signal  $1_1$  (that is  $f_{t2}=f_{t1}+1/\tau_n$ ) on its controlling input. After it receives pulse  $1_0$ , the delay circuit becomes disconnected and the unit just emits pulses at  $f_{t2}=f_{t1}$ . The pulse edge sign definition scheme **806** generates pulse  $1_1$  when passing the RF signal leading edge or pulse  $1_0$  when passing its trailing edge.

[0105] See FIGS. 9A-9D for another schematic flowchart of an optical storage system with a mechanically pushed-in interference filter **903**, as described in the present invention. In this scheme, radiation **501** from semiconductor laser **500** ( $\lambda=650$  or  $780$  nm) via semi-transparent mirror **901**, mirror **902**, and aspherical lens **509**, is focused on the information layer of the optical disc **10**. The reflected **905** or fluorescent signal **906** (depending on the disc type) sent via semi-transparent mirror **901** is received by a multi-segment photodetector **514**. Depending on the type of the disc **10**, the interference filter **903** which transmits radiation with fluorescence wavelength  $\lambda_n$ , and does not transmit with the laser wavelength, is pushed in front of the multi-segment photodetector. The disc type can also be recognized automatically. For this purpose, in a starting position the filter should be in front of the photodetector and, if after the start of reading there is a signal on the output of the photodetector, it is an FMLD disk; if there is no signal, then it is either a CD or DVD disc. In the latter case a filter is pushed forward and the photodetector receives the signal on the laser wavelength reflected from the disk.

[0106] See FIG. 9B for the FMLD drive scheme with dichroic mirrors **902**. In contrast to the above-described drive, here the reflected **905** or fluorescent **906** signal from the optical disc is received by a dichroic mirror **902**, which reflects radiation at a laser wavelength and transmits the radiation at a fluorescence wavelength  $\lambda_n$ . Then the fluorescent signal passes through a system of dichroic mirrors, which also serve as spectrum filters, and is received by a multisegment photodetector **514**. Depending on the disc type, the shutter **904**, which stops the reflected radiation at laser wavelength, is either pushed back or forward. The disc type can also be recognized automatically following the above procedure.

[0107] See FIG. 9C for FMLD drive scheme, which is aligned in the same plane as the two photodetectors. Unlike the two previous schemes, it has no moving elements, but has an additional photodetector. Similar to the above described scheme, the reflected or fluorescent signal from the optical disc is received by dichroic mirror **902**, which reflects radiation at the fluorescence wavelength  $\lambda_n$ , and transmits radiation at the laser wavelength. Then the fluorescent signal at  $\lambda_n$  passes through the filter to the first multi-segment photodetector, and radiation at the laser wavelength is received by the second multi-segment photodetector. In this case, the disc type can be recognized automatically by the signal presence on the appropriate photodetector output.

[0108] The difference between the schemes in FIGS. 9C and 9D is that the latter requires one mirror less, hence the reading device is located both in parallel and in perpendicular planes to that of the disc.

[0109] Thus, the devices shown in FIGS. 5 and 9A-9D can provide reading and recording both on FMLD, CD and DVD, thus broadening their application range.

[0110] To increase the received fluorescent signal, we propose placing a light-collecting element on the back side of the disc, for example, an angle reflector as a mirror or pyramid (see FIG. 10A-C).

[0111] In this case, the fluorescent radiation **5** passes through the back side of the optical disc **2**, is reflected by the angle reflector **4**, and then is collected **8** by the aspherical lens **1** of the drive's reading system. This method allows nearly double the fluorescent signal.

[0112] The angle reflector can be realized as a separate element **4** (FIG. 10A), which follows the position of the reading spot **3,6** with the help of a special device and combines optical axes of the reading system with those of the angle reflector. The second way to realize this method is to form micro-angle reflectors **7** on the disc surface (see FIG. 10B). At reading, this disc is located under the FMLD.

[0113] The third variant of the method's realization is to form micro-angle reflectors **9** on the FMLD back side (see FIG. 10C). In this case, it is possible to avoid radiation losses caused by reflection on the disc-air and air-disc boundaries, which can take place in the previous two variants. The micro-angle reflectors can be formed in a similar way to pit forming technology on CD, with following metal deposition for increasing reflectivity.

[0114] To obtain a maximum signal on the photodetector located in the focal plane of the drive's aspheric lens, acting also as a spatial selector, the geometric sizes of angle reflector  $d$  should be much less than the spot radiation from which is collected by the lens:

$$d < \lambda \sqrt{(1/(1-(NA/n)^2))},$$

where  $h$  is the distance between the pit and the angle reflector; NA is the lens numerical aperture; and  $n$  is the disc refraction index.

[0115] While various preferred embodiments of the present invention have been set forth above, those skilled in the art who have reviewed the present disclosure will readily appreciate that other embodiments can be realized within the scope of the present invention. For example, the thicknesses and numbers of layers are illustrative rather than limiting. Therefore, the present invention should be construed as limited only by the appended claims.

What is claimed is:

1. A method of making a multilayer hybrid fluorescent optical disc with fixed luminescence pits or grooves, comprising:

preparing a relief surface having optically detectable marks in an optically transparent layer;

filling the optically detectable marks with a liquid polymerizable composition;

polymerizing the liquid polymerizable composition to form a polymerized layer capable of carrying information; and

assembling at least two polymerized layers into a single unit to form a multilayer disc.

2. The method of claim 1, wherein the relief surface is prepared by hydrolysis, oxidation, halogenization, sulfating, amination, processing by surface-active substances, deposition of antistatic substances, application of adhesion pro-

moters, covering with a film of another chemical nature, plasma-chemical processing, or processing in crown charge.

3. The method of claim 1, which further comprises rotating the layer to remove volatile components of the composition and to concentrate fluorescent material in the composition in the optically detectable marks.

4. The method of claim 3, which further comprises depositing the composition in a central location of the layer as the layer is rotated.

5. The method of claim 1, which further comprises applying a transparent auxiliary plane to the layer to provide an assembled substrate with the optically detectable marks being filled through a hole in the assembled substrate.

6. The method of claim 5, wherein the auxiliary plane is applied by fixing the plane mechanically to layer or by adhering the edges of the plane and layer together.

7. The method of claim 5, further comprising separating the assembled substrate to obtain the filled marks.

8. The method of claim 1, wherein the liquid polymerizable composition is polymerized photochemically or thermally.

9. The method of claim 1, wherein the liquid polymerizable composition comprises a luminophore.

10. The method of claim 9, which further comprises reducing the concentration of the luminophore on the sur-

face outside the optically detectable marks, and wherein the layer is provided with a complete coating of the liquid polymerizable composition on its surface.

11. The method of claim 10, wherein the concentration of the luminophore is reduced by etching, exposure to radiation, or contacting a fluorescence quencher.

12. The method of claim 1, wherein the polymerized layers are assembled by gluing the layers together by autoclave pressing, connecting adhesive polymer films between the layers, or by applying and polymerizing monomers or oligomers between the layers.

13. The method of claim 1, further comprising etching the surface after polymerizing the composition to remove the polymerized composition from the surface outside the optically detectable marks.

14. The method of claim 13, wherein the liquid polymerizable composition does not contain a luminophore and which further comprises contacting the etched substrate with a luminophore, and subsequently polymerizing the luminophore onto the polymerized composition in the filled marks.

\* \* \* \* \*