

19



51

Inter. Cl. 8

B01B 43/00 (06.01)

11

N° 16637

FASCICULE DE BREVET D'INVENTION

21

 Numéro de dépôt : 1201300439
(PCT/IB12/051910)

22

Date de dépôt : 17/04/2012

30

 Priorité(s) :
ZA n° 2011/02937 du 19/04/2011

24

Délivré le : 30/09/2014

45

Publié le : 01.12.2015

73

Titulaire(s) :

 FOURIE, Stefan Adrian,
RE 757, Featherbrooke Estate,
1739 KRUGERSDORP (ZA)

72

Inventeur(s) :

FOURIE, Stefan Adrian (ZA)

74

 Mandataire : Cabinet Spoor & Fisher Inc. Ngwafor
& Partners, Blvd. du 20 Mai, Immeuble Centre
Commercial de l'Hôtel Hilton, 2è Etage, Porte
208A, B.P. 8211, YAOUNDE (CM).

54

Titre : Water treatment system.

57

Abrégé :

The invention concerns a reactor 30, 50 for use in a clarifier 10 of a water treatment system. The reactor 30 includes a body 32 for receiving a stream of wastewater from a feed line 16 of the clarifier. The body 32 has a first opening 38.1 which is, in use, an upper opening through which clarified water is released and second opening 38.2 which is, in use, a lower opening through which slurry is dispensed. The wastewater stream introduced into the body 32 is accelerated by using acceleration means 34, in particular a venturi located below the outlet 18 of the feed line 16. A diverting formation 36 is further positioned in line with the accelerated stream of wastewater so that the wastewater stream strikes the diverting formation after having been accelerated. The invention also concerns a clarifier 10 including a reactor 30, 50 as well as a method of clarifying wastewater in a reactor 30, 50 of the clarifier 10. (fig. 3)

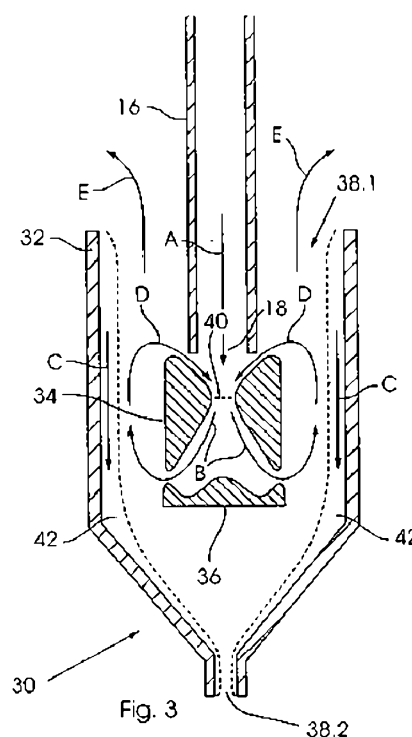

"WATER TREATMENT SYSTEM"**BACKGROUND TO THE INVENTION**

5

This invention relates to a water treatment system. In particular, but not exclusively, this invention relates to a reactor for use in a water clarifier or settler in a water treatment system for clarifying wastewater in the mining industry and a method of clarifying the wastewater.

10 Clarifiers, or settlers as they are also referred to, are well known in the field of water treatment and generally form part of a water treatment system. In its simplest form a clarifier includes a tank into which wastewater is pumped through a pipe, also known as a downcomer. The outlet of the downcomer is submerged in a slurry mixture and introduces wastewater into the slurry. The particulates in the wastewater get trapped in the slurry while the water siphons through and
15 eventually the clarified water is collected in a launder at the top of the tank. An outlet at the bottom of the tank is used to drain the slurry containing the particulates. In such a conventional clarifier a rise or overflow rate of about 4 m/s is achieved.

A flocculent is usually also introduced into the clarifier to induce a process wherein particulates or
20 colloids come out of suspension in the form of floccules or flakes. Flocculation treatment systems employ a physical/chemical process and remove mostly particulates and colloidal solids present in the wastewater. The floccules get trapped in the slurry and are ultimately drained from the tank through the slurry outlet.

25 A disadvantage of the conventional clarifiers is that the low overflow rates result in large tanks being used to achieve an acceptable volumetric flow rate. This, in turn, has adverse cost implications.

30 There have been many developments in the field of clarifiers to improve overflow rates in an attempt to reduce the overall size of the tank. One known development was to mount concentric rings or pipes, typically two, around the outlet end of the downcomer. In a further improvement the outermost ring was redesigned to resemble a clarifier. By mounting a number of these outer rings in the main tank a configuration was created wherein a number of reactors, which in principle act as



-2-

smaller clarifiers, are mounted inside the clarifier. This configuration resulted in higher overflow rates being achieved and, accordingly, smaller tanks being used to obtain the required volumetric flow rates. Although higher overflow rates have been obtained in clarifiers incorporating this configuration, they are still not designed optimally.

5

It has generally been believed that in order for flocculation to take place the process has to be performed under calm conditions due to the fragile nature of the flocculent molecules. Due to this belief, wastewater is introduced into the tanks of the prior art clarifiers at relatively low flow rates as these clarifiers are designed to avoid turbulent water flow. This is one of the reasons why the systems currently known in the art are not designed optimally.

10

It is an object of this invention to alleviate at least some of the problems experienced with existing water treatment apparatus.

15 It is a further object of this invention to provide a water treatment apparatus that will be a useful alternative to existing apparatus.

20 SUMMARY OF THE INVENTION

According to a first aspect of the invention there is provided a reactor for use in a clarifier of a water treatment system, the reactor including:

25 a body for receiving a stream of wastewater from a feed line of the clarifier, the body having a first opening which is, in use, an upper opening through which clarified water is released and second opening which is, in use, a lower opening through which slurry is dispensed;

means for accelerating the wastewater stream introduced into the body, the accelerating means being located below the outlet of the feed line so that the stream of wastewater entering the reactor is accelerated after having been dispensed through the outlet of the feed line.;

30 and

a diverting formation which is positioned in line with the accelerated stream of wastewater so that the wastewater stream strikes the diverting formation after having been accelerated.



The acceleration means may be in the form of a venture.

5 The venturi is preferably positioned relative to the feed line so that, in use, the top of the venturi is at least level or below the outlet of the feed line.

In the preferred embodiment the diverting formation is profiled to divert the incoming stream of wastewater radially outwards. Preferably, the diverting formation is profiled to divert the wastewater stream in a radially outward and upward direction.

10

The reactor may further include a deflecting arrangement located about the diverting formation and positioned to increase the boundary layer on an inside surface of the body.

According to a second aspect of the invention there is provided a clarifier including:

- 15 a primary tank;
a feed line for introducing wastewater into the tank;
a slurry outlet located in a lower region of the tank through which slurry is drained from the tank;
an overflow launder located to catch clarified water dispensed at an upper region of the
20 tank; and
a reactor which is fed by the feed line, the reactor being a reactor according to the first aspect of the invention.

25 The clarifier may include a number of supply tanks supplying a number of reactors by means of individual feed lines running from each supply tank to an associated reactor. Alternatively, the clarifier may include a central supply tank supplying a number of reactors by means of feed lines running from the supply tank to each reactor. The supply tank or tanks are preferably located completely outside the primary tank.

30 According to a third aspect of the invention there is provided a method of clarifying wastewater in a reactor of a clarifier, the method including the following steps:

introducing a wastewater stream into the reactor through a feed line;



-4-

accelerating the wastewater stream using an acceleration means after it has been introduced into the reactor;

diverting the accelerated wastewater stream in a radially outward direction;

5 catching particulates present in the wastewater in a boundary layer created on an inside surface of the reactor body;

draining the particulates through a slurry outlet in the reactor body; and

collecting clarified water.

10 The step of diverting the accelerated stream of wastewater radially outwards preferably includes diverting the wastewater stream at an upward angle.

The method preferably includes the step of recycling the particulates which were not caught in the boundary layer through the acceleration means.

15 The method may include the step of introducing a flocculent in the water so that a flocculation process takes place inside the reactor.

20 **BRIEF DESCRIPTION OF THE DRAWINGS**

The invention will now be described in more detail, by way of example only, with reference to the accompanying drawings in which:

25 **Figure 1** shows a diagrammatic representation of a prior art clarifier;

Figure 2 shows a diagrammatic representation of a clarifier according to the invention;

Figure 3 shows a cross sectional view of a reactor according to the invention; and

30



-5-

Figure 4 shows a cross sectional view of a reactor according to a second embodiment of the invention.

5

DESCRIPTION OF THE ILLUSTRATED EMBODIMENT

Figure 1 shows a diagrammatic representation of a prior art clarifier 100 as described above. The clarifier 100 includes a tank 102 and a number of reactors 104 which each has an outer ring or body 106, an inner ring 108 and a diverting formation 110. Only one reactor is shown in Figure 1. The reactor 104 is supplied with wastewater from a supply tank 112 via a supply line 114, also known as a downcomer. The wastewater is supplied into the reactor 104 through an outlet 116 of line 114.

15 The body 106 tapers towards a slurry outlet 118 which is located at the bottom of the ring and through which the slurry exits the reactor. The clarified water is, in turn, dispensed at the top of the body 104. The clarified water rises all the way to the top of the tank 101 until it eventually flows over the edge of the tank and into launders 120. The slurry eventually exits the clarifier 100 through a primary outlet 122 located at the bottom of tank 103.

20

The configuration of components inside the reactor 104 allows slurry to build up inside the reactor to such an extent that the majority of the body 106 is filled with slurry. The slurry level inside the reactor is shown in broken lines in Figure 1.

25 Figure 2 shows a diagrammatical representation of a clarifier 10 according to the invention. The clarifier 10 is typically part of a water treatment system which is used to clarify wastewater in a flocculation process. The clarifier 10 includes a primary tank 12 which houses a number of reactors 30 of which only one is shown in the figures. Each reactor is supplied with wastewater from a supply tank 14 via a feed line or downcomer 16. The wastewater is introduced into the reactor 30 through an outlet 18 of line 16.

30

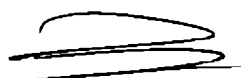

-6-

Each reactor 30 has a body 32 for receiving the stream of wastewater from the feed line 16, means 34 for accelerating the wastewater stream and a diverting formation 36 for diverting the incoming stream of wastewater.

5 As shown in Figure 2 the body 30 has a first opening which is, in use, an upper opening 38.1 through which clarified water is released and second opening which is, in use, a lower opening 38.2 through which slurry exits the body. In the preferred embodiment the body 32 tapers down towards the lower opening 38.2, also referred to as the slurry outlet. In the clarification process the particulates in the wastewater eventually exit the tank 12 through a primary outlet 22 located at the
10 bottom of tank, while the clarified water rises all the way to the top of the tank until it eventually flows over the edge and into launders 20.

The reactor 30 is shown in greater detail in Figure 3. From this figure it can be seen that the outlet 18 of the feed line 16 is located inside the body 32. In the preferred embodiment the body is largely
15 cylindrical and located concentrically about the feed line 16 and, accordingly, the wastewater entry flow direction, which is indicted by the reference sign A.

The acceleration means 34 accelerates the wastewater inlet stream introduced into the body. As can be seen in Figure 3 the acceleration means 34 is shaped to form a neck formation 40 which
20 narrows the diametrical flow area through which the wastewater stream is allowed to flow. This shape is also commonly referred to a venturi and according to the venturi effect the velocity of the wastewater stream will increase as a result of the decrease in diametrical flow area. The venturi 34 is located below the feed line outlet 18 so that the stream of wastewater entering the body 32 is accelerated after having been dispensed through the feed line outlet. In the illustrated embodiment
25 the venturi 34 is positioned relative to the feed line so that in use its top is at least level or below the feed line outlet 18. It is however envisaged that in alternative embodiments the venturi 34 may be positioned so that the outlet 18 is located inside the venture but above the neck formation 40.

The velocity of the wastewater inlet stream is increased in order to increase the speed at which the
30 wastewater stream strikes the diverting formation 36. It must be understood that the velocity of the stream must be sufficiently high so that the particulates therein are thrown radially outward by the diverting formation 36 towards the sidewall of the body 32. In the preferred embodiment the diverting formation 36 is profiled so as to divert the wastewater stream in a radially outward and upward direction. The diverting formation has a disc-like shape with its outer profile being circular.



-7-

As shown in Figure 3, the thickness of the disc-like diverting formation 36 reduces radially outward before increasing again near its outer extremity so that the wastewater is deflected at an upward angle when leaving the diverting formation. The flow direction caused by the diverting formation 36 is indicated by reference sign B in Figure 3.

5

A person familiar with fluid mechanics will know that the flow of fluid in the body 32 will create a boundary layer 42 in the immediate vicinity of the inside surface of the body as a result of the effects of viscosity of the fluid. The boundary layer 42 is shown in broken lines in Figure 3.

10 During the water clarification process the particulates in the inlet wastewater stream will be thrown towards the boundary layer 42. It will be understood that the larger and heavier particulates will be thrown farther than the smaller and lighter particulates. Ideally the heavier particulates will be thrown into the boundary layer 42 where it will be captured and gradually move down towards the slurry outlet 38.2. The movement of the captured particulates in the boundary layer is indicated by
15 reference sign C. The lighter particulates will rise in the annular space between the venturi 34 and sidewall of the body 32 until the suction forces created by the venturi will cause the particulates to be drawn through the venturi again. The flow direction of the particulates at the top of the venturi 34 is indicated by reference sign D.

20 A flocculent is also introduced into the wastewater stream in the water treatment cycle. As mentioned above, the flocculent will cause the particulate material to come out of suspension in the form of floccules or flakes. The fluid flow pattern inside the reactor 30 will cause the particulates to be recycled through the venturi until they have reached a sufficient size to be thrown into the boundary layer 42. The flocculation process taking place inside the reactor ensures that the
25 floccules reach a sufficient size as they are recycled through the venturi.

It should be clear that while the particulates in the wastewater get recycled in the reactor 32, the clarified water escapes through the upper opening 38.1 of the reactor and flows towards the top of the tank 12 as indicated by reference sign E.

30

Figure 4 shows another embodiment 50 of the reactor. In this figure like references designate like features.



-8-

In this second embodiment 50 of the reactor the boundary layer 42 is increased in order to increase the efficiency of the reactor. By increasing the boundary layer 42 smaller sized particulates or floccules will be caught therein, thus resulting in floccules being recycled a fewer number of times through the venturi. As a result the efficiency of the water clarifying process is increased and, accordingly, the overflow rate of the clarifier.

The boundary layer 42 is increased by inserting a boundary layer deflecting arrangement 52 in the reactor 50. In the preferred embodiment the deflecting arrangement 52 is in the form of a circular ring and located about the diverting formation 36. The location of the deflecting arrangement 52 is critical in that the boundary layer 42 must be drawn away from the inner surface of the body 32 as shown in Figure 4. If the deflecting arrangement 52 is located too far away from the inner surface of the body 32, the boundary layer will simply follow the inner surface without being deflected. Ideally the position of the deflecting arrangement must be set according to the flow parameters in the reactor 50 so that a maximum amount of boundary deflection is achieved.

Returning now to Figure 2, it can be seen that the wastewater supply tank 14 is lifted out of the primary tank 12 seeing that, in a water clarification process as described above, a large extent of the monitoring is done visually. By lifting the wastewater supply tank 14 above the water level in the primary tank 12, visual monitoring is improved. Another advantage of lifting the supply tank 14 out of the primary tank 12 is that the surface area available for reactor fitment is increased, thereby allowing an increased number of reactors inside the tank 12.

Although each reactor 30, 50 in the illustrated embodiments is supplied by a corresponding wastewater supply tank 14, it is envisaged that a single supply tank could be used to supply wastewater to all of the reactors. In the event of a central supply tank being used, the reactors are supplied with wastewater via separate supply lines running from the central tank.

Although the method of clarifying wastewater in the clarifier 10 should be clear from the above description, it will now be set out briefly. Firstly, a stream of wastewater is introduced into the body 32 of the reactor 30, 50 through the feed line 16. Thereafter the wastewater stream is accelerated before striking the diverting formation 36. As a result of the stream striking the formation 36, it is diverted in a radially outward and upward direction. The heavier particulates present in the wastewater is then caught in the boundary layer created on the inside surface of the reactor body 32. The captured particulates are transported down to the slurry outlet 38.2 at the bottom of the



-9-

reactor body 32 while the clarified water is released through the upper opening 38.1 of the body. The clarified water is eventually collected in the launder 20 at the top of the tank 12 while the particulates exit the tank 12 through the outlet 22.

5 It must be understood that the lighter particles, which are not caught in the boundary layer after having been thrown out radially by the diverting formation, are recycled through the venturi 34 until they reach a sufficient weight to be caught in the boundary layer. The method also includes the step of adding a flocculent in order to increase the size and weight of the particles while they are being recycled through the venturi.

10

The method further includes the step of increasing the boundary layer by adding a deflecting arrangement about the diverting formation.

15 An advantage of using the clarifier 30, 50 according to the invention is that the overflow rates and therefore the efficiency of the clarifier are increased as a result of the increase in velocity of the wastewater stream and the increase in the size of the boundary layer.

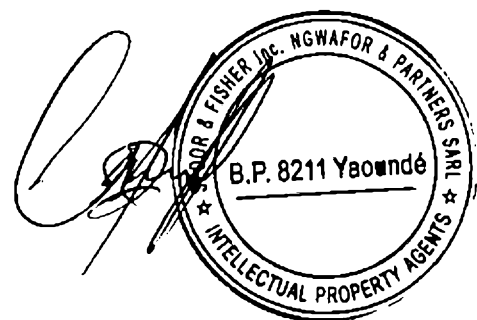

CLAIMS

1. A reactor for use in a clarifier of a water treatment system, the reactor including:
- 5 a body for receiving a stream of wastewater from a feed line of the clarifier, the body having a first opening which is, in use, an upper opening through which clarified water is released and second opening which is, in use, a lower opening through which slurry is dispensed;
- 10 means for accelerating the wastewater stream introduced into the body, the acceleration means being located below the outlet of the feed line so that the stream of wastewater entering the reactor is accelerated after having been dispensed through the outlet of the feed line; and
- 15 a diverting formation which is positioned in line with the accelerated stream of wastewater so that the wastewater stream strikes the diverting formation after having been accelerated.
2. A reactor according to claim 1, wherein the acceleration means is in the form of a venturi positioned relative to the feed line so that, in use, the top of the venturi is at least level or below the outlet of the feed line.
- 20 3. A reactor according to either claim 1 or 2, wherein the diverting formation is profiled to divert the incoming stream of wastewater in a radially outward and upward direction.
4. A reactor according to any one of the preceding claims, including a deflecting arrangement located about the diverting formation and positioned to increase the boundary layer on an
- 25 inside surface of the body.
5. A clarifier including:
- a primary tank;
- a feed line for introducing wastewater into the tank;
- 30 a slurry outlet located in a lower region of the tank through which slurry is drained from the tank;



-11-

an overflow launder located to catch clarified water dispensed at an upper region of the tank; and

a reactor which is fed by the feed line, the reactor being a reactor according to any one of claims 1 to 4.

5

6. A clarifier according to claim 5, including a number of supply tanks supplying a number of reactors by means of individual feed lines running from each supply tank to an associated reactor.

10 7. A clarifier according to claim 6, including a central supply tank supplying a number of reactors by means of feed lines running from the supply tank to each reactor.

8. A clarifier according to either claim 8 or 9, wherein the supply tank or tanks are located completely outside the primary tank.

15

9. A method of clarifying wastewater in a reactor of a clarifier, the method including the following steps:

introducing a wastewater stream into the reactor through a feed line;

20 accelerating the wastewater stream using an acceleration means after it has been introduced into the reactor;

diverting the accelerated wastewater stream in a radially outward direction;

catching particulates present in the wastewater in a boundary layer created on an inside surface of the reactor body;

draining the particulates through a slurry outlet in the reactor body; and

25

collecting clarified water.

10. A method according to claim 11, wherein the step of diverting the accelerated stream of wastewater radially outwards includes diverting the wastewater stream at an upward angle.

30 11. A method according to either claims 11 or 12, including the step of recycling the particulates which were not caught in the boundary layer through the acceleration means.



12. A method according to any one of claims 11 to 13, including the step of introducing a flocculent in the water so that a flocculation process takes place inside the reactor.

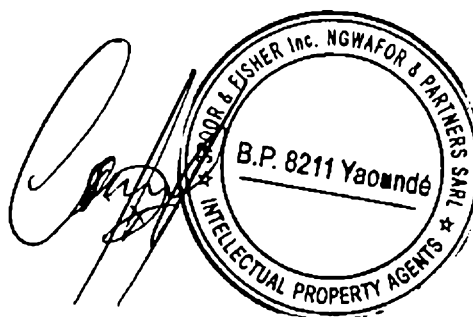

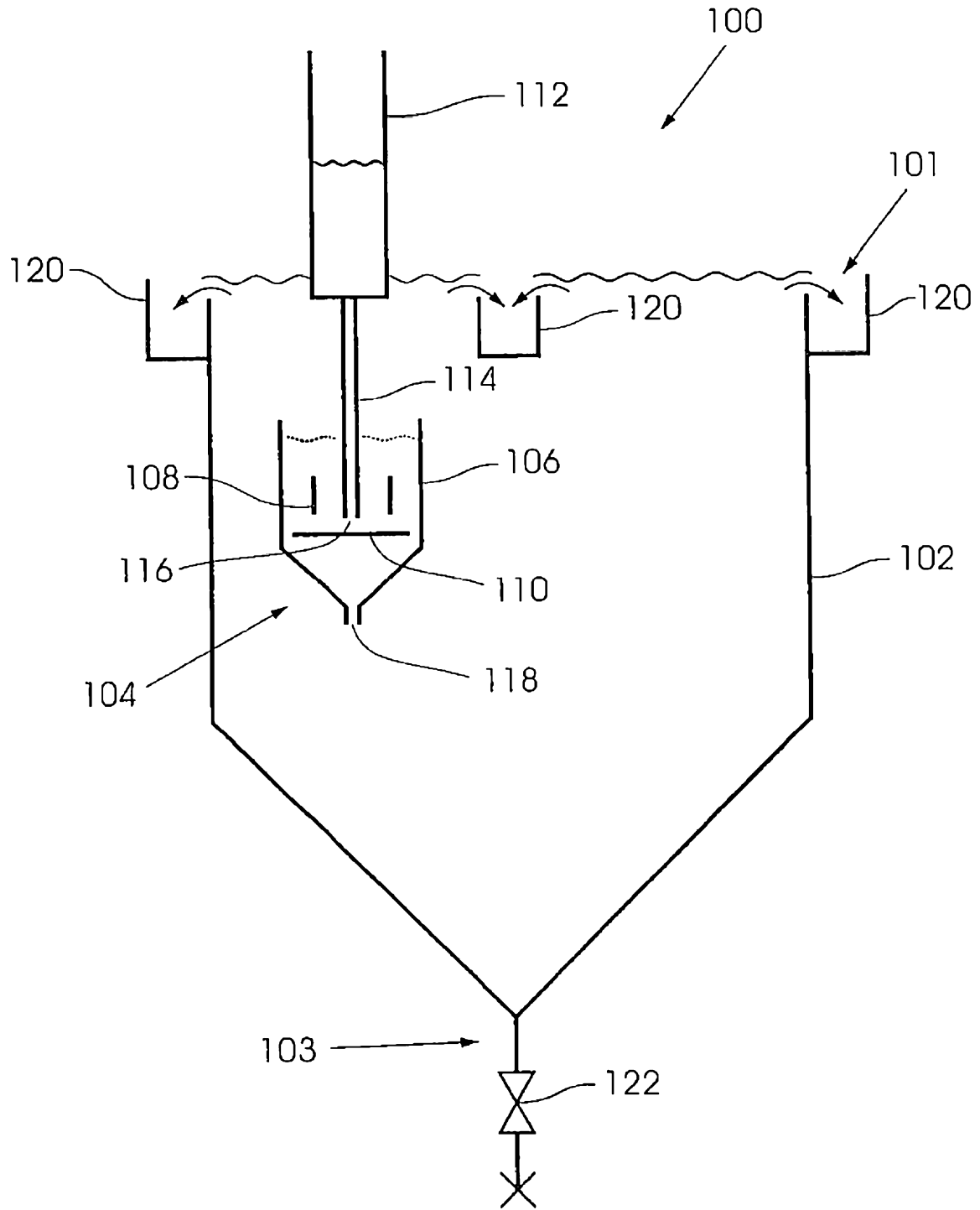

Fig. 1
(PRIOR ART)

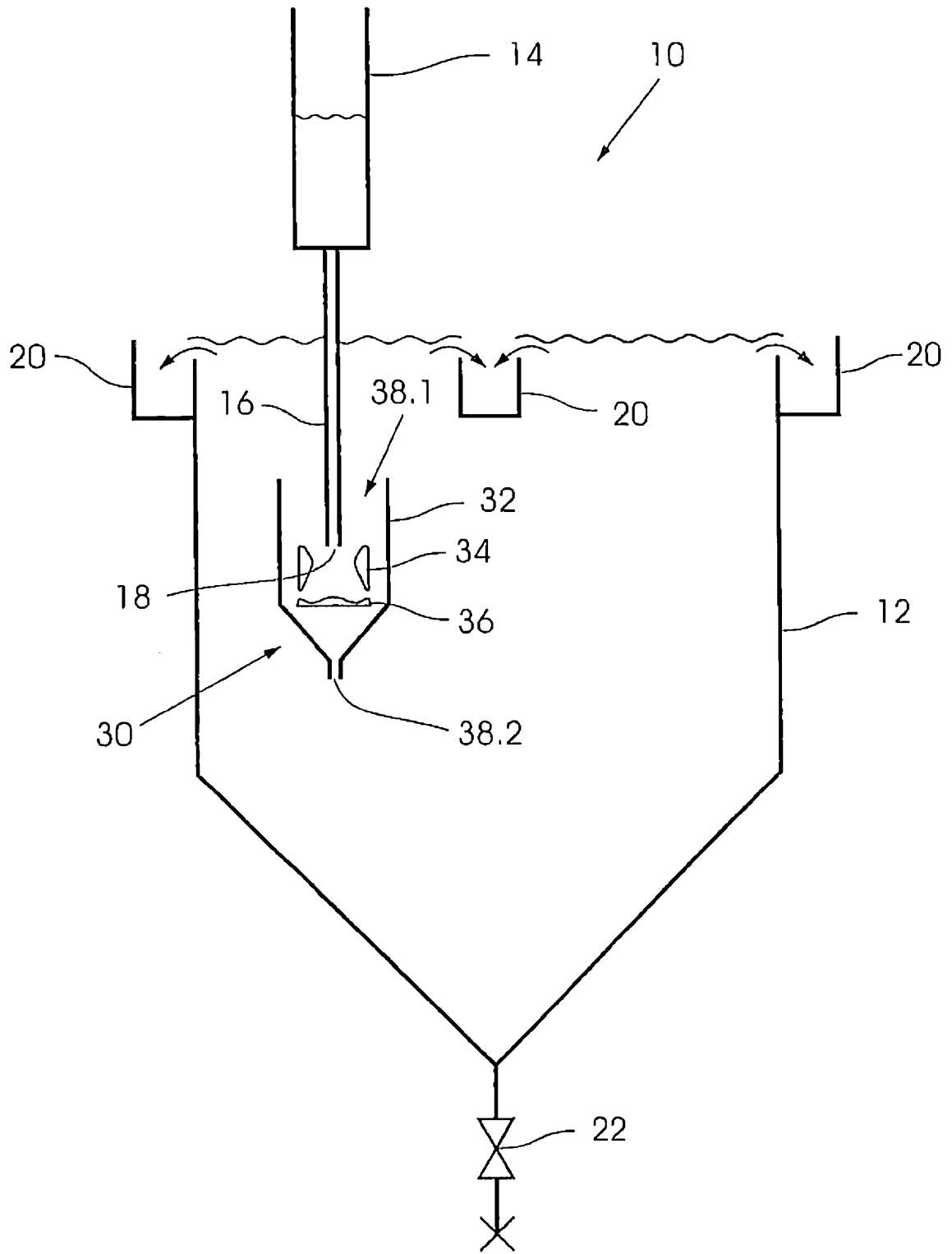

Fig. 2

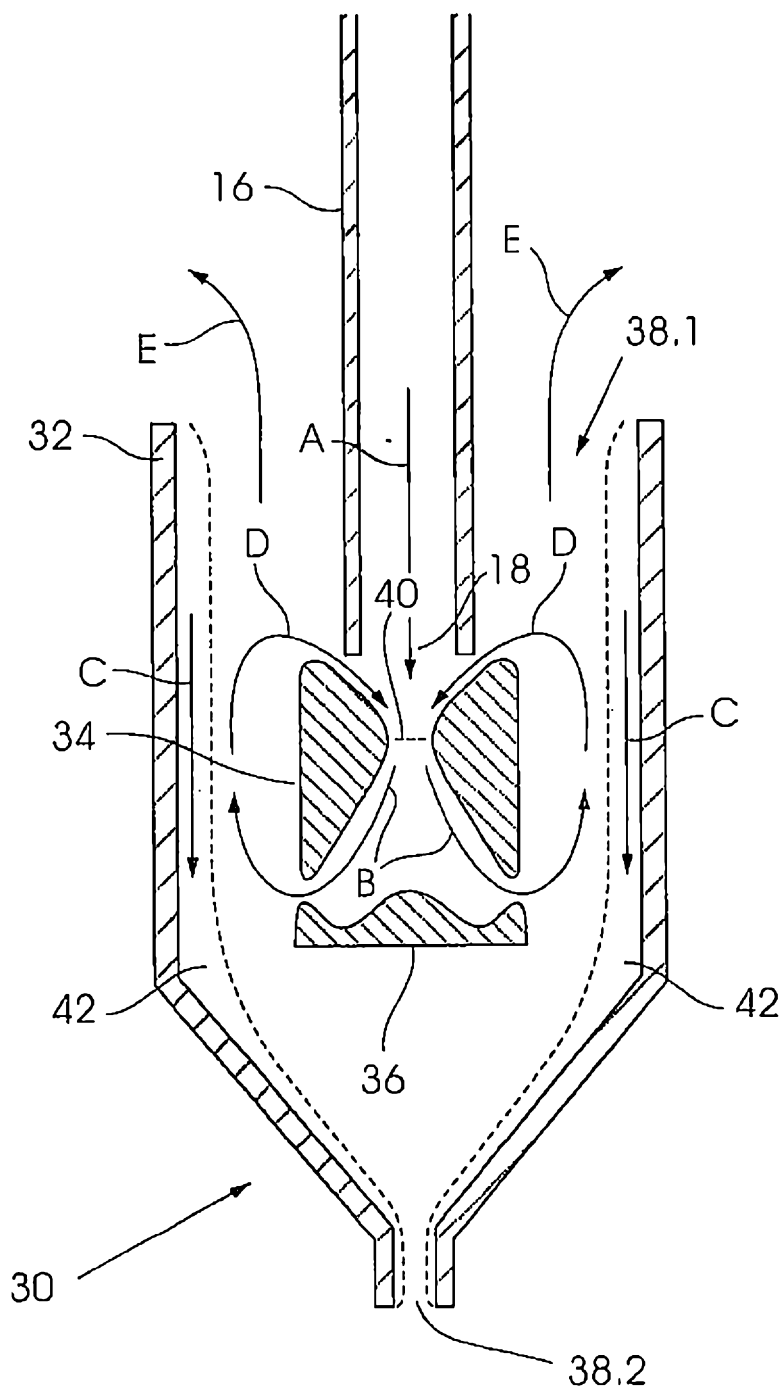

Fig. 3

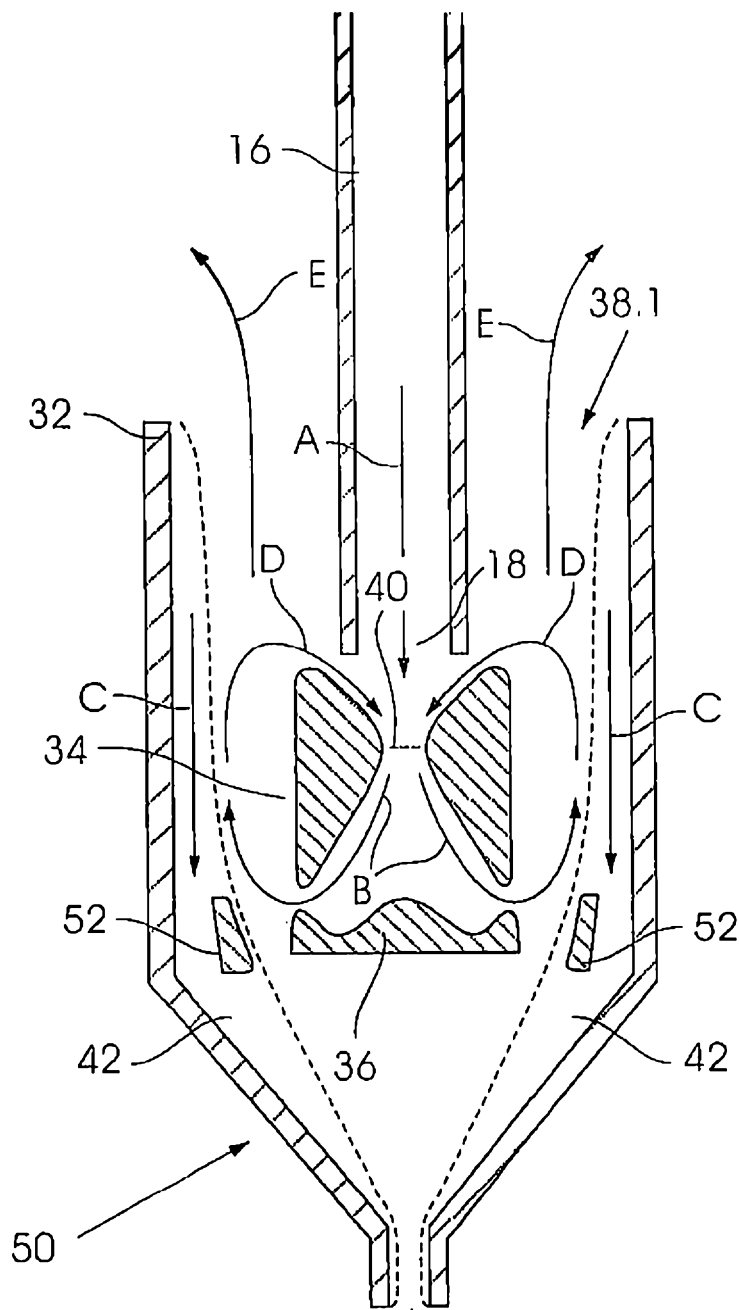

Fig. 4

