

(19) World Intellectual Property Organization
International Bureau



(43) International Publication Date
23 December 2010 (23.12.2010)

(10) International Publication Number
WO 2010/147543 A1

- (51) **International Patent Classification:**
F16H 63/20 (2006.01) *F16H 61/32* (2006.01)
- (21) **International Application Number:**
PCT/SE2010/050664
- (22) **International Filing Date:**
14 June 2010 (14.06.2010)
- (25) **Filing Language:** Swedish
- (26) **Publication Language:** English
- (30) **Priority Data:**
0950469-7 17 June 2009 (17.06.2009) SE
- (71) **Applicant (for all designated States except US):** SCANIA CV AB [—/SE]; S-151 87 Södertälje (SE).
- (72) **Inventor; and**
- (75) **Inventor/Applicant (for US only):** HAGBERG, Magnus [SE/SE]; Pershagsvägen 10, S-151 39 Södertälje (SE).
- (74) **Agent:** WESTMAN, Mimmi; Scania CV AB, S-151 87 Södertälje (SE).
- (81) **Designated States (unless otherwise indicated, for every kind of national protection available):** AE, AG, AL, AM,

AO, AT, AU, AZ, BA, BB, BG, BH, BR, BW, BY, BZ, CA, CH, CL, CN, CO, CR, CU, CZ, DE, DK, DM, DO, DZ, EC, EE, EG, ES, FI, GB, GD, GE, GH, GM, GT, HN, HR, HU, ID, IL, IN, IS, JP, KE, KG, KM, KN, KP, KR, KZ, LA, LC, LK, LR, LS, LT, LU, LY, MA, MD, ME, MG, MK, MN, MW, MX, MY, MZ, NA, NG, NI, NO, NZ, OM, PE, PG, PH, PL, PT, RO, RS, RU, SC, SD, SE, SG, SK, SL, SM, ST, SV, SY, TH, TJ, TM, TN, TR, TT, TZ, UA, UG, US, UZ, VC, VN, ZA, ZM, ZW.

- (84) **Designated States (unless otherwise indicated, for every kind of regional protection available):** ARIPO (BW, GH, GM, KE, LR, LS, MW, MZ, NA, SD, SL, SZ, TZ, UG, ZM, ZW), Eurasian (AM, AZ, BY, KG, KZ, MD, RU, TJ, TM), European (AL, AT, BE, BG, CH, CY, CZ, DE, DK, EE, ES, FI, FR, GB, GR, HR, HU, IE, IS, IT, LT, LU, LV, MC, MK, MT, NL, NO, PL, PT, RO, SE, SI, SK, SM, TR), OAPI (BF, BJ, CF, CG, CI, CM, GA, GN, GQ, GW, ML, MR, NE, SN, TD, TG).

Published:

— with international search report (Art. 21(3))

(54) **Title:** DEVICE FOR THE AUTOMATIC OPERATION OF A MANUAL GEAR BOX

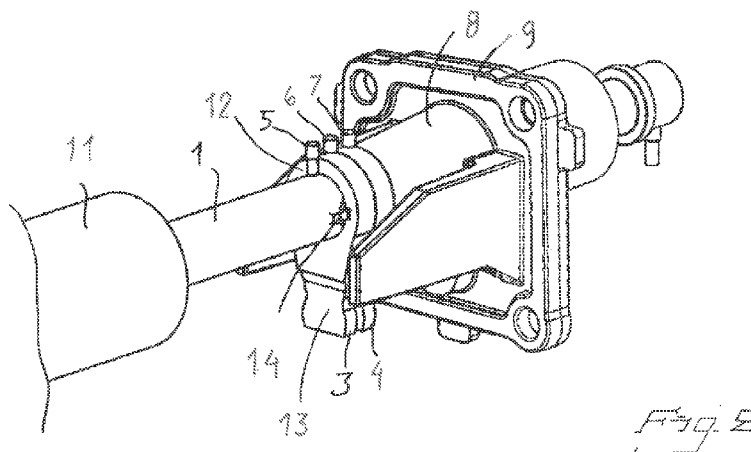

(57) **Abstract:** The invention relates to an operating device for an automatically switched manual gearbox. The gearbox is provided with a movable engagement element for each gear. The operating device is provided with rotary shafts (1) and rotatable shift fingers (2, 3, 4) to move selected engagement elements. According to the invention, the shift finger means (2, 3, 4) comprise a number of separate shift fingers (2, 3, 4) each associated with a specific engagement element. Each shift finger (2, 3, 4) is adapted to being separately pivotable independently of the other shift fingers (2, 3, 4).

WO 2010/147543 A1

DEVICE FOR THE AUTOMATIC OPERATON OF A MANUAL GEAR BOX

Field of the invention

The present invention relates to an operating device for an automatically switched
5 manual gearbox, said gearbox being provided with a movable engagement
element for each gear and said operating device being provided with rotary shafts
and pivotable shift finger means for movement of selected engagement elements.

Background to the invention

10 A commonly occurring configuration in automatically switched manual gearboxes
is that respective gears are engaged or disengaged by moving an engagement
element, usually in the form of a shaft. The engagement element has a notch or
yoke-like shoulder acted upon by a shift finger which engages in the notch and
pushes the engagement element in the respective direction for engagement or
15 disengagement of the gear.

The shift finger effects this movement by being pivoted about a rotary
shaft. This entails the shift finger and the pivoting operating shaft being first moved
axially so that the shift finger is located axially to the position for cooperation with
the respective engagement shaft.

20 The axial movement of the rotary shaft with the shift finger involves the
application of a relatively large force, normally by use of pneumatic or hydraulic
power means. Gear changing therefore tends to be cumbersome and imprecise.

Gearboxes of this kind are described inter alia in US 20040154419, US
20020189388, US 2001037698 and FR 2860567.

25 US20040154419A1 describes a mechanism for gearbox operation
whereby a solenoid or an electric motor pivots a shaft and a pulling solenoid which
can turn away the shift fingers, two or more fingers in a package, depending on
which gear is to be engaged in the gearbox. The turning away is to prevent any
double gear change, i.e. simultaneous engagement of two selector shafts. The
30 turning away takes place axially along the selector shaft which transmits a pivoting
movement and an axial movement.

US20020189388A1 is a gear change mechanism based entirely on
solenoids and only one shift finger and using solenoids to switch the shift finger to
seven different positions. There are three solenoids to effect this switching.

US2001037698 describes a shift finger which is pivoted by solenoids.

FR 2860567 describes a number of shift fingers which can be engaged individually relative to one another, with a slide which prevents an incorrect gear from being engaged when the others are to be operated, a kind of locking slide.

5 The object of the present invention is to propose an operating device of the kind here concerned whereby the disadvantages described above are eliminated, which device thus makes it possible for engagement and disengagement of a gear to take place more smoothly and simply than is possible in the state of the art.

10

Summary of the invention

The object stated is achieved according to the invention by an operating device of the kind indicated in the introduction having the special features that the shift finger means comprises a number of separate shift fingers, each of them
15 associated with a specific engagement element and adapted to being separately pivotable independently of the other shift fingers.

Separate and independent operation of each shift finger eliminates the need to move any shift fingers axially in relation to engaging or disengaging a gear. In principle, the shift fingers and also the rotary shaft may thus be so
20 arranged that they are not movable axially. This makes the gearbox easier to operate and results in greater precision. The force to be applied becomes smaller and the force required in the axial direction of the rotary shaft is reduced significantly or eliminated. The power equipment can therefore be simplified and configured without pneumatic means. Eliminating the need to be able to move the
25 shift fingers axially also renders the configuration of the operating device simpler than known similar devices.

According to a preferred embodiment, the shift fingers are fitted axially after one another along a rotary shaft which is movable axially to assume various operating positions, in each of which the rotary shaft is connected to, for joint
30 rotation with, only one of the shift fingers and is pivotable relative to the other shift fingers.

This version provides a very simple solution for effecting the pivoting movement in that the same shaft is used for operating all of the shift fingers. It also eliminates the need to effect axial movement of any part of the operating device.

According to a further preferred embodiment, the rotary shaft extends through a hole in each shift finger, each hole having at least one groove running axially through it, and the rotary shaft is provided with at least one radial protrusion for pivoting cooperation with respective grooves in at least one of the shift fingers
5 depending on the operating position of the rotary shaft.

The result is the establishment of a spline-like connection between the rotary shaft and the respective shift finger and hence effective and reliable transmission of the pivoting movement. Movement of the rotary shaft is a simple way of putting its protrusions into pivoting cooperation with the shift finger which is
10 related to an intended gear.

According to a further preferred embodiment, each shift finger is provided with an indexing element which is urged towards the rotary shaft by a respective spring, and the rotary shaft is provided with a hollow adapted to being able to accommodate any of the indexing elements.

The indexing element facilitates the axial positioning of the rotary shaft so that it reaches correct positions for pivoting of intended shift fingers. When the hollow is moved axially to position for one of the indexing elements, the spring will snap the indexing element into the hollow, thereby indicating correct axial position relative to the shift finger for effecting pivoting for gear change. Upon axial
15 movement from this position in order to engage another gear, the indexing element is pushed up out of the notch against the action of the spring and abuts against the periphery of the rotary shaft.

With advantage, the indexing element takes the form of a ball or is of spherical configuration on at least its side which faces towards the rotary shaft,
25 and the hollow is of corresponding spherical shape. The snapping in and pushing out of the indexing element are thus facilitated.

According to a further preferred embodiment, the shift fingers are fitted axially after one another along a rotary shaft package which comprises a number of coaxial rotary shafts which are pivotable relative to one another and are each
30 connected to, for joint rotation with, a particular shift finger.

This alternative embodiment eliminates the need to provide a locking mechanism for firm locking of the respective shift fingers, which in this respect represents a simplification. Gear selection is effected by pivoting a selected one of the rotary shafts.

According to a further preferred embodiment, each rotary shaft is provided with a radially protruding pivot element connected to, for joint rotation with, the rotary shaft, and these pivot elements are located axially after one another along the rotary shaft package.

5 The pivot elements facilitate pivoting of the respective rotary shafts. The fact that they are axially separate also makes it easy to pivot only one of the rotary shafts. With advantage, each pivot element takes the form of a radial pin.

According to a further preferred embodiment, the device comprises a slide which is movable axially, pivotable on the rotary shaft package and provided with
10 shoulder elements adapted to pivoting action upon selected pivot elements according to the axial position of the slide.

The slide and the pivot elements constitute a simple, robust and reliable mechanism for engagement of gears. Gear selection is by moving the slide so that its shoulder elements come into position to act upon respective pivot elements.
15 Relevant shift fingers can thereafter easily be pivoted via their associated rotary shafts by pivoting the slide.

According to a further preferred embodiment, the slide takes the form of a cut cylinder supported on the outermost of the rotary shafts and has an opening running axially which comprises a first section with a smaller peripheral width and
20 at least one second section with a larger peripheral width, smaller and larger peripheral width being defined by the difference in angular extent being at least twice as great as the angular movement of a shift finger which is required to engage or disengage a gear.

The shoulder elements of a slide thus configured will be of very simple
25 construction since the edges of the smaller section of the opening will themselves serve as shoulder elements. The greater width of the remainder of the opening makes it possible for the pivoting of the slide to take place without affecting the pivot elements of any of the other rotary shafts.

According to a further preferred embodiment, the opening comprises two
30 sections with the larger width, each situated axially on its respective side of the section with the smaller width.

The maximum axial movement of the slide required to engage a gear is thus minimised.

According to a further preferred embodiment, the smaller width corresponds to an angle within the range 5-10° and the larger width to an angle within the range 120-175°.

The relative definition of smaller and larger width indicated above is normally fulfilled within this angle range. The smaller width has to be at least as large as the peripheral extent of each pivot element, with a certain tolerance to avoid disruption of axial relative movement between pivot element and slide. The range indicated is advantageous in this respect. A larger width within the range indicated will then result in a good margin as regards space for gear change movement in either direction. The fact that the larger width is less than 180° provides assurance of the slide's centring about the rotary shaft package.

According to a further preferred embodiment, the operating device comprises a solenoid or an electric motor adapted to pivoting the rotary shaft/one of the rotary shafts.

The operating device invented makes it possible for only a relatively small amount of force to have to be applied to engage or disengage a gear. This embodiment takes advantage of the possibility of dispensing with pneumatic or hydraulic operation. The device thereby becomes particularly simple and reliable.

The invention relates also to a gearbox provided with an operating device in accordance with the invention, particularly according to any of its preferred embodiments.

The invention further relates to a motor vehicle provided with the invented gearbox.

The invented gearbox and the invented motor vehicle afford advantages of similar kinds to the invented operating device and its preferred embodiments, which advantages are described above.

Advantageous embodiments indicated above of the invention are indicated in the claims which depend on claim 1. It should be noted that further preferred embodiments may of course take the form of all conceivable combinations of the preferred embodiments indicated above.

The invention is further explained by the detailed description set out below of some examples of an operating device according to the invention, with reference to the accompanying drawings.

Brief description of the drawings

Fig. 1 is a side view of an operating device according to a first embodiment example of the invention.

Fig. 2 is a perspective view of part of the operating device in Fig. 1.

5 Fig. 3 is a section through a detail of the operating device in Fig. 2.

Fig. 4 is a perspective view of an operating device according to a second embodiment example.

Fig. 5 is a view from above of a detail of the operating device in Fig. 4.

Fig. 6 is a section along the line VI-VI in Fig. 5.

10 Fig. 7 is a longitudinal section through a detail of the operating device in Fig. 4.

Fig. 8 illustrates schematically a gearbox with operating device according to the invention.

Fig. 9 illustrates schematically a vehicle provided with a gearbox according to Fig. 8.

15

Description of the embodiment examples

Fig. 1 depicts an operating device according to the invention in a side view in which a rotary shaft 1 is provided with a number of, in this example three, shift fingers 2, 3, 4. Each of the shift fingers is adapted to being connectable to, for joint rotation with, the rotary shaft 1 by means of a spline-like connection. When one of the shift fingers is connected firmly to, for joint rotation with, the rotary shaft 1, the other two are free-running. Pivoting of the rotary shaft 1 therefore causes whichever of shift fingers 2, 3, 4 is connected for joint rotation to pivot, whereupon its portion which protrudes downwards in the diagram will move out perpendicular to the plane of the paper. The other two shift fingers will be stationary. The pivoted shift finger is connected to an undepicted engagement shaft running perpendicular to the plane of the paper and moves the engagement shaft to engage or disengage one of the gears in an undepicted gearbox.

Ref. 11 denotes a drive unit for axial movement of the rotary shaft 1. The drive unit 11 is with advantage a solenoid or an electric motor. Ref. 10 symbolises the drive mechanism for rotating the rotary shaft.

Fig. 2 depicts the right portion of Fig. 1 in a perspective view with one of the shift fingers removed to make certain details clearer. Each shift finger 3, 4 comprises a circular portion 12 surrounding the rotary shaft 1 and a finger portion

13 which protrudes from the circular portion 12 and is flat-shaped. Each shift finger has in its circular portion a radial hole which accommodates a respective indexing mechanism 5, 6, 7 described in more detail in relation to Fig. 3. The rotary shaft 1 has two protrusions 14, only one of which is visible in Fig. 2, the other being
5 situated on the diametrically opposite side. Each protrusion 14 takes the form of a ridge 14 running axially with an axial extent which is somewhat smaller than thickness of a shift finger.

Fig. 3 depicts the middle shift finger 3 in a section transverse to the axial direction, the shift finger 3 being axially positioned centrally to the rotary shaft's
10 protrusions 14. The shift finger 3 has two grooves 15 disposed diametrically and shaped to complement the protrusions 14. A spline-like connection is thus established between the rotary shaft 1 and the shift finger 3 which is positioned axially with its grooves 15 cooperating with the protrusions 14.

The indexing mechanism 5 comprises a spring 17 which urges an indexing
15 element 16 in the form of a ball 16 towards the rotary shaft. The rotary shaft 1 is provided with a spherical hollow 18 adapted to being able to accommodate the ball 16. In the position depicted, the ball 16 is pressed into the hollow 18. The rotary shaft's hollow 18 is axially situated centrally to the shaft's ridges 14.

Gear changing takes place as follows with reference to Figs. 2 and 3. In a
20 neutral state, the shift fingers 2, 3, 4 are situated centrally to one another so that their respective grooves 15 form a composite groove. In this state, the rotary shaft 1 is so positioned that its ridges 14 are situated centrally to the grooves 15 of the shift fingers. The hollow 18 of the rotary shaft 1 is also axially situated centrally to the ball 16 of one of the shift fingers, with advantage the middle shift finger 3.

25 If the gear which is engaged by means of the shift finger 4 is to be activated, the rotary shaft is moved axially to the right in Fig. 2. This results in its ball 16 being pushed out from the hollow 18 and sliding axially on the periphery of the rotary shaft. When the axial movement has caused the hollow 18 to reach the shift finger 4 on the right in the diagram, the latter's ball snaps into the hollow 18
30 and a distinct axial position thus becomes indexed. During the movement, the ridges 14 of the rotary shaft move to engage in the corresponding notches of the right shift finger 4.

In this position, the rotary shaft 1 pivots, resulting in the spline-like connection 14, 15 causing the shift finger 4 to pivot and act upon the undepicted

engagement shaft. The pivoting movement causes the ball of the indexing mechanism 7 of the shift finger 4 to be pushed outwards and to slide in the peripheral direction on the rotary shaft 1.

In the example depicted, the rotary shaft has only one hollow 18 for the ball lock. Alternatively, the number of hollows may be the same as the number of shift fingers so that in a neutral state each ball 16 is pushed into a respective hollow. The hollow or hollows 18 may alternatively take the form of a groove of circular profile which runs in a circumferential direction.

Another example of an operating device according to the invention is illustrated in Figs. 4-7. In this case a rotary shaft package 101 is adapted to operating the shift fingers 102, 103, 104. The rotary shaft package 101 is composed of three coaxial rotary shafts 101a, 101b, 101c each connected to, for joint rotation with, the respective one of the shift fingers 102, 103, 104. The two outer rotary shafts 101b, 101c are therefore hollow shafts, while the inner rotary shaft 101a may alternatively be solid.

The rotary shafts are each provided at their left end in the diagram with respective radially protruding pins 105, 106, 107 which in a neutral state are all in the same axial plane. The inner driveshaft 101a extends somewhat further out to the left than the middle driveshaft 101b, which itself extends somewhat further out than the outermost driveshaft 101c. The purpose of this is to provide space for the pins 105, 106 on the two inner shafts. A slide 110 for effecting the pivoting movement of the rotary shafts is provided in the region of their pins. The rotary shaft package 101 is journalled at its right end in the diagram in a bearing housing 108 supported by a bearing bracket 109 in a similar way to the first example.

The slide 110 is of generally cylindrical shape with an inside diameter corresponding to the outside diameter of the outer rotary shaft 101c and is journalled on the latter in such a way that it can be moved axially and pivoted. An opening 111 running axially extends along the whole length of the slide 110.

The opening is of varying width and divided into three sections 111a, 111b, 111c each running one-third of the length of the slide 110. A section 111a of relatively large width corresponding to an angle of barely half a turn is situated at one end of the slide 110. A further section 111c of the same width is situated at the other end of the slide 110. There is between them, in the axial central region of the slide, a section 111b of considerably smaller width than the first and second

sections. The width of the middle section 111b corresponds to an angle of about 10°.

The middle section takes the form of a tongue 115 extending out from each side of the edges of the opening which constitute the wider sections 111a, 111c. The third section 111b is situated symmetrically relative to the other two.

Engaging and disengaging a gear is effected by moving the slide 110 axially along the rotary shaft package 101 so that the section 111b with the smallest width becomes axially central to whichever of the pins 105, 106, 107 is associated with the gear which is to be engaged. Thereafter the slide 110 is pivoted, whereupon one edge of the smallest-width section 111b is pressed against the respective pin, which in the diagram is the middle pin 106, and causes it to pivot with it. The result is pivoting of the rotary shaft 101b to which the pin 106 is fastened and hence of the shift finger 103 fastened to the rotary shaft. The shift finger 103 then moves in a conventional way the associated engagement shaft (not depicted).

When the slide 110 pivots to manoeuvre the pin 106, the other two pins 105, 107 will not be affected, since the sections 111a, 111c of the opening which are situated axially to them are of considerably greater width. The respective edges of these sections will not reach the respective pin during the pivoting movement, since the angular distance between an edge of the smallest-width section 111b and the corresponding edges of the other two sections 111a, 111c is greater than the required movement angle.

It may be appreciated that the smallest-width section need not necessarily be situated axially at the middle of the slide. It may alternatively be at one end of the slide, in which case the other two sections will form a composite larger-width section.

Ref. 112 symbolises a control means for the axial movement of the slide 110, and ref. 113 a control means for the slide's pivoting via one of the pivot lugs 114 provided on the slide. Although these control means may themselves comprise conventional pneumatics or hydraulics, the operating device according to the invention makes it possible to use for this purpose simpler and less expensive means such as solenoids or electric motors. With advantage, the operating device is therefore of this kind.

Fig. 7 shows the respective rotary shafts 101a, 101b, 101c each extending to the respective associated operating fingers 102, 103, 104, to which they are connected for joint rotation with them. The diagram also shows the slide 110 placed on the outside of the shaft package at the latter's left end in the diagram.

5 Fig. 8 illustrates schematically a gearbox 202 provided with an operating device 200 according to the invention, whereby the gear change movement is transmitted in a conventional way via an engagement element 201 with engagement shaft 203 and switching yoke 204.

10 Fig. 9 illustrates a vehicle 205 provided with a gearbox 202 according to the invention.

CLAIMS

1. An operating device for an automatically switched manual gearbox, which gearbox is provided with a movable engagement element for each gear, which operating device is provided with rotary shafts (1, 101a, 101b, 101c) and rotatable shift finger means (2, 3, 4, 102, 103, 104) to move selected engagement elements, each shift finger means (2, 3, 4, 102, 103, 104) comprising a number of separate shift fingers (2, 3, 4, 102, 103, 104) each associated with a specific engagement element and separately pivotable independently of the other shift fingers, the shift fingers (2, 3, 4) being fitted axially after one another along a rotary shaft (1), **characterised** in that the rotary shaft (1) is movable axially to assume various operating positions, in each of which the rotary shaft (1) is connected to, for joint rotation with, at least one of the shift fingers (2, 3, 4) and is pivotable relative to the other shift fingers.
2. An operating device according to claim 1, **characterised** in that the rotary shaft (1) extends through a hole in each shift finger (2, 3, 4), each of which holes has at least one groove (15) running through it axially, and the rotary shaft (1) is provided with at least one radial protrusion (14) for pivoting cooperation with respective grooves (15) in at least one of the shift fingers (2, 3, 4) depending on the operating position of the rotary shaft (1).
3. An operating device according to claim 2, **characterised** in that each shift finger (2, 3, 4) is provided with an indexing element (16) urged towards the rotary shaft by a respective spring (17), and the rotary shaft (1) is provided with at least one hollow (18) adapted to being able to accommodate any of the indexing elements (16).
4. An operating device according to any one of claims 1-3, **characterised** in that the operating device comprises a solenoid or an electric motor adapted to turning the rotary shaft/one of the rotary shafts.
5. An automatically switched manual gearbox (202), **characterised** in that it is provided with an operating device (200) according to any one of claims 1-4.

6. A motor vehicle (205), **characterised** in that it is provided with a gearbox (202) according to claim 5.
7. An operating device for an automatically switched manual gearbox, which gearbox is provided with a movable engagement element for each gear, which operating device is provided with rotary shafts (1, 101a, 101b, 101c) and rotatable shift finger means (2, 3, 4, 102, 103, 104) to move selected engagement elements, each shift finger means (2, 3, 4, 102, 103, 104) comprising a number of separate shift fingers (2, 3, 4, 102, 103, 104) each associated with a specific engagement element and separately pivotable independently of the other shift fingers, **characterised** in that the shift fingers (102, 103, 104) are fitted axially after one another along a rotary shaft package (101) comprising a number of coaxial rotary shafts (101a, 101b, 101c) which are pivotable relative to one another and are each connected to, for joint rotation with, a specific shift finger (102, 103, 104).
8. An operating device according to claim 7, **characterised** in that each rotary shaft (101a, 101b, 101c) is provided with a radially protruding pivot element (105, 106, 107) connected to, for joint rotation with, the rotary shaft, which pivot elements are located axially after one another along the rotary shaft package (101).
9. An operating device according to claim 8, **characterised** in that the device comprises a slide (110) which is movable axially and rotatable on the rotary shaft package (101) and is provided with shoulder elements adapted to rotary action upon selected pivot elements (105, 106, 107) depending on the axial position of the slide (110).
10. An operating device according to claim 9, **characterised** in that the slide (110) takes the form of a cut cylinder journalled on the outermost of the rotary shafts and has an opening (111) running axially and comprising a first section (101b) with a smaller peripheral width and at least one second section (101a, 101c) with a larger peripheral width, said smaller and larger peripheral width being defined by the difference in angular extent being at least twice as great as the angular movement of a shift finger (102, 103, 104) required to engage or disengage a gear.

11. An operating device according to claim 10, **characterised** in that the opening (111) comprises two larger-width sections (101a, 101c) each situated axially on its respective side of the smaller-width section (101b).
- 5 12. An operating device according to claim 10 or 11, **characterised** in that the smaller width corresponds to an angle within the range 5-10° and the larger width to an angle within the range 120-175°.
13. An operating device according to any one of the claims 7-12, **characterised** in that the operating device comprises a solenoid or an electric motor adapted to turning a rotary shaft/one of the rotary shafts.
- 10 14. An automatically switched manual gearbox (202), **characterised** in that it is provided with an operating device (200) according to any one of claims 7-13.
- 15 15. A motor vehicle (205), **characterised** in that it is provided with a gearbox (202) according to claim 14.

1/5

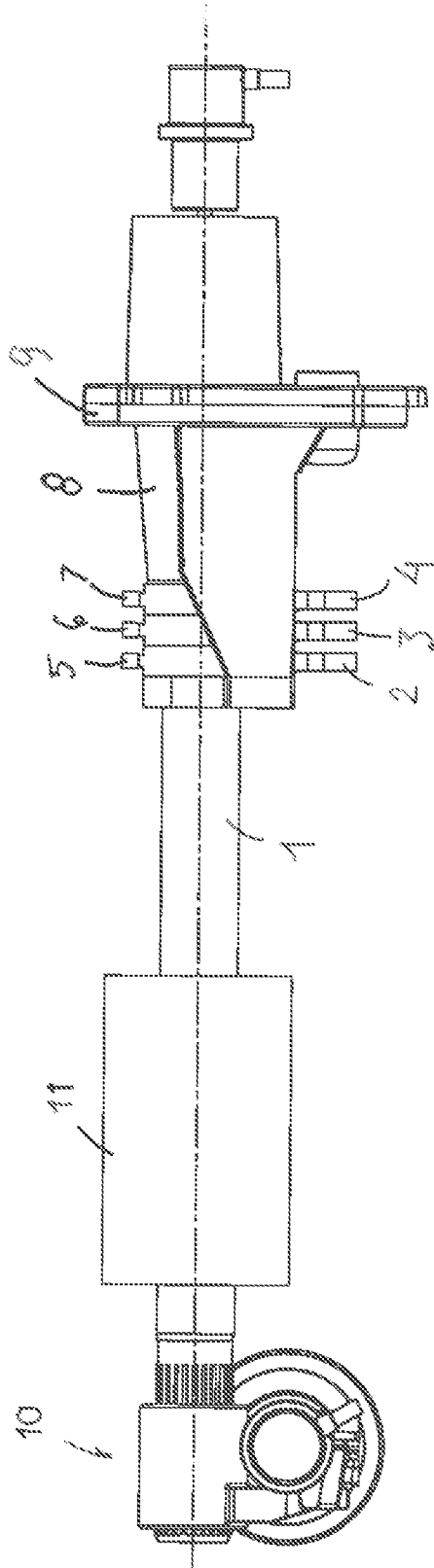

Fig. 1

2/5

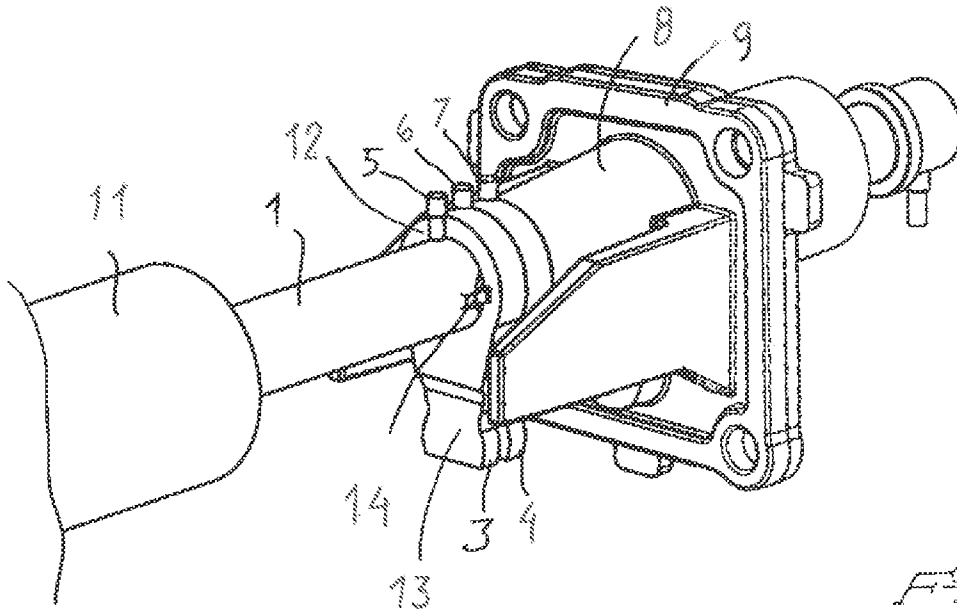

Fig. 2

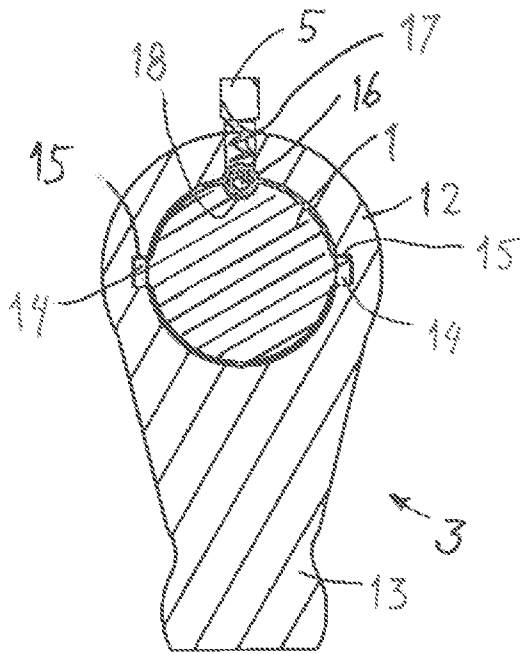
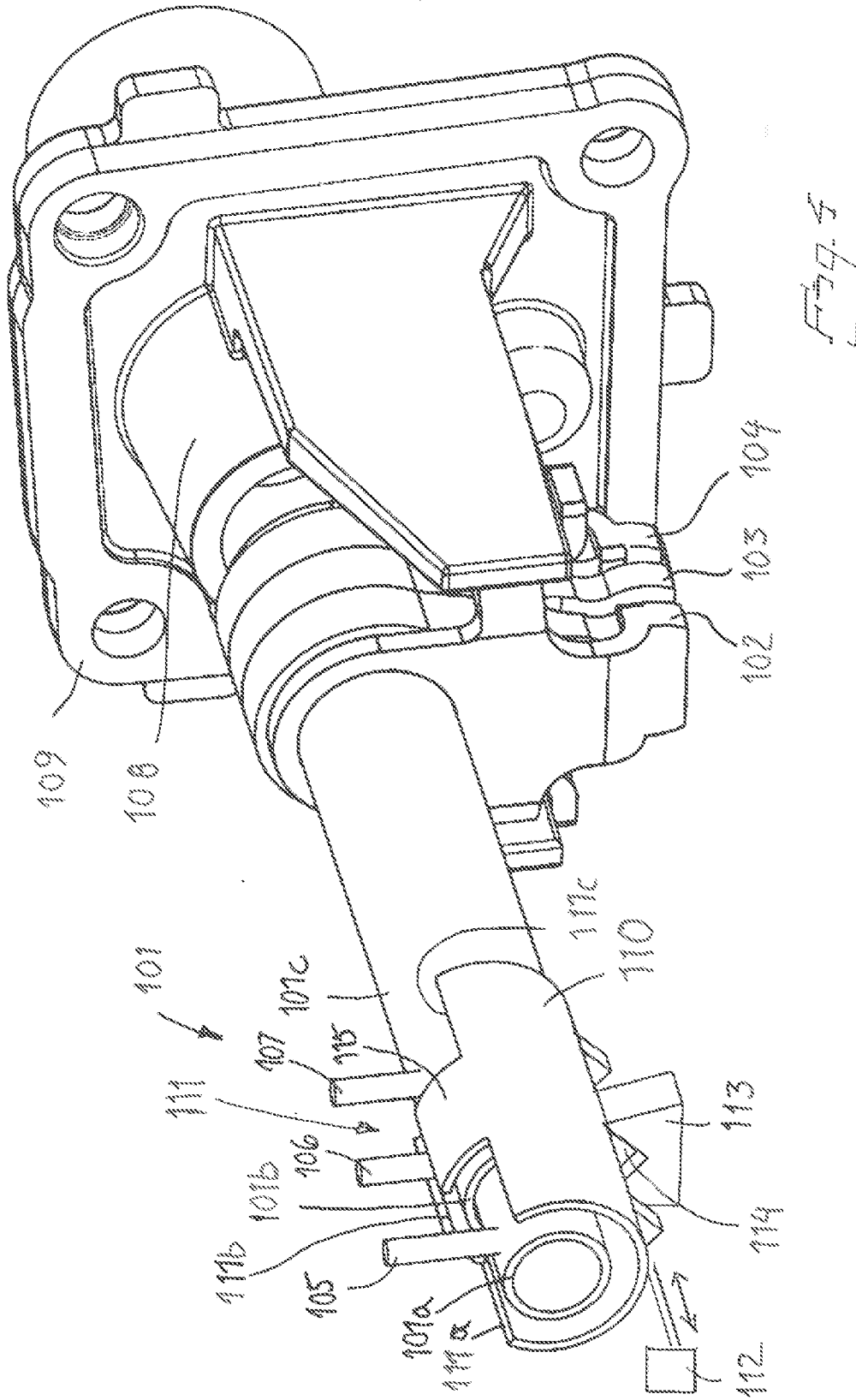

Fig. 3

3/5



4/5

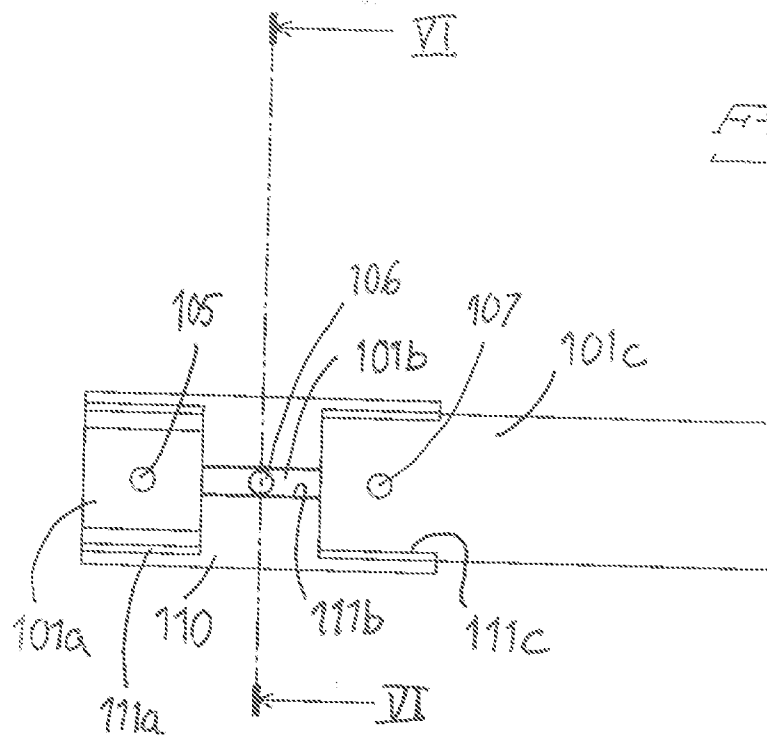

Fig. 5

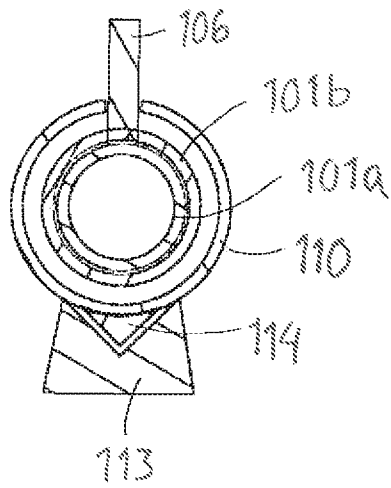

Fig. 6

5/5

Fig. 7

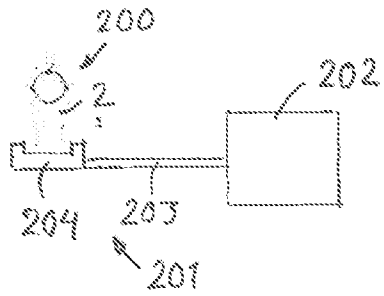
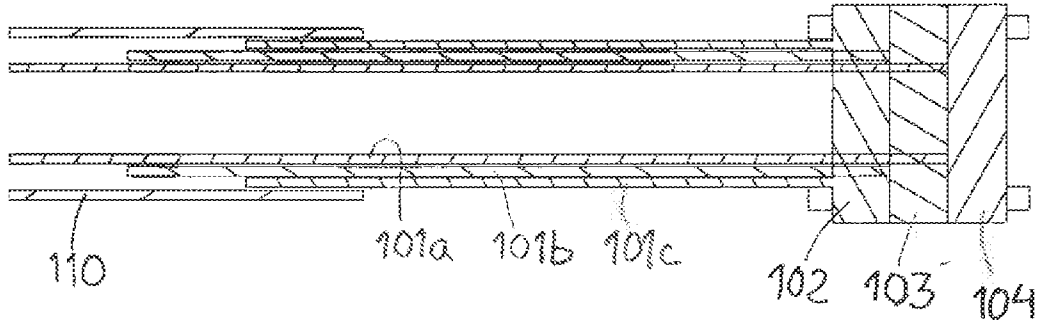

Fig. 8

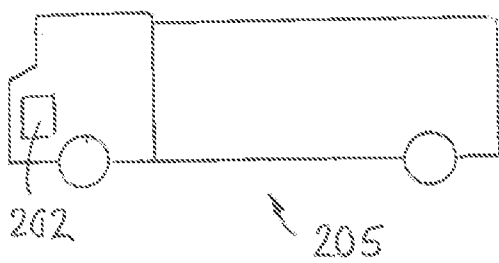

Fig. 9

INTERNATIONAL SEARCH REPORT

International application No.

PCT/SE2010/050664

A. CLASSIFICATION OF SUBJECT MATTER

IPC: see extra sheet

According to International Patent Classification (IPC) or to both national classification and IPC

B. FIELDS SEARCHED

Minimum documentation searched (classification system followed by classification symbols)

IPC: F16H

Documentation searched other than minimum documentation to the extent that such documents are included in the fields searched

SE,DK,FI,NO classes as above

Electronic data base consulted during the international search (name of data base and, where practicable, search terms used)

EPO-INTERNAL, WPI DATA, PAJ

C. DOCUMENTS CONSIDERED TO BE RELEVANT

Category*	Citation of document, with indication, where appropriate, of the relevant passages	Relevant to claim No.
A	DE 102006017265 A1 (AKTIEBOLAGET SKF), 19 October 2006 (19.10.2006), figures 1-7, abstract, paragraphs (0018)-(0021) --	1-15
A	US 20040154419 A1 (HARRIES ET AL), 12 August 2004 (12.08.2004), figures 2-6, abstract --	1-15
A	FR 2860567 A1 (RENAULT S.A.S.), 8 April 2005 (08.04.2005), figures 1,2, abstract --	1-15
A	US 20060150761 A1 (BEER ET AL), 13 July 2006 (13.07.2006), figure 4, abstract --	1-15

 Further documents are listed in the continuation of Box C. See patent family annex.

* Special categories of cited documents:

"A" document defining the general state of the art which is not considered to be of particular relevance

"E" earlier application or patent but published on or after the international filing date

"L" document which may throw doubts on priority claim(s) or which is cited to establish the publication date of another citation or other special reason (as specified)

"O" document referring to an oral disclosure, use, exhibition or other means

"P" document published prior to the international filing date but later than the priority date claimed

"T" later document published after the international filing date or priority date and not in conflict with the application but cited to understand the principle or theory underlying the invention

"X" document of particular relevance: the claimed invention cannot be considered novel or cannot be considered to involve an inventive step when the document is taken alone

"Y" document of particular relevance: the claimed invention cannot be considered to involve an inventive step when the document is combined with one or more other such documents, such combination being obvious to a person skilled in the art

"&" document member of the same patent family

Date of the actual completion of the international search

20 August 2010

Date of mailing of the international search report

26-08-2010

Name and mailing address of the ISA/

Swedish Patent Office

Box 5055, S-102 42 STOCKHOLM

Facsimile No. +46 8 666 02 86

Authorized officer

Jan-Axel Ylivainio / JA A

Telephone No. +46 8 782 25 00

INTERNATIONAL SEARCH REPORT

International application No.

PCT/SE2010/050664

C (Continuation). DOCUMENTS CONSIDERED TO BE RELEVANT

Category*	Citation of document, with indication, where appropriate, of the relevant passages	Relevant to claim No.
A	DE 102005058406 A1 (H.C.F. PORSCHE AG), 14 June 2007 (14.06.2007), figures 1,2, abstract --	1-15
A	DE 10108881 A1 (VOLKSWAGEN AG), 5 Sept 2002 (05.09.2002), figures 3,4, abstract --	1-15
A	US 20090038423 A1 (SHINTANI), 12 February 2009 (12.02.2009), figures 2,3, abstract --	1-15
A	FR 2863028 A1 (PEUGEOT CITROEN AUTOMOBILES SA), 3 June 2005 (03.06.2005), figures 1-5, abstract -- -----	1-15

International patent classification (IPC)**F16H 63/20** (2006.01)**F16H 61/32** (2006.01)**Download your patent documents at www.prv.se**

The cited patent documents can be downloaded:

- From "Cited documents" found under our online services at www.prv.se (English version)
- From "Anförda dokument" found under "e-tjänster" at www.prv.se (Swedish version)

Use the application number as username. The password is **OGOTCNDYTI**.

Paper copies can be ordered at a cost of 50 SEK per copy from PRV InterPat (telephone number 08-782 28 85).

Cited literature, if any, will be enclosed in paper form.

INTERNATIONAL SEARCH REPORT
Information on patent family members

International application No.
PCT/SE2010/050664

DE	102006017265	A1	19/10/2006	FR	2884576 A	20/10/2006
				IT	T020050245 A	14/10/2006
US	20040154419	A1	12/08/2004	NONE		
FR	2860567	A1	08/04/2005	NONE		
US	20060150761	A1	13/07/2006	NONE		
DE	102005058406	A1	14/06/2007	NONE		
DE	10108881	A1	05/09/2002	NONE		
US	20090038423	A1	12/02/2009	NONE		
FR	2863028	A1	03/06/2005	NONE		