

(19) **DANMARK**

(10) **DK/EP 3482182 T4**



(12) **Oversættelse af ændret
europæisk patentskrift**

Patent- og
Varemærkestyrelsen

-
- (51) Int.Cl.: **G 01 M 5/00 (2006.01)** **F 03 D 17/00 (2016.01)** **F 03 D 1/06 (2006.01)**
- (45) Oversættelsen bekendtgjort den: **2025-03-03**
- (80) Dato for Den Europæiske Patentmyndigheds bekendtgørelse om opretholdelse af patentet i ændret form: **2025-02-19**
- (86) Europæisk ansøgning nr.: **17735522.9**
- (86) Europæisk indleveringsdag: **2017-07-05**
- (87) Den europæiske ansøgnings publiceringsdag: **2019-05-15**
- (86) International ansøgning nr.: **EP2017066764**
- (87) Internationalt publikationsnr.: **WO2018011034**
- (30) Prioritet: **2016-07-11 DE 102016112633**
- (84) Designerede stater: **AL AT BE BG CH CY CZ DE DK EE ES FI FR GB GR HR HU IE IS IT LI LT LU LV MC MK MT NL NO PL PT RO RS SE SI SK SM TR**
- (73) Patenthaver: **Wobben Properties GmbH, Borsigstrasse 26, 26607 Aurich, Tyskland**
- (72) Opfinder: **KUHNKE, Chris, Am Tiergarten 17, 26603 Aurich, Tyskland**
DIETZ, Dennis, Hartwigstraße 23a, 28209 Bremen, Tyskland
- (74) Fuldmægtig i Danmark: **Zacco Denmark A/S, Arne Jacobsens Allé 15, 2300 København S, Danmark**
- (54) Benævnelse: **Torsionsvinkelmåling af en rotorvinge**
- (56) Fremdragne publikationer:
WO-A1-03/029750
DE-A1-102007 007 047
GB-A- 2 479 923
GB-A- 2 487 072
US-A1- 2011 150 648
Awadi ET AL: "LA TORSION SIMPLE", , 13 July 2014 (2014-07-13), XP055671154, Retrieved from the Internet: URL:https://www.technologuepro.com/resistance-des-materiaux/chapitre-5-la-torsion-simple.pdf [retrieved on 2020-02-24]
DE-A1- 102007 007 047
AWADI ET AL: "LA TORSION SIMPLE", 13 July 2014 (2014-07-13), XP055671154, Retrieved from the Internet <URL:https://www.technologuepro.com/resistance-des-materiaux/chapitre-5-la-torsion-simple.pdf> [retrieved on 20200224]

Measuring a torsion angle of a rotor blade

5 The invention relates to a measuring system and to a method for determining a torsion of a rotor blade. The invention also relates to a corresponding rotor blade and to a method for arranging a measuring system according to the invention in the rotor blade and in addition to a corresponding wind power installation.

10 During the operation of a wind power installation, the rotor blades rotate about a substantially horizontal rotor axis. Because of aerodynamic effects that occur on the rotor blades during the rotation, the rotor blades can twist or undergo torsion. In this case, for example, the orientation of a profile chord in the region of the blade tip is at an angle with respect to the orientation of a profile chord in the region of the blade root. This angle is referred to here as the torsion angle and it depends on the positions of the profile chords
15 along the rotor blade.

At least one known method for determining the torsion angle is based on the use of a camera system. For this, a camera which is directed at the wind power installation is set
20 up in an area in front of the wind power installation. The camera detects the position of the rotor blades, for example by way of markings provided on the rotor blades, and from this can infer the orientation of the profile chords or a deformation of the rotor blade. Then, the torsion angle of the rotor blade can be determined from the orientation of the profile chords in relation to one another. A disadvantage of this system is that it can only
25 be used at restricted times, to be specific when the rotor has a specific orientation in relation to the camera. Furthermore, such a system also involves great preparational effort, or the operator of the wind power installation is dependent on external service providers.

Other known solutions for determining the torsion angle provide fiber-optic cables in the
30 rotor blade. The fiber-optic cable is in this case adhesively attached to the material of the rotor blade. The deformation or torsion of the rotor blade, and consequently the deformation or torsion of the cable, brings about the effect of a polarization of the light conducted through the fiber-optic cable. By means of an evaluation unit, the torsion angle can be inferred from the polarization. However, it has been found that with such a system
35 there is a great dependence on the bending behavior of the rotor blade, as a result of which erroneous torsion angles are determined when there is simultaneous bending and

torsion of the rotor blade. In addition, a cable adhesively attached to the rotor blade is influenced by the thermal expansion of the rotor blade. The measurement consequently does not take place temperature-independently.

- 5 The German Patent and Trademark Office has searched the following prior art in the priority application for the present PCT application: DE 10 2014 117 914 A1 and US 2013/0093 879 A1.

Another relevant prior art document is DE 10 2007 007047 A1.

10 The present invention is therefore based on the object of addressing at least one of the aforementioned problems. In particular, it is intended to propose a solution with which the torsion angle can be continuously detected and also or alternatively it is intended to propose a solution which determines the torsion angle independently of possible bending of the rotor blade. At least it is intended to propose an alternative solution to previous systems.

15 According to the invention, a measuring system for determining a torsion of a rotor blade according to claim 1, a method according to claim 7 and a rotor blade according to claim 9 are proposed.

20 Such a measuring system comprises a reference shaft to be arranged in the rotor blade and a number of rotary sensors arranged on the reference shaft. The reference shaft is supported in such a way that the rotor blade can twist freely about the reference shaft and in such a way that the reference shaft itself does not twist when there is twisting of the rotor blade. So if the rotor blade twists during operation, a differential angle occurs between the twisted rotor blade and the non-twisted reference shaft. The rotary sensors arranged on the reference shaft detect the torsion or the twisting of the rotor blade about
25 the reference shaft in the region of the rotary sensor and output a rotational angle describing the twisting of the rotor blade in relation to the reference shaft, or some other corresponding variable.

30 Instead of the rotational angle, an electrical voltage or a value normalized to a maximum rotational angle that is proportional to the rotational angle may for example be output as a corresponding variable.

Therefore, a measuring system in which the rotor blade twists about a rigid reference shaft is proposed. By comparison with the reference shaft, the twisting of the rotor blade

can in this way be quantitatively detected at each location of the rotor blade at which a rotary sensor is arranged.

5 With such a measuring system, the torsion angle can be continuously detected, since the rotary sensor continuously detects a torsion angle of the rotor blade in relation to the reference shaft. Such a measuring system is also independent of the alignment of the rotor with an external system, since the measuring system is integrated in the rotor blade.

10 According to the invention it is provided that the reference shaft is formed as a hollow shaft. Hollow shafts allow a lightweight construction and nevertheless have a great stiffness, in particular also a great torsional stiffness. If the reference shaft is formed as a hollow shaft, the measuring system only increases the weight of the rotor blade insignificantly. The measuring system consequently scarcely influences the properties of the rotor blade.

15 A further embodiment of the measuring system provides supporting means in order to arrange the reference shaft along a leading edge web of the rotor blade. The leading edge web of a rotor blade runs substantially over the entire length of the rotor blade in the region of the leading edge of the rotor blade. The leading edge web represents a connection in this front region between an upper side and an underside of the rotor blade and stiffens the rotor blade, in order that the rotor blade withstands the wind loads to which it is exposed. In particular, a rotor blade twists substantially about the leading edge web. The leading edge web is consequently very well suited for determining the torsion angle of the rotor blade, since the distance from the torsion axis, that is to say the axis about
20 which the rotor blade twists, is minimal here and no or only minor deviations occur. The leading edge web can extend substantially through the entire rotor blade, and is consequently very well suited for receiving the reference shaft and guiding it through the entire blade.

30 In a further embodiment of the measuring system, a rotationally fixed shaft seat is provided in order to fasten one end of the reference shaft in a rotationally fixed manner in the region of a rotor blade root or in the region of a rotor blade tip. A rotationally fixed fastening of an outer end of the reference shaft in the rotor blade tip has the effect that twisting in the region of the rotor blade tip is transmitted via the rotationally rigid reference
35 shaft to an inner end of the reference shaft. This inner end may for example be arranged at the rotor blade root or at an end of the leading edge web that is arranged in the vicinity of the rotor blade root. As a result, the twisting of the rotor blade tip can be measured at

the inner end of the reference shaft, that is to say for example in the region of the rotor blade hub.

5 Good installability of the measuring system is also provided, by the reference shaft being able for example to be pushed into the rotationally fixed shaft seat in the region of the blade tip, or the reference shaft together with the rotationally fixed shaft seat being able to be pushed into the rotor blade tip. The problem of a blade tip that is poorly accessible from the inside is at least reduced in this way. As a result, rotary sensors in the region of the poorly accessible rotor blade tip are also no longer necessary.

10 The rotor blade root consequently forms a fixed point for the reference shaft and for the twisting to be detected. The rotor blade itself twists from the blade root, since that is where the blade is fastened on a rotor hub. Consequently, a twisting is detected with reference to the blade root. The reference shaft forms a torsion-free extension of the blade root. The detection of a twisting in relation to the reference shaft is consequently a detection of the
15 twisting in relation to the blade root.

However, the reference shaft is supported by position bearings along its length in such a way that it is substantially only loosely kept in position, with only transverse forces being passed on by the position bearings. Torsional forces however are not introduced into the reference shaft. Consequently, at these position bearings, the rotor blade can twist freely
20 about the reference shaft. A twisting of the rotor blade tip with respect to the rotor blade root would bring about a rotational angle between the twisted rotor blade in the blade tip and the non-twisted reference shaft and would indicate a torsion angle at the blade tip.

Alternatively, it may be provided that the reference shaft is supported in a rotationally fixed manner in a region of the rotor blade root. A twisting of the rotor blade tip would then have
25 the effect that it twists in relation to the reference shaft. For detecting the twisting of the blade tip, it would however also be necessary for the rotary sensor to be arranged in the region of the poorly accessible blade tip.

Specifically at one end or some other location of the reference shaft, the latter must be connected to the rotor blade in a rotationally fixed manner. This may for example also be
30 in the middle. The measuring system can consequently be used for various types of rotor blades, for which there are different installation situations.

A development of the measuring system provides that the reference shaft is electrically non-conductive. This particularly achieves lightning protection, which prevents lightning from striking the reference shaft, or prevents a lightning strike from inducing a current in the reference shaft.

5 In one embodiment, the reference shaft is produced from a fiber composite material. A plastic reinforced with aramid fibers or carbon fibers is particularly envisaged for this. Such plastics have a high strength with at the same time low weight, and consequently allow a very lightweight reference shaft. In addition, such plastics have no or only a small positive or negative coefficient of thermal expansion, so that the reference shaft experiences little
10 thermal expansion over a very great temperature range. The measurement of the rotary sensors is consequently temperature-independent. As a result, mechanical stresses can particularly also be avoided.

In a further configuration of the measuring system, the reference shaft is supported in an axially displaceable manner. This can take place by means of the position bearings already
15 mentioned above. Consequently, expansions of the rotor blade on account of temperature changes or for other reasons do not influence the reference shaft. Such expansions of the rotor blade, which can also be caused by a bending of the rotor blade, only lead to a relative axial displacement between the rotor blade and the reference shaft.

A rotary sensor may particularly be formed by a marker element fastened on the reference
20 shaft and a pickup fastened alongside it on the rotor blade. A twisting of the rotor blade in the region of such a sensor then leads to a twisting of the marker element in relation to the pickup. The marker element may also be referred to as a transducer. The pickup can detect this relative twisting and determine and output the reference angle or a variable corresponding thereto. The marker element may for example be formed as an annular disk with
25 a barcode, or simply have a reference marking that allows a twisting to be detected. Depending on the characteristics of the reference shaft and the requirement for accuracy, the marker element may also be no longer necessary and the pickup may detect a relative movement of the reference shaft directly.

With such a rotary sensor, the position of the two portions in relation to one another, that is
30 to say the torsion angle, can be detected very accurately. Purely bending of the reference shaft does not in this case influence the rotational angular position of the two portions in relation to one another. Also, a slight displacement along the torsion axis, for example due to thermal expansion, does not influence the rotational angular position of the two portions

in relation to one another. Only a torsion of the rotor blade causes a twisting of the two portions in relation to one another, from which the torsion angle of the rotor blade can be determined. The torsion angle determination is consequently independent of other influences.

5 According to the invention, a number of rotary sensors for detecting a twisting of the rotor blade are arranged at a number of positions along the reference shaft. This allows the torsion angle to be determined at a number of positions along the radius of the rotor. A number of rotary sensors along the reference shaft make it possible to detect regions of the rotor blade that twist more than other regions. A greater torsion may occur because of
10 a lower stiffness of the rotor blade, for example in the blade tip. Any overloading of individual regions of the rotor blade can in this way also be detected.

A further embodiment of the measuring system is characterized in that the reference shaft is supported on the number of rotary sensors along the longitudinal direction of the blade, so that the rotor blade can rotate about the reference shaft. The rotary sensors therefore
15 form at the same time the support for the reference shaft along the longitudinal direction of the rotor blade. This may particularly concern a rotor sensor that has a marker element and a pickup, the reference shaft being supported in the pickup of the rotary sensor. Consequently, additional bearings, and therefore additional weight and/or additional costs, can be avoided. However, the rotary sensors are intended at the same time to allow a free
20 rotation of the rotor blade about the reference shaft. In a further configuration of the measuring system, the supporting means are adhesively attached or clamped to the leading edge web. For the adhesive attachment, each supporting means may particularly have a flat adhering surface, which is provided with an adhesive, or can be provided with an adhesive. As a result, simple and robust fastening is possible. Clamping of the supporting
25 means is envisaged in particular in those regions of the rotor blade that are not accessible or poorly accessible for the mounting of the measuring system. For this, the supporting means can for example be pushed onto the web and are adapted to a geometry of the leading edge web onto which they are pushed. By means of an auxiliary means, the supporting means is then brought into the inaccessible region and clamped at the intended
30 position. In this way, retrofitting of the measuring system in rotor blades that are already in use is possible. The supporting means for arranging the reference shaft on the leading edge web can be adhesively attached at locations that are accessible in the rotor blade. A further advantageous configuration of the measuring system envisages that at least one of the rotary sensors is formed as an optical rotary sensor. Particularly, an optical scanning

of the marker element by the pickup is proposed. Furthermore, it also comes into consideration that one of the rotary sensors operates exclusively optically and detected values or positions of a torsion angle are also transmitted optically, particularly via optical waveguides, to an evaluation unit, which may be arranged in the blade root or the rotor hub. By
5 the use of such optical rotary sensors, protection from or immunity to a lightning strike can likewise be achieved.

Another configuration of the measuring system is characterized in that the reference shaft is formed by a number of shaft segments. Such a configuration is very advantageous for installing or retrofitting the measuring system in very long rotor blades, which may have a
10 length of over 60 meters, since it allows the shaft to be transported to the installation site in a number of individual parts and put together to the intended length on site. The shaft segments may for example have ends that are adapted to one another in order to be inserted into one another. In this case, the adapted ends are formed in such a way that a rotationally rigid plug-in connection is produced when they are inserted into one another.

15 In addition, the present invention proposes a method for determining a torsion of a rotor blade according to claim 7. It operates in such a way that a torsion of the rotor blade about a reference shaft arranged in the rotor blade in the longitudinal direction of the blade is detected, the reference shaft is supported in the rotor blade in such a way that the rotor blade can twist freely about the reference shaft, so that the reference shaft does not twist
20 when there is twisting of the rotor blade, a twisting is detected by rotary sensors arranged on the reference shaft for detecting a twisting of the rotor blade about the reference shaft in the region of the rotary sensor, and a rotary angle describing the twisting of the rotor blade in relation to the reference shaft, or some other corresponding variable, is output by means of the rotary sensor.

25 With particular preference, the method uses a measuring system according to an embodiment described above. Furthermore or alternatively, the method operates as described above in conjunction with at least one embodiment of a measuring system.

According to the invention the rotational angle or the twisting of the rotor blade is detected at a number of positions distributed in the longitudinal direction of the blade. Consequently,
30 the torsion angle can be determined at a number of positions of the rotor blade and this can be used to obtain information about the torsion behavior in different regions of the rotor blade.

A further embodiment of the method provides that the rotational angle and/or the twisting of the rotor blade is detected continuously over time. For example, for this, data of the rotary sensors are recorded and, particularly, further processed by a process computer. Consequently, the torsion angle can likewise be determined continuously over time and used for
5 controlling the operational control of the wind power installation. The rotational angle thus detected or the twisting thus detected of the rotor blade can be fed to a control system of the wind power installation for further processing.

Furthermore, the present invention proposes a rotor blade of a wind power installation according to claim 9. The rotor blade comprises a rotor blade root for fastening the rotor blade
10 on a rotor hub, a rotor blade tip arranged on a side of the rotor blade that is facing away from the rotor blade root, a reference shaft arranged in the rotor blade in the longitudinal direction of the blade, at least one support for the reference shaft, for freely bearing the reference shaft in the rotor blade, so that the rotor blade can twist freely about the reference shaft, so that the reference shaft does not twist when there is twisting of the rotor blade,
15 and a number of rotary sensors arranged on the reference shaft for detecting a twisting of the rotor blade about the reference shaft in the region of the rotary sensor, the rotary sensor outputting a rotational angle describing the twisting of the rotor blade in relation to the reference shaft, or some other corresponding variable.

20 Such a rotor shaft particularly comprises a measuring system as described above according to at least one embodiment. This allows a torsion of the rotor blade to be detected in an easy way, in particular as already described above.

Such a rotor blade makes accurate determination of a torsion angle of the rotor blade possible.
25 This allows conclusions to be drawn about the output and the operating state of the wind power installation. In particular, aerodynamic assumptions and simulations of the structural design of the rotor blade can also be validated, in particular with regard to the influence of the torsion angle on operating loads, the output or the noise generated.

Preferably, at least one leading edge web running from the rotor blade root in the direction
30 of the rotor blade tip is provided, the reference shaft and at least one portion of a rotary sensor being arranged on the leading edge web. As a result, the measuring system can be formed in the rotor blade in an easy way, because the leading edge web runs substantially from the blade root to the blade tip, and consequently offers a good possibility for fastening or supporting the measuring system in the rotor blade. According to a further embodiment,
35 it is proposed that the supporting of the reference shaft takes place between two webs,

particularly between two webs that do not comprise the leading edge web, and takes place there on one of these webs. As a result, the measuring system can be mounted in the rotor blade during the production of the rotor blade, when mold halves of the rotor blade are still open. This also allows supporting of the reference shaft at the end on the blade tip side to
5 be made easier.

One embodiment of the rotor blade provides that the rotor blade has in its blade tip a shaft seat for bearing the reference shaft in a rotationally fixed manner. Such a shaft seat in the rotor blade has the advantage that no additional means are necessary for fastening the reference shaft on the rotor blade in a rotationally fixed manner. A rotationally fixed support
10 for the reference shaft is necessary, since a rotational angle of the rotor blade with respect to the reference shaft is to be detected.

A further embodiment of the rotor blade is characterized in that the reference shaft is clamped in a structural element of the rotor blade, particularly in an inner contour of the leading edge web, in a rotationally rigid manner by means of a fitting piece. As a result,
15 rotationally rigid fastening can be achieved even in the poorly accessible rotor blade tip.

A leading edge web is particularly suitable for this. Such a leading edge web has an upper flange and a lower flange, which are arranged lying opposite one another and are connected by way of a middle web portion. This provides a region in addition to the middle web portion and the two flanges into which the fitting piece can be clamped. There is in this case
20 a good and durable fastening particularly where an undercut region is obtained between the flanges, to be specific particularly as a result of the two flanges not running exactly plane-parallel. In this way, supporting means can also be fastened on the leading edge web. With the supporting means, it should particularly be noted that they do not have to take much weight with the reference shaft.

25 Particularly in inaccessible regions of the rotor shaft, the supporting means can be easily pushed to the intended position and clamped there, so that no additional means are necessary for arranging the supporting means, and as a result the reference shaft, on the leading edge web or some other structural part of the rotor blade.

A preferred alternative embodiment of the rotor blade is characterized in that the rotor blade
30 has in its blade root a shaft seat for bearing the reference shaft in a rotationally fixed manner. The reference shaft can be supported in the blade root in a particularly securely rotationally fixed manner and such a support can also be inspected quite well. In the case of

this embodiment, the reference shaft remains at rest and the rotor blade twists about the reference shaft. As a result, unlike in the case of fixing in the blade tip, the reference shaft is not turned about its own axis when there is torsion of the rotor blade.

A wind power installation with a rotor blade according to the invention is also proposed.

- 5 Finally, the present invention also proposes a method for mounting a measuring system according to one of the embodiments or configurations described above in a rotor blade of a wind power installation.

The method comprises the steps of fastening a fitting piece in a rotationally rigid manner on a blade tip portion of the reference shaft, pushing the reference shaft with the fitting
10 piece out in front into an installation space in the blade tip of the rotor blade, along a structural element, particularly a leading edge web, pushing the supporting means onto the reference shaft and fastening the supporting means along the structural element or the leading edge web, arranging a number of rotary sensors in the region of the reference shaft in the rotor blade. Here, the special nature of the rotationally rigid reference shaft is particu-
15 larly used for the mounting, in that this reference shaft is pushed from a region of the rotor blade that can be reached by a person into the space in the vicinity of the blade tip that cannot be reached by a person, and is consequently difficult to access. At the same time, the existing structure of the rotor blade is used there for the fastening.

Preferably, some of the supporting means are fastened in a region that cannot be reached
20 by a person in the vicinity of the blade tip by securely clamping on the structural element or in the leading edge web and some other of the supporting means are adhesively attached in a region that can be reached by a person on the structural element or the leading edge web. Also in this way, the existing situation in the rotor blade can be used. Particularly in the region that cannot be reached by a person, the leading edge web has a region that
25 tapers toward the blade tip and is often undercut, which can be used for pushing some supporting means in there in such a way that they are clamped there. All that is needed for this is for the respective supporting means to be adapted to the known size and shape of the region in which the supporting means is to be fixed. In the region that can be reached by a person, in which the leading edge web is also greater, fastening can be performed by
30 adhesive attachment. There is also sufficient space there for the adhesive attachment to be carried out properly.

The method also makes it possible for already existing wind power installations to be refitted with a measuring system according to the invention. In addition, such a measuring system can consequently also be repaired or refitted after a repair.

Also proposed according to the invention is a method according to claim 14 for maintaining or repairing a measuring system arranged in a rotor blade for determining a torsion of the rotor blade, and the measuring system comprises

- a reference shaft (12), arranged in the rotor blade in the longitudinal direction of the blade,
- at least one support for the reference shaft (12), for freely bearing the reference shaft (12) in the rotor blade, so that the rotor blade can twist freely about the reference shaft (12), so that the reference shaft (12) does not twist when there is twisting of the rotor blade, and
- a number of rotary sensors (20), arranged on the reference shaft, for detecting a twisting of the rotor blade about the reference shaft (12) in the region of the rotary sensor (20), the rotary sensor (20) outputting a rotational angle describing the twisting of the rotor blade in relation to the rotor shaft (12), or some other corresponding variable, comprising the steps of:
 - removing the rotor shaft or part of it from at least one of the supports,
 - taking out this at least one support and/or the at least one rotary sensor,
 - inspecting the support taken out or the rotary sensor taken out and
 - refitting the support or the rotary sensor, or a corresponding replacement part,
 - refitting the reference shaft or the part of it that was removed.

This allows maintenance or repair of the measuring system to be carried out in an easy way. By performing the successive steps, the elements can be individually removed and inspected and if need be repaired or replaced.

The invention is described by way of example below on the basis of embodiments with reference to the accompanying figures.

Fig. 1 perspectively shows a wind power installation in a schematic representation.

Fig. 2 shows a schematic representation of an embodiment of a measuring system according to the invention.

Fig. 3 schematically shows a supporting means given by way of example.

Fig. 4 schematically shows a supporting means arranged in a rotor blade.

Fig. 5 shows a leading edge web in a perspective representation.

Fig. 6 shows an enlarged detail of a leading edge web from Fig. 5.

Fig. 7 shows a further embodiment of a bearing means.

5 Fig. 1 shows a wind power installation 100 according to the invention with a tower 102 and a nacelle 104. Arranged on the nacelle 104 is a rotor 106 with three rotor blades 108 according to the invention and a spinner 110. During operation, the rotor 106 is set in a rotary motion by the wind, and thereby drives a generator in the nacelle 104. During the rotation, the rotor blades 108 may twist. For detecting and determining the torsion of the rotor blades
10 108, a measuring system is mounted in the rotor blades 108.

In Fig. 2, the components of the measuring system 10 are schematically represented. The measuring system 10 comprises a reference shaft 12. The reference shaft 12 is arranged in a rotor blade, on a leading edge web 13. The reference shaft 12 is preferably formed as a hollow shaft, so that a low weight is achieved, with at the same time a great stiffness of
15 the reference shaft 12. The reference shaft 12 has an outer diameter of approximately 25 millimeters and an inner diameter of approximately 21 millimeters.

For a better overview, only three schematic profile sections 14, 15, 16 of the rotor blade are shown, the profile section 14 schematically representing a profile section in the region of a rotor blade root, the profile section 15 schematically representing a profile section in a region of the middle of the rotor blade and the profile section 16 schematically representing
20 a profile section in a region of the rotor blade tip. For the sake of better overall clarity, particularly the profile 16, which is intended to represent such a profile in the vicinity of the blade tip, is shown enlarged. Also respectively indicated in the profile sections 14, 15, 16 by a dashed line is a profile chord, in order to represent a twisting of the profile section 16
25 with respect to the profile section 15 and the profile section 14. The profile section 15 is also twisted with respect to the profile section 14. The rotor blade is consequently twisted.

At one end, the reference shaft 12 is clamped in a shaft seat 18 in a rotationally fixed manner. The shaft seat 18 prevents a rotational movement of the reference shaft 12 about its longitudinal axis. In the exemplary embodiment shown, the reference shaft 12 is
30 clamped in the region of the rotor blade root in a rotationally fixed manner. Provided along

the reference shaft 12 are further bearings, which fasten the reference shaft 12 on the leading edge web 13. The further bearings are formed by supporting means 22 (see Fig. 3), which guide the reference shaft 12 but do not secure it in a rotationally rigid manner. Consequently, the rotor blade can twist about the reference shaft 12, without the reference shaft 12 twisting when there is twisting of the rotor blade.

Arranged along the reference shaft 12 are a number of rotary sensors 20. The rotary sensors 20 are merely represented schematically. The rotary sensors 20 may be fastened with a marker element on the reference shaft 12 and with a pickup on the leading edge web 13.

Fig. 2 also illustrates that the profile sections 14, 15, 16 are twisted to different degrees. With a number of rotary sensors 20 arranged along the reference shaft 12, consequently regions of the rotor blade with torsion angles of different magnitudes can also be determined.

Fig. 3 shows a schematic view of a supporting means 22. Such a supporting means 22 serves for arranging, guiding and bearing the reference shaft 22 on the leading edge web 13 or some other structural element of the rotor blade. The supporting means 22 are formed substantially as a tube. An inner diameter 24 of a preferred supporting means 22 is approximately 30 millimeters, and is consequently approximately 5 millimeters greater than the outer diameter of the preferred reference shaft 12. As a result, a free rotation of the rotor blade about the reference shaft 12 is possible with little to no friction. An outer diameter 26 of a preferred supporting means 22 is approximately 35 millimeters. A length 28 of a preferred supporting means 22 is approximately 250 millimeters.

Fig. 4 shows a supporting means 22, which is arranged on a leading edge web 13. The leading edge web 13 has an upper flange 30 and a lower flange 32. The supporting means 22 is clamped between the upper flange 30 and the lower flange 32 in order to arrange the reference shaft 12 on the leading edge web 13. To prevent a great flexural deflection of the reference shaft 12, supporting means 22 are provided approximately at a spacing of 2000 to 2500 millimeters along the leading edge web 13 for bearing the reference shaft 12.

Fig. 5 shows a leading edge web 13 in a perspective representation from a blade root region 51 to a blade tip region 52. An upper flange 30 and a lower flange 32 particularly form only toward the blade tip region 52.

Fig. 6 shows an enlarged detail of the blade tip region 52 of the leading edge web 13 from Fig. 5. It can be seen there that a fitting piece 60 is clamped between the upper and lower flanges 30, 32 and receives the reference shaft 12 in a rotationally rigid manner. To this extent, this represents a different embodiment in comparison with Fig. 2. The fitting piece
5 60 therefore forms a shaft seat for the reference shaft 12. The fitting piece 60 is quite similar in its construction to the supporting means 22 from Fig. 4, the reference shaft 12 not reaching through the fitting piece 60 and being received in a rotationally rigid manner.

Fig. 7 shows a further embodiment of a supporting means 22. In this case, additionally arranged on the reference shaft 12 are clamping parts 70, which can absorb tensile and
10 shearing forces of the reference shaft 12, which is formed as a hollow shaft. The clamping parts 70 are intended to prevent the reference shaft 12 from slipping out. The clamping parts should as far as possible be installed in such a way that contact of the clamping parts 70 with the support is avoided. In order in the event that contact does in fact occur to keep the friction as little as possible, it is proposed to provide a ball-bearing support between the
15 clamping part 70 and the supporting means 22, in order in this way to avoid a torsion of the reference shaft.

Otherwise, for simplicity, the same reference signs may be used for the embodiments shown for elements that are similar but not necessarily identical.

For mounting the measuring system 10, the reference shaft 12 is pushed in the direction of
20 the blade tip on the leading edge web 13. For this, the reference shaft 12 is preferably formed by a number of segments, which are individually connected to one another one after the other. At the end of the reference shaft 12 that is arranged in the region of the blade tip, the fitting piece 60 is fixedly mounted. The fastening element 22 is pushed in along the leading edge web until it is clamped between the upper flange 30 and the lower
25 flange 32. The fastening element 22 is therefore fastened on the leading edge web 13 in an interlocking and frictionally engaging manner. In the case of this embodiment, the reference shaft 12 is therefore mounted in the region of the blade tip in a rotationally fixed manner.

Alternatively, it is however provided that, with a rotationally fixed support for the reference
30 shaft 12 in the blade root, the fitting piece 60 only provides a final supporting of the reference shaft 12 in the blade tip, but allows a relative turning of the reference shaft. In this case, the fitting piece 60 is formed in such a way that the fitting piece 60 turns about the reference shaft 12 when there is torsion of the rotor blade.

Once the reference shaft 12 is mounted, the further supporting means 22 for bearing the reference shaft 12 are pushed on one after the other and, with the aid of an auxiliary tube, are brought to the prescribed setpoint position and pushed firmly into place. Clamping of the supporting means 22 takes place in regions of the rotor blade that are not accessible.

5 In accessible regions, the supporting means 22 are adhesively attached. On the last segment of the reference shaft 12, a supporting element 22 as shown in Fig. 7 for absorbing the tensile forces and shearing forces of the reference shaft 12 may be provided or adhesively attached.

At prescribed positions, a corresponding rotary sensor 20 is respectively provided.

10 The fixed restraint of the reference shaft 12 at one end of the leading edge web 13 has the effect that the torsion angles that are obtained along the radius of the rotor blade during the operation of the wind power installation are transmitted directly to the rotary sensors 20 along the leading edge web. Such a measuring system is unsusceptible to simultaneous occurrence of torsion and bending of the rotor blade, since exclusively twisting is detected

15 by the rotary sensors 20. Since the supporting means 22 do not clamp the reference shaft in a fixed manner, the measuring system is also unsusceptible to different thermal expansions of the rotor blade and the reference shaft 12. Since the system is permanently integrated in the rotor blade, the torsion angle can be determined at any point in time during the operation of the wind power installation. Consequently, operating states of the installation

20 can be monitored and simulation models that were used for designing the rotor blade and/or the wind power installation can be subsequently checked and thereby improved. As a result, the torsion angle can be used for controlling the operational control of the wind power installation.

It is also advantageous that, from the knowledge of the torsion angle, an operating state of

25 the wind power installation can be derived, which is proposed according to one embodiment according to the invention. In addition, with the aid of the torsion angle, control of the wind power installation can be optimized with regard to operating loads. The torsion angle may also serve as a reference for the output delivered by the wind power installation and the noise emitted by the rotor blades.

Patentkrav

5 **1.** Målesystem (10) til bestemmelse af en torsion af en rotorvinge, omfattende
- en referenceaksel (12), der skal anbringes i rotorvingen i vingens langsgående retning,

- mindst en lejrning af referenceakslen (12) til fri lejrning af referenceakslen (12) i rotorvingen, således at rotorvingen kan vrides frit omkring referenceakslen (12), således at referenceakslen (12) ikke vrides ved vridning af rotorvingen,

10 - mindst en drejesensor (20), der er anbragt på referenceakslen, til registrering af en drejning af rotorvingen omkring referenceakslen (12) i drejesensorens (20) område, hvor drejesensoren (20) afgiver en drejevinkel, der beskriver drejningen af rotorvingen i forhold til referenceakslen (12), eller en anden tilsvarende størrelse, **kendetegnet ved, at**

15 - referenceakslen (12) er udformet som hul akse,

- flere drejesensorer til registrering af en drejning af rotorvingen er anbragt i flere positioner langs referenceakslen.

2. Målesystem (10) ifølge krav 1,

kendetegnet ved, at

20 der er tilvejebragt lejringsmidler (22) for at anbringe referenceakslen (12) langs et forkantstykke (13) af rotorvingen, og/eller lejringsmidlerne (22) er forberedt til at fastklæbes eller fastklemmes på forkantstykket (13).

3. Målesystem (10) ifølge krav 1 eller 2,

25 **kendetegnet ved, at**

der er tilvejebragt en drejefast akseloptagelse (18) for at fastgøre en ende af referenceakslen (12) drejefast i området af en rotorvingespids, og/eller referenceakslen (12) er anbragt aksialt forskydeligt.

30 **4.** Målesystem (10) ifølge et af de foregående krav,

kendetegnet ved, at

referenceakslen (12) er fremstillet elektrisk ikke-ledende og/eller af et fiberkompositmateriale, især af kunststof, der er forstærket med aramidfibre eller

kulstoffibre, hvor referenceakslen (12) især er sammensat af flere akselseg-
menter.

5. Målesystem (10) ifølge et af de foregående krav,

5

kendetegnet ved, at

drejesensoren (20) er udformet som optisk drejesensor og/eller omfatter et
markørelement, der er forberedt til fastgørelse på referenceakslen, og
en optager, der er forberedt til fastgørelse på forkantstykket (13) af rotorvingen
eller på et andet strukturelement af rotorvingen, og hvor optageren er forberedt
10 til at registrere en drejning af markørelementet i forhold til optageren for derved
at registrere en drejning af rotorvingen i forhold til referenceakslen på dette
sted.

6. Målesystem (10) ifølge et af de foregående krav,

15

kendetegnet ved, at

referenceakslen (12) er lejret på de flere drejesensorer (20) langs vingens
langsgående retning.

7. Fremgangsmåde til bestemmelse af en torsion af en rotorvinge, hvor

20

- en torsion af rotorvingen omkring en referenceaksel (12), der er anbragt i
rotorvingen i vingens langsgående retning, registreres,
- referenceakslen er lejret i rotorvingen således, at rotorvingen kan vrides frit
omkring referenceakslen (12), således at referenceakslen (12) ikke vrides ved
vridning af rotorvingen,

25

- en drejning registreres af mindst en drejesensor (20), der er anbragt på refe-
renceakslen, til registrering af en drejning af rotorvingen omkring reference-
akslen (12) i drejesensorens (20) område, og

- en drejevinkel, der beskriver drejningen af rotorvingen i forhold til reference-
akslen (12), eller en anden tilsvarende størrelse afgives ved hjælp af drejesen-
soren (20), og **kendetegnet ved, at**

30

- drejevinklen eller drejningen af rotorvingen registreres i flere positioner, der
er fordelt i vingens langsgående retning, og
- flere drejesensorer til registrering af en drejning af rotorvingen er anbragt i
flere positioner langs referenceakslen.

8. Fremgangsmåde ifølge krav 7,

kendetegnet ved, at

5 der anvendes et målesystem ifølge et af kravene 1 til 6, hvor især drejevinklen og/eller drejningen af rotorvingen registreres tidsmæssigt kontinuerligt.

9. Rotorvinge af et vindenergianlæg, og rotorvingen omfatter

- en rotorvingerod til fastgørelse af rotorvingen på et rotornav,

10 - en rotorvingespids, der er anbragt på en side af rotorvingen, der vender væk fra rotorvingeroden,

- en referenceaksel (12), der er anbragt i rotorvingen i vingens langsgående retning,

15 - mindst en lejrning af referenceakslen (12) til fri lejrning af referenceakslen (12) i rotorvingen, således at rotorvingen kan vrides frit omkring referenceakslen (12), således at referenceakslen (12) ikke vrides ved vridning af rotorvingen, og

20 - mindst en drejesensor (20), der er anbragt på referenceakslen, til registrering af en drejning af rotorvingen omkring referenceakslen (12) i drejesensorens (20) område, hvor drejesensoren (20) afgiver en drejevinkel, der beskriver drejningen af rotorvingen i forhold til referenceakslen (12), eller en anden tilsvarende størrelse, **kendetegnet ved, at**

- referenceakslen (12) er udformet som hul aksel, og

25 - flere drejesensorer til registrering af en drejning af rotorvingen er anbragt i flere positioner langs referenceakslen

10. Rotorvinge ifølge krav 9,

kendetegnet ved, at

30 der er tilvejebragt et forkantstykke (13), der forløber fra rotorvingeroden i retning mod rotorvingespidsen, og referenceakslen (12) og mindst et afsnit af drejesensoren er anbragt på forkantstykket (13).

11. Rotorvinge ifølge krav 9 eller 10,

kendetegnet ved, at

der anvendes et målesystem (10) ifølge et af kravene 1 til 6, og referenceakslen (12), den mindst ene lejrning af referenceakslen (12) og den mindst ene drejesensor (20) er elementer af dette målesystem.

5 **12.** Rotorvinge ifølge krav 11,

kendetegnet ved, at

rotorvingen i sin vingspids har en akseloptagelse (18) til drejefast lejrning af referenceakslen (12), og især referenceakslen (12) med et passtykke er fastklemmt drejestift i et strukturelement af rotorvingen, især i en indvendig kontur af et forkantstykke eller forkantstykket (13), eller

10

rotorvingen har en akseloptagelse (18) i vingeroden til drejefast lejrning af referenceakslen (12).

13. Fremgangsmåde til montering af et målesystem (10) ifølge et af kravene 1 til 6 i en rotorvinge af et vindenergianlæg, omfattende trinnene

15

- drejestiv fastgørelse af et passtykke på et vingspidsafsnit af referenceakslen (12),

- indskubning af referenceakslen (12) med passtykket foran i et monteringsrum i rotorvingens vingspids, langs et strukturelement, især et forkantstykke (13),

20

- påføring af lejringsmidlerne (22) på referenceakslen (12) og fastgørelse af lejringsmidlerne (22) langs strukturelementet eller forkantstykket (13),

- anbringelse af den mindst ene drejesensor (20) i referenceakslens (12) område i rotorvingen, hvor især

25

- nogle af lejringsmidlerne fastgøres i et ikke-betrædeligt område i nærheden af vingspidsen ved fastklemning på strukturelementet eller i forkantstykket, og

- nogle af lejringsmidlerne fastklæbes i et betrædeligt område på strukturelementet eller forkantstykket.

30

14. Fremgangsmåde til vedligeholdelse eller reparation af et målesystem, der er anbragt i en rotorvinge, til bestemmelse af en torsion af rotorvingen, og målesystemet omfatter

- en referenceaksel (12), der er anbragt i rotorvingen i vingens langsgående retning,

- mindst en lejrning af referenceakslen (12) til fri lejrning af referenceakslen (12) i rotorvingen, således at rotorvingen kan vrides frit omkring referenceakslen (12), således at referenceakslen (12) ikke vrides ved vridning af rotorvingen, og
- 5 - mindst en drejesensor (20), der er anbragt på referenceakslen, til registrering af en drejning af rotorvingen omkring referenceakslen (12) i drejesensorens (20) område, hvor drejesensoren (20) afgiver en drejevinkel, der beskriver drejningen af rotorvingen i forhold til referenceakslen (12), eller en anden tilsvarende størrelse, omfattende trinnene:
- 10 - udtagning af referenceakslen eller en del deraf fra mindst en af lejringerne,
- afmontering af denne mindst ene lejrning og/eller den mindst ene drejesensor,
- kontrol af den afmonterede lejrning eller den afmonterede drejesensor og
- genindsætning af lejrningen eller drejesensoren eller en tilsvarende reservedel,
- 15 - genindsætning af referenceakslen eller den udtagede del deraf, hvor der som målesystem anvendes et målesystem ifølge et af kravene 1 til 6.

- 15.** Vindenergianlæg omfattende mindst en rotorvinge ifølge et af kravene 9 til 12 og desuden eller alternativt et målesystem (10) ifølge et af kravene 1 til 6.
- 20

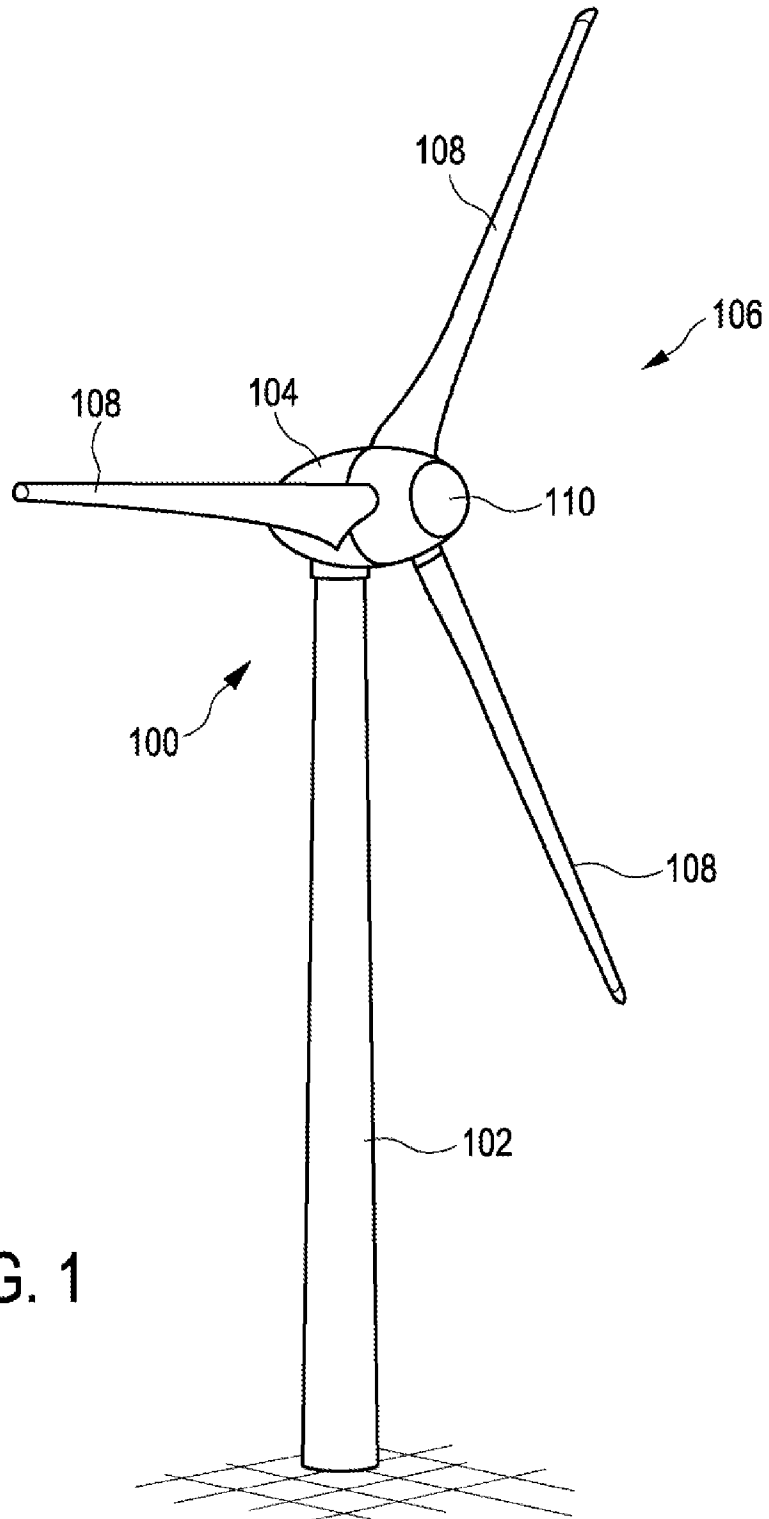

FIG. 1

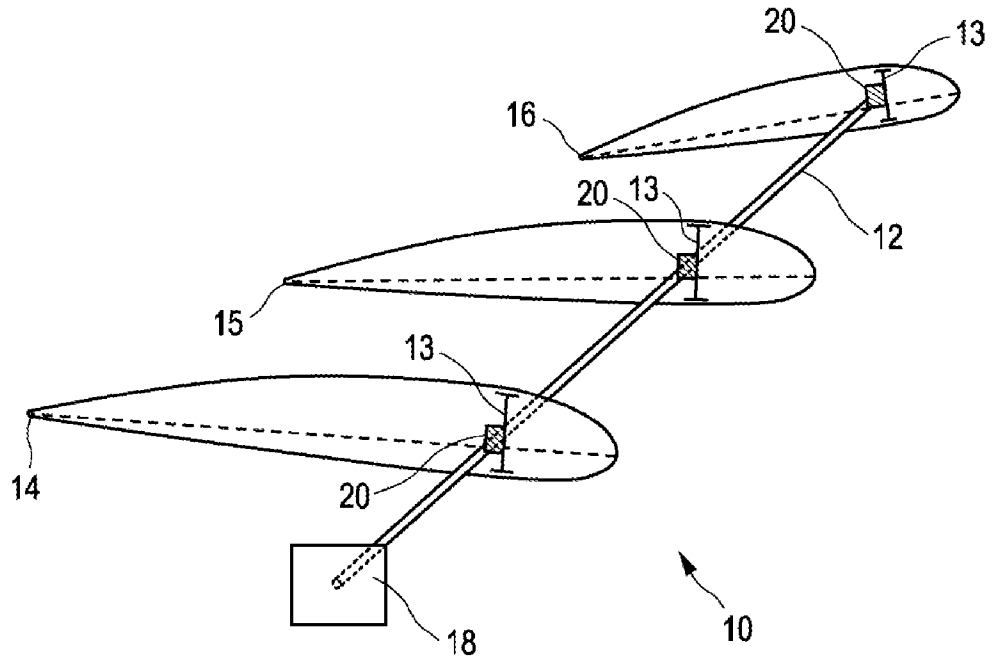

FIG. 2

FIG. 3

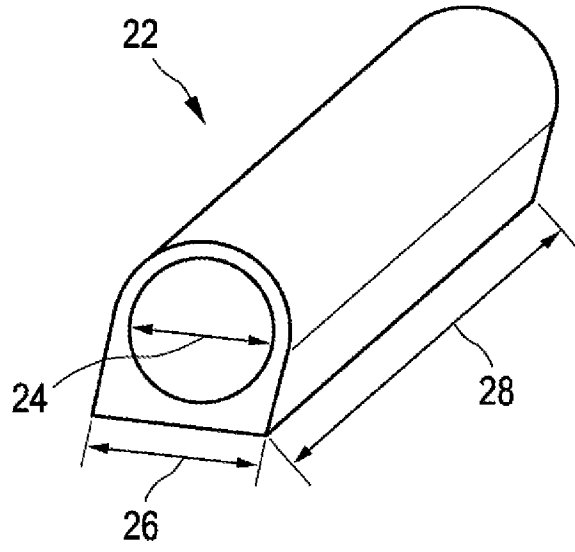
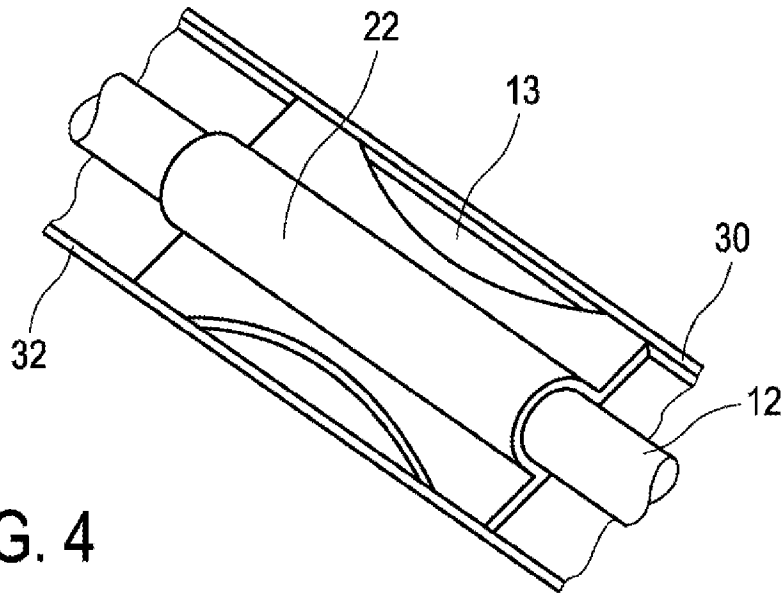
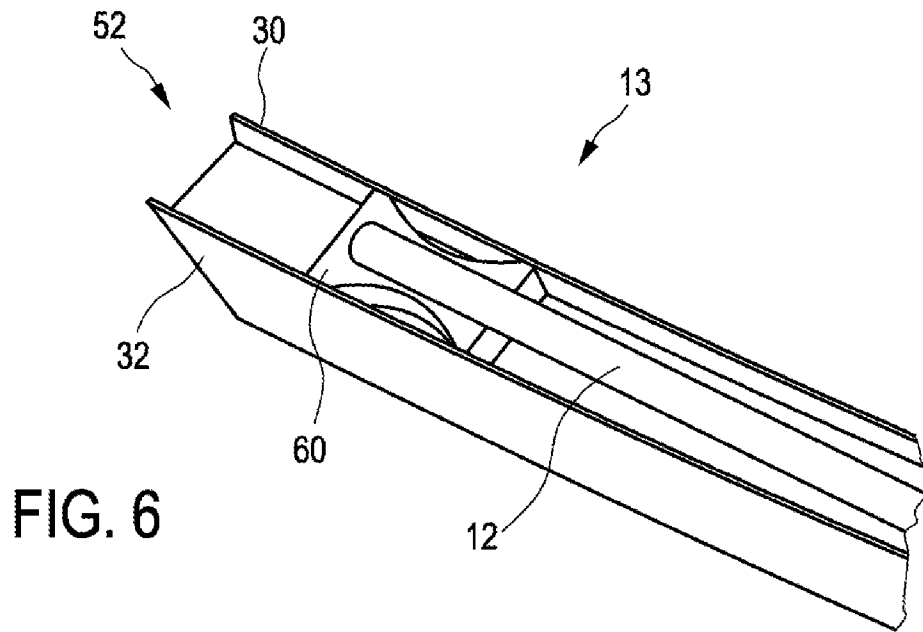
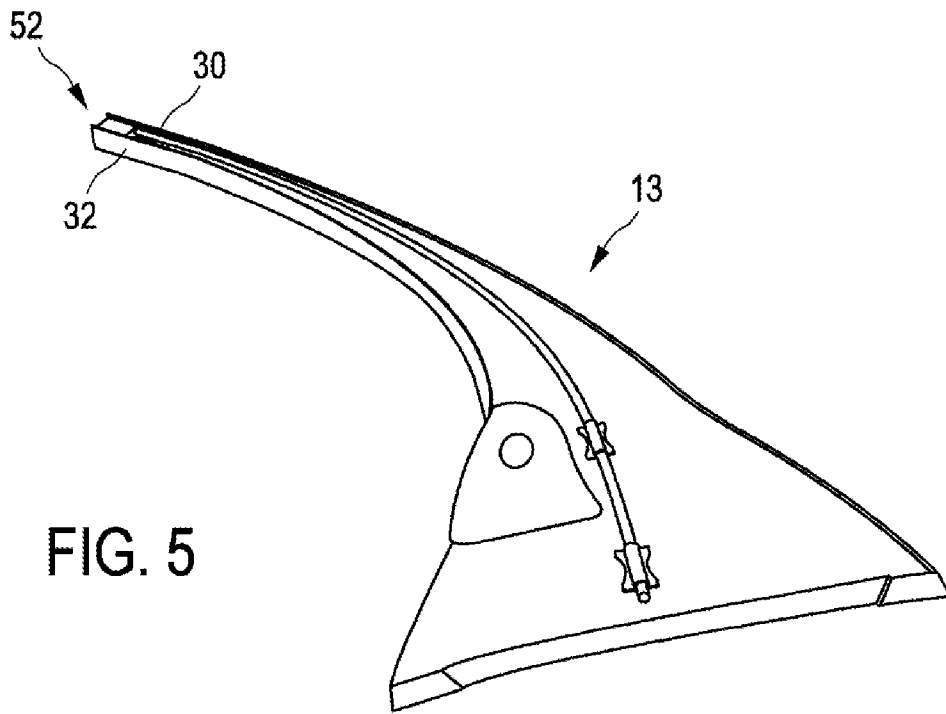

FIG. 4





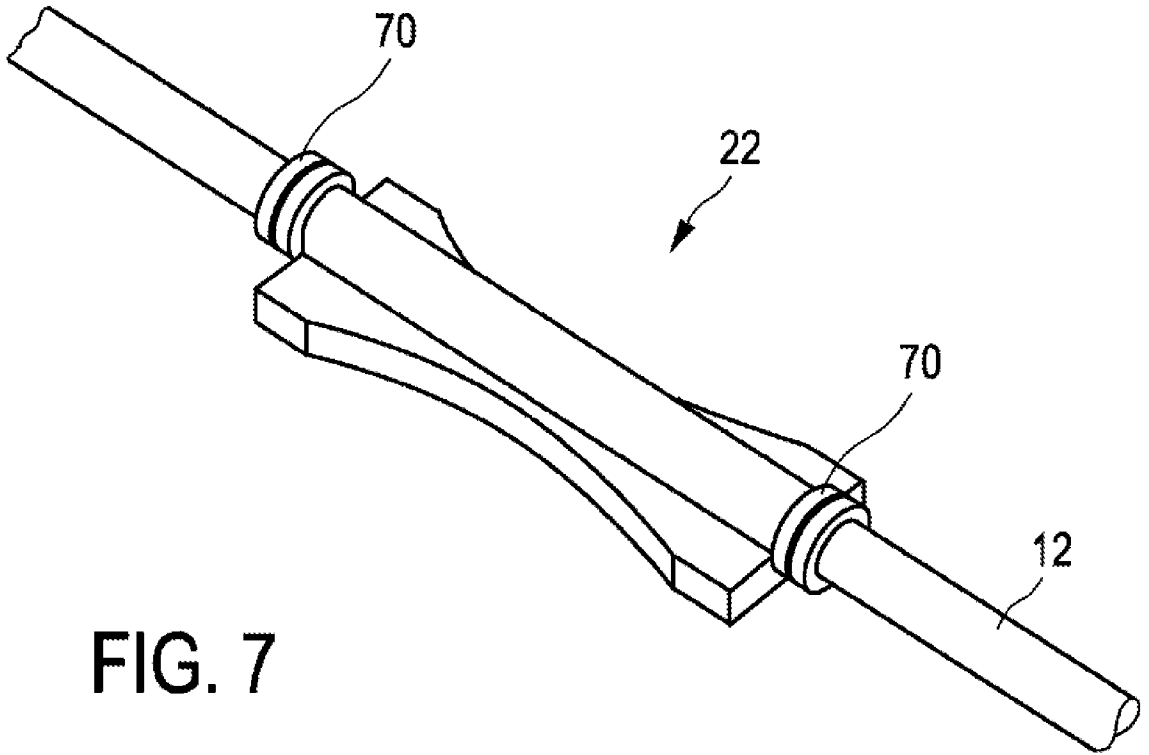

FIG. 7