

(No Model.)

3 Sheets—Sheet 1.

J. THOMSON. DISK WATER METER.

No. 485,437.

Patented Nov. 1, 1892.

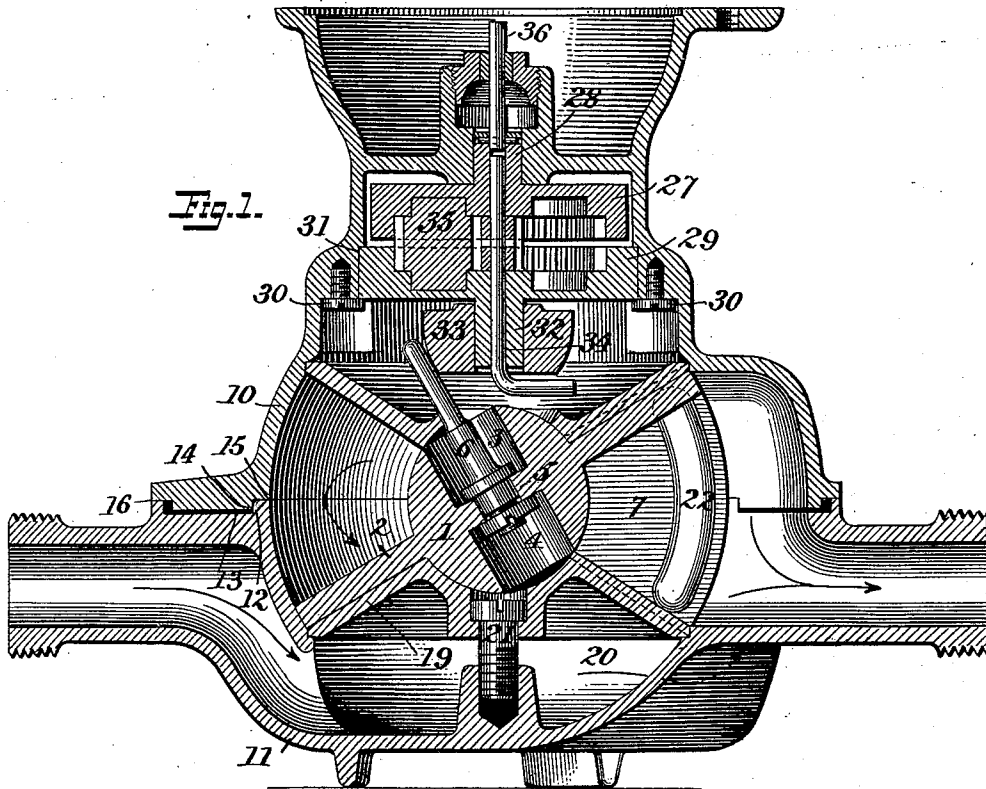

Fig. 1.

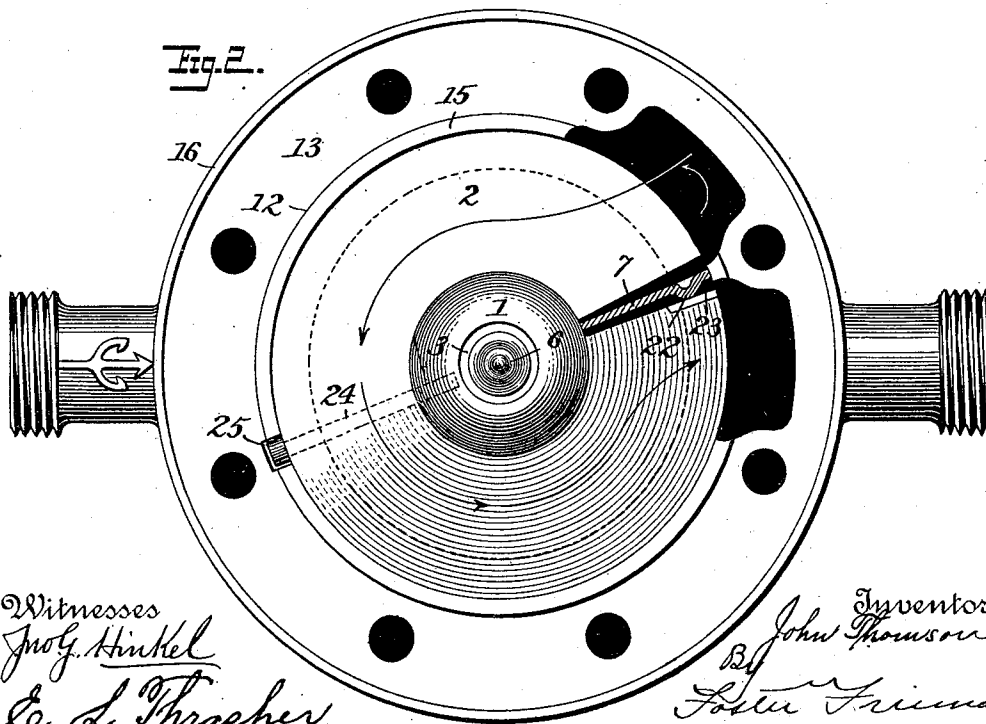

Fig. 2.

Witnesses
John Hinkel
E. L. Thrasher

Inventor
John Thomson
 By
Foster Freeman
 Attorneys

(No Model.)

3 Sheets—Sheet 2.

J. THOMSON. DISK WATER METER.

No. 485,437.

Patented Nov. 1, 1892.

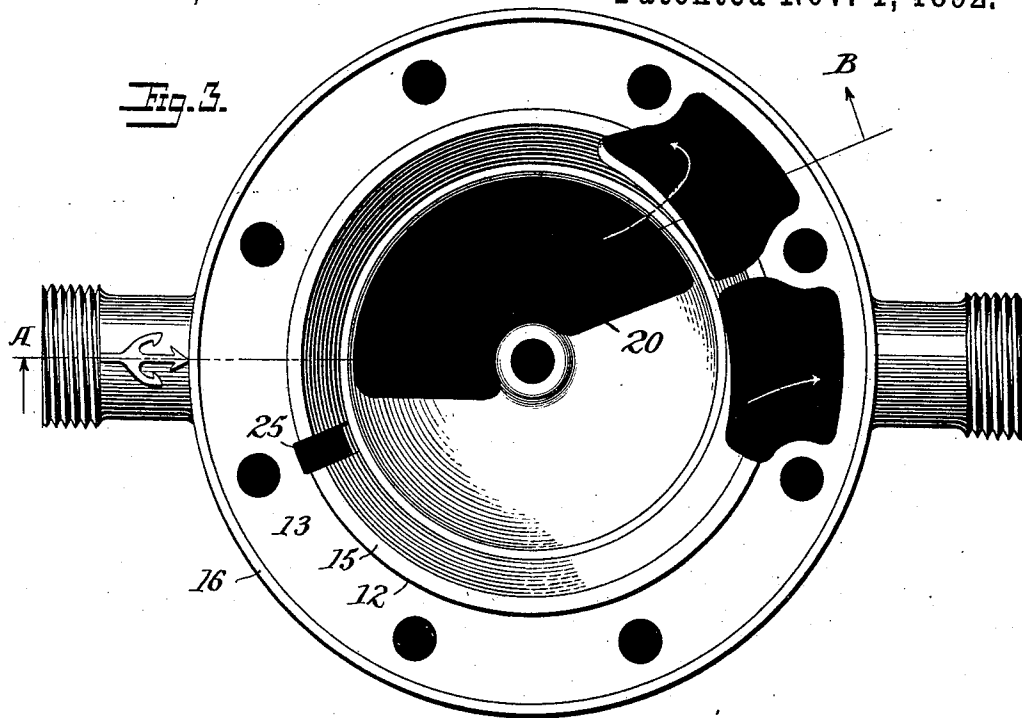

Fig. 3.

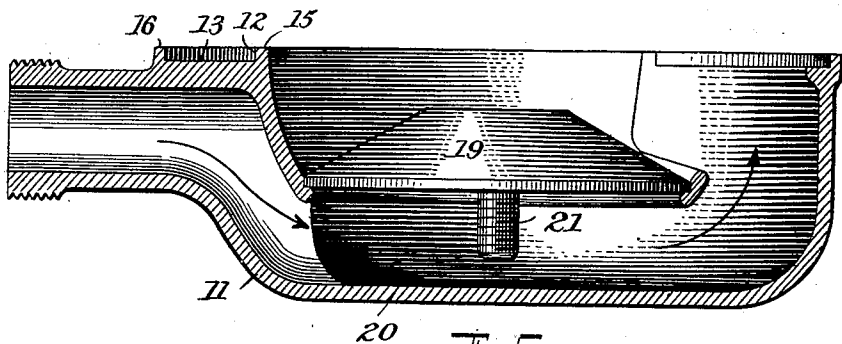
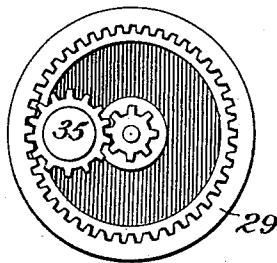

Fig. 4.



Witnesses
Judy Hinkel
E. L. Thrasher.

Inventor
John Thomson
 By *Foster Freeman*
 Attorneys

J. THOMSON.
DISK WATER METER.

No. 485,437.

Patented Nov. 1, 1892.

Fig. 6.

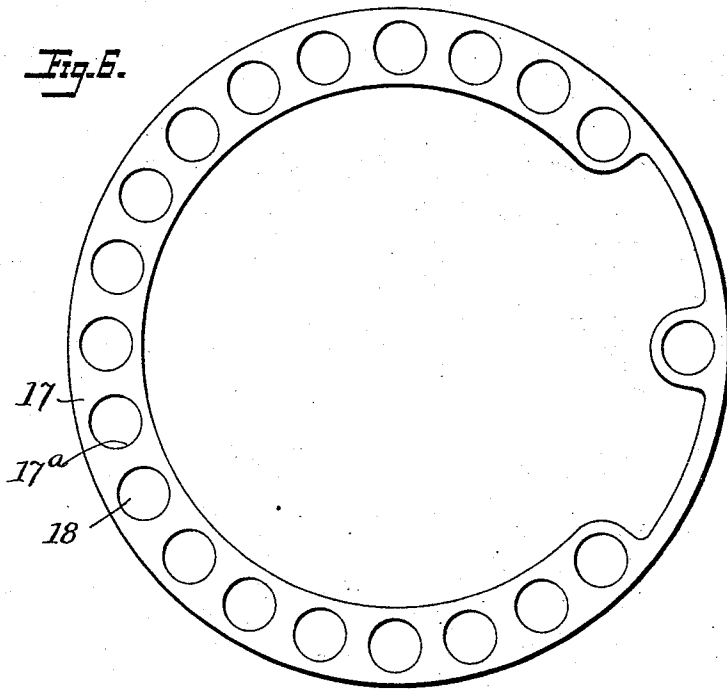

Fig. 8.

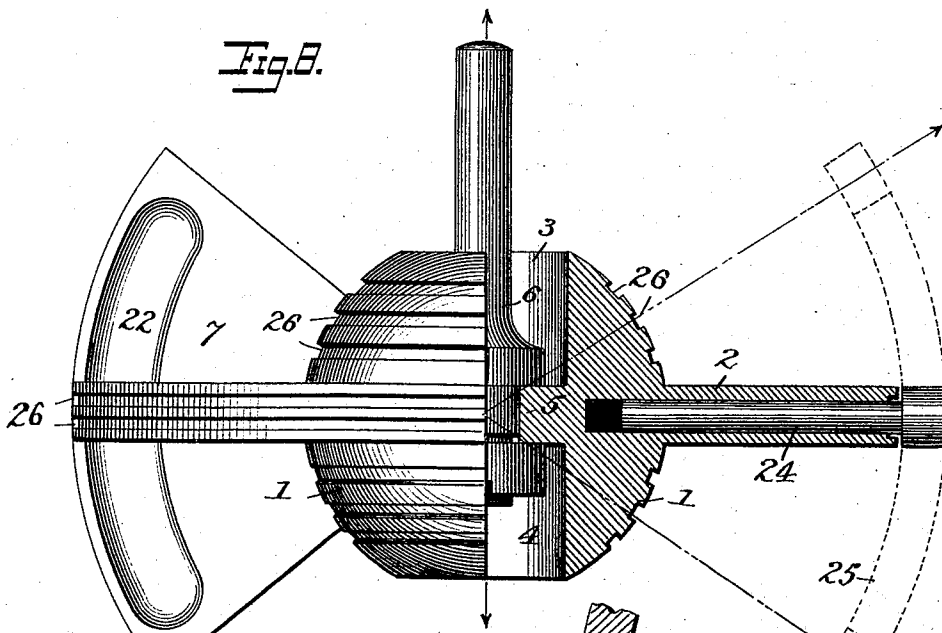
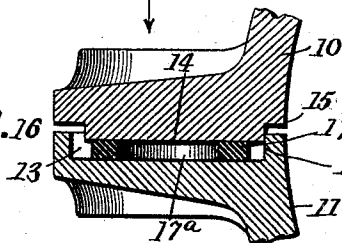

Fig. 7.



Witnesses
Prof. Hinkel
E. L. Thrasher

Inventor
John Thomson
 By *Frederic F. ...*
 Attorneys

UNITED STATES PATENT OFFICE.

JOHN THOMSON, OF BROOKLYN, NEW YORK, ASSIGNOR TO THE THOMSON HYDRAULIC COMPANY, OF NEWARK, NEW JERSEY.

DISK WATER-METER.

SPECIFICATION forming part of Letters Patent No. 485,437, dated November 1, 1892.

Application filed May 31, 1892. Serial No. 434,999. (No model.)

To all whom it may concern:

Be it known that I, JOHN THOMSON, a citizen of the United States, residing at Brooklyn, Kings county, State of New York, have invented certain new and useful Improvements in Disk Water-Meters, of which the following is a specification.

This invention relates to disk water-meters; and it consists in detail improvements upon the invention shown and described in my application of February 18, 1892, Serial No. 422,015. Therefore the following description will refer specifically to the present modifications.

In the drawings, Figure 1 is a vertical central section of a meter showing my improvements. Fig. 2 is a top plan view of the lower casing and the disk, the diaphragm shown in section and the disk tilted up to lie in a horizontal plane for convenience and clearness of illustration. Fig. 3 is a detail top plan view of the lower casing. Fig. 4 is a detail transverse sectional view on the lines A and B of Fig. 3. Fig. 5 is a detail plan view of the internal speed-reducing gear-train. Fig. 6 is a detail view of the gasket. Fig. 7 is an enlarged detached sectional detail through the flanges and the gasket. Fig. 8 is a part elevation and section of the diaphragm of the ball and the disk.

The first improvement relates to the flanges and the gasket. In the said previous application the upper and lower casings 10 11, which form the spherical contour of the disk-chamber, are shown as being guided together centrally by the periphery of the flange of the upper casing entering a bearing formed in the outer diameter of the flange of the lower casing. When constructed in this manner it can only be inferred that the face contact-surfaces of the flanges are together, and as it is often desirable to have ocular demonstration that the said faces of the flanges are in absolute contact with each other I have arranged the flanges in the manner shown in the accompanying drawings, wherein it will be seen that the casings are guided together by the internal wall 12 of the recess 13 of one casing, to which the inner cylindrical bearing 14 of the other casing is adapted. Thus the flanges will be drawn together by the flange-

bolts against the resistance of the gasket until the inner face contact-surfaces 15 and the outer face contact-surfaces 16 impinge upon each other. Hence as the edges of the outer surfaces are exposed there can be no question as to the proper relative adjustment of the casings. In this connection I have also found it desirable to provide the molded gum-rubber gasket 17 with a plurality of holes or indentations, as 17^a, disposed between the bolt-holes, as 18, whereby when the flanges are drawn together the rubber will thus be free to flow within the recess provided therefor, not only externally, but internally, thus equalizing the resistance between the flange-bolts and also reducing the quantity of rubber required.

The second improvement is in utilizing the lower frustum 19 to form a separately-receiving channel or chamber 20 in the lower disk-chamber casing instead of providing a cored channel, as shown in the said application, Serial No. 422,015, the function of this receiving-channel being to conduct water to the inlet-port. The advantage of this is that by simply securing the frustum to its bearing in the casing, as by means of the screw 21, the casting of the lower casing is simplified and less material is required.

The third improvement relates to the diaphragm 7, and consists in forming it with a rib, as 22, upon one of its face-surfaces to serve as a bearing for the edge 23 of the disk. I prefer to form this rib by stamping or embossing it out of the body of the diaphragm. The advantage of this construction is that free displacement-spaces are provided at and around the edges of the disk without removing material from the disk.

The fourth improvement relates to means for controlling the thrust of the disk, which consists of the freely-mounted bearing-pin 24, preferably situated diametrically opposite to the bearing edge of the disk and adapted to operate in a vertical slot 25, formed in the walls of the casings. In this wise the thrust of the disk due to the flow of the water may be resisted by two points of control. The bearing-pin may have an enlarged head, as shown, or be provided with a roll to reduce the friction. The said bearing-pin may also

be employed separately, no contact being made upon the diaphragm.

The fifth improvement consists in the design of the ball 1 and disk 2, whereby they
 5 may be made of hard rubber molded together as one part with sufficient accuracy not to require additional finishing. Attempts in this direction heretofore have been unsuccessful, in that the greater thickness or mass of the ball
 10 as compared to the distribution of material in the disk has resulted in unequal and variable shrinkages. This I overcome by the simple expedient of providing the die with an inwardly-projecting metal core central to
 15 the ball, vertical to the plane of the disk, so that the heat during the vulcanizing process is conducted to the ball both from the exterior and from the interior thereof, and owing to the uniformity of heat conduction thus effected this important member of this meter
 20 may not only be made very accurately, but, what is even of greater importance, with the utmost uniformity. By not passing the metal core entirely through the ball, but projecting it inwardly from either side, the ball
 25 is thus produced with two cylindrical openings 3 4, leaving a partition 5 in its center, which provides a convenient and rigid base for the attachment of the disk-spindle 6, as
 30 shown.

The sixth improvement also relates to the ball and disk, and consists in forming a plurality of grooves, as 26, in the surface of the ball and the peripheral surface of the disk,
 35 the object of which is to provide clearance-spaces wherein particles of sand or other foreign material liable to be forced between the bearing-surfaces may enter these spaces and eventually work their way out instead of being retained to wear and cut the bearings.
 40

The seventh improvement relates to the manner of applying the internal reducing gear-train to the meter. The type of gear-train here employed is fully described and
 45 shown in my application of February 2, 1892, Serial No. 420,046. The present improvement consists in applying the free differential gear-wheel 27, having a journal 28, to a bearing formed in the main casing and in
 50 then securing the fixed differential gear 29, as by means of the screws 30, directly to the the recess 31, also formed within the main

casing. In this wise no additional mounting whatever is required, the lower fixed gear serving to provide the journal 32 for the controlling-block 33, as well as for the pivot 34
 55 of the primary driving-pinions 35, while free differential gear is connected to the stuffing-box spindle 36. The advantage of this arrangement and disposal is a considerable
 60 reduction in the number of parts, in the material, and in the operations heretofore required. The assemblage is also very simple, the gears being virtually dropped into position.

I claim—

1. The combination, with the disk suitably mounted, of the diaphragm having a raised bearing-rib, substantially as described.

2. The combination, with the disk-chamber casing having a slot 25 formed in the spherical wall thereof, of a disk mounted in the casing and provided with a bearing-pin acting within the slot, substantially as described.

3. In a disk water-meter, a disk provided with a ball having cylindrical openings on opposite sides of the ball and a rigid central partition between the openings and a disk-spindle rigidly mounted in said partition, substantially as described.

4. In a disk water-meter, a disk having grooves in its peripheral surface, as and for the purpose set forth.

5. In a disk water-meter, a disk provided with a ball having grooves in its surface, substantially as described.

6. In a disk water-meter, the combination, with the main upper recessed casing forming a portion of the spherical contour of the disk-chamber, of the free differential gear 27, provided with a journal 28, mounted in a bearing in the main casing and connected to the stuffing-box spindle, and the fixed differential gear 29, fitting the recess in said casing and secured thereto and provided with a journal 32, for the controlling-block 33 and for the pivot 34 of the primary driving-pinion 35, substantially as described.

In testimony whereof I have signed my name to this specification in the presence of two subscribing witnesses.

JOHN THOMSON.

Witnesses:

ROBERT S. CHAPPELL,

JOHN MCKINNON.